

# ASSEMBLY INSTRUCTIONS

---

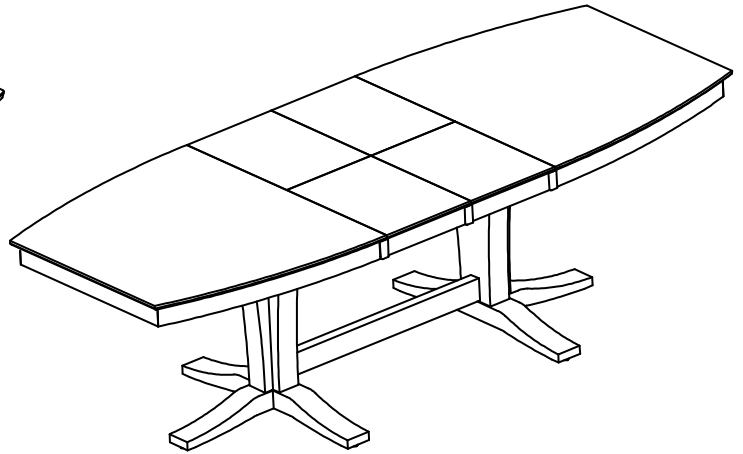

**T-4096XXB AND T-4096XXT**

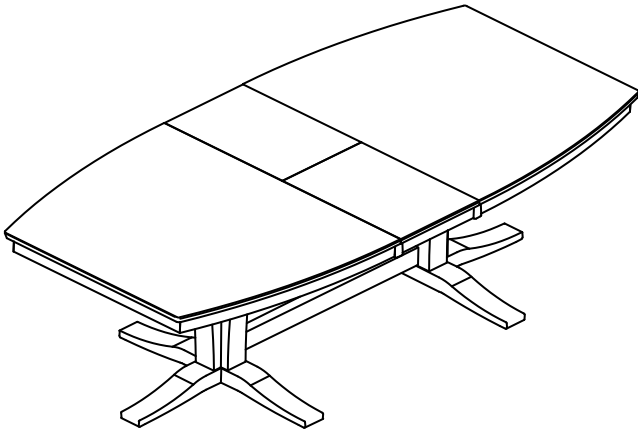
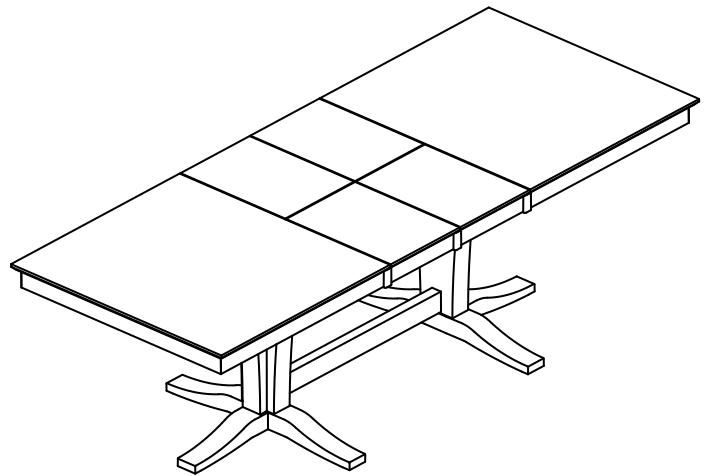
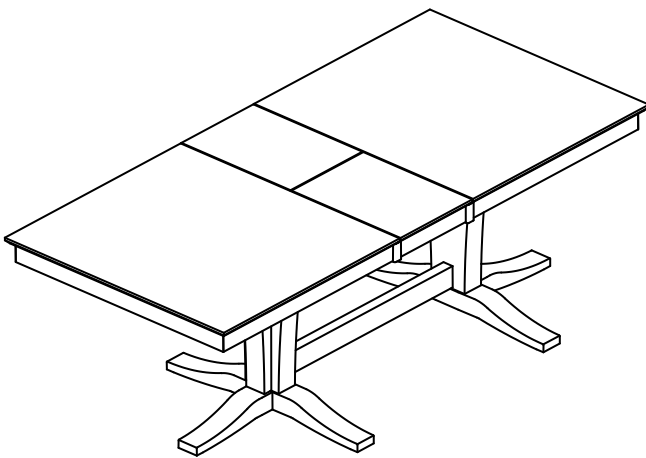

**T-4096XXB AND T-3896XXT**

---

Description	: MILANO TABLE BASE
Item No.	: T-4096XXB AND T-4096XXT OR T-3896XXT (PACKED IN SEPARATE BOX)

**ITEM NO.: T-4096XXB AND T-4096XXT OR T-3896XXT**  
(PACKED IN SEPARATE BOX)  
**REVISED MAY 08, 2019**

**Printed in Vietnam**

## BEFORE ASSEMBLY

Thank you for purchasing this quality product. This product has been designed for easy assembly and constructed for durability. All parts were checked prior to packaging to insure quality. Prior to beginning assembly, however, make sure all parts and hardware are included and free of obvious defect. If a part is missing or defective, please contact the store where purchased. If hardware is missing, or you need help with assembly, please call toll free 888-944-8396.

### IMPORTANT NOTE:

- Place all wooden parts on a clean and smooth surface such as a rug or carpet to avoid the parts from being scratched.
- Remove all wrapping material, including staples & packing straps before you start to assemble.
- DO NOT tighten all screws and bolts until completely assembled.
- Keep all hardware parts out of reach of children.

### WARNING:

Long exposure to rubber or soft plastic may cause a chemical reaction and damage the finish of your table. Protect the surface of the table with cloth if you are using any product with rubber feet or base.



ITEM NO.: T-4096XXB AND T-4096XXT OR T-3896XXT  
(PACKED IN SEPARATE BOX)

Printed in Vietnam

REVISED MAY 08, 2019

## PART LIST T-4096XXT

When unpacking, please be careful not to discard any parts with the packaging. Before continuing, please make sure you have the following parts:

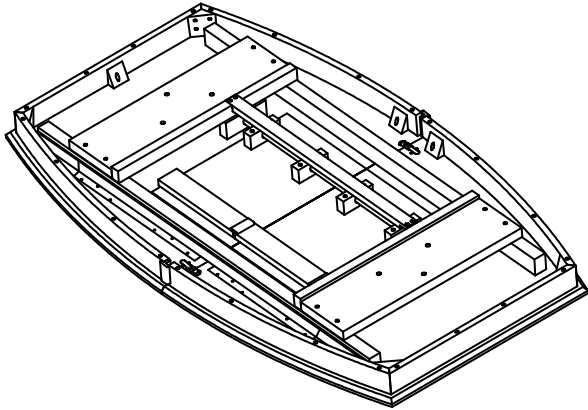
NO	Description	Qty	Sketch
A	Top	1	

## PART LIST T-3896XXT

When unpacking, please be careful not to discard any parts with the packaging. Before continuing, please make sure you have the following parts:

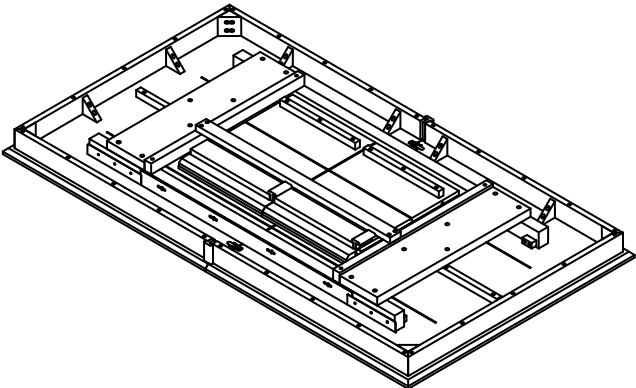
NO	Description	Qty	Sketch
A	Top	1	

**ITEM NO.: T-4096XXB AND T-4096XXT OR T-3896XXT**



(PACKED IN SEPARATE BOX)

**REVISED MAY 08, 2019**

**Printed in Vietnam**



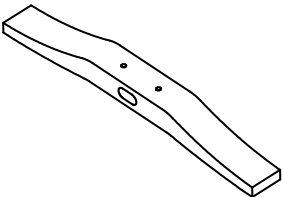
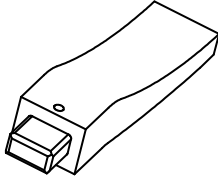

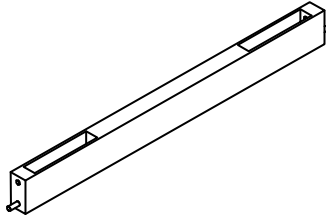
## PART LIST T-4096XXB

When unpacking, please be careful not to discard any parts with the packaging. Before continuing, please make sure you have the following parts:

NO	Description	Qty	Sketch	NO	Description	Qty	Sketch
B	Long leg	2		C	Short leg	2	
D	Pedestal column	2		E	Crossbar	1	

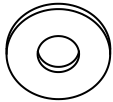
## HARDWARE LIST

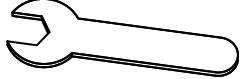
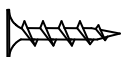
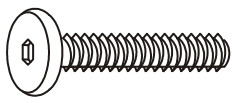
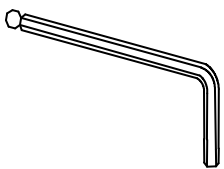
When unpacking, please be careful not to discard any parts with the packaging. Before continuing, please make sure you have all of the following hardware:

NO	Description	Qty	Sketch	NO	Description	Qty	Sketch
1	Hexagon Nut (M8 x 13mm)	12		2	Flat Washer (2 x $\Phi$ 8.5 x 19mm)	12	
3	Lock Washer ( $\Phi$ 8.5 x 11mm)	12		4	Wrench (M13mm)	1	
5	Wood Screw (M4 x 30mm)	4		6	Bolt (M8 x 70mm)	2	
7	Allen key (M4 x 30mm x 110mm)	1		8	U-washer (M8)	2	

**NOTE: HARDWARE IS PACKED IN CARTON T-4096XXB.**

**ITEM NO.: T-4096XXB AND T-4096XXT OR T-3896XXT**  
(PACKED IN SEPARATE BOX)

**Printed in Vietnam**

**REVISED MAY 08, 2019**

## STEP 1

Attach crossbar (E) to pedestal columns (D) with bolts (6) and u-washers (8) as shown below. Tighten with Allen key (7).

Insert short legs (C) into long legs (B) and attach with screws (5) as shown below. Tighten with a screwdriver.

Attach legs (B) to pedestal columns (D) with nuts (1), and washers (2) and (3) as shown below. Tighten with the wrench (4).

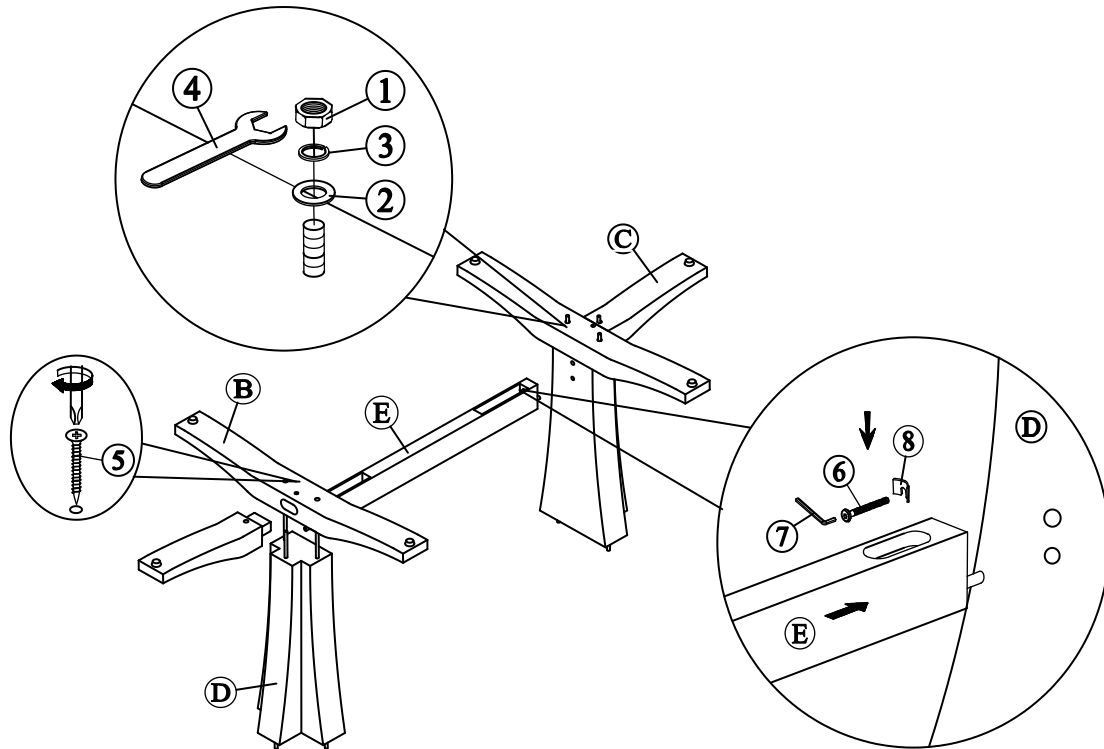

## STEP 2

Use Allen key (7) to loosen bolts and washers and take out the mounting plates underneath the table top as shown below.

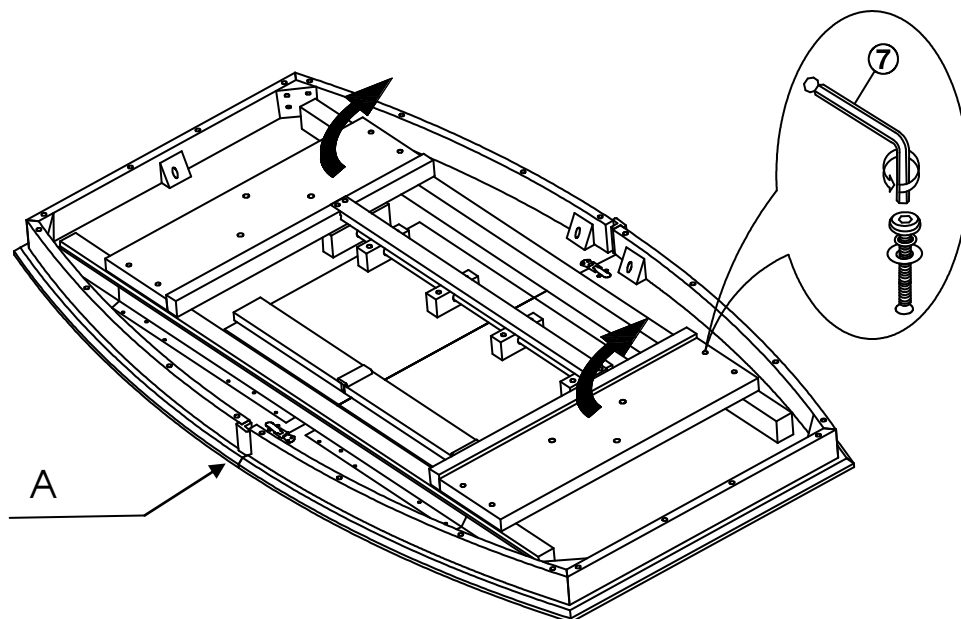

ITEM NO.: T-4096XXB AND T-4096XXT OR T-3896XXT

(PACKED IN SEPARATE BOX)

REVISED MAY 08, 2019

Printed in Vietnam

## STEP 3

Attach mounting plates on top of the pedestals (D) with nuts (1), and washers (2) and (3) as shown below. Tighten with the wrench (4).

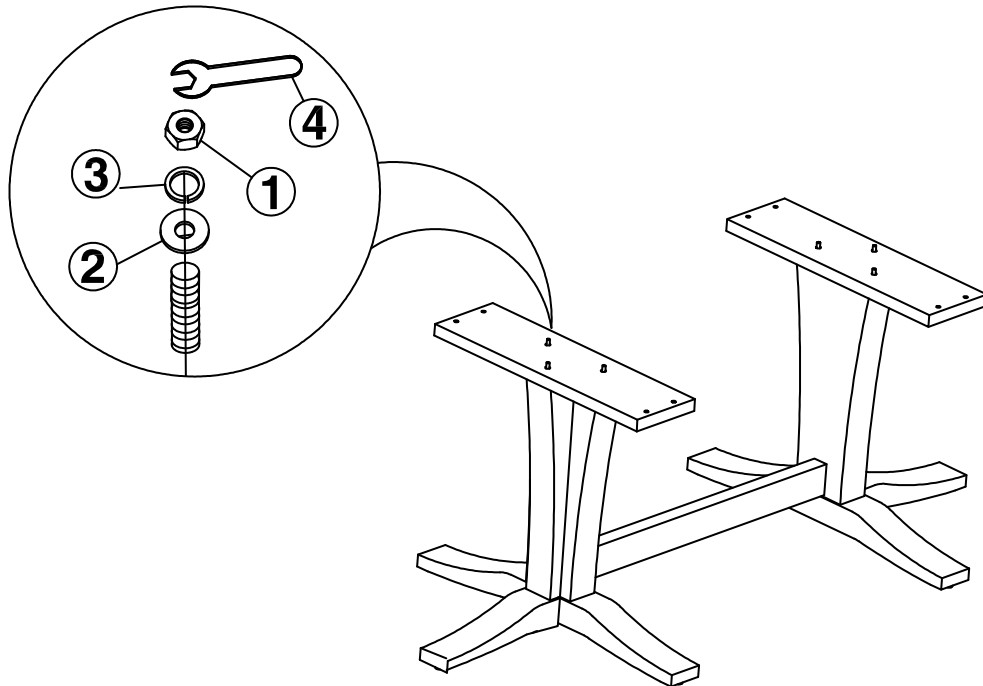

## STEP 4

Carefully place the base on the bottom side of the top (A).

Attach mounting plates to top (A) with bolts and washers (from step 2) as shown below. Tighten with Allen key (7).

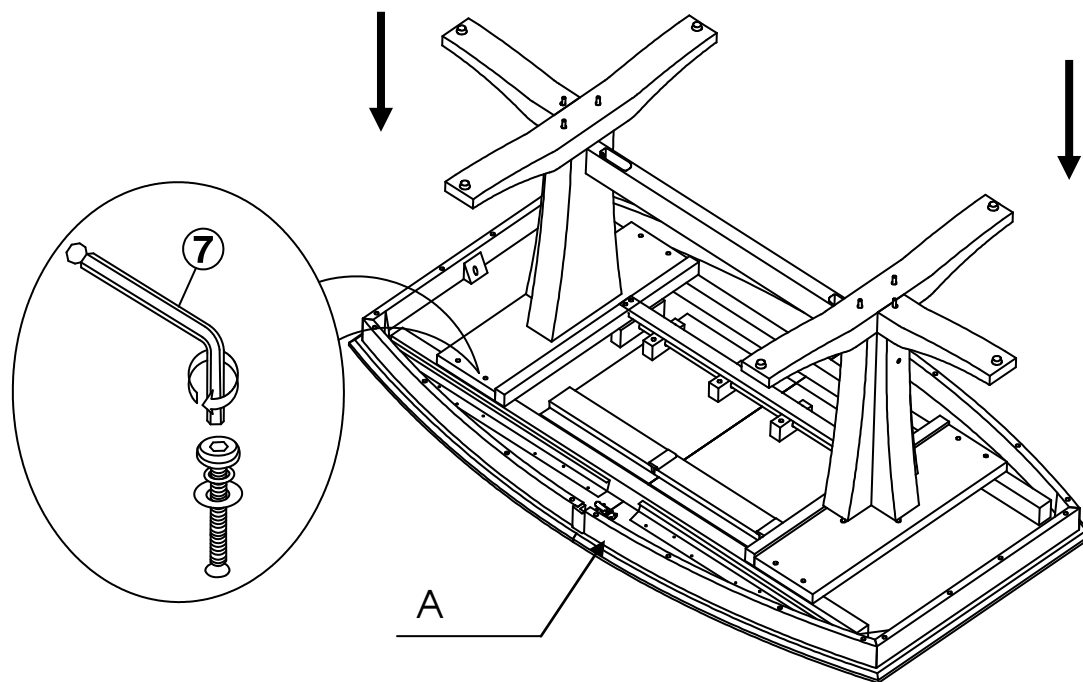

ITEM NO.: T-4096XXB AND T-4096XXT OR T-3896XXT

(PACKED IN SEPARATE BOX)

REVISED MAY 08, 2019

Printed in Vietnam

## STEP 5

Unlock the table top from both sides underneath the top as shown below. Pull the two parts of the table top apart.

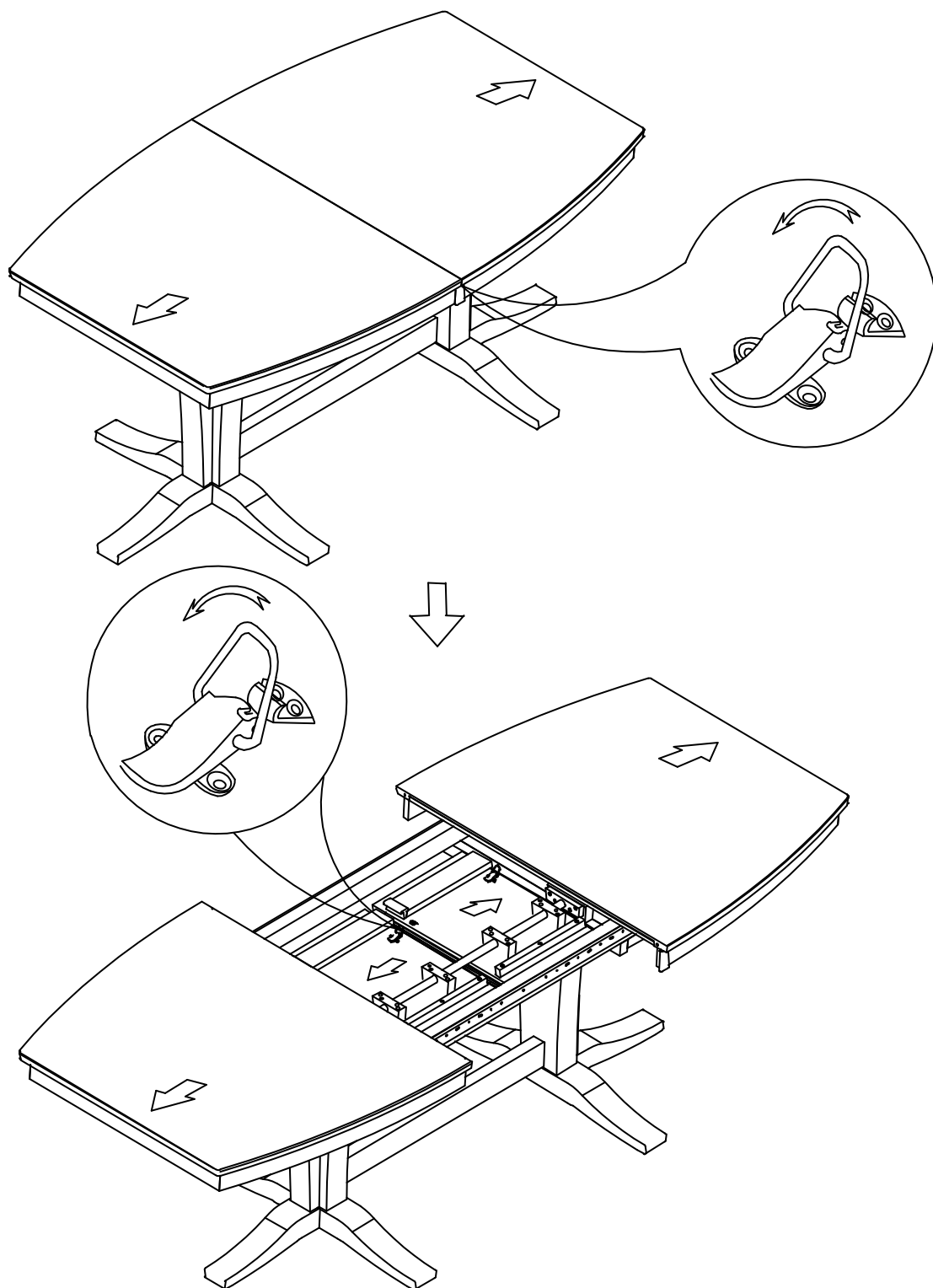

ITEM NO.: T-4096XXB AND T-4096XXT OR T-3896XXT

(PACKED IN SEPARATE BOX)

REVISED MAY 08, 2019

Printed in Vietnam

## STEP 6

Place the leaves in the center of the open table top, as shown below.

**Note:** The metal swivel bar bracket is very flexible and a slight twist of one half of the leaf can get the leaf into alignment. With one of these tops opened and in the topside up position and can be attached to the base to accomplish this too.

Have the top fully extended first, pull the leaf operation out, and with one leaf end down and other in the upward position, grasp the sides of the leaf w/ two hands and twist slightly (the metal bracket is flexible) so to shift the alignment of the leaf and then lower it into place being careful not to let the metal pins hit the edges of top or the leaf apron end, but repeat if necessary so to get the pins to align. We use the flexible metal bar for this purpose, as a hardened metal would snap during transport or damage the under structure.

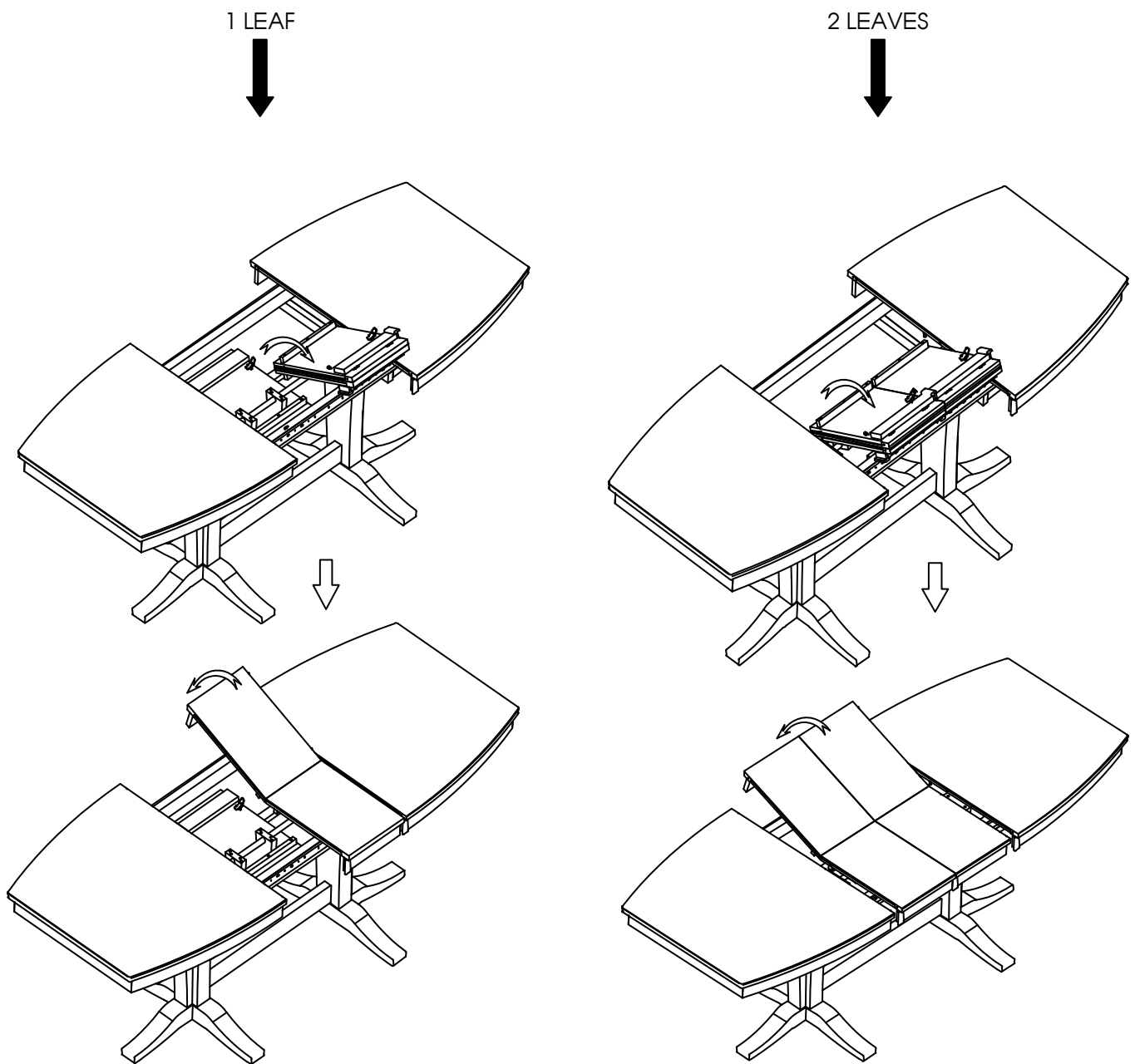

ITEM NO.: T-4096XXB AND T-4096XXT OR T-3896XXT

(PACKED IN SEPARATE BOX)

REVISED MAY 08, 2019

Printed in Vietnam

## STEP 7

Push the table top closed. Lock the mechanism underneath two sides of the table top as shown below.

1 LEAF

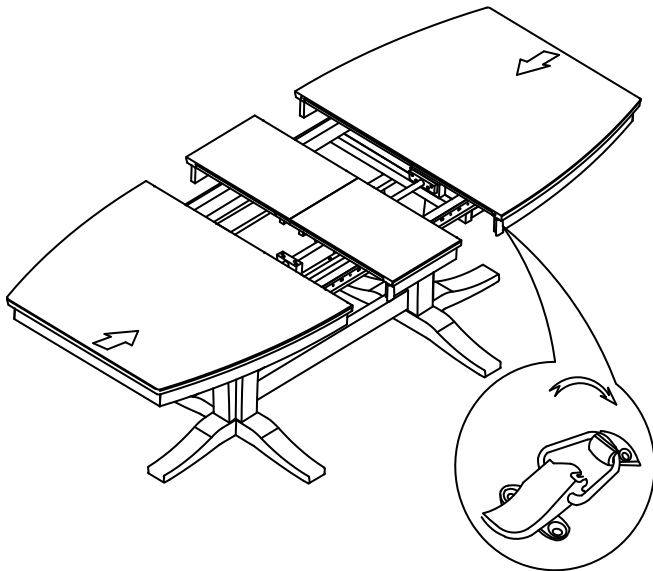

2 LEAVES

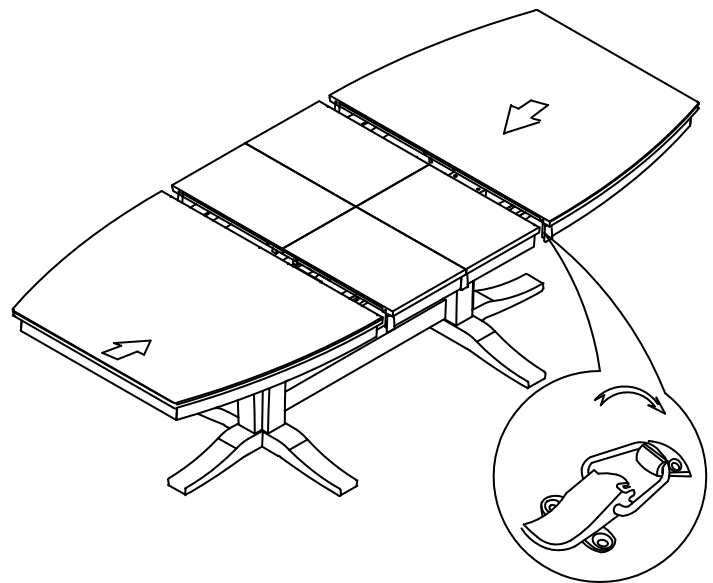

ITEM NO.: T-4096XXB AND T-4096XXT OR T-3896XXT

(PACKED IN SEPARATE BOX)

REVISED MAY 08, 2019

Printed in Vietnam