

Padded Beds

This warranty is between _____ the original purchaser and is valid only when accompanied by the original purchaser's sales receipt showing original date of purchase and location of purchase. Replacements under this warranty revert to the date of original purchase for future warranty. Maintain this warranty document and your sales receipt in a safe place.

_____ or its authorized dealer can accept or reject warranty claims based on its findings. This warranty applies in normal residential use only. Normal residential use only is described as using the product on a level surface with all legs touching the floor with an equal distribution of weight. The product is to be used with standard mattresses only. This warranty is invalid if the product is not used for its intended purpose. Boyd Sleep can make substitutions as required of materials, components, and sub-components of comparable value and utility. Boyd Sleep reserves the right to refuse service and invalidate the warranty when, upon inspection, the product failure is caused by factors other than defective workmanship or materials.

Manufacturing defects include when the product has become defective where it will not support the mattress properly.

Sales and use taxes, plus shipping and handling charges are the responsibility of the consumer. Consumer is required to deliver damaged product to the authorized dealer.

Certain items are not covered by this warranty. These include, but are not limited to the following:

1. Components subjected to abuse including abuse intended to simulate failure.
2. Damages caused by shipper, dealer, or installation crew such as scratches, dents, fabric tears etc.
3. Any part which merely exhibits normal wear yet functions essentially as new.
4. Boyd Sleep disclaims liability for any aspect of installation and any inconvenience caused by a defective part of a component.
5. Tears, punctures, dents, or any damage caused by improper installation.
6. Items sold "as is" and Floor Model Units.
7. Boyd Sleep warrants only the products listed at the top of this page. This warranty does not extend to any mattress that may be placed on the listed products.
8. Weight Capacity – King, California King, Queen, Double size – 700 Lbs. Twin size – 400 Lbs.

To make a claim, return the defective part along with your original sales receipt to an authorized Boyd Sleep dealer. If there is not a dealer in your area, send a copy of the original sales receipt, the defective product along with a brief description of the problem to:

All items must be sent freight prepaid.

Replacement will be made at the company's option. This is the entire exclusive express limited warranty. The manufacturer neither makes nor is responsible for any other warranties, either expressed or implied, including those of retailing dealers. **Any and all liability for breach of warranty, as well as damages for incidental or consequential losses is expressly denied.**

Platform Bed
Assembly Instruction
Contains One Bed and Hardware

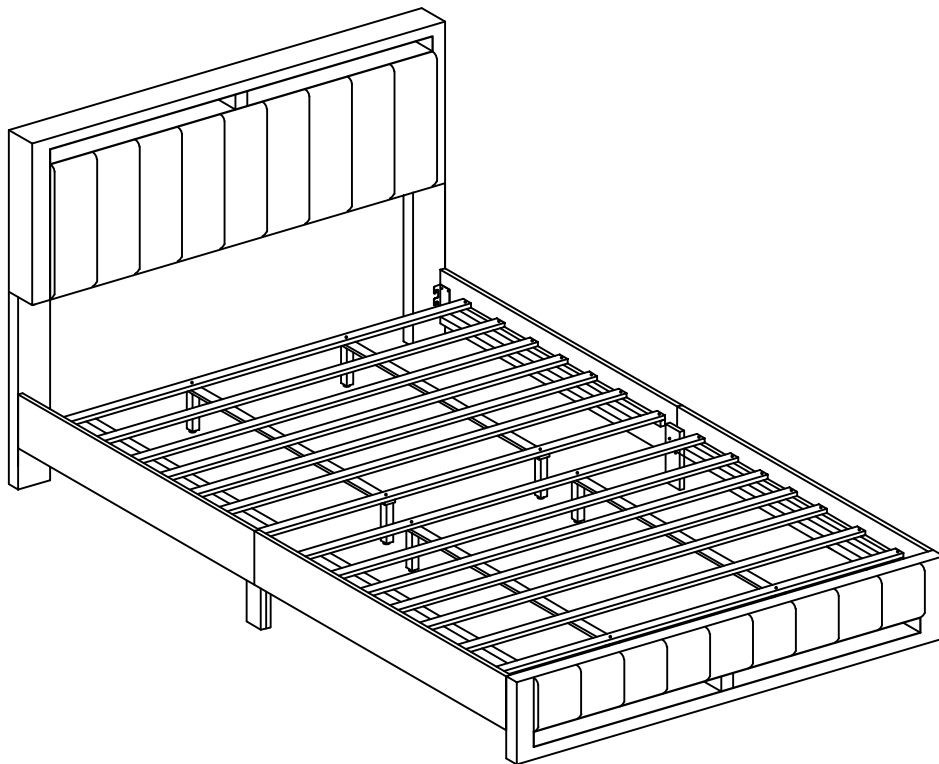

IMPORTANT NOTE:

Carefully remove all the parts from the box. Arrange on a flat surface and verify you have all of the following parts and hardware

TOOLS REQUIRED:
Phillips Screwdriver

PARTS LIST

A. Headboard (1 pc)

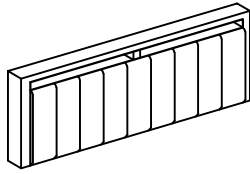

B. Footboard (1 pc)

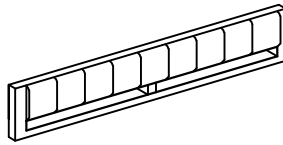

C. Side Rail (4 pcs)

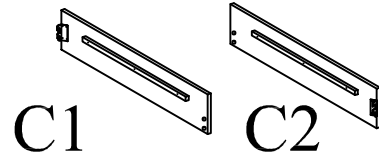

D. Headboard Legs (2 pcs)

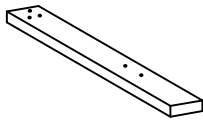

E. Center Rail (4 pcs)

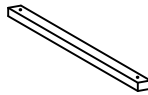

F. Side Rail Leg (2 pcs)

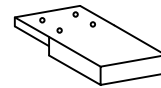

G. Wood Slat System (2 pcs)

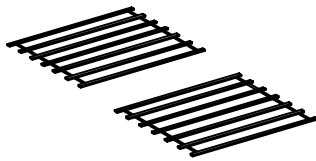

H. Center Leg (8 pcs)

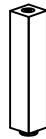

HARDWARE LIST

I. 20mm Bolt (8 pcs)

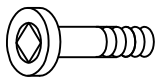

J. 30mm Bolt (8 pcs)

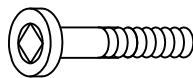

K. 60mm Bolt (8 pcs)

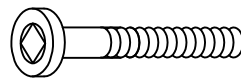

L. 50mm Bolt (6 pcs)

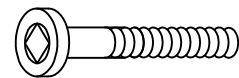

M. Large Hex Key (1 pc)

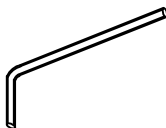

N. Small Hex Key (1 pc)

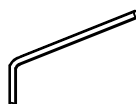

O. Spring Washer (6 pcs)



P. Flat Washer (8 pcs)

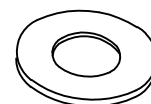

Q. 32mm Screw (28 pcs)

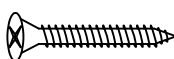

R. Adjuster (8 pcs)



ASSEMBLY INSTRUCTIONS

STEP 1

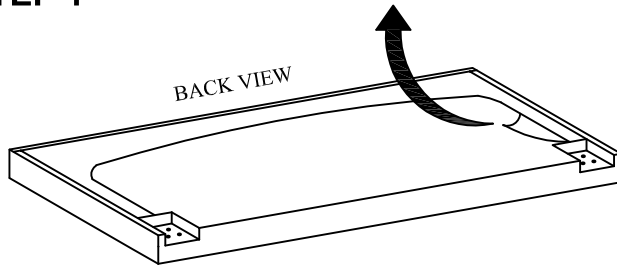

Unzip the black fabric on the back of the headboard and remove the parts. Zip the black fabric closed after parts are removed.

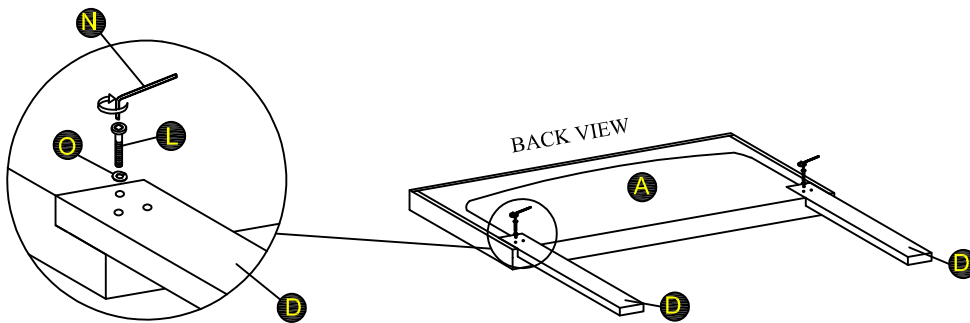

Attach Headboard Legs (Part D) to the Headboard (Part A) using three 50mm Bolts (Part L) and three Spring Washers (Part O) per leg. Secure tightly using Small Hex Key (Part N).

STEP 2

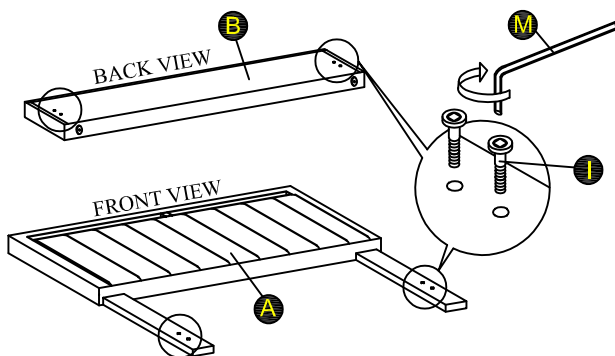

Attach the eight 20mm Bolts (Part I) to the headboard legs and footboard using the Large Hex Key (Part M). Do not tighten.

STEP 3

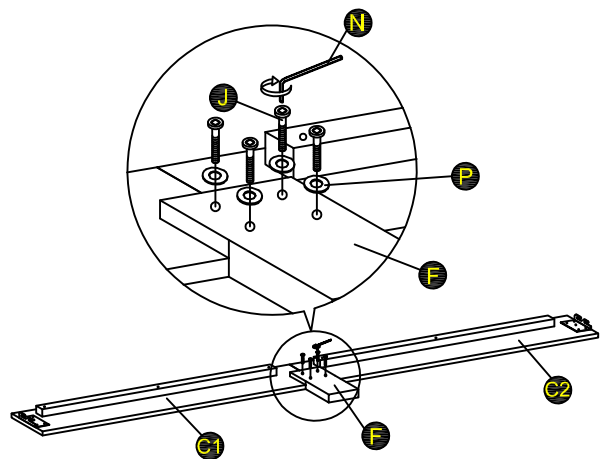

Attach the Side Rails (Parts C1 & C2) to Side Rail Leg (Part F) using four 30mm Bolts (Part J) and four Flat Washers (Part P). Secure tightly using Small Hex Key (Part N). Repeat this process for the other Side Rail.

ASSEMBLY INSTRUCTIONS

STEP 4

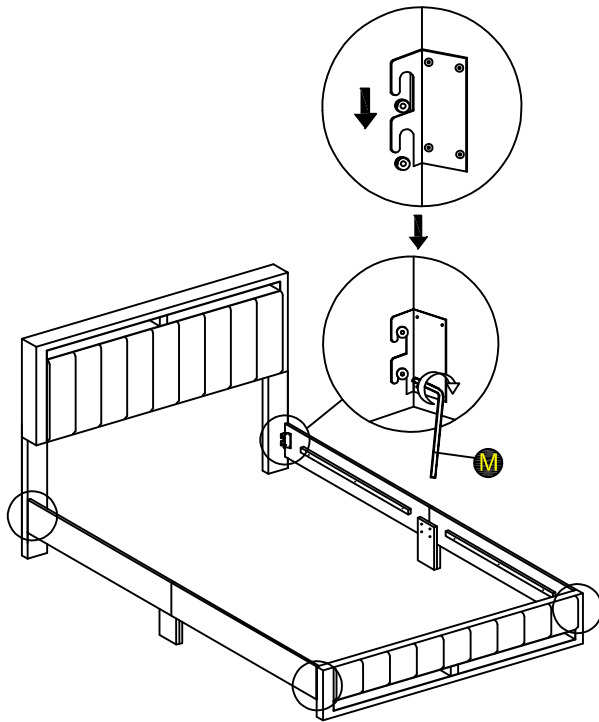

Attach the Side Rails to the Headboard (Part A) and Footboard (Part B) by sliding the side rail brackets onto the bolts on the Headboard Legs (Part D) and Footboard (Part B). Secure tightly using Large Hex Key (Part M).

STEP 5

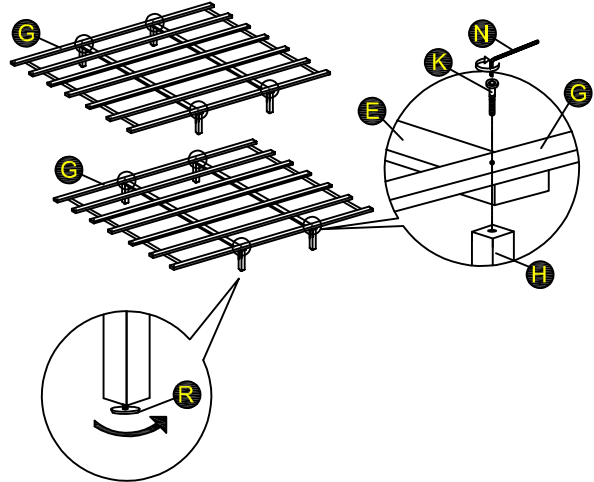

Attach the Center Legs (Part H) to the Center Rail (Part E) and Wood Slat System (Part G) using 60 mm Bolt (Part K) and Small Hex Key (Part N) to tighten. Attach the adjusters (Part R) to the Center Legs (Part H) and adjust as needed to level the bed.

STEP 6

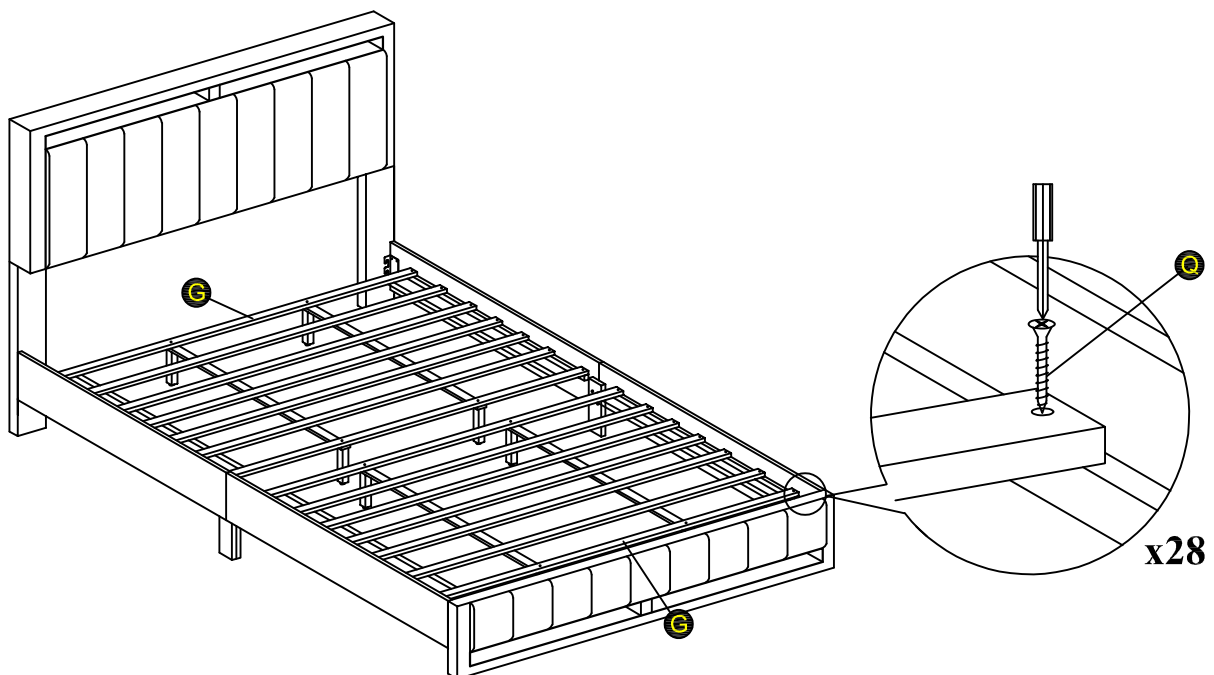

Place the Wood Slat System (Part G) into the bed as shown. Secure the Wood Slat System to the Side Rails (Part C1 & C2) using 28 Screws 32mm (Part Q) and a Phillips Head Screwdriver (Not provided). Your bed is now set up and ready for use. For Customer Support please call: 314-993-2693