











# Assembly Instructions

**Caution : You must read this before you proceed**

## Care & Maintenance



- ⊘  ● Not for commercial use. For residential use only.
  - ✓  ● Furniture may scratch floors. We recommend using furniture pads to protect your floors.
  - ⊘  ● Do not put hot items directly on furniture surface.
  - ⊘  ● Do not clean furniture with harsh cleansers or polish.
  - ⊘  ● Do not place furniture under direct sunlight.
  - ⊘  ● Do not place furniture near heating or cooling vents.
  - ⊘  ● Do not write on furniture without a padded barrier to protect the surface.
  - ⊘  ● Do not place furniture outside . For indoor use only.
  - ⊘  ● Stains may be removed with mild soap solution and damp cloth.
  - ⊘  ● Children should not climb or jump on the furniture.
- ✓  ● Dust and pick-up spills using a clean, non-colored, lint-free cloth.

Please look in chair seat for hardware packs and legs.  
Sets often ship in multiple boxes and may arrive a day or two apart.

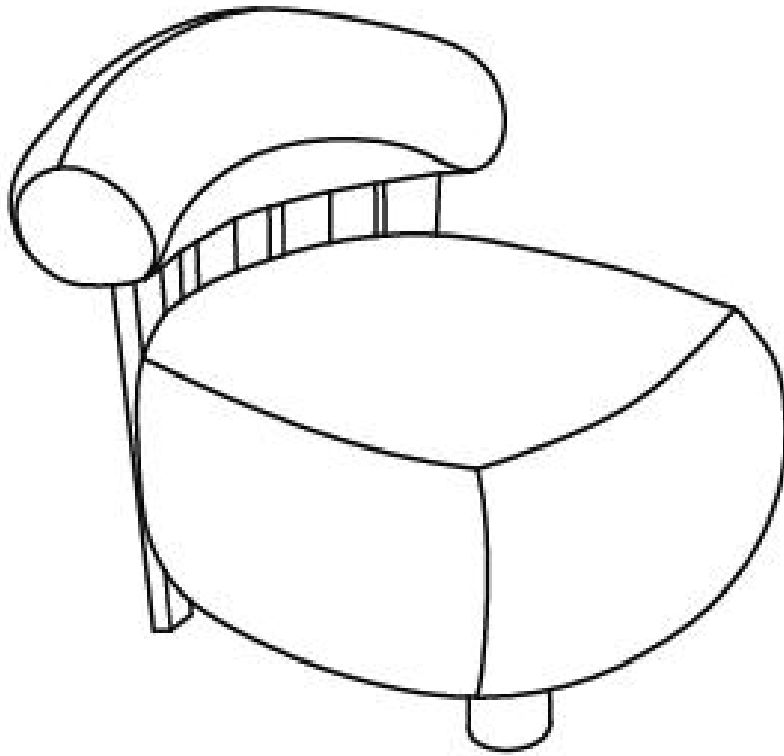



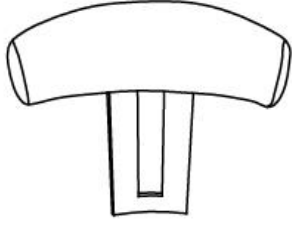
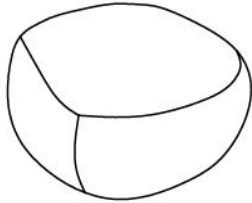

# Club Chair

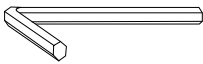

## Parts List

Label	Picture	Description	QTY
A		Backrest	1
B		Chair Seat	1
C		Front Leg	2
D		Hind Leg	2

## Hardwares

Label	Picture	Description	QTY
①		Bolt (M8*45MM)	7
②		Washer(M8)	7
③		Spring Washer(M8)	7
④		M8 Allen Wrench	1
⑤		Bolt (M6*20MM)	5
⑥		Gasket	2
⑦		M6 Allen Wrench	1

# Assembly Preparation

Before  
Beginning  
Assembly:

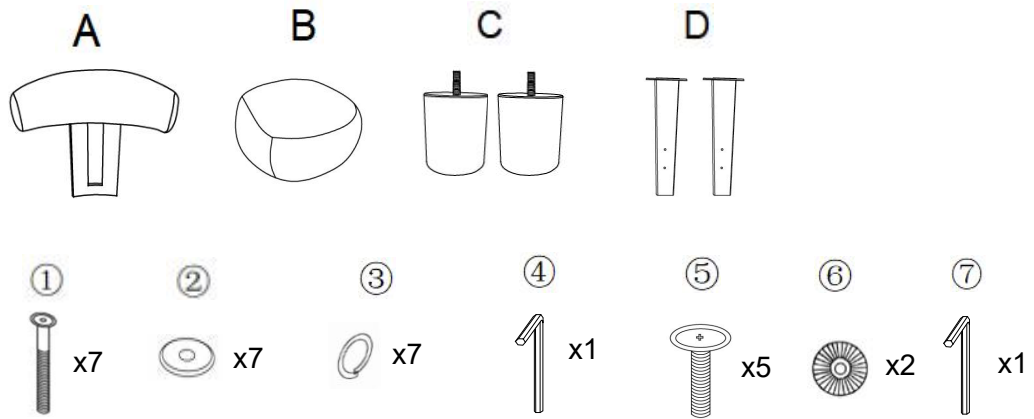

- Read instructions, cover to cover-



- Have 2 adults on hand for assembly-



- Do not assemble on flooring or carpet-



- Assemble on a clean non-marring surface (packing foam)-



- Save all packaging until finished-

# Assembly Steps

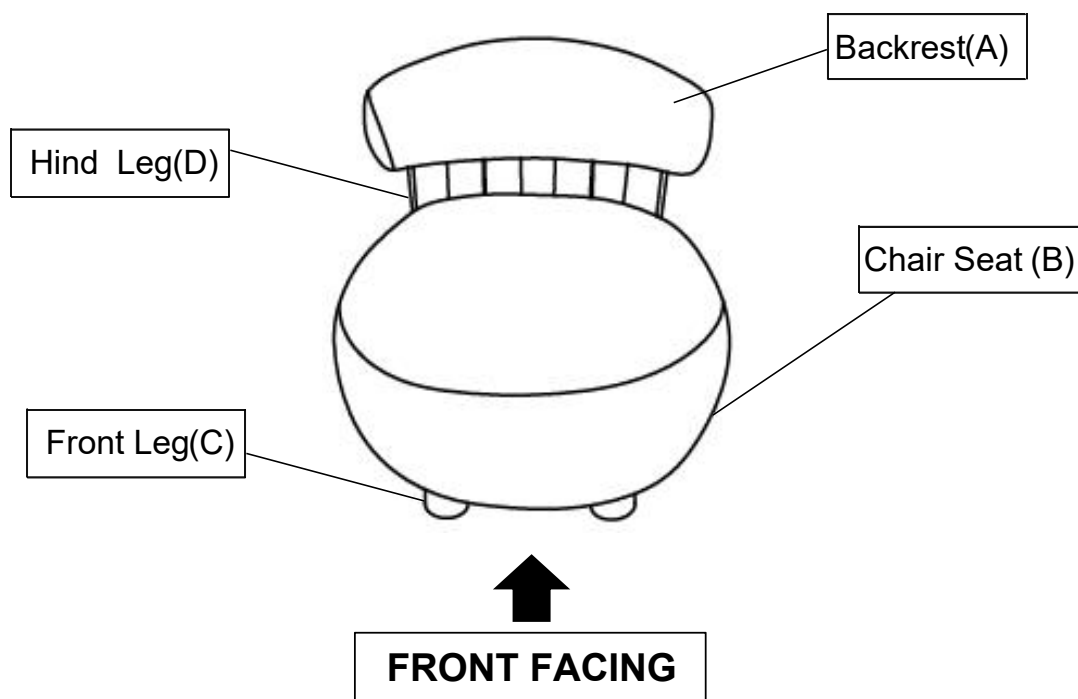

This Club Chair has multiple parts and may require up to 30 minutes to assemble.

To give you an overview of the Chair, the above picture is to help you put the various parts into perspective.

Please read through the instructions below to familiarise yourself with the parts and steps before assembly.

**Note: It is recommended that you have an adult partner to assist during the entire assembly process.**

### Step 1

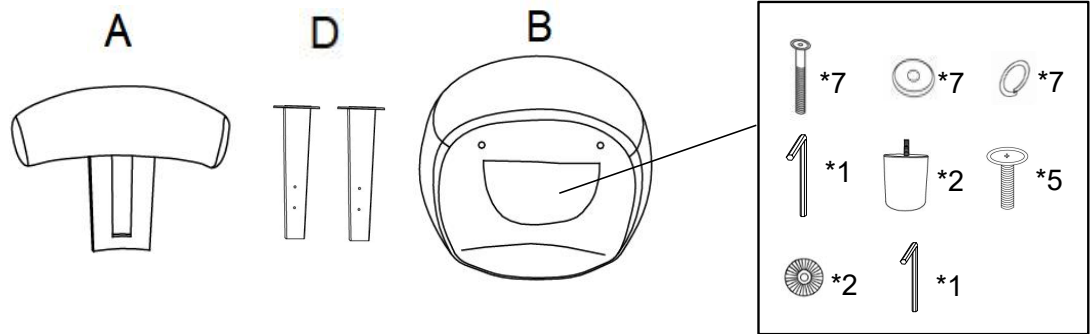

Position the Backrest(A), Chair Seat(B) and Hind Legs(D) on a clean, non-marring surface, as shown. Do not place on surface that can scratch or damage the upholstery. Take out the 2 legs and Hardwares from the bottom of Chair Seat(B).

### Step 2

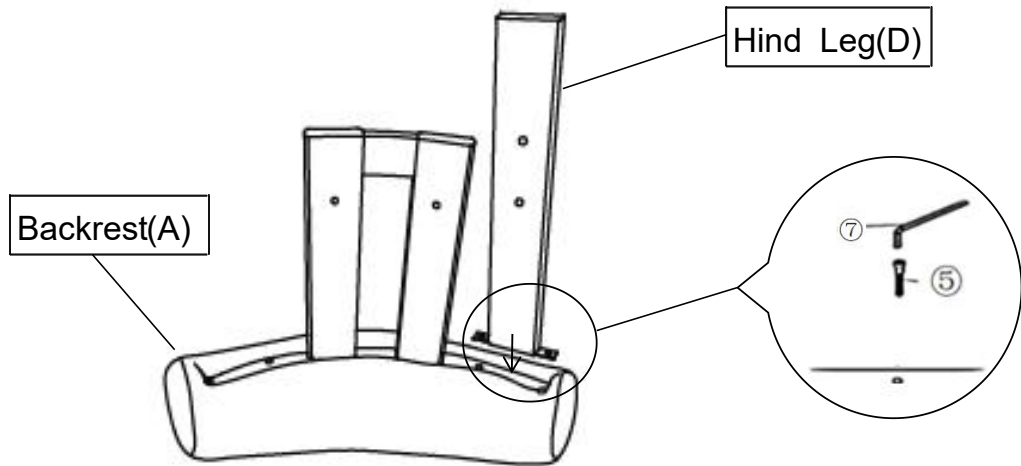

Upside down the Backrest(A) and put it on a non-marring surface, put the Hind leg(D) on the backrest, overlap the steel plates to mounting holes of the Backrest (A). Attach the Hind Leg(D) to the Backrest (A) using a Bolts(5) with the Allen Wrench (7) as pictured above.

**DO NOT fully tighten the Bolts, it will be helpful in next assembly steps.**

### Step 3

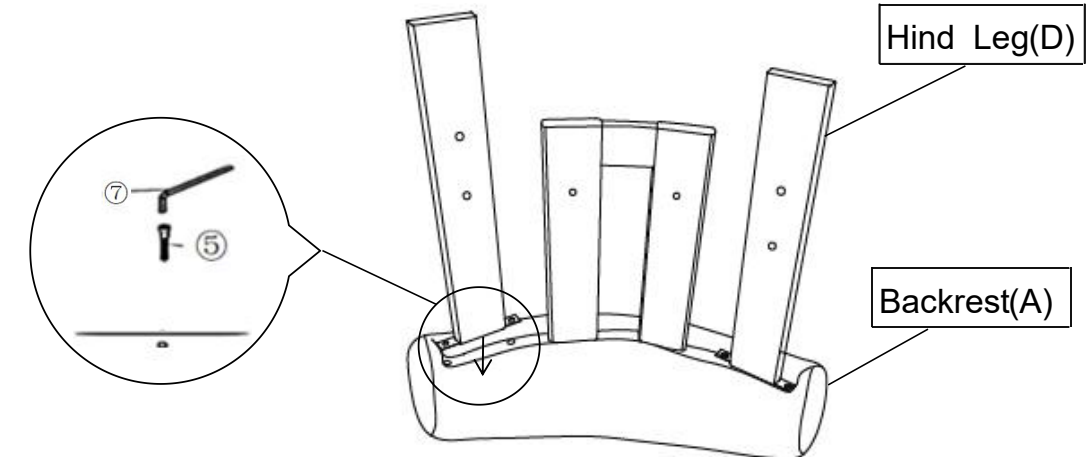

Repeat the same process as Step 2 for another Hind leg (D).

**DO NOT fully tighten the Bolts, it will be helpful in next assembly steps.**

## Step 4

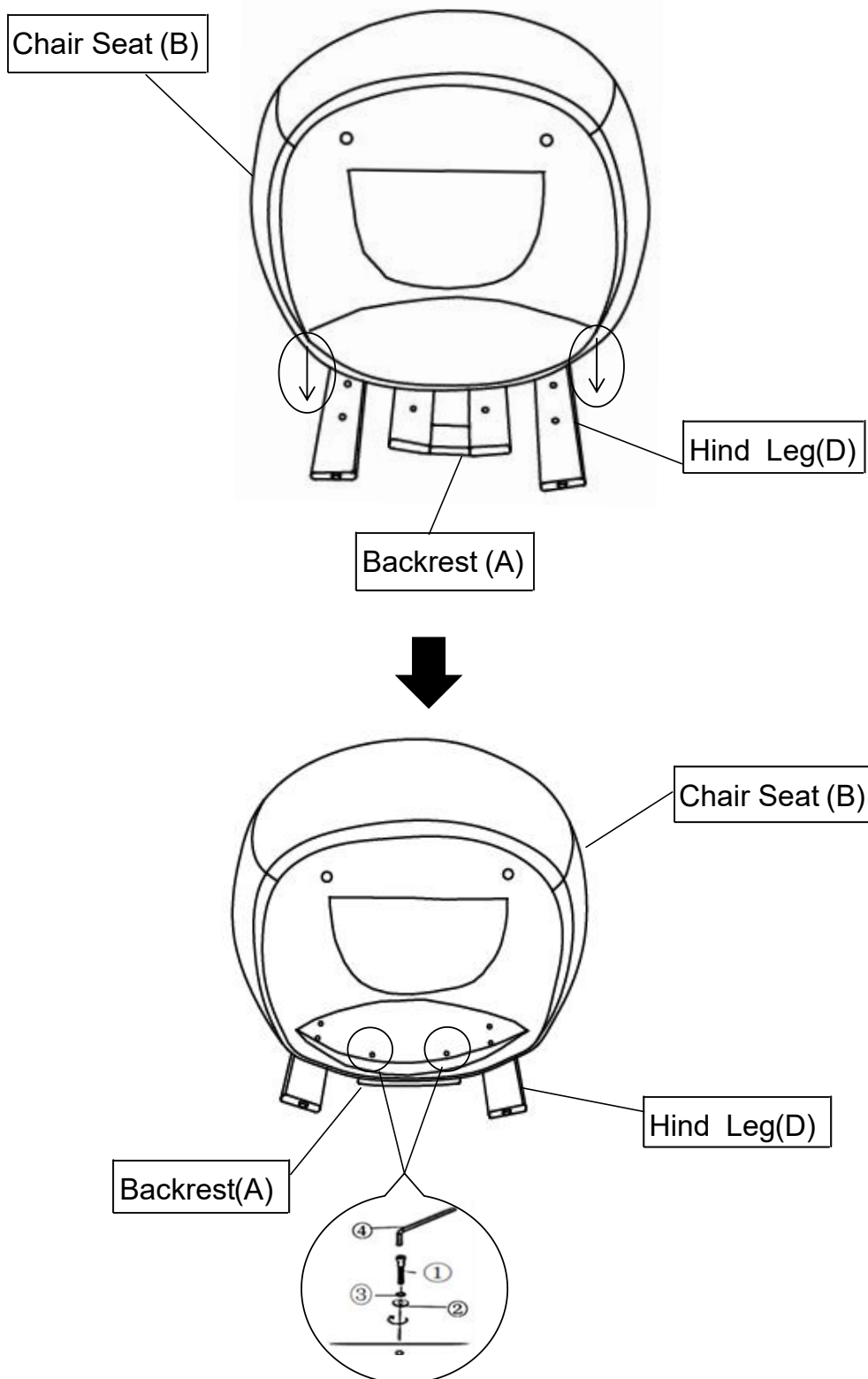

Unzip the bottom of Chair Seat (B).

Attach Chair Seat(B) to the assembled Backrest(A) using Bolts(①), Spring Washers(③), and Washers(②) with the Allen Wrench (④) as pictured above.

Screw on the 2 middle bolts.

**DO NOT fully tighten the Bolts, it will be helpful in next assembly steps.**

## Step 5

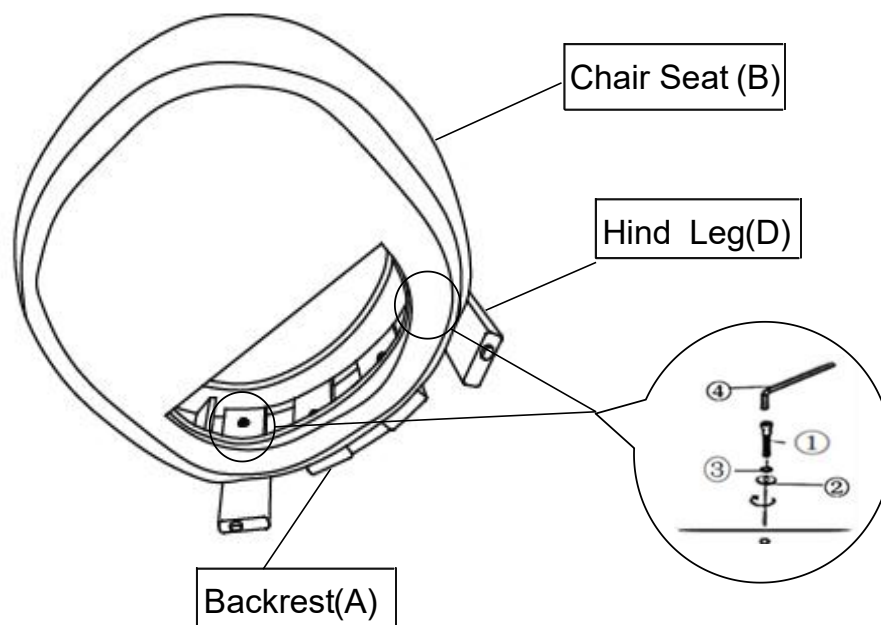

Slightly tilt the semi-assembled Chair Seat (B), screw in the bolts through Chair Seat (B) to the Hind Leg (D), using Bolts(①), Spring Washers(③), and Washers(②) with the Allen Wrench (④) as pictured above.

Repeat the process with the other Hind Leg (D).

**After all the six bolts are in place, Tighten the Bolts fully in a sequential manner.**

**DO NOT fully tighten a Bolt in one go and then move on to the next.**

**Rather, In a sequential manner, gradually tighten each Bolt until all Bolts are evenly secured.**

## Step 6

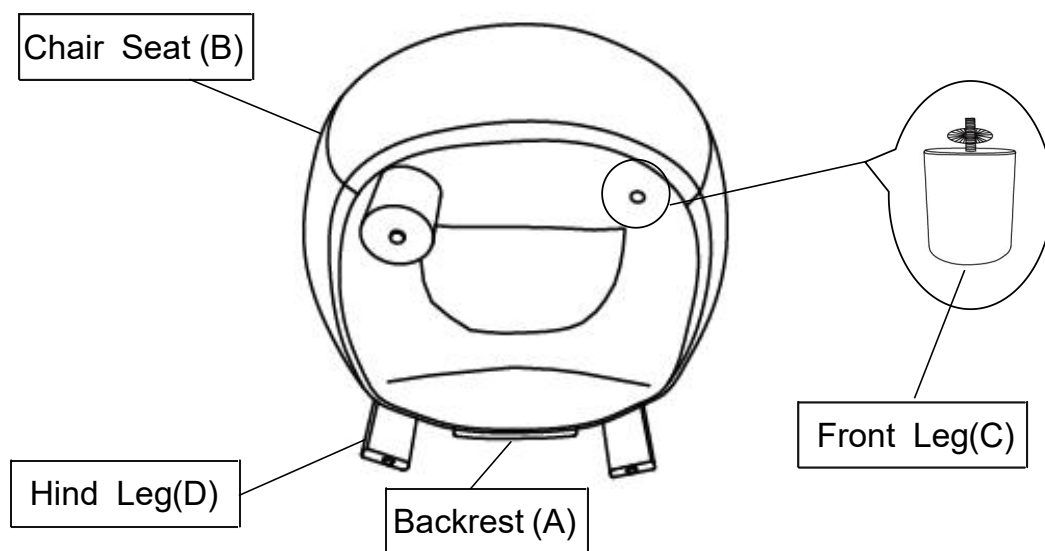

Install the Front Leg(C) into the Chair Seat(B) by placing one Gasket(⑥) onto the threaded stem. Then tighten by turning the Leg clockwise until it is completely secure.

Repeat this process with the another Front Leg(C).

**Note: The use of the Gaskets are OPTIONAL and are especially useful to help alleviate slight wobbles.**

**Some Legs may need more than one whilst some Legs may not need any.**

## Step 7

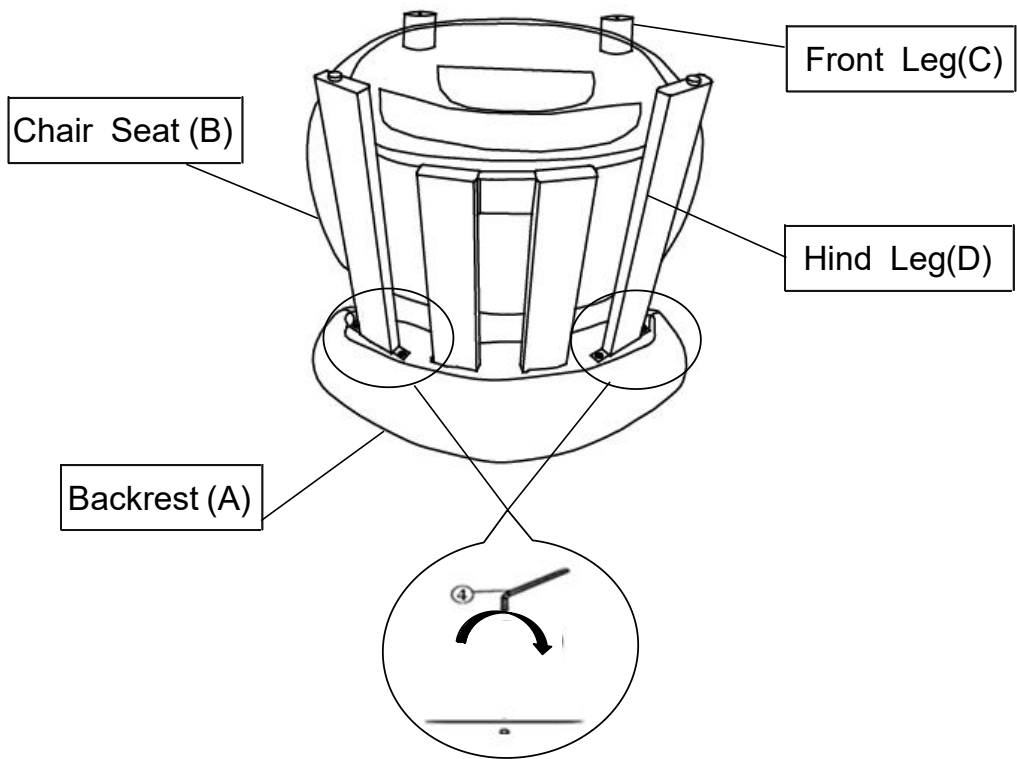

Fully tighten the bolts between the Backrest (A) and the Hind Legs (D), which processed in STEP2 &STEP3.

## Step 8

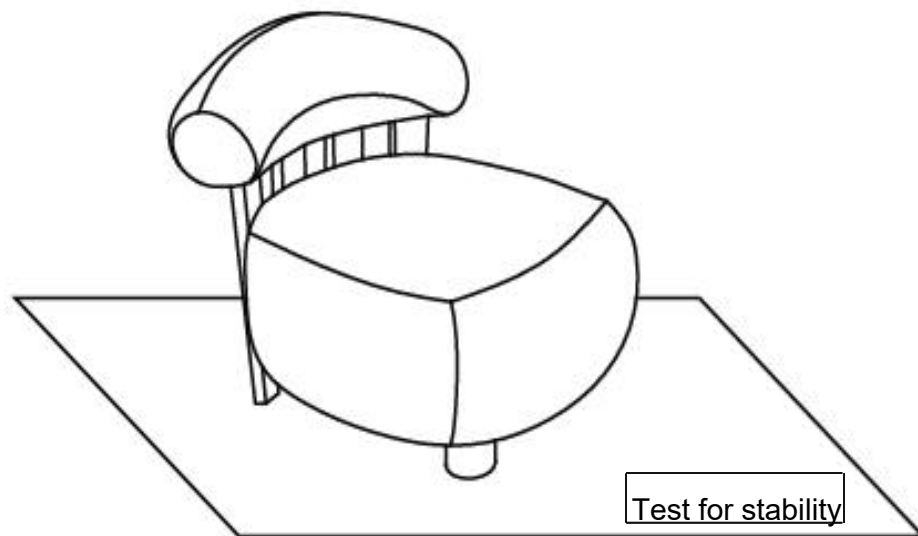

Your Club Chair is ready for use.  
This Club Chair can only be used on a flat, level surface.