







# ASSEMBLY INSTRUCTION

944-306 Jackson Panel Bed Headboard

## HARDWARE LIST 944-304

A		Threaded Bolt	Ø5/16"*4"	2 PCS
B		Curve Washer Nuts	Ø5/16"	2 PCS
C		Spanner Wrench	12MM	1 PC
D		Bolt	Ø5/16"*1-1/2'	6 PCS
E		Lock Washer	Ø5/16"	10 PCS
F		Flat Washer	Ø5/16"*19D	10 PCS
G		Allen Key	100*50*4mm	1 PC

## IMPORTANT NOTES

- . Place all wooden parts on clean and smooth surface such as rug or carpet to prevent the parts from being scratched.
- . Check to be sure that you have all parts and hardware.
- . Remove all wrapping materials, including staples and packing straps before you start to assemble.
- . Do not tighten all screws and bolts until completely assembled.
- . Keep all hardware out of the reach of children

### Instruction:

- STEP 1. Insert the two threaded bolt (A) into the headboard leg left (2) and right (3). Tighten by hand only.
- STEP 2. Insert the stretcher (4) into the threaded bolts protruding from the headboard leg (2), (3) use dowel as guide. Attach curve washer nuts (B) onto the threads and secure by hand at first. Tighten evenly using the spanner wrench (C). See Figure 1
- STEP 3. Attach the headboard panel (1) to headboard leg (2), (3) with lock washer (E), flat washer (F) and bolt (D). Five pieces per leg. Tighten the bolts using allen key (G). See Figure 2

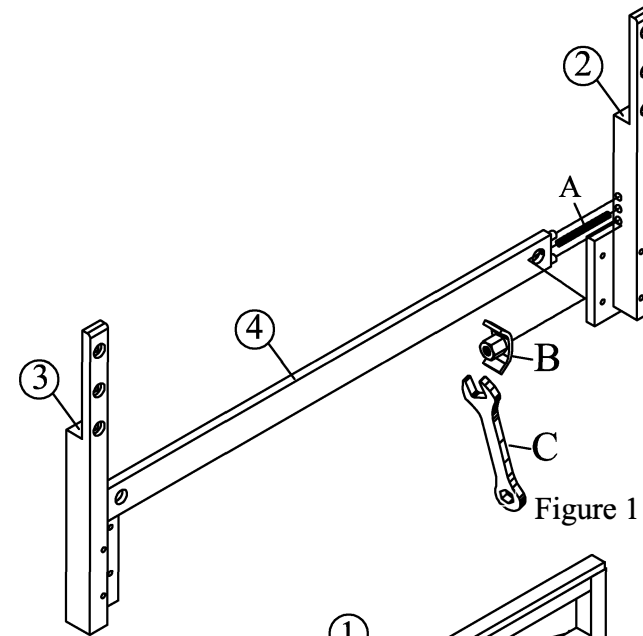

Figure 1

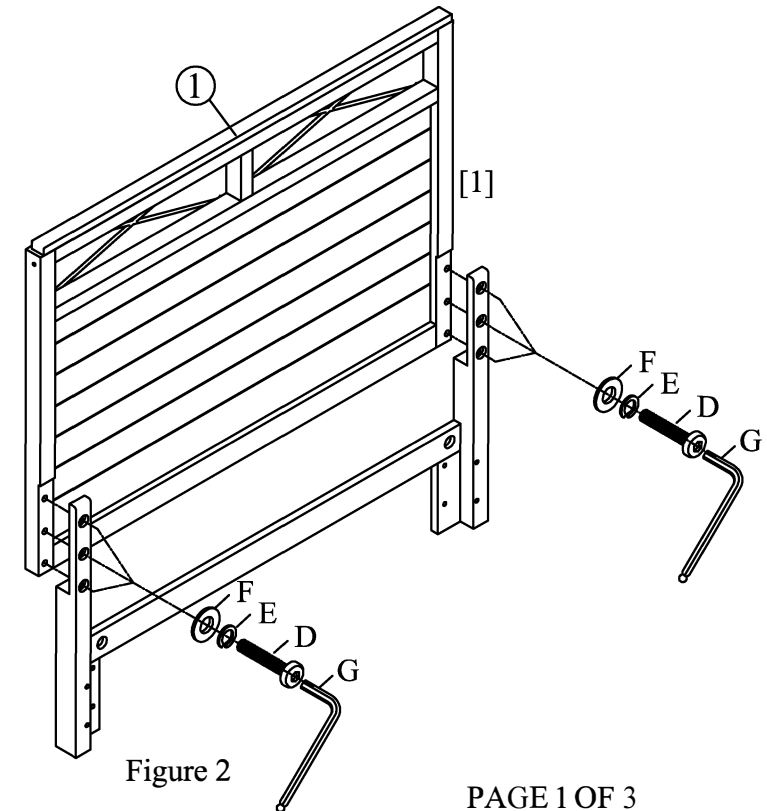

Figure 2

MADE IN VIETNAM





PAGE 1 OF 3

# ASSEMBLY INSTRUCTION

944-306P

Jackson Panel Bed King Bed

## HARDWARE LIST 944-R42

HARDWARE LIST 944-R42				
A		Threaded Bolt	Ø5/16"*4"	8 PCS
B		Curve Washer Nuts	Ø5/16"	8 PCS
C		Spanner Wrench	12MM	1 PC
D		Screw	Ø8"*1-1/4"	10 PCS

## IMPORTANT NOTES

- . Place all wooden parts on clean and smooth surface such as rug or carpet to prevent the parts from being scratched.
- . Check to be sure that you have all parts and hardware.
- . Remove all wrapping materials, including staples and packing straps before you start to assemble.
- . Do not tighten all screws and bolts until completely assembled.
- . Keep all hardware out of the reach of children

### Instruction:

**STEP 1.** Screw the bolts (A) into the two threaded holes that are at the bottom of the posts of bolt the headboard and the footboard. Slide the bed rail onto the two bolts (A) on one of the bed posts until the bolts (A) are visible through the holes on the inside of the bed rail. See Figure 1.

**STEP 2.** Slide a curve washer nuts (B) onto the bolts (A) through the holes in the bed rail. Tighten all the curve washer nuts (B), using the spanner wrench (C). See Figure 1.

**STEP 3.** Assemble the leg supports to the bed slats. See Figure 2.



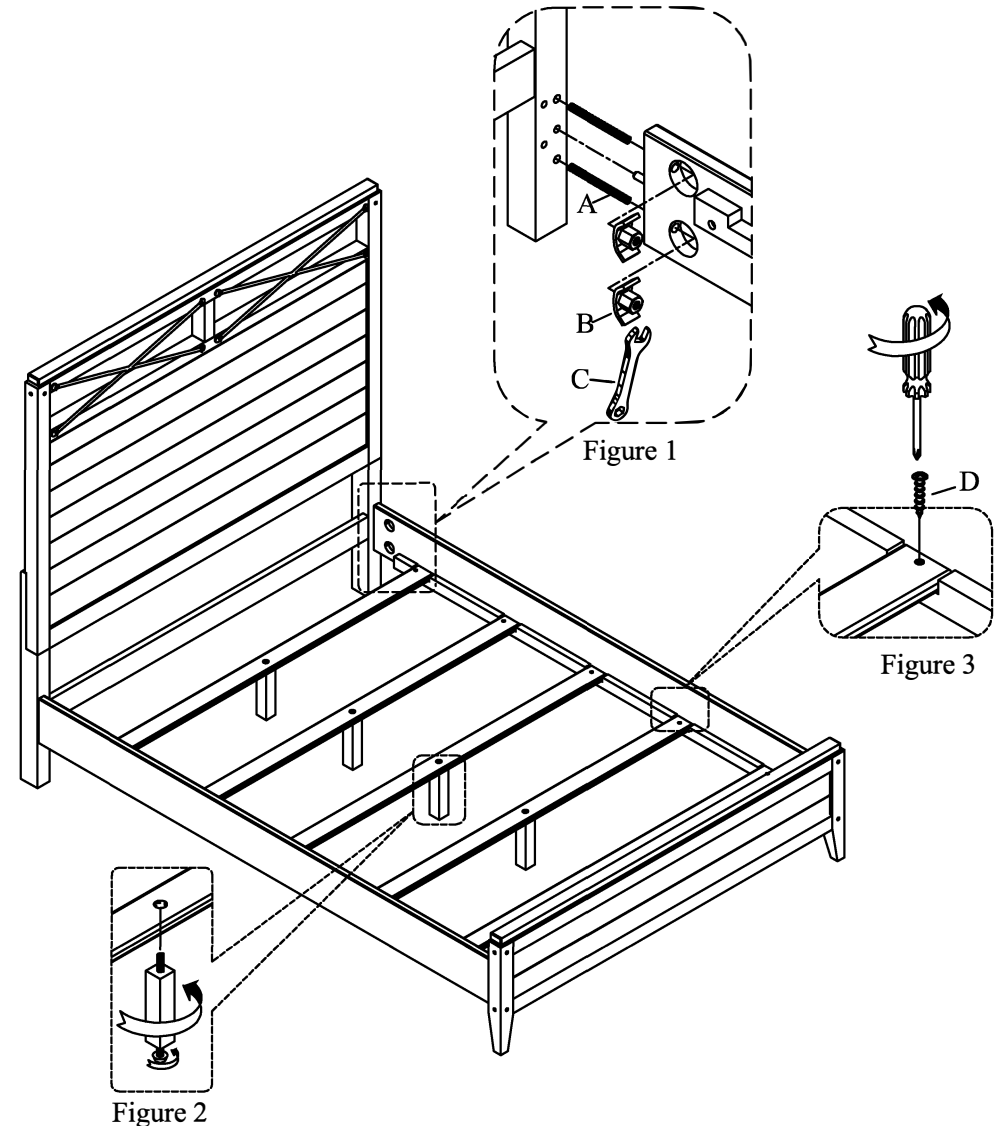

**STEP 4.** Mount the assembled support slats onto the side rail with screws (D). Then use a phillips head screwdriver to tighten screws. See Figure 3.



# ASSEMBLY INSTRUCTION

944-304 Jackson Panel Bed Headboard 5/0  
 944-306 Jackson Panel Bed Headboard 6/0-6/6  
 944-313 Longview Upholstered Bed Headboard 5/0  
 944-306 Longview Upholstered Bed Headboard 6/0-6/6  
 944-324 Linden Panel Bed Headboard 5/0  
 944-326 Linden Panel Bed Headboard 6/0-6/6

## HARDWARE LIST

A		Bolt	Ø1/4"*3-3/4"	4 PCS
B		Flat Washer	Ø1/4"*19D	8 PCS
C		Lock Washer	Ø1/4"	4 PCS
D		Nut	Ø1/4"	4 PCS

## IMPORTANT NOTES

- . Place all wooden parts on clean and smooth surface such as rug or carpet to prevent the parts from being scratched.
- . Check to be sure that you have all parts and hardware.
- . Remove all wrapping materials, including staples and packing straps before you start to assemble.
- . Do not tighten all screws and bolts until completely assembled.
- . Keep all hardware out of the reach of children

