

ASSEMBLY INSTRUCTIONS

ITEM NO.WF282360

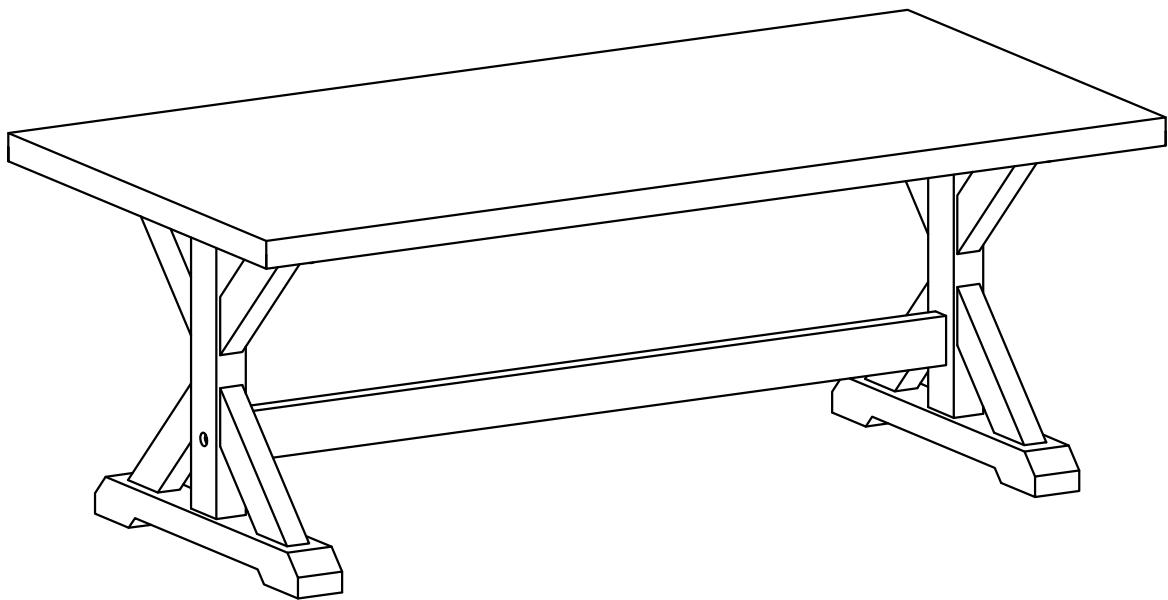



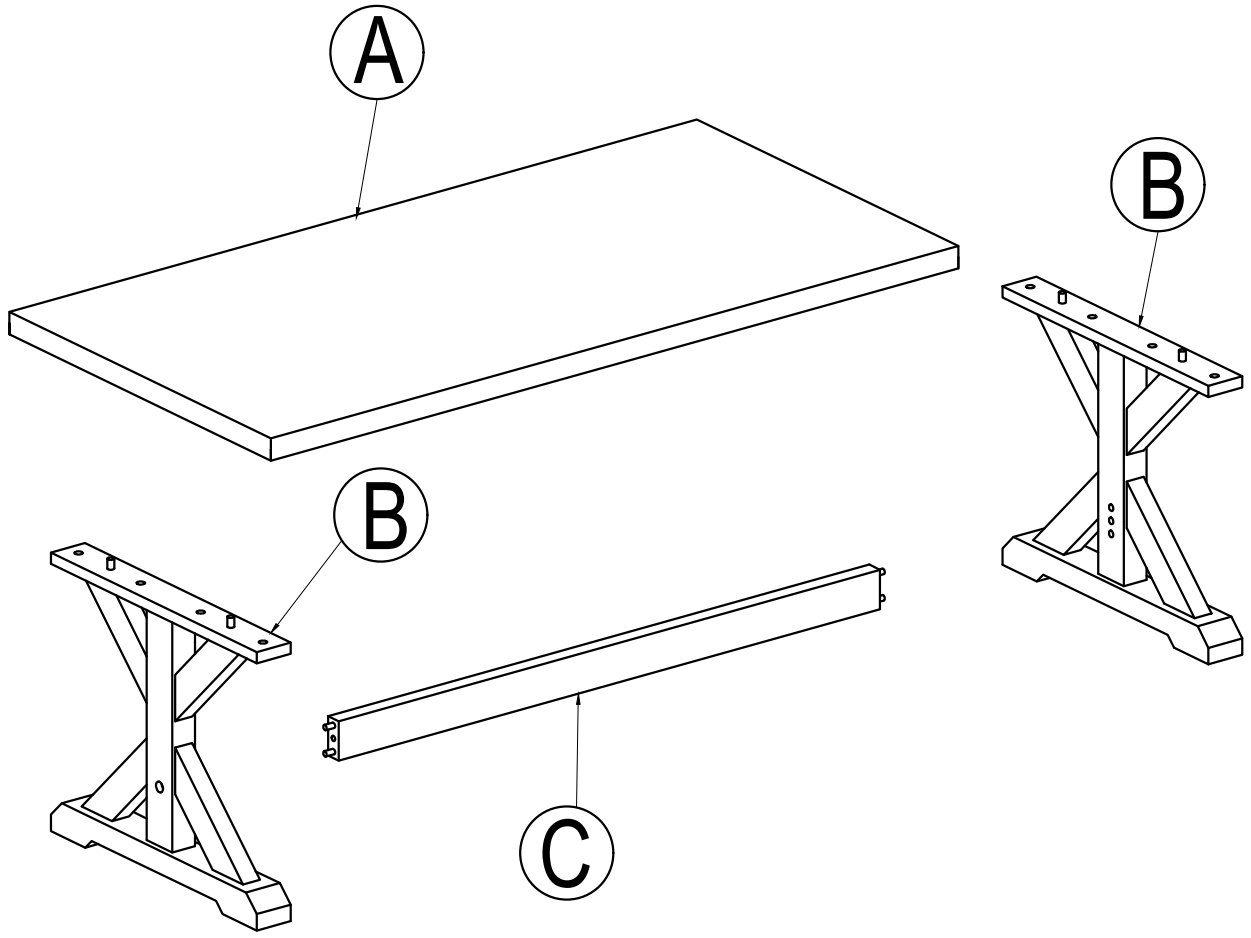

IMPORTANT NOTE :

- ① PLACE ALL PARTS ON A CLEAN AND SMOOTH SURFACE SUCH AS A RUG OR CARPET TO AVOID THE PARTS FROM BEING SCRATCHED.
- ② BEFORE YOU BEGIN,KINDLY FOLLOW THE ASSEMBLY INSTRUCTIONS STEP BY STEP.
- ③ DO NOT TIGHTEN ALL SCREWS AND BOLTS UNTIL THE CHAIR IS FULLY SET-UP.

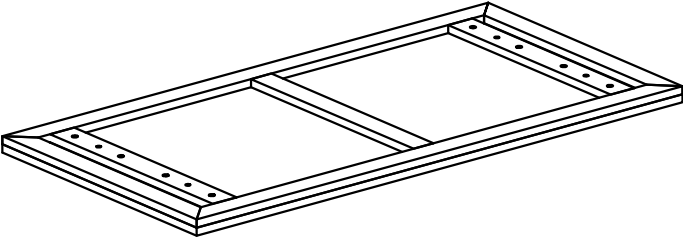
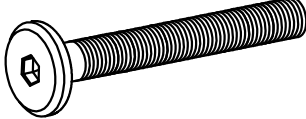
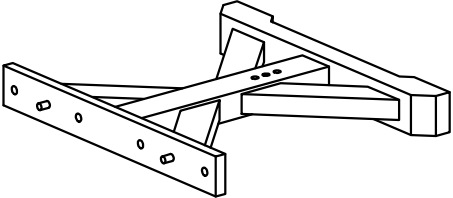

Part List

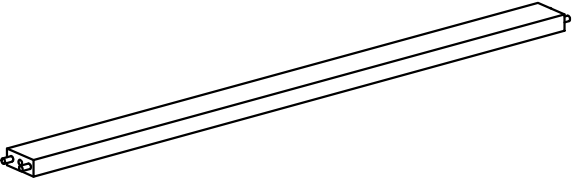
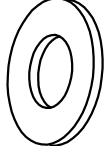
Hardware List

<p>(A)</p> 	<p>(1)</p>  <p>Ø 5/16" x 40 mm</p>
<p>TABLE TOP (1 pc)</p>	<p>BOLT (10 pcs)</p>
<p>(B)</p> 	<p>(2)</p>  <p>Ø5/16" x 13 mm</p>
<p>TABLE LEG (2 pcs)</p>	<p>FLAT WASHER (10 pcs)</p>
<p>(C)</p> 	<p>(3)</p>  <p>Ø5/16" x 19 mm</p>
<p>STRETCHER (1 pc)</p>	<p>LOCK WASHER (8 pcs)</p>
	<p>(4)</p>  <p>4 mm</p>
	<p>ALLEN KEY (1 pc)</p>

STEP 1:

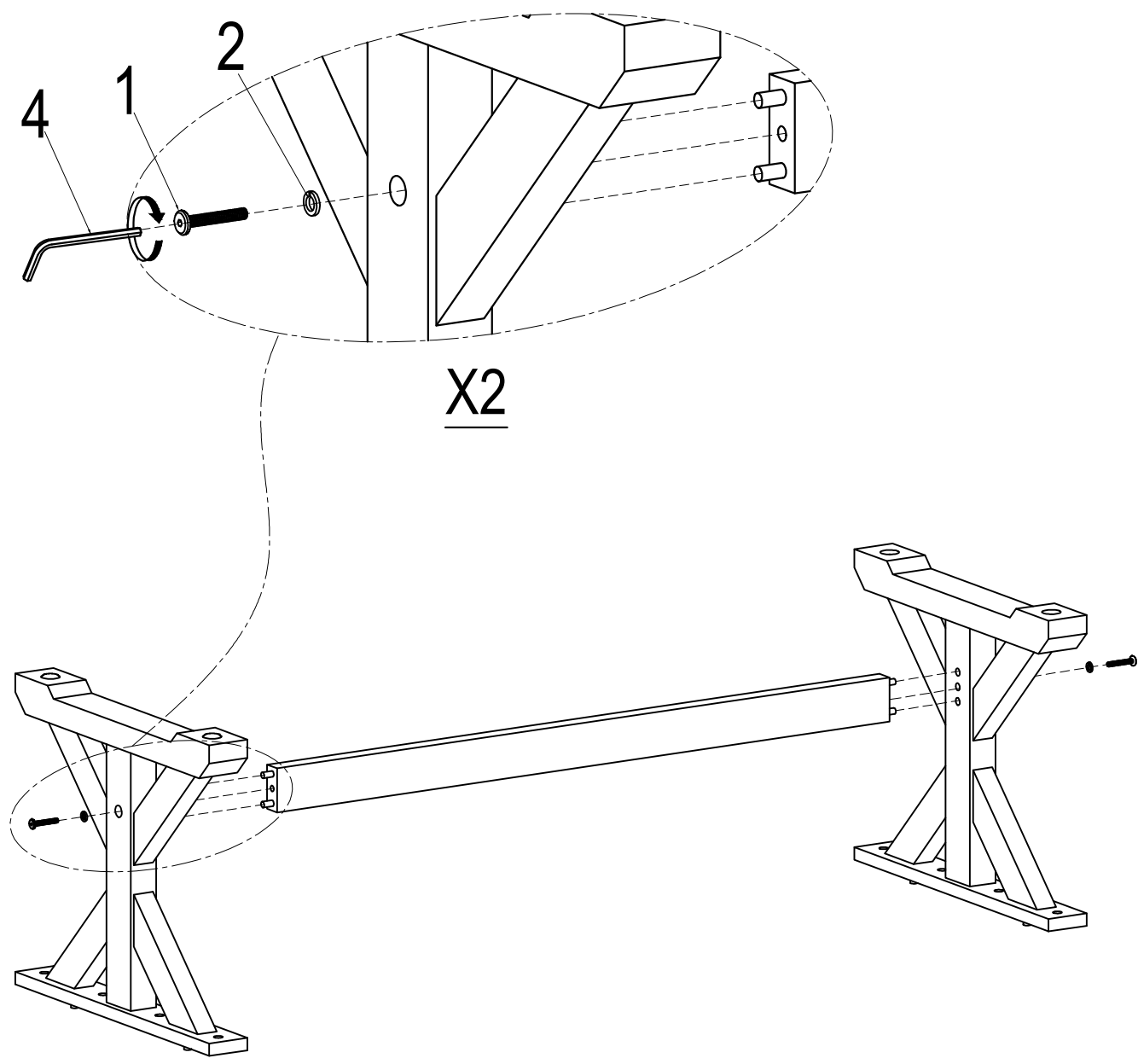

STEP 2:

