

Assembly Instructions

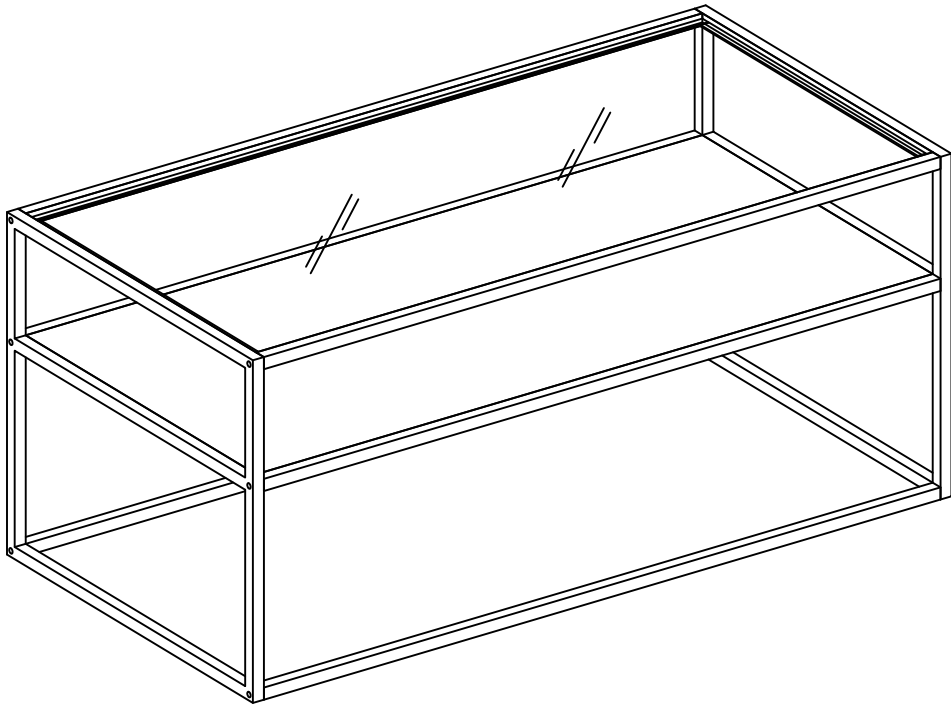

General Assembly Guidelines

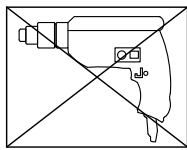



- I. Ensure that all parts and hardware are available before beginning assembly.
- II. Follow each step carefully to ensure the proper assembly of this product.
- III. Two people are recommended for ease in the assembly of this product.
- IV. The main type of hardware used to assemble this product is: bolts.
- V. Power tools should not be used to assemble this product .

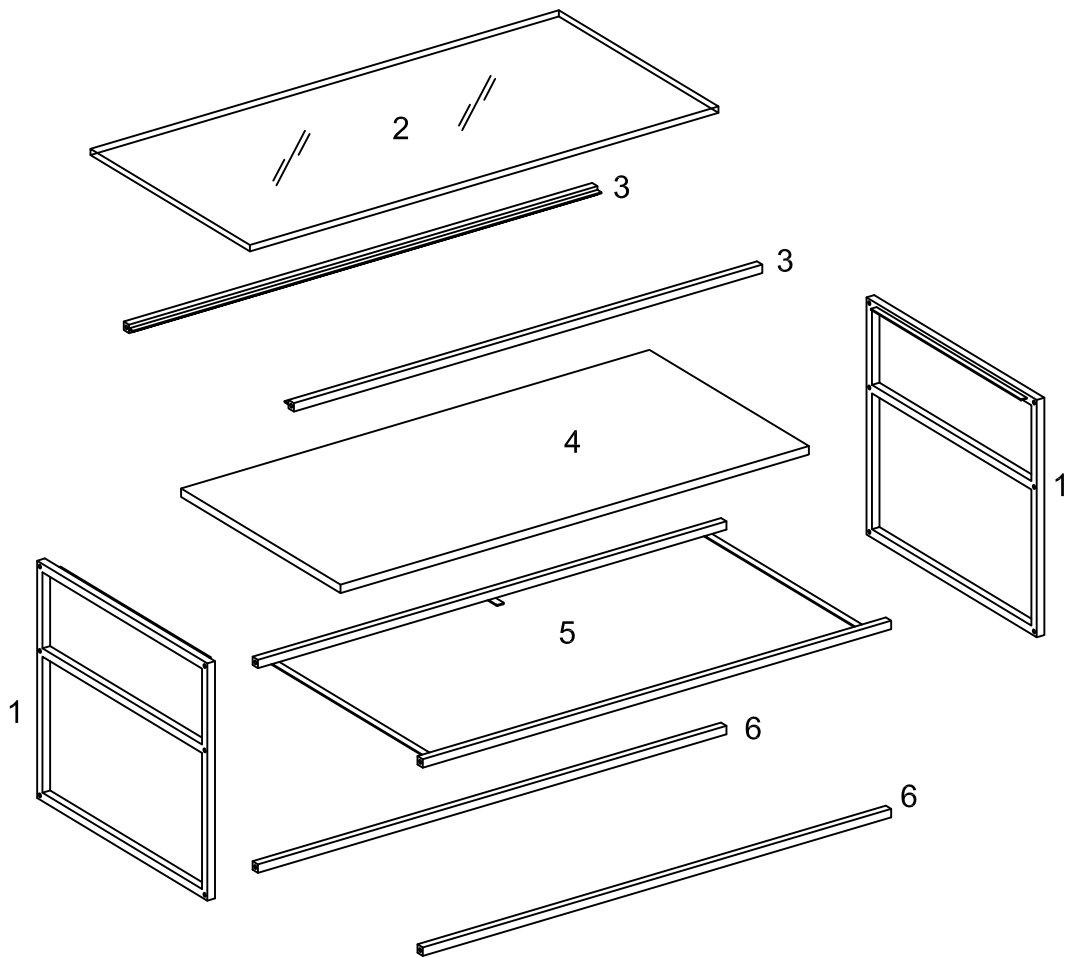

Parts List



Hardware List

A		Ø1/4"x25mm	Bolt	12 pcs
B		Ø1/4"x16	Adjustable foot	4 pcs
C		30x10mm	Glass pads	10 pcs
D		4mm	Hex Key	1 pc

*The hardware quantities listed above are required for proper assembly.
Some extra hardware may also have been included.*

Step 1

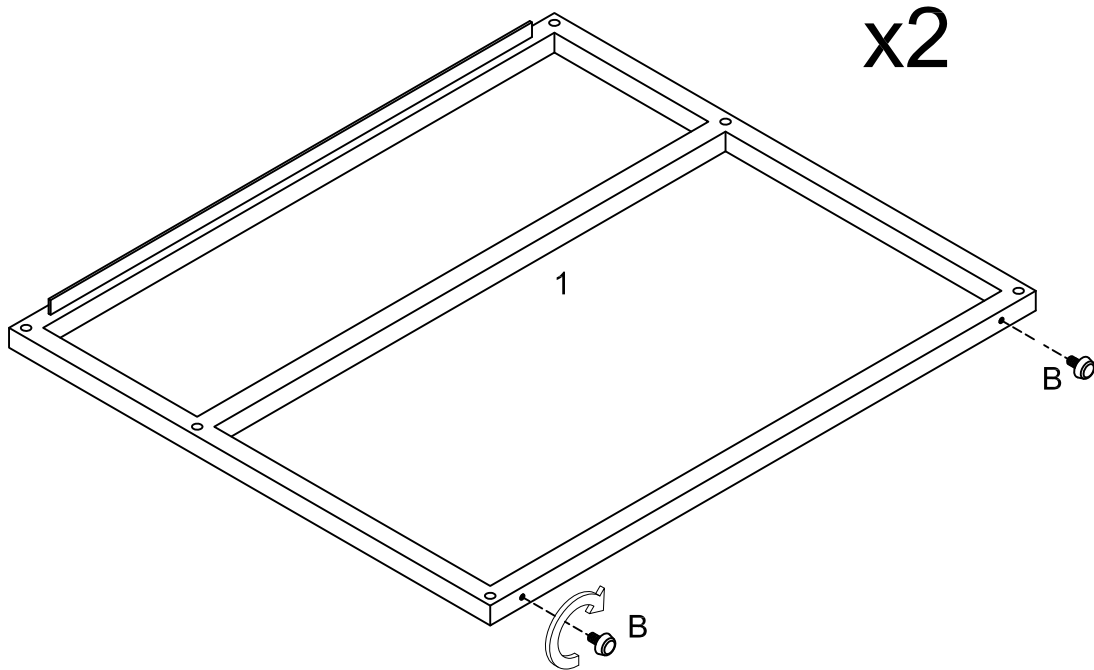

Screw adjustable foot (B) to part (1).

Step 2

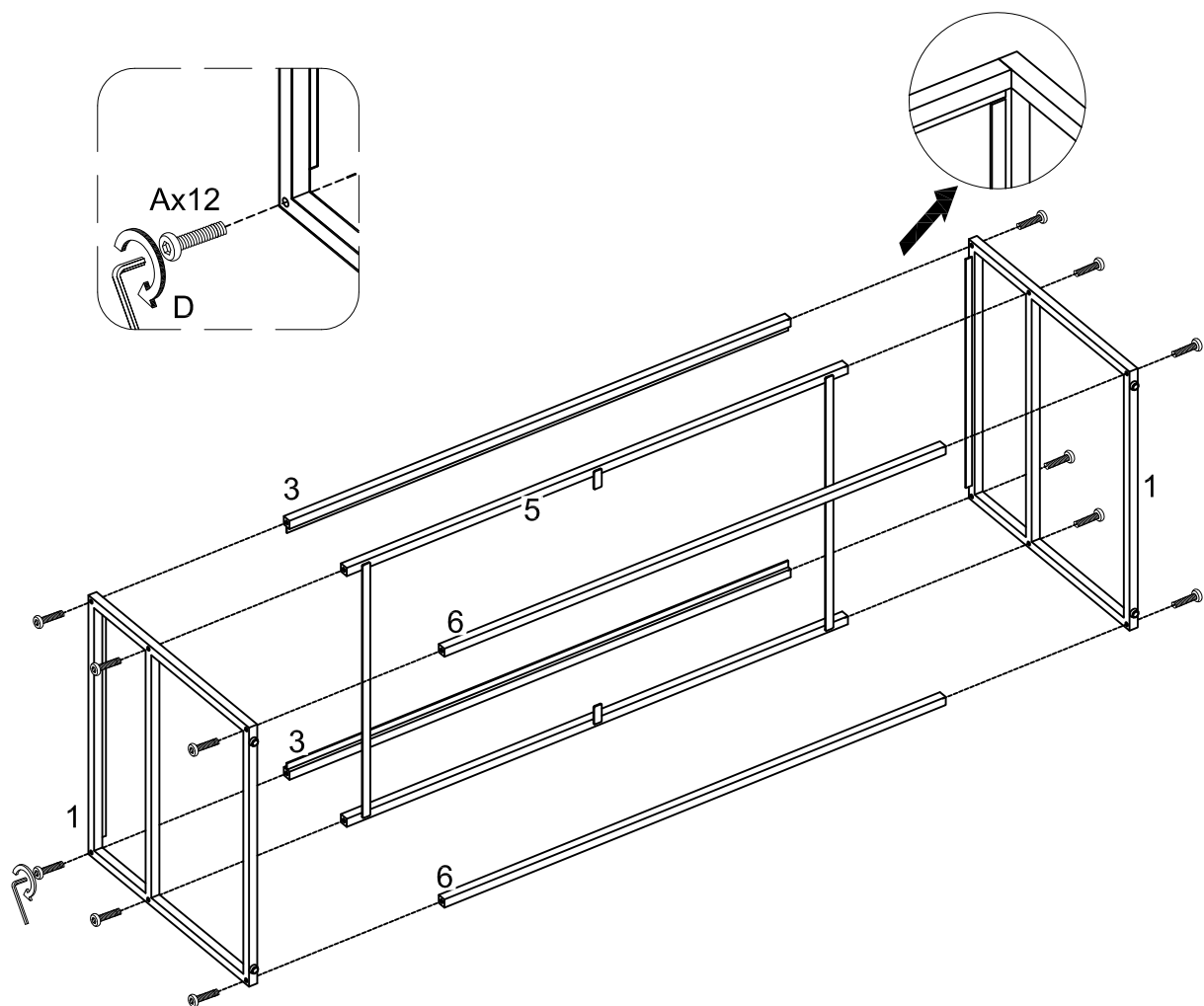

Attach part (3, 5, 6) to part (1) using bolt (A) with hex key (D).

Step 3

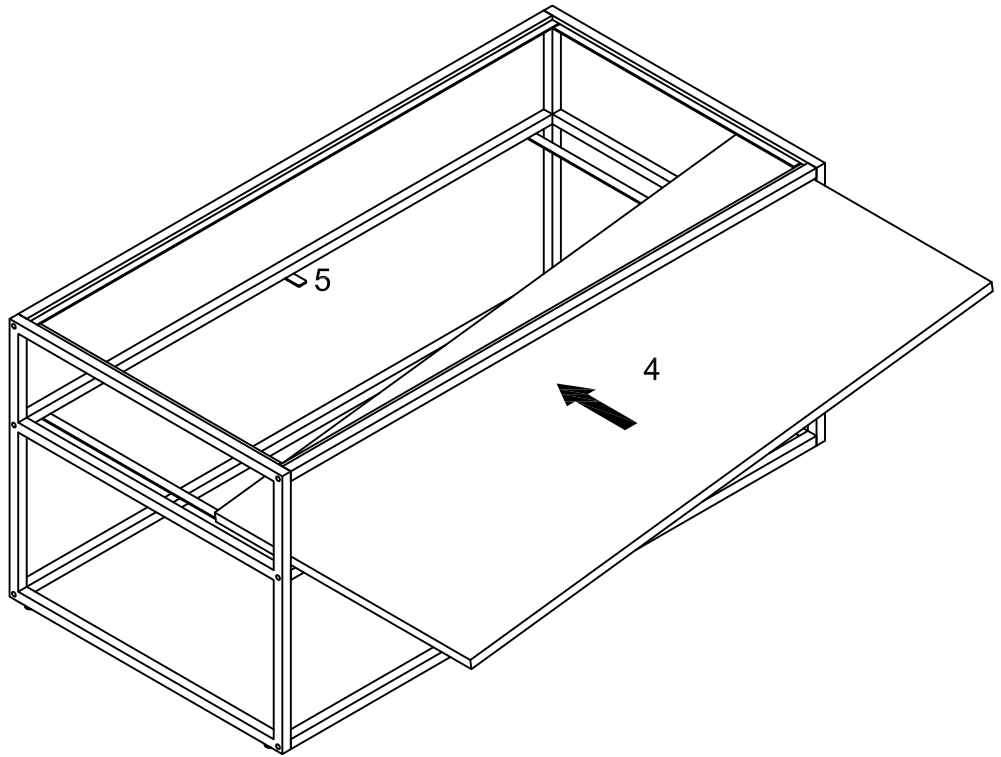

Place part (4) onto part (5) carefully. Part (4) is reversible.

Step 4

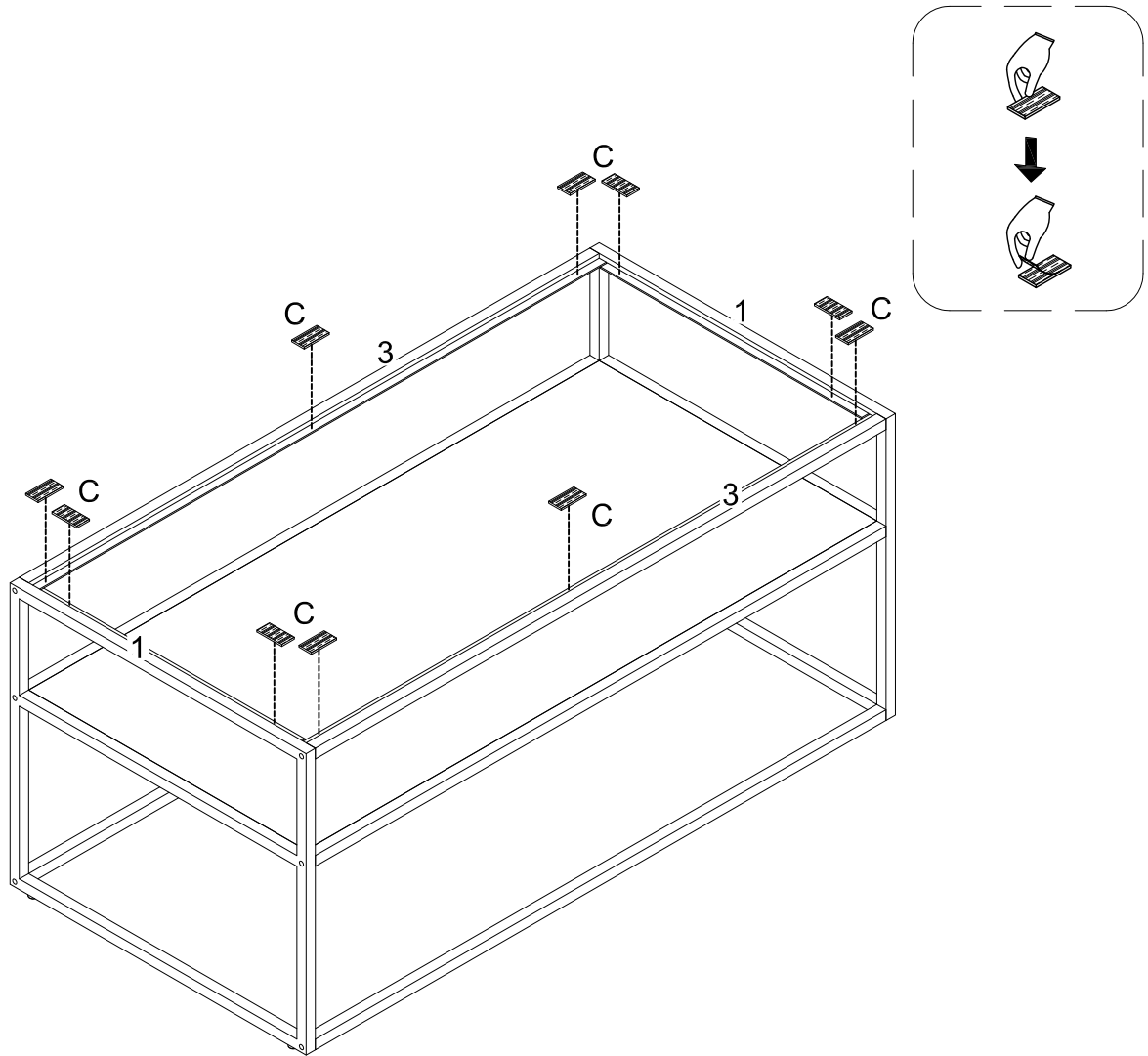

Remove cover tape on glass pads (C), then stick it as diagram.

Step 5

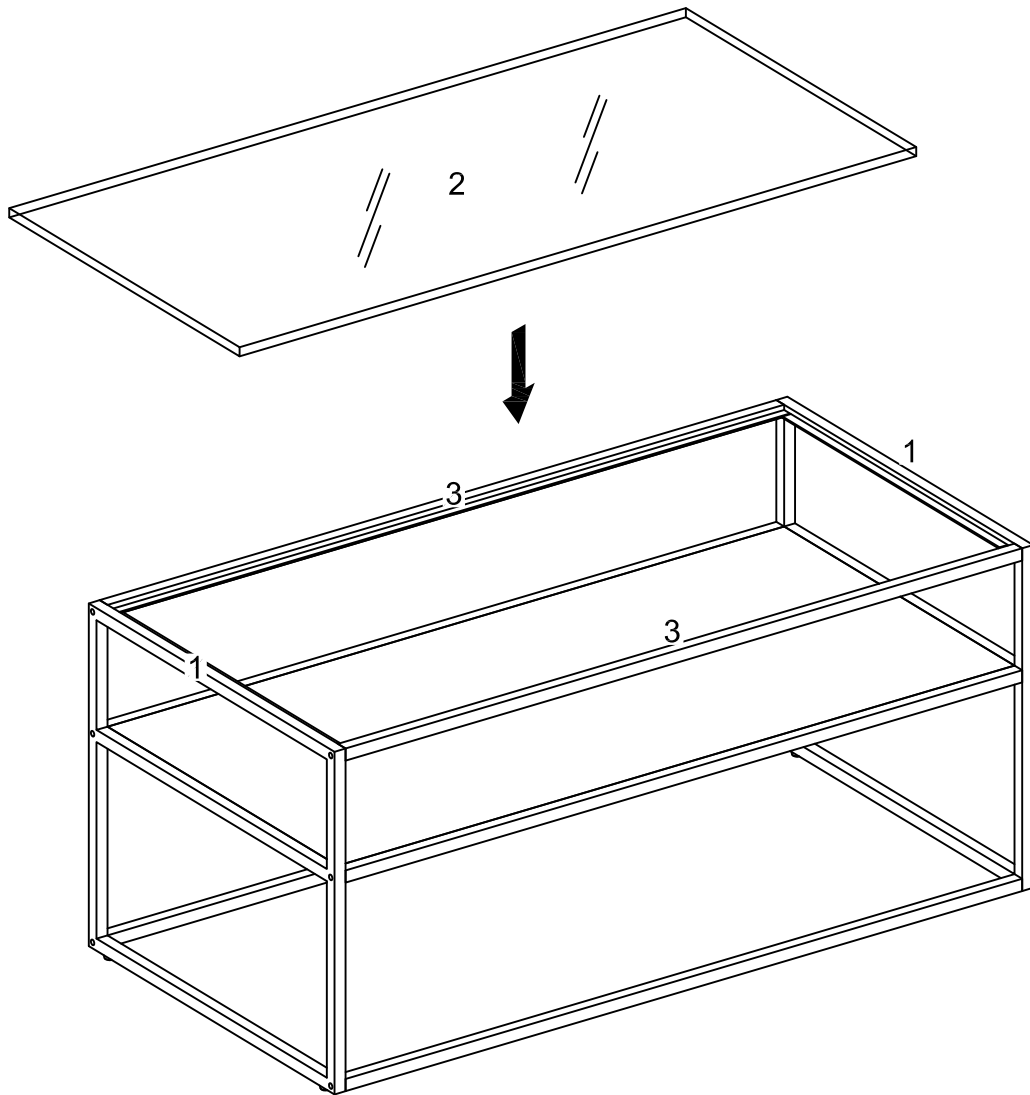

Place glass (2) onto part (1, 3) as per diagram carefully.

Step 6

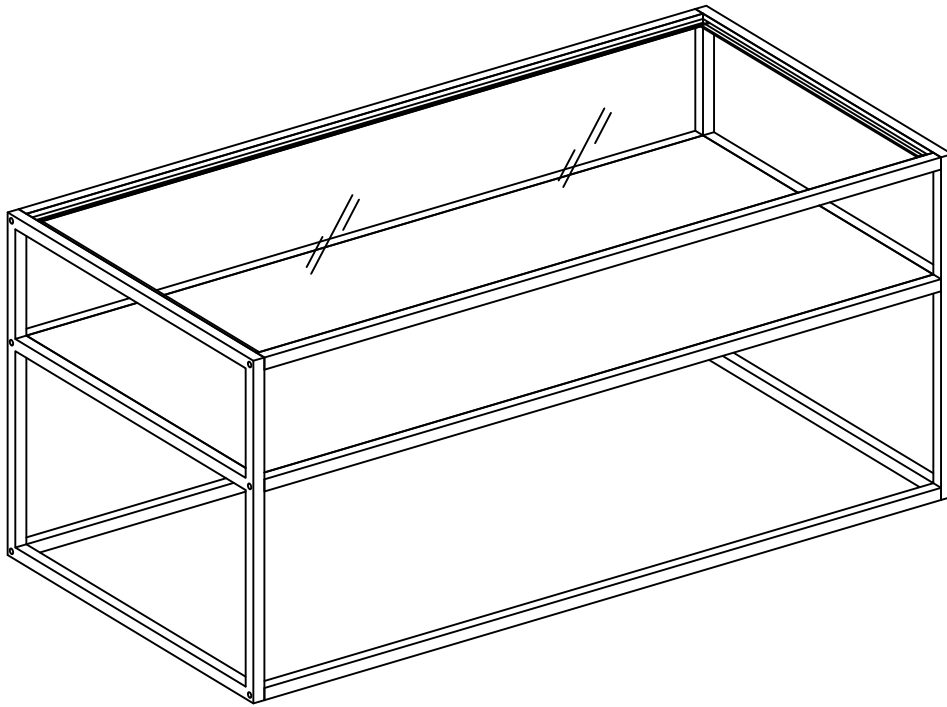

Final Assembly