

Assembly Instructions

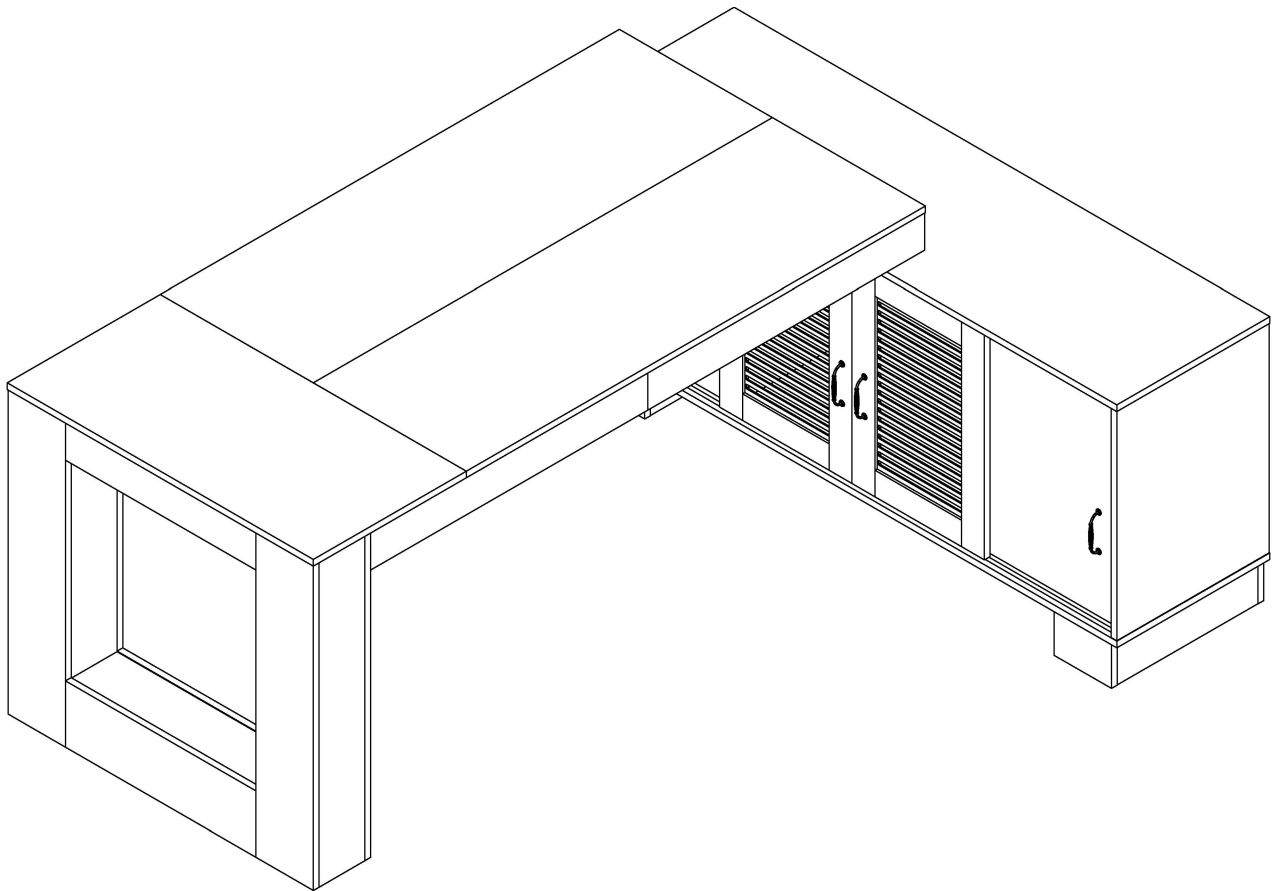

Executive Desk

Executive Desk

Contact Us

We're here to help you.

Your satisfaction is our top priority. If you encounter any issues with this product, such as missing or damaged parts, we're here to help. Please retain the original packaging and take photos of the packaging and the product, then contact us as soon as possible.

Warm Tips

1. Carefully read these instructions and keep them for future reference.
2. Check the parts list and confirm everything's there before starting assembly.
3. When assembling, put all parts on a soft, smooth surface like a carpet to avoid scratches.
4. Don't fully tighten screws until all parts are confirmed in place to avoid misalignment.

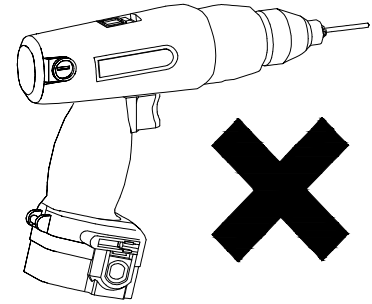
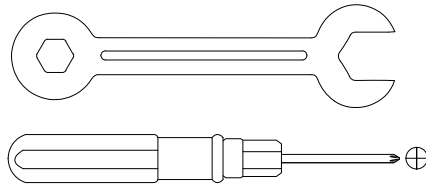
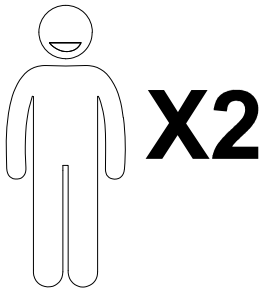

We recommend using hand tools for assembly.

If an electric screwdriver is used, reduce power and torque to avoid damage to the product.

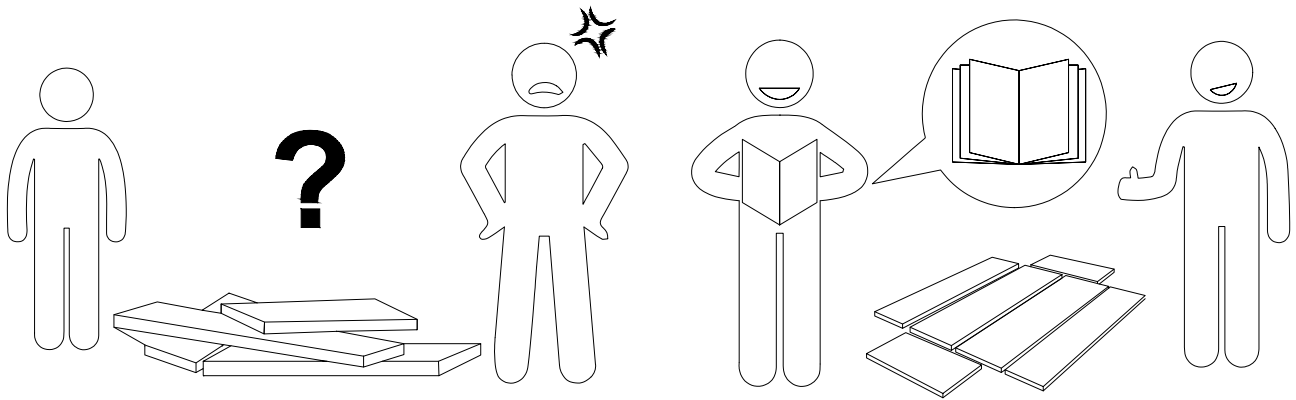

AVOID SCRATCHES

In order to avoid scratching this furniture should be assembled on a soft layer-could be a rug.

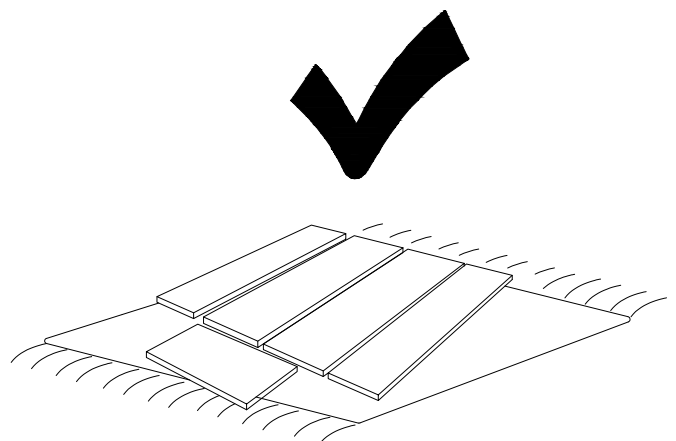
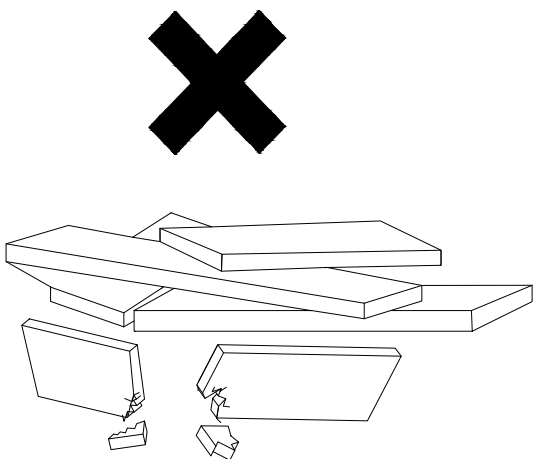

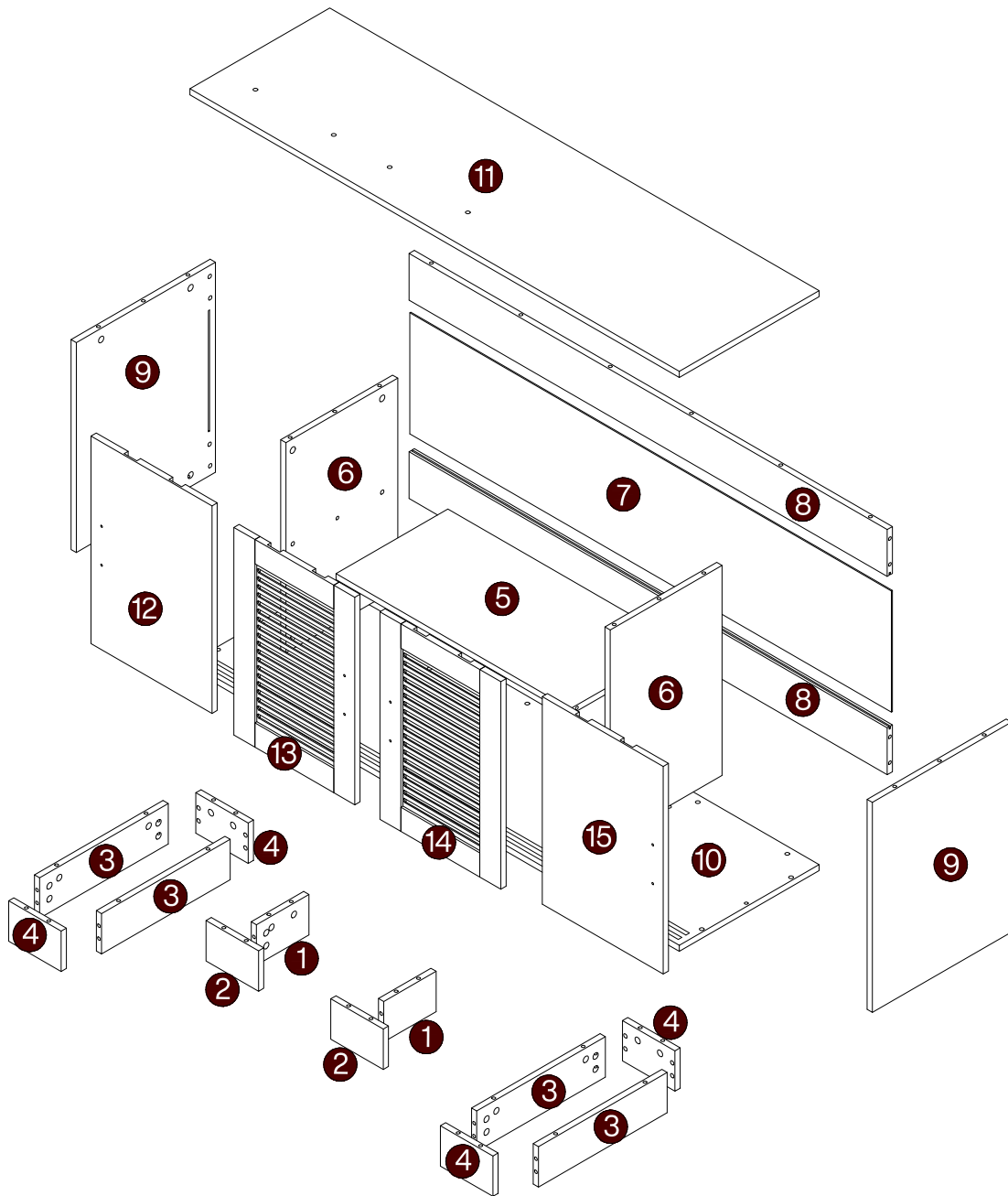

⚠ Caution

Make sure all parts are included. Most board parts are labeled or stamped on the raw edge. Contact us for a free replacement if you encounter any damaged or missing parts.

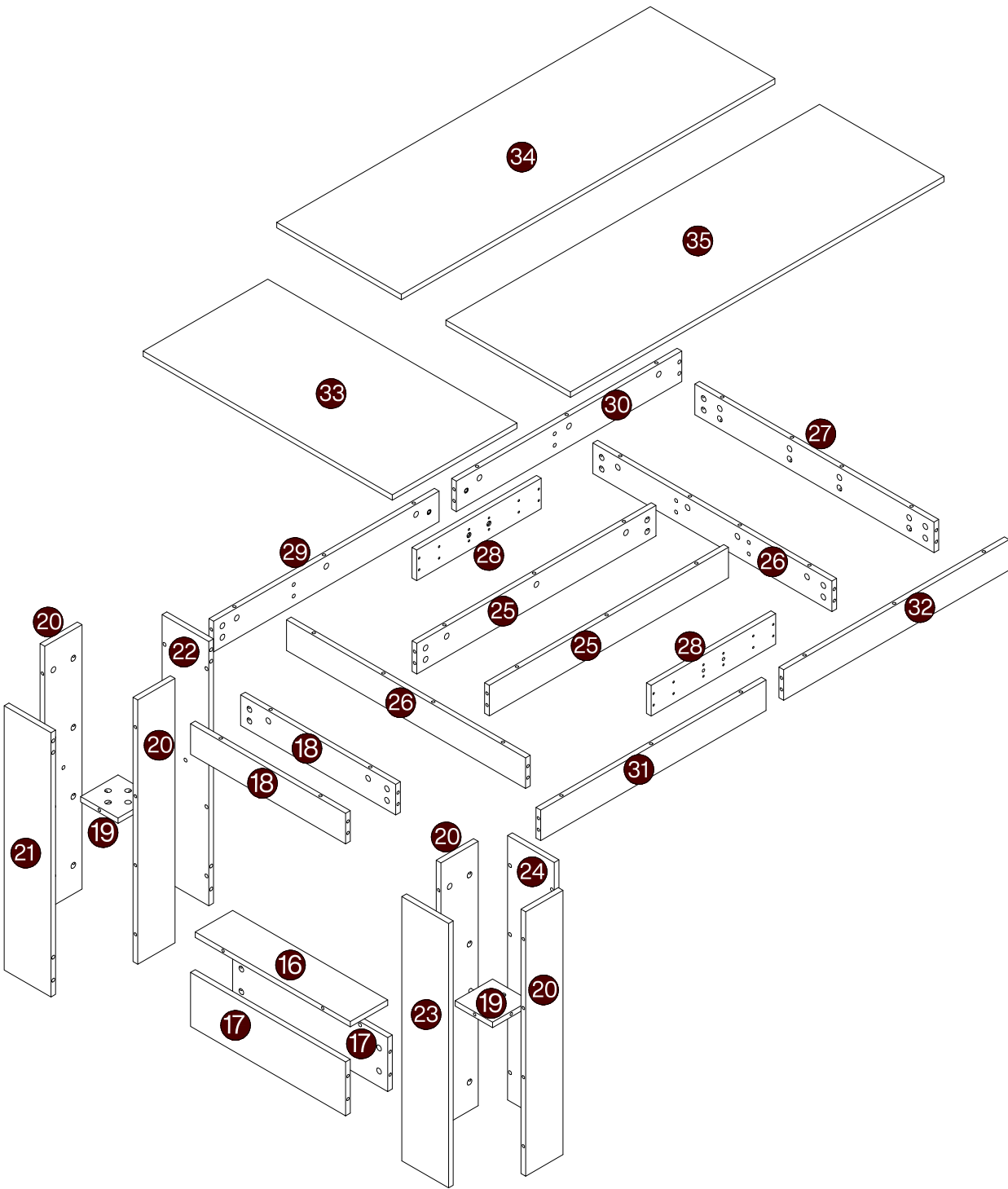

⚠ Caution

Make sure all parts are included. Most board parts are labeled or stamped on the raw edge. Contact us for a free replacement if you encounter any damaged or missing parts.

Parts List

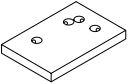
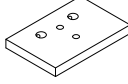
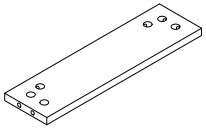
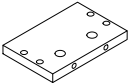
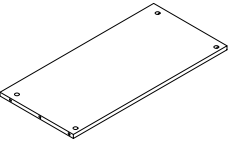
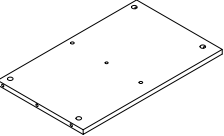
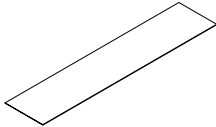
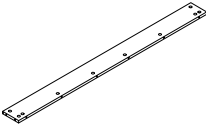
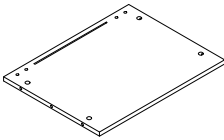
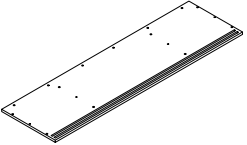
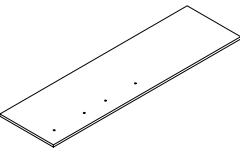
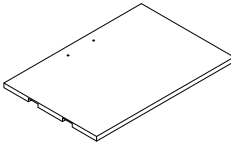
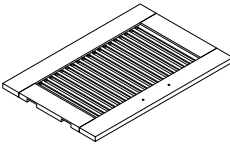
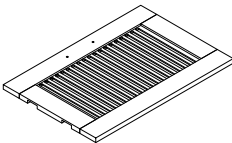
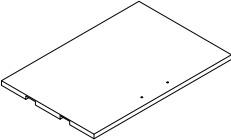
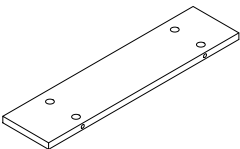
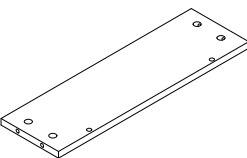
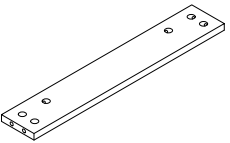
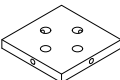
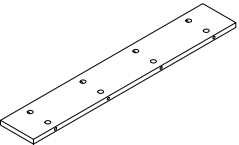
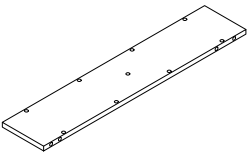
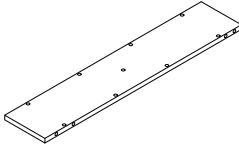
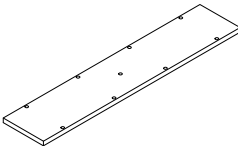
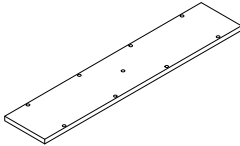
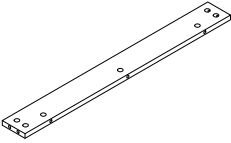

<p>1</p>  <p>2 pcs</p>	<p>2</p>  <p>2 pcs</p>	<p>3</p>  <p>4 pcs</p>	<p>4</p>  <p>4 pcs</p>	<p>5</p>  <p>1 pc</p>
<p>6</p>  <p>2 pcs</p>	<p>7</p>  <p>1 pc</p>	<p>8</p>  <p>2 pcs</p>	<p>9</p>  <p>2 pcs</p>	<p>10</p>  <p>1 pc</p>
<p>11</p>  <p>1 pc</p>	<p>12</p>  <p>1pc</p>	<p>13</p>  <p>1pc</p>	<p>14</p>  <p>1pc</p>	<p>15</p>  <p>1pc</p>
<p>16</p>  <p>1 pc</p>	<p>17</p>  <p>2 pcs</p>	<p>18</p>  <p>2 pcs</p>	<p>19</p>  <p>2 pcs</p>	<p>20</p>  <p>4 pcs</p>
<p>21</p>  <p>1 pc</p>	<p>22</p>  <p>1 pc</p>	<p>23</p>  <p>1 pc</p>	<p>24</p>  <p>1 pc</p>	<p>25</p>  <p>2 pcs</p>

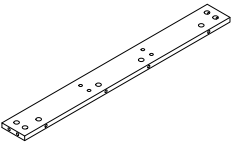
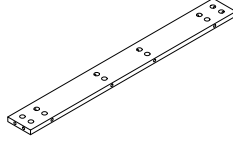
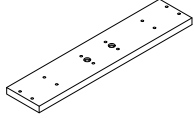
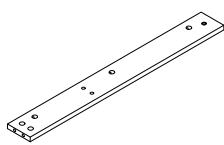
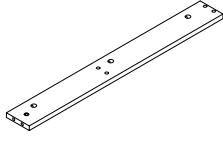
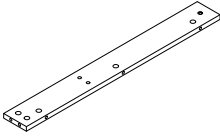
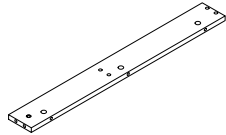
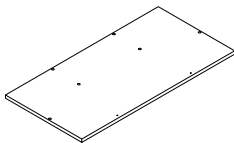
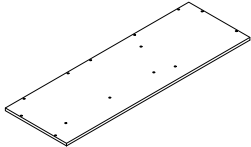
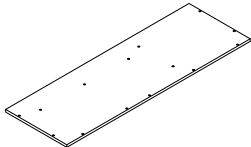

Parts List

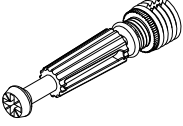
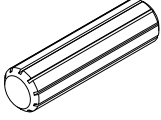
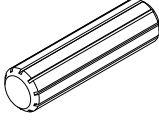
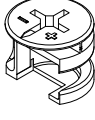
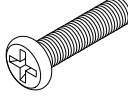
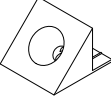
<p>26</p>  <p>2 pcs</p>	<p>27</p>  <p>1 pcs</p>	<p>28</p>  <p>2 pcs</p>	<p>29</p>  <p>1 pc</p>	<p>30</p>  <p>1 pc</p>
<p>31</p>  <p>1 pc</p>	<p>32</p>  <p>1 pc</p>	<p>33</p>  <p>1 pc</p>	<p>34</p>  <p>1 pc</p>	<p>35</p>  <p>1 pc</p>

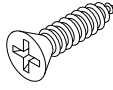
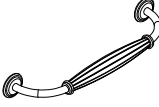
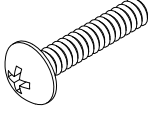
Hardware List

A	B	D	E	F	G
					
M6x40mm	Ø8x30mm	Ø8x40mm	Ø15x12mm	M6x20mm	
206 pcs	10 pcs	4 pcs	206 pcs	4 pcs	10 pcs

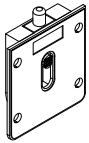
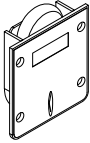
H	I	J	K	L	M
					
Ø3.5x14mm	Ø3.5x30mm	96mm	M4x18mm		
82 pcs	24 pcs	4 pcs	8 pcs	20 pcs	1 pc

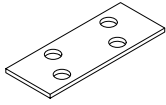
N		O	P		
N1	N2				
					
8 pcs	8 pcs	2 pcs	1 pc		

Installation of Cams and Pins

Step 1-2: Align the plastic part with the mounting hole and press it in. If you can't press it in, loosen the screw counter clockwise or completely remove the screw from the plastic part and try again.
Step 3-4: After pressing the plastic part into place, use a screwdriver to tighten the screw clockwise.

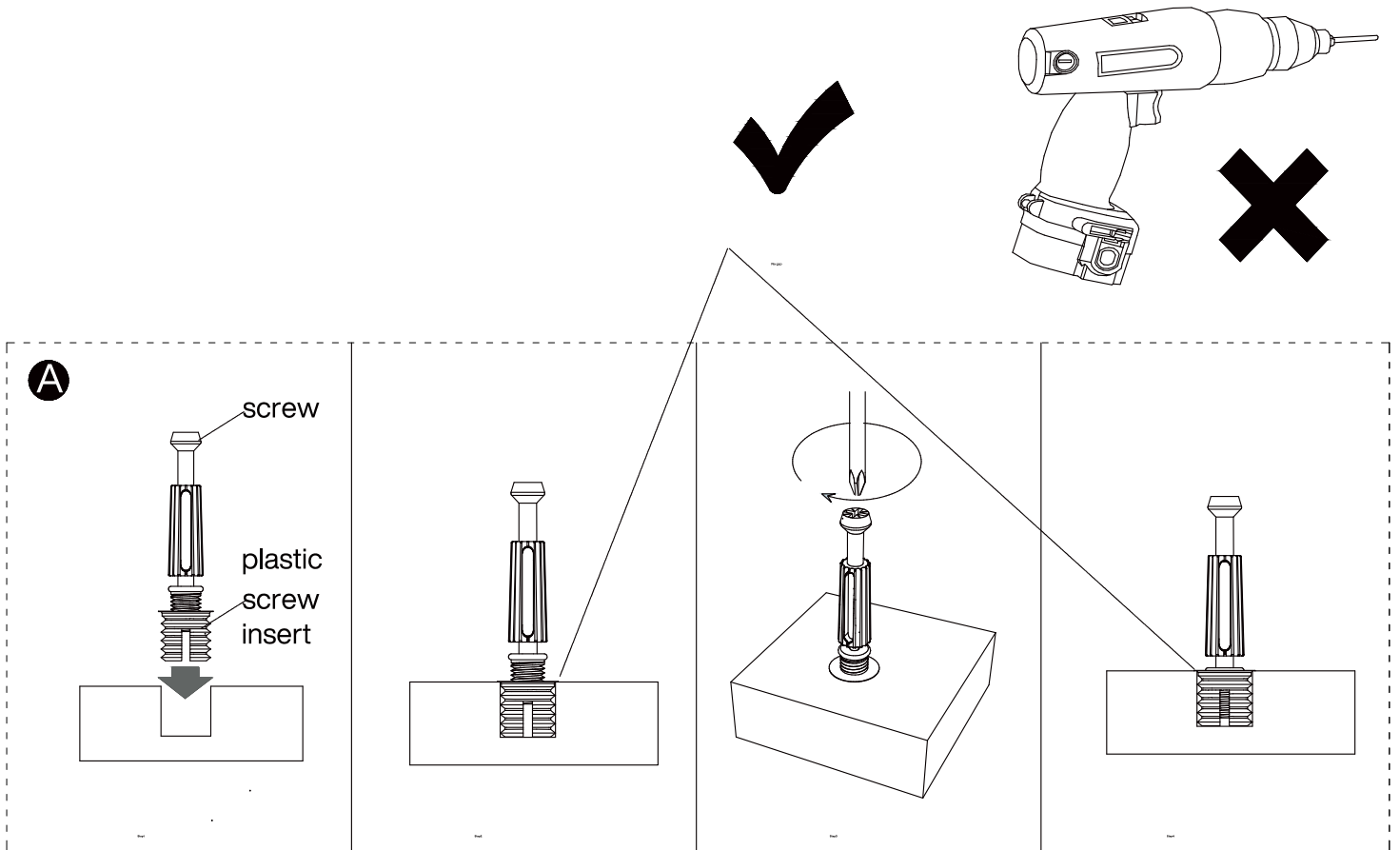

Screw the pin into the hole. Set the cams correctly by aligning the head of the cams with the lock pins. Lock the cam by turning the cam head with a screwdriver until it is tightened. Please do not use an electric screwdriver to assemble the unit.

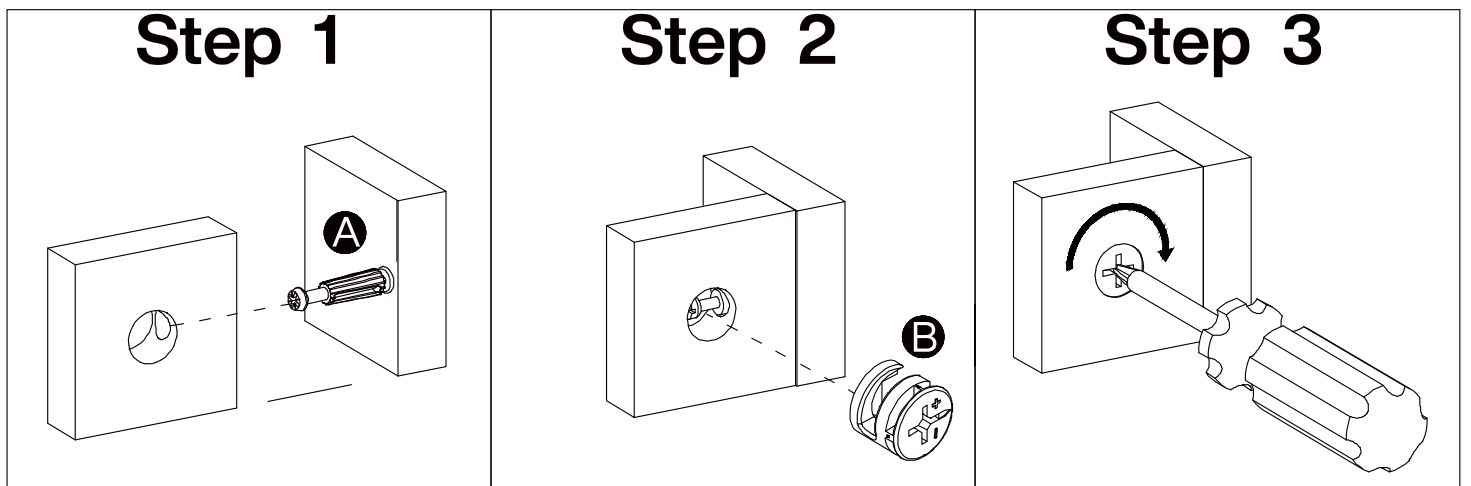

1

A

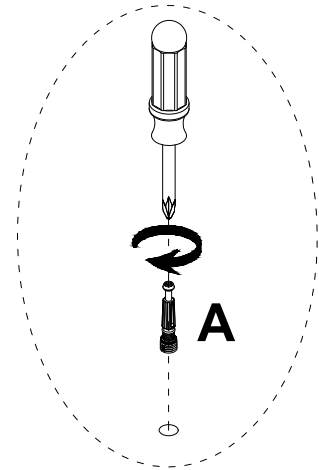
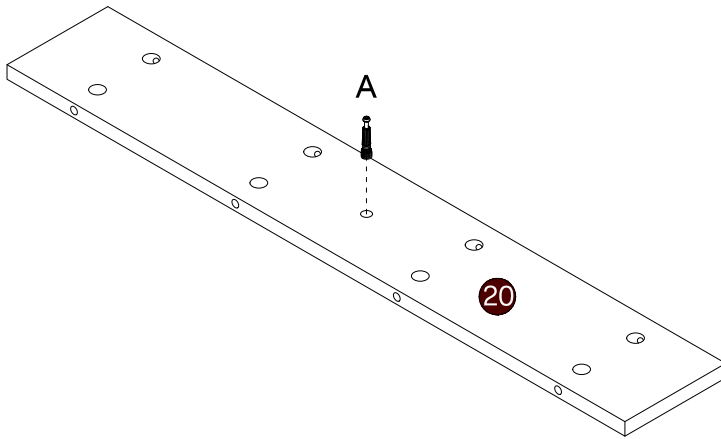
M6x35mm
4 pcs



x4

2

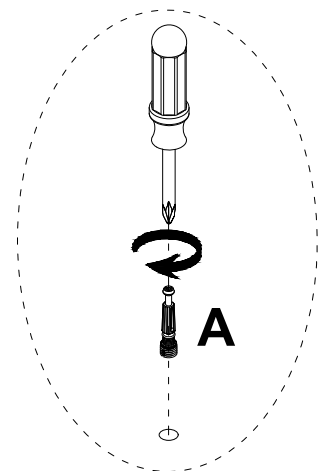
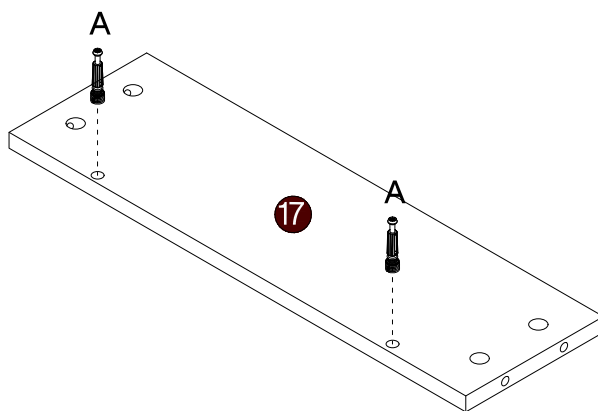
A

M6x35mm
4 pcs

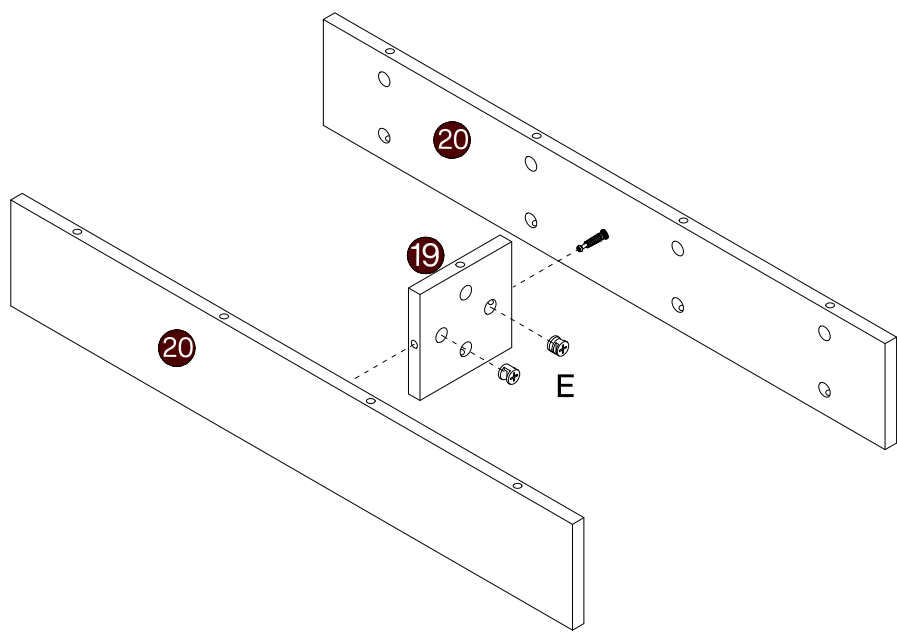
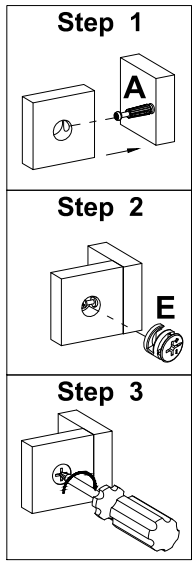

x2

3



E

Ø15x12mm
4pcs

x2

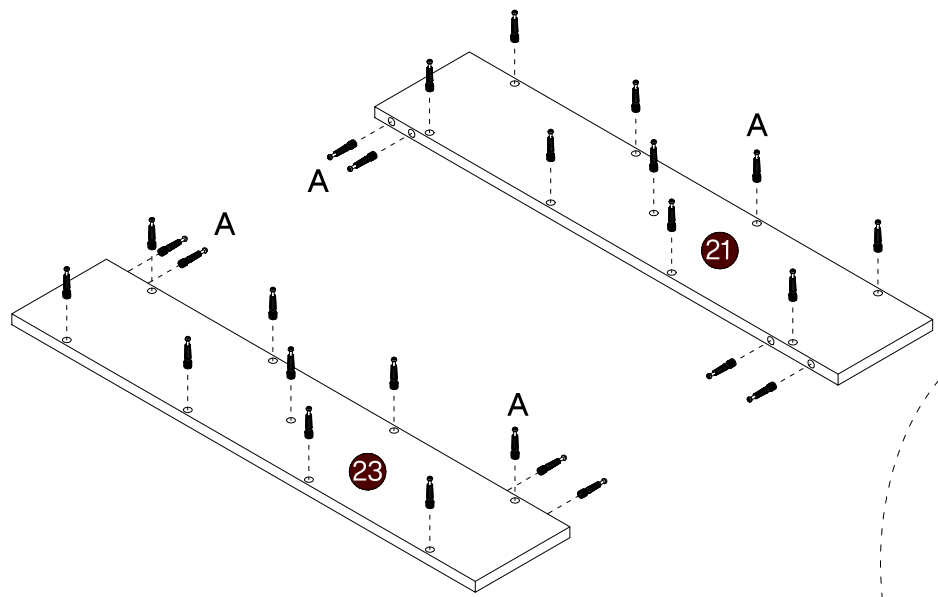
4

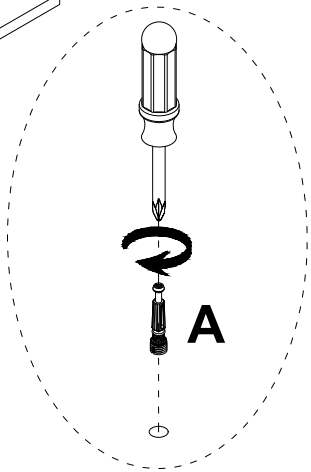

A

M6x35mm
26 pcs



5

E

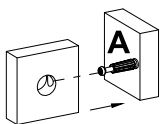
Ø15x12mm
8 pcs

Step 1

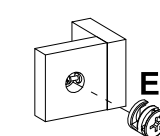

Step 2

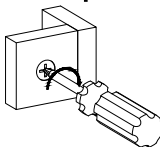
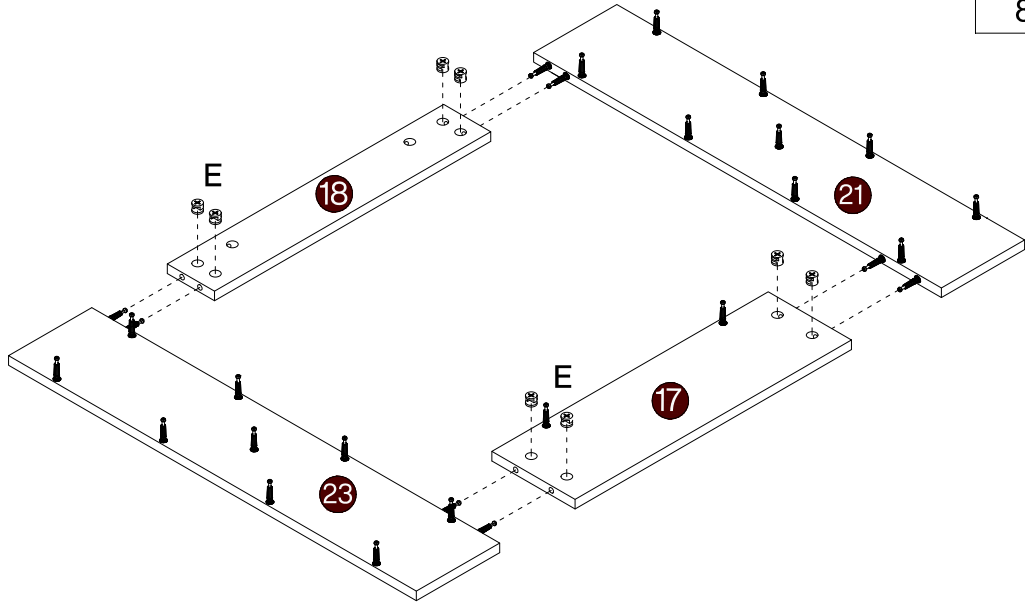

Step 3

6

E

Ø15x12mm
20 pcs

Step 1

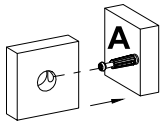

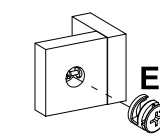
Step 2

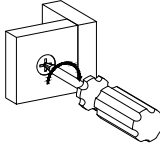
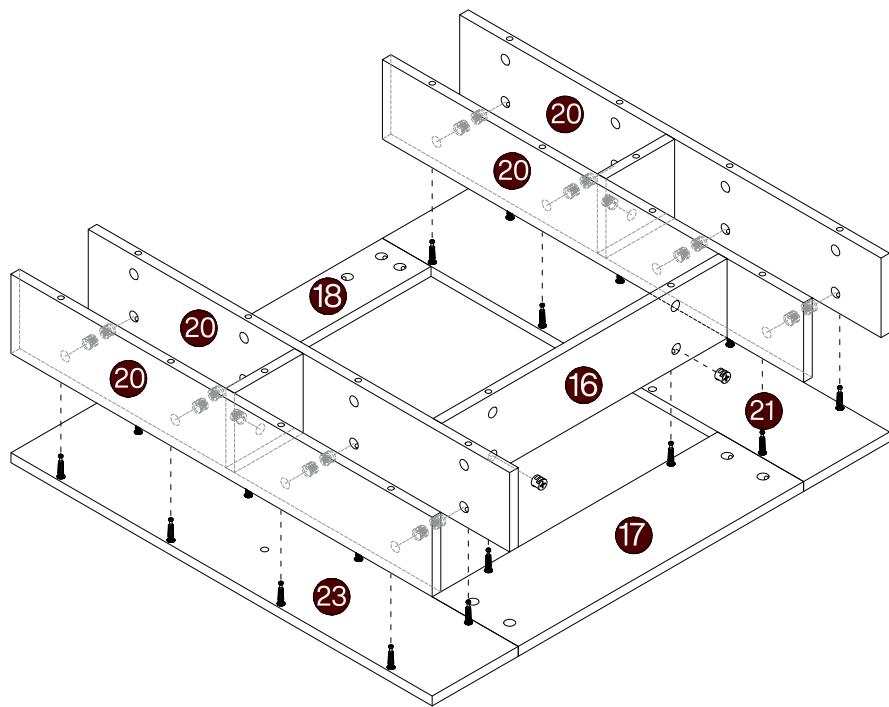

Step 3

7

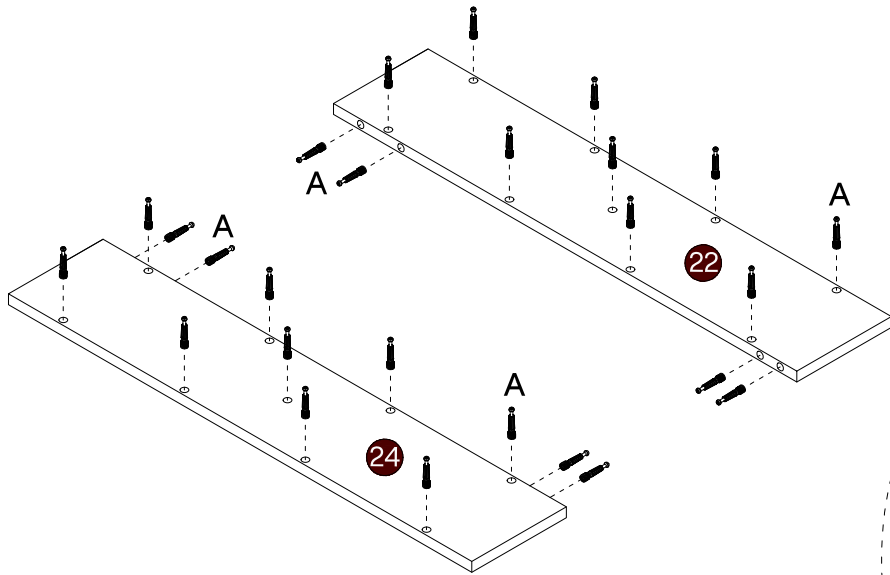

A

M6x35mm
26 pcs

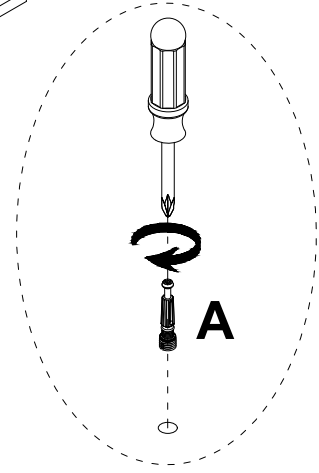

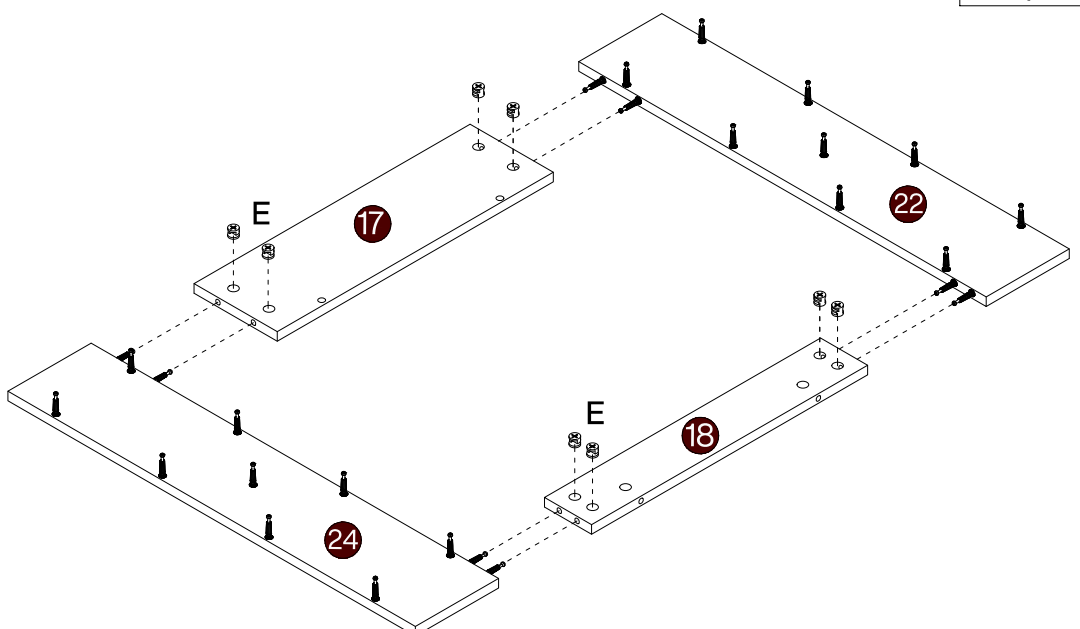
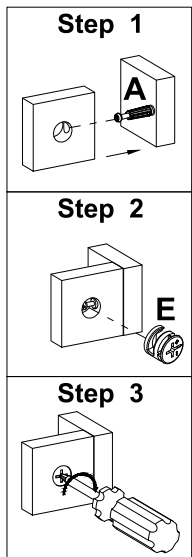
8



E

Ø15x12mm
8 pcs

9

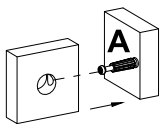
Step 1

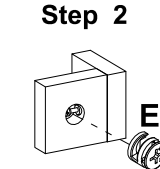

Step 2



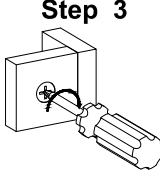
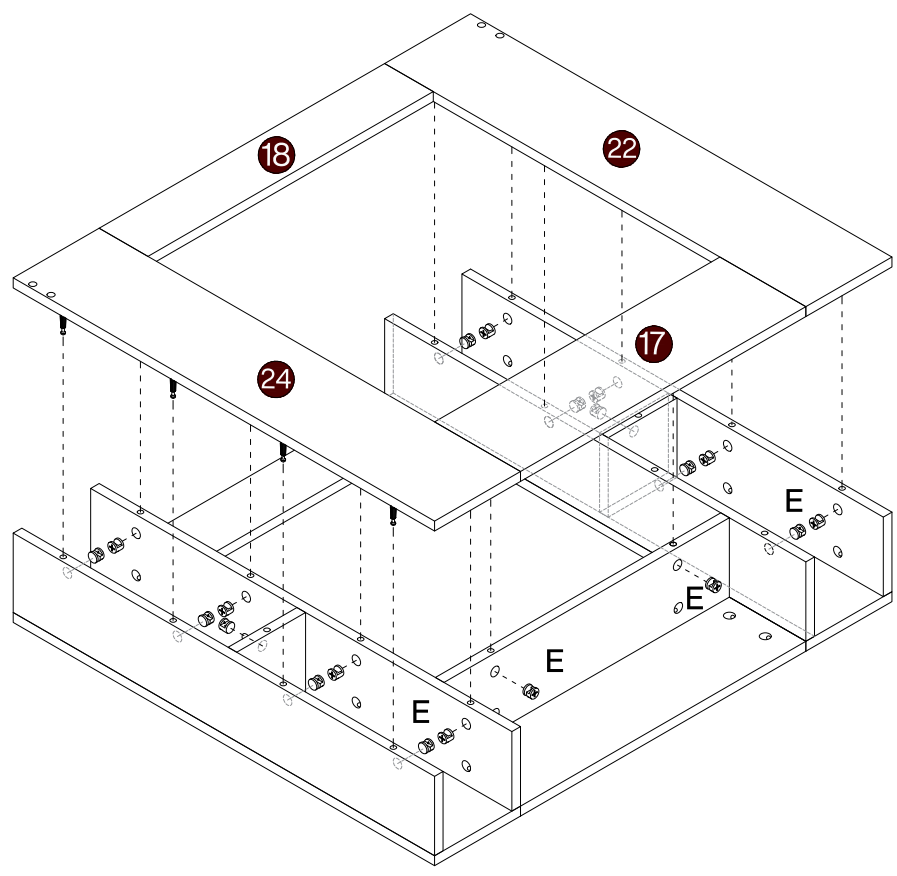

Step 3



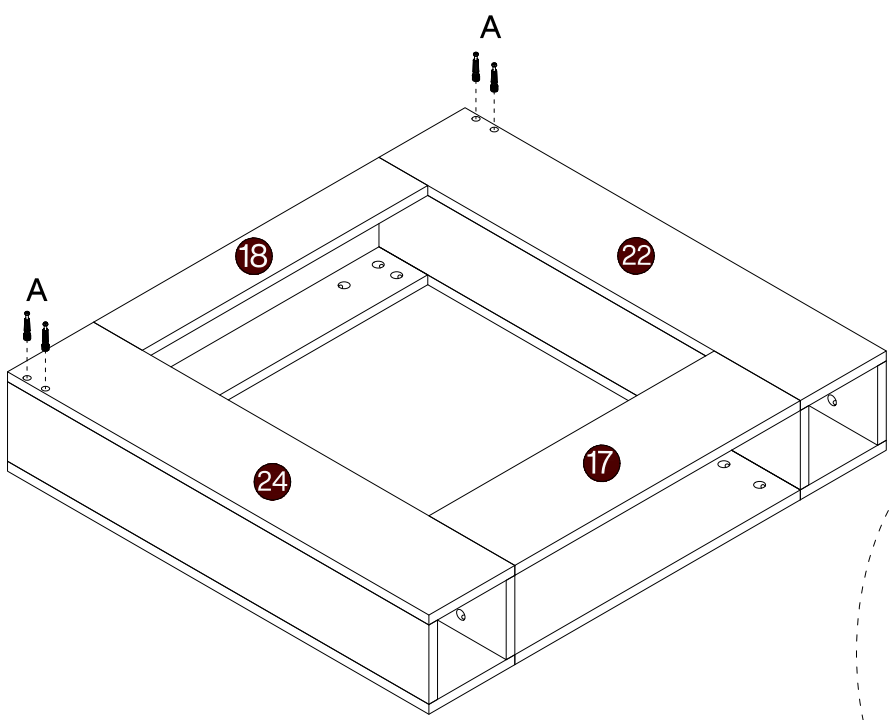

E

Ø15x12mm
20 pcs

10

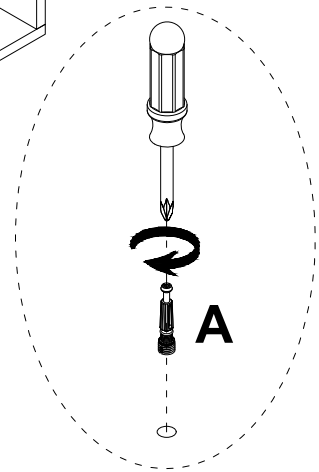

A

M6x35mm
4 pcs

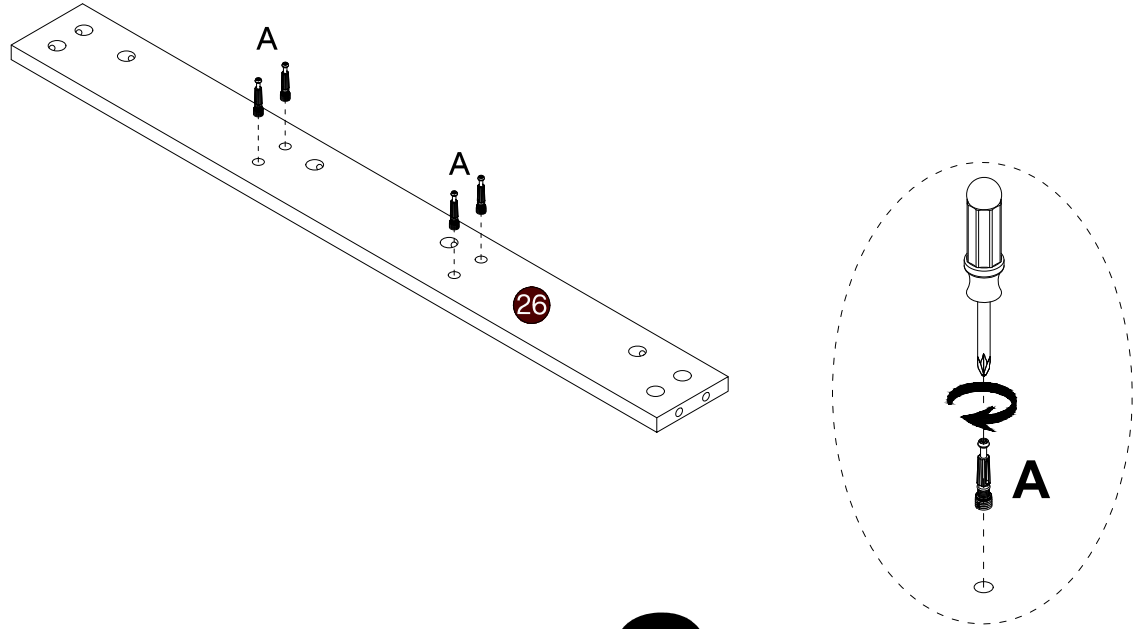

11

A

M6x35mm
8 pcs



x2

12

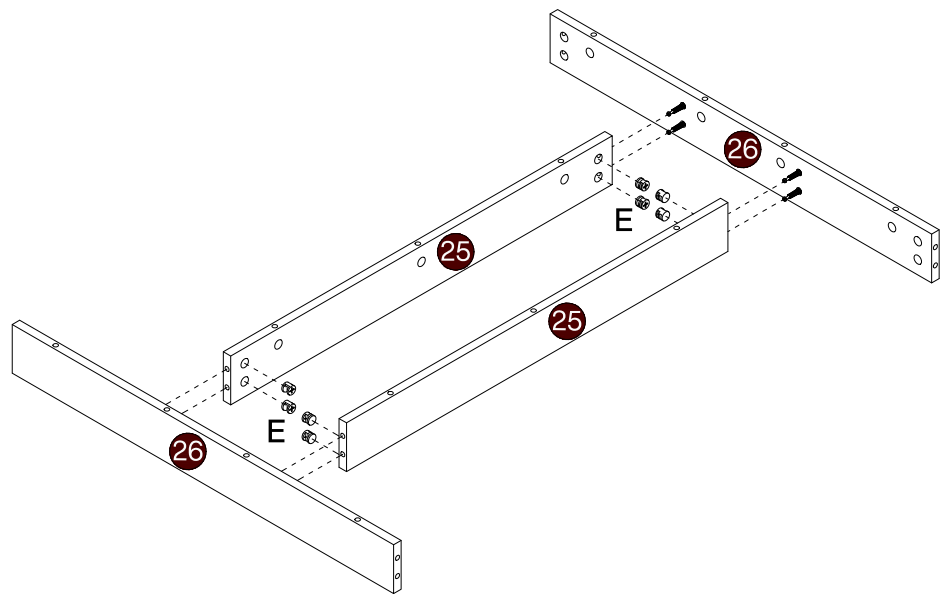
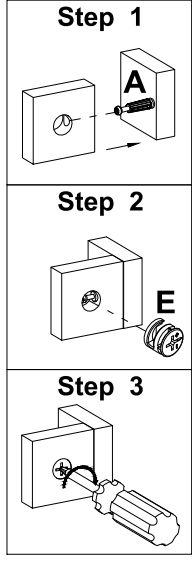
E

Ø15x12mm
8 pcs



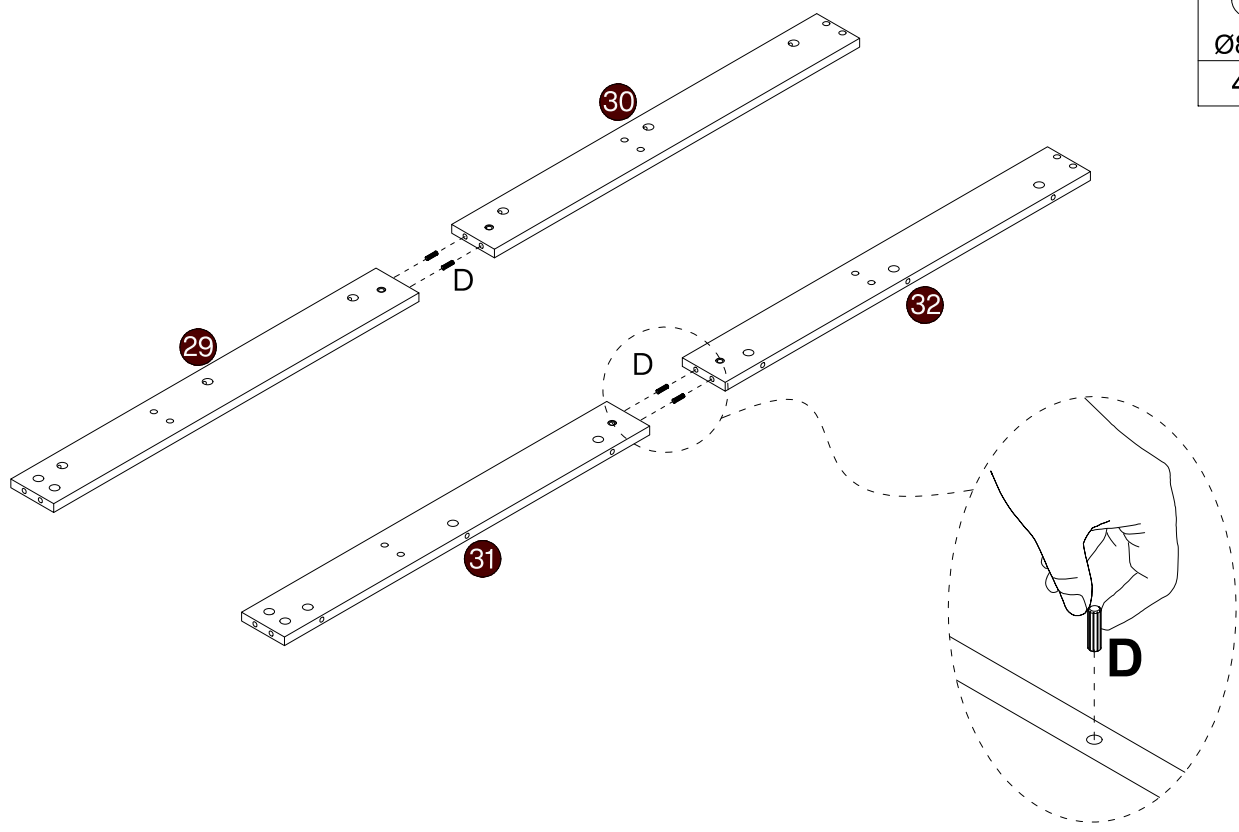

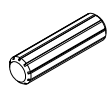
13

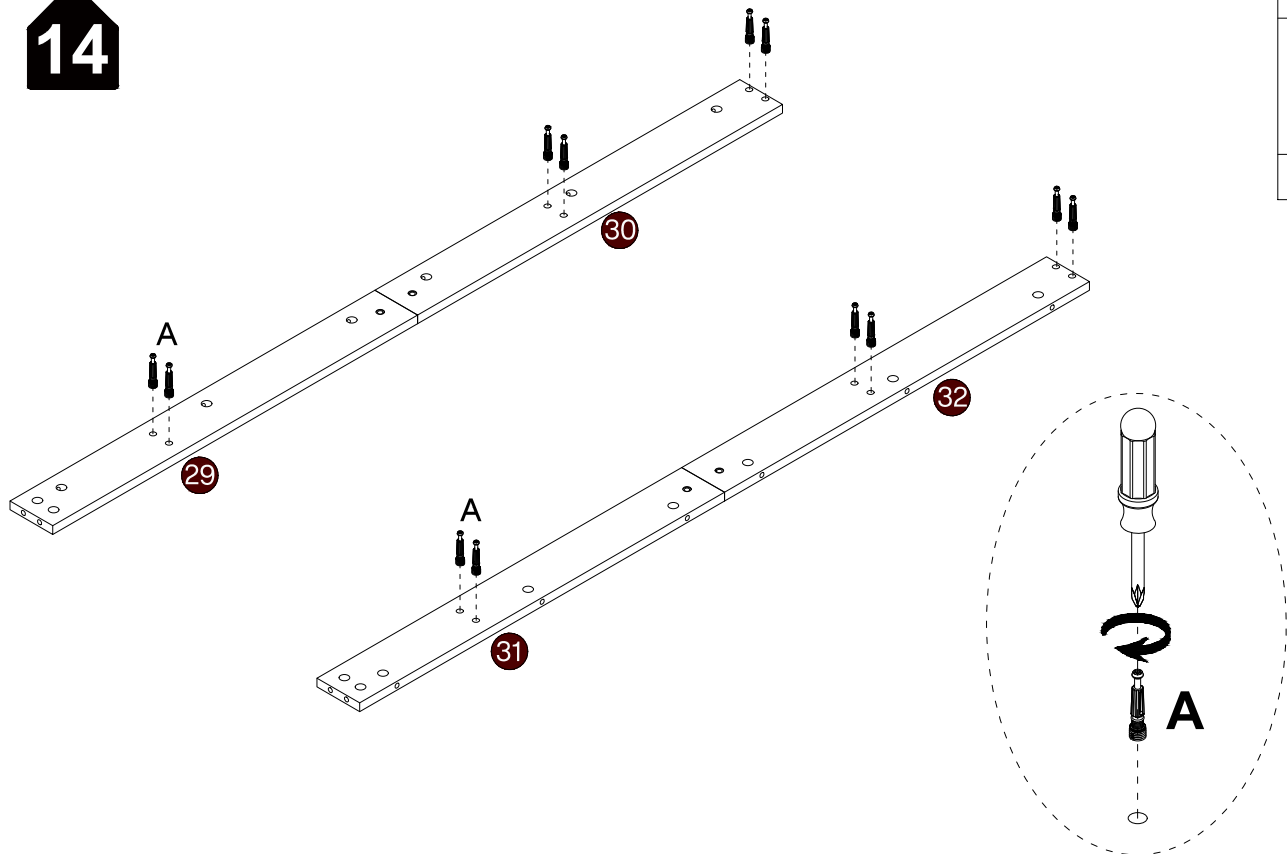

D

Ø8x40mm
4 pcs

14



A

M6x35mm
12 pcs

15

E

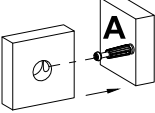
Ø15x12mm
12 pcs

Step 1



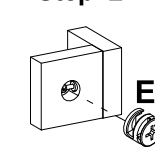

Step 2

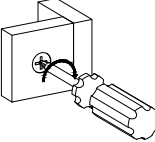
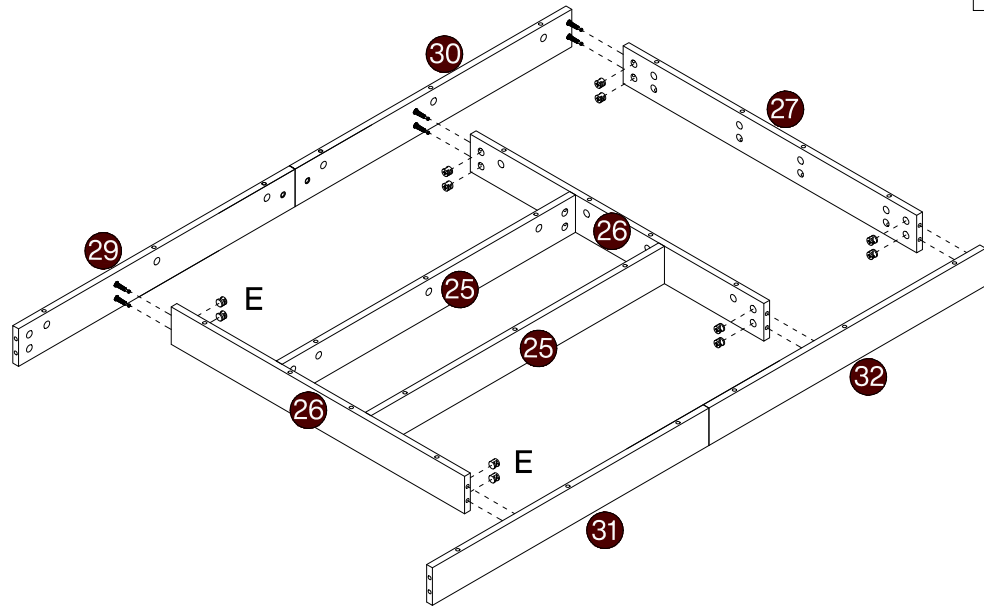

Step 3



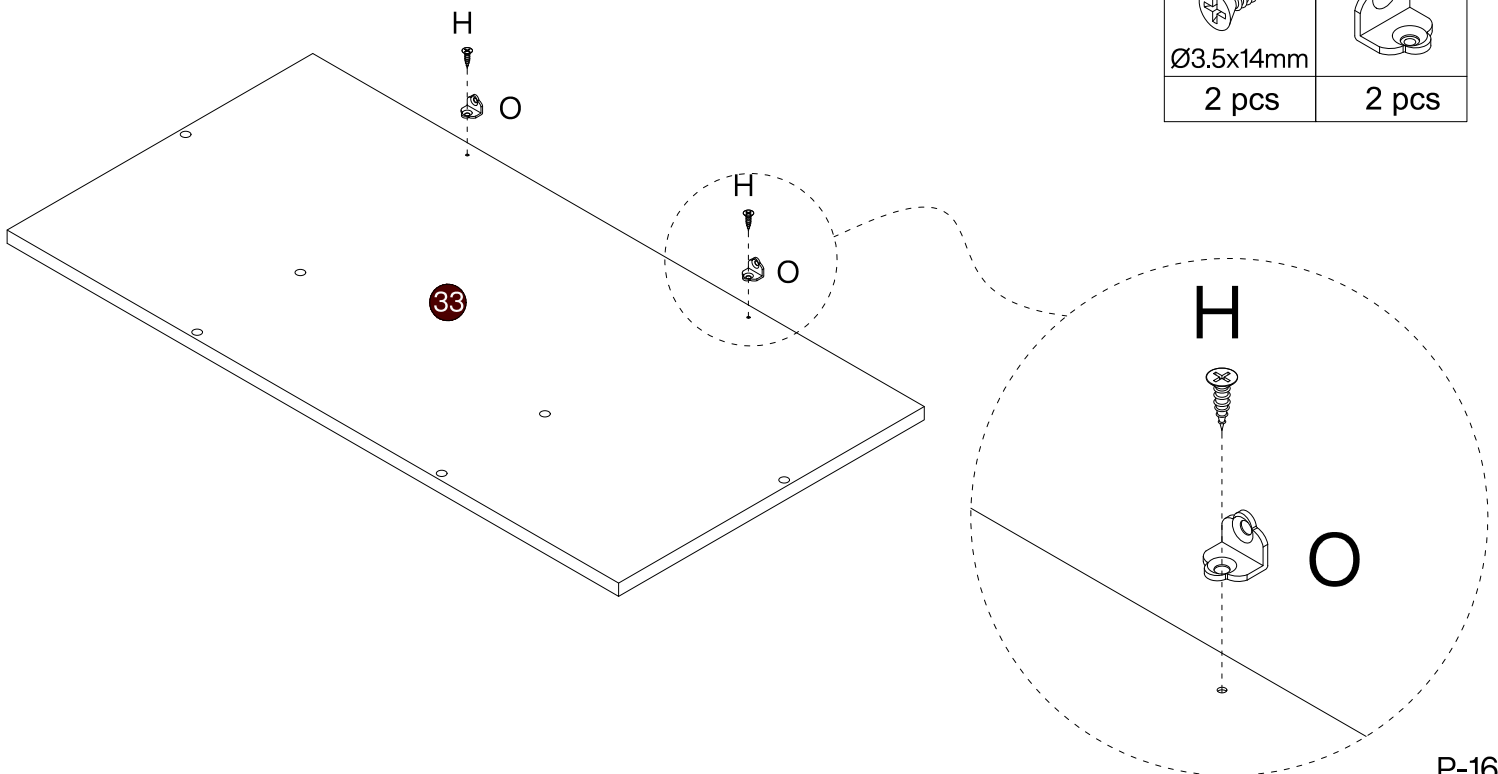

16

H	O
	
Ø3.5x14mm	
2 pcs	2 pcs



17

A

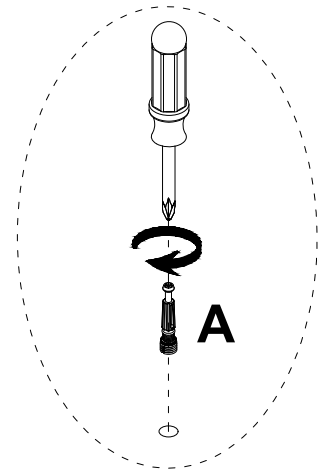
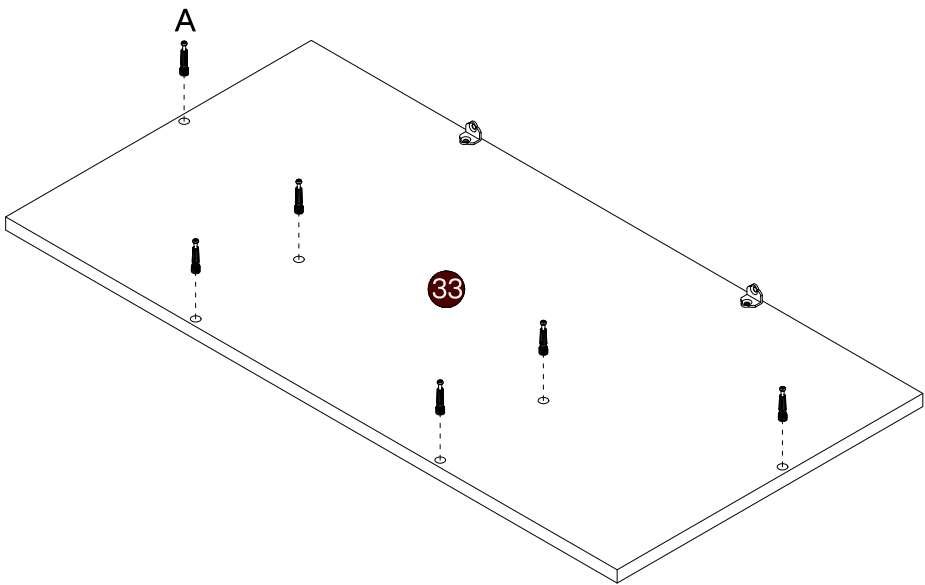
M6x35mm
6 pcs



18

A

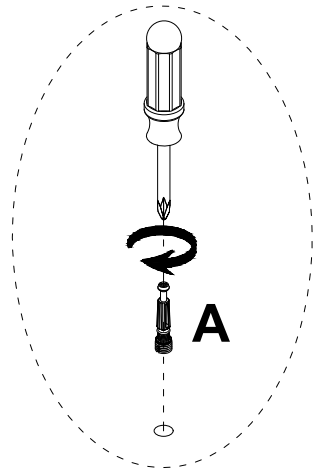
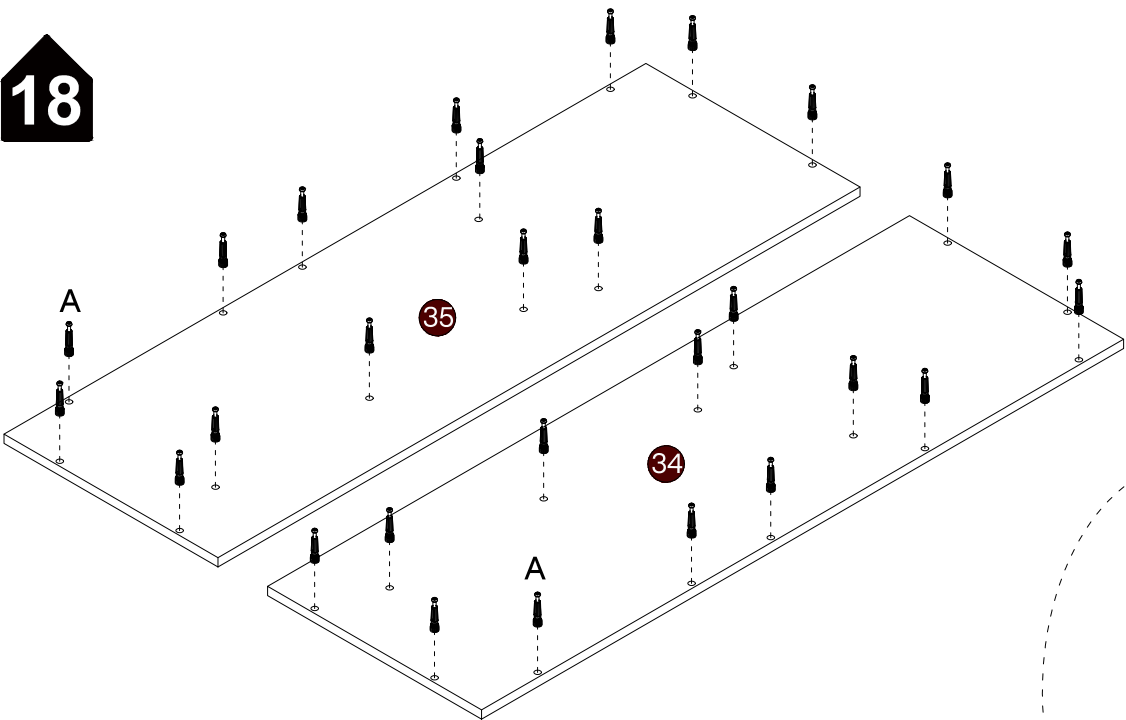
M6x35mm
28 pcs



19

Step 1

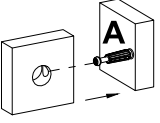

Step 2

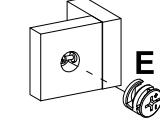

Step 3

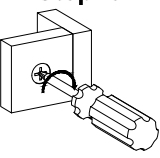
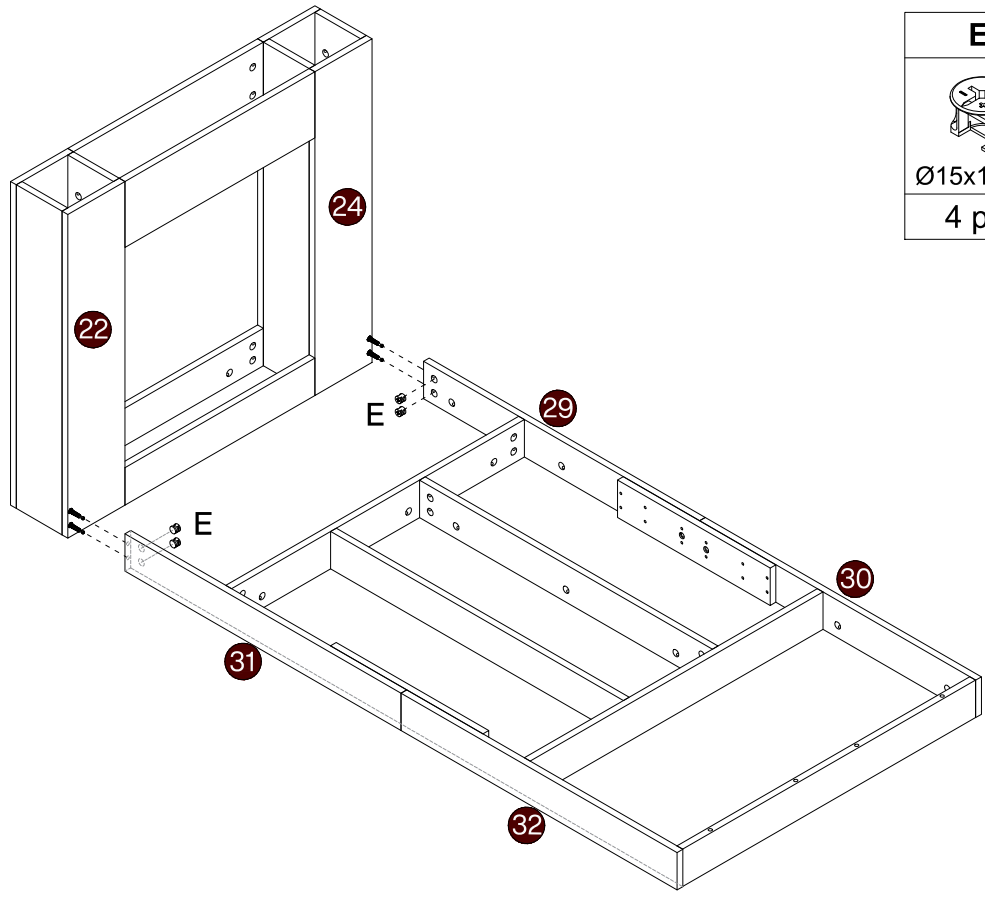
E

Ø15x12mm
4 pcs

20

Step 1

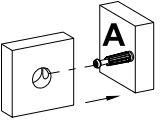

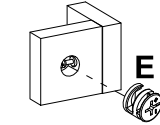
Step 2

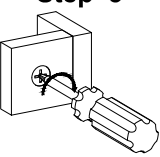
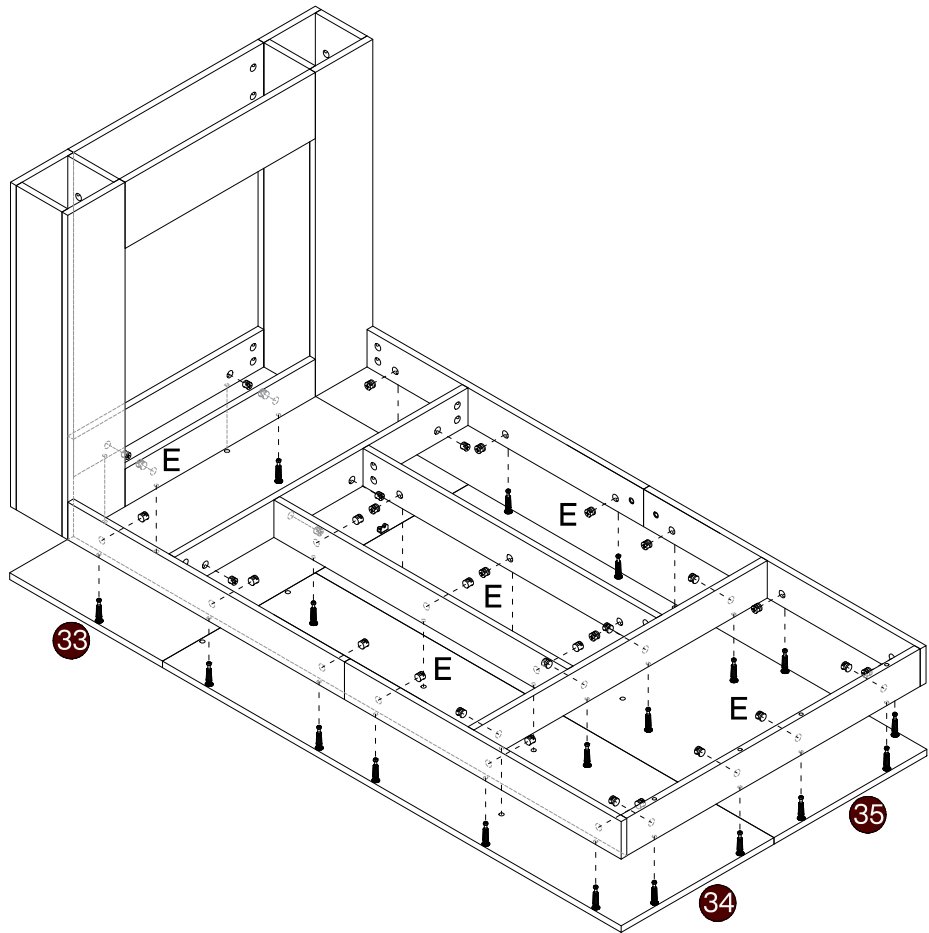

Step 3

E

Ø15x12mm
34 pcs

21

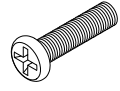
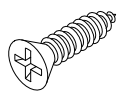
F	I
	
M6x20mm	Ø3.5x30mm
4 pcs	24 pcs

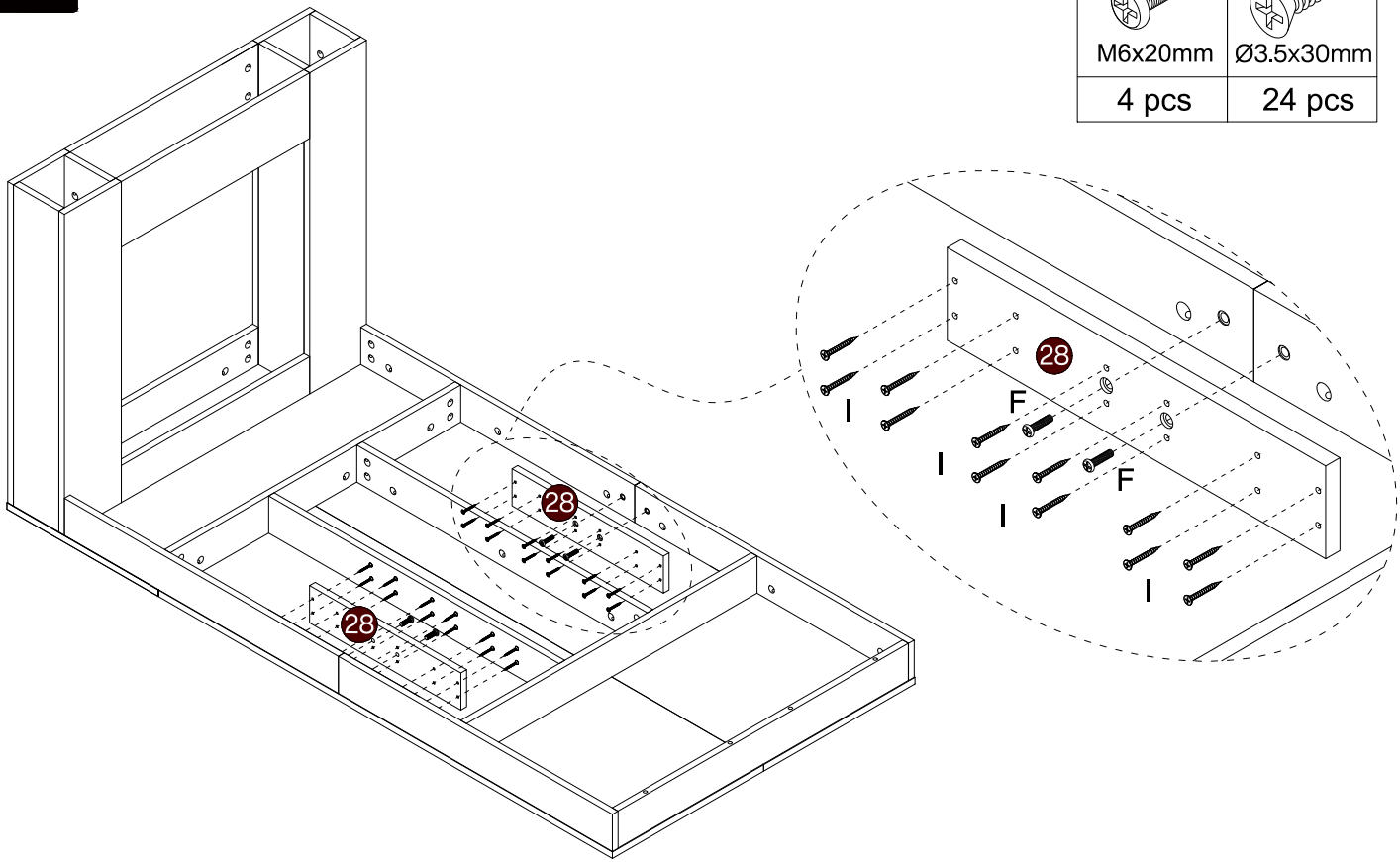

22

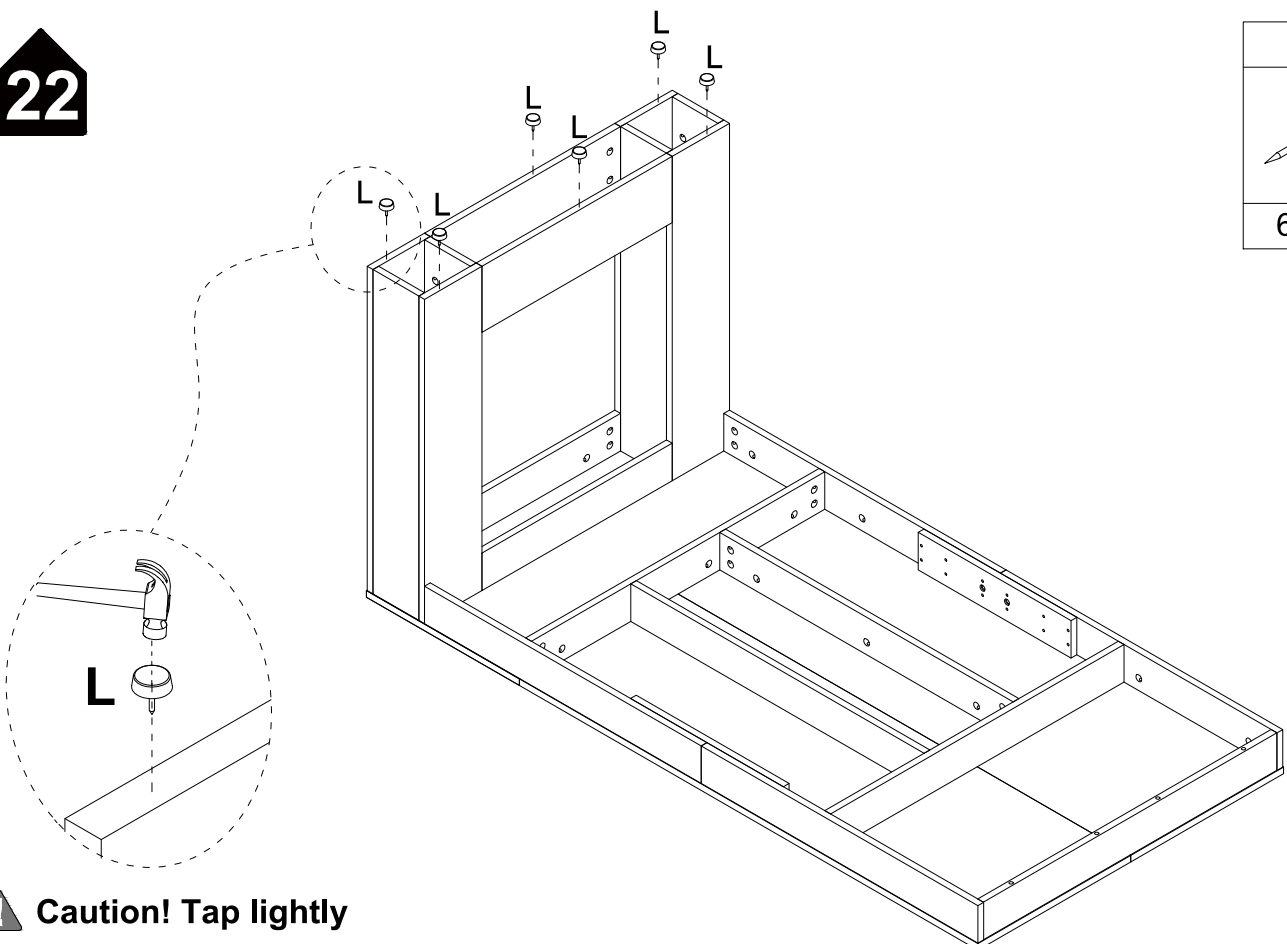

L

6 pcs

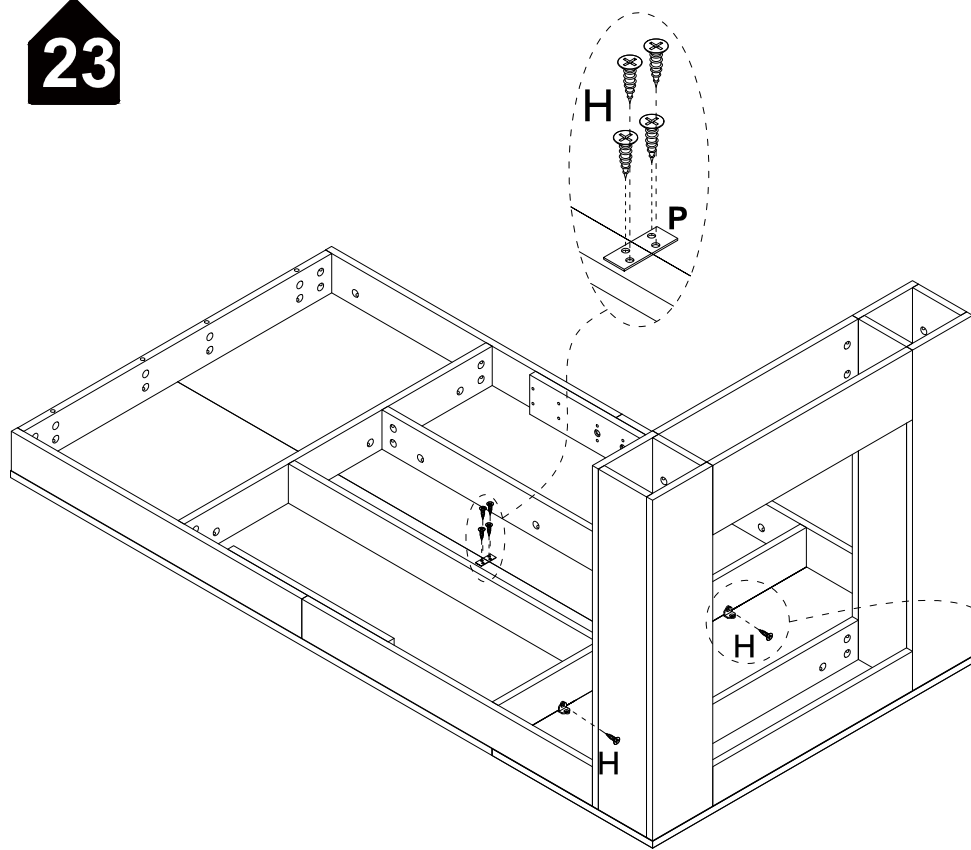

 Caution! Tap lightly

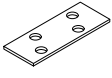
23



P	H
	 Ø3.5x14mm
1 pcs	6 pcs

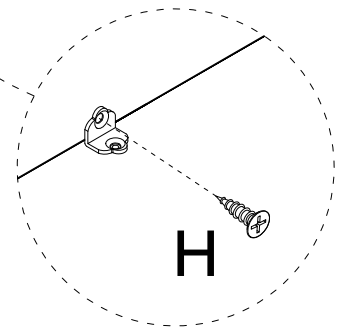

24

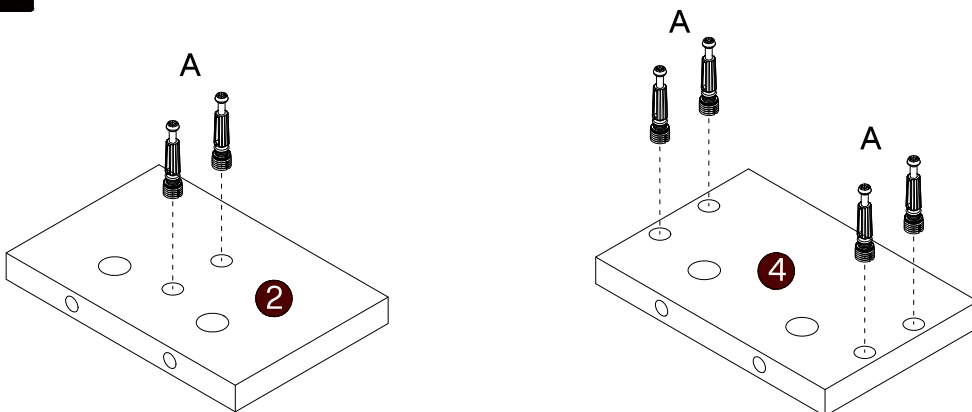

A
 M6x35mm
20 pcs

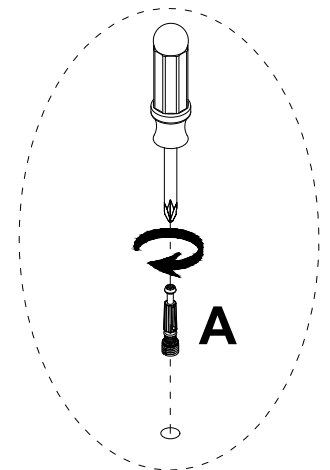

x2

x4

25

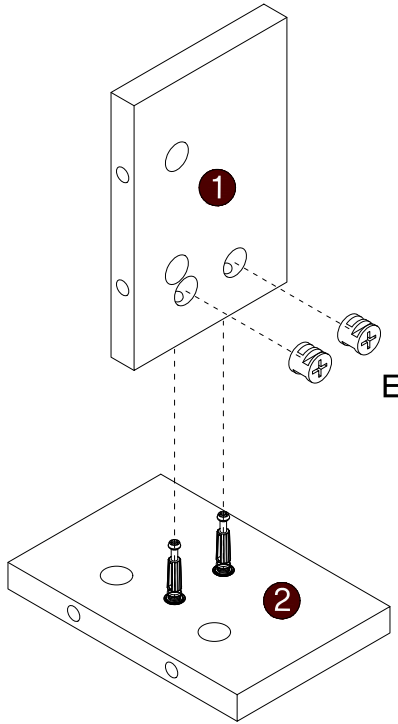
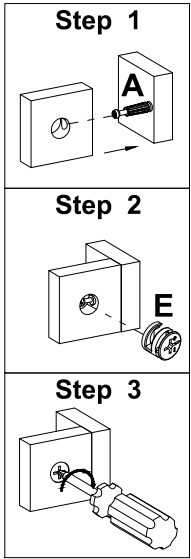

E

Ø15x12mm
4 pcs

x2

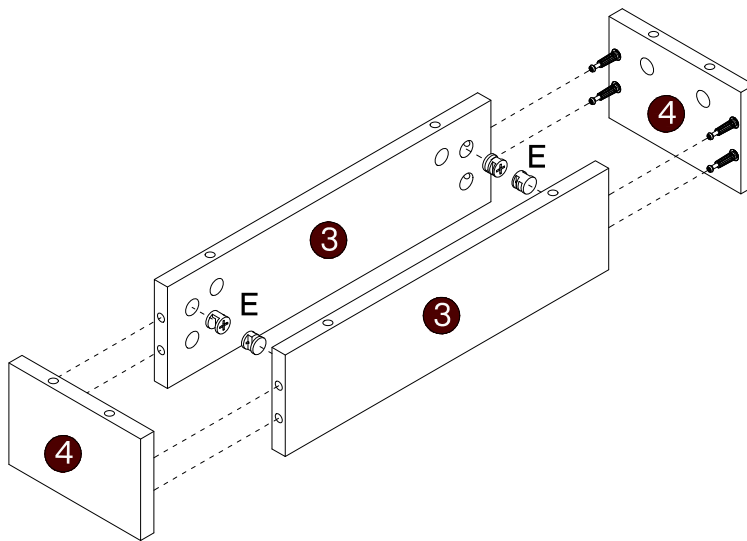
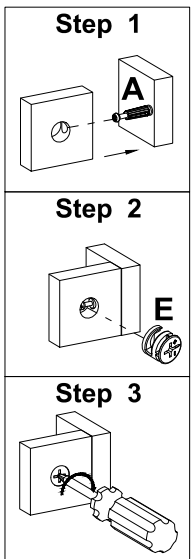
26



E

Ø15x12mm
8 pcs

x2

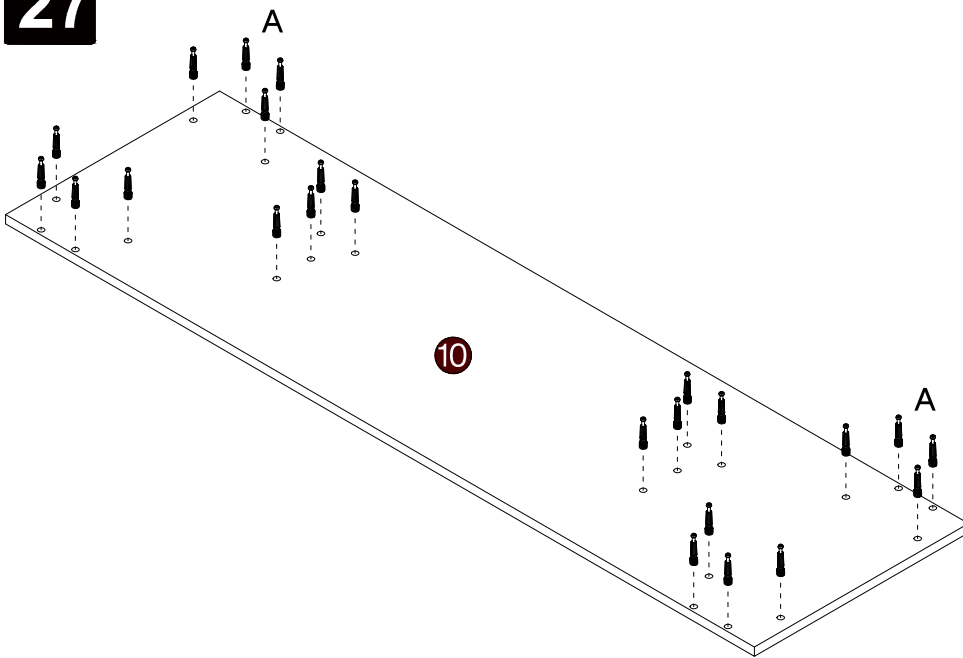
27

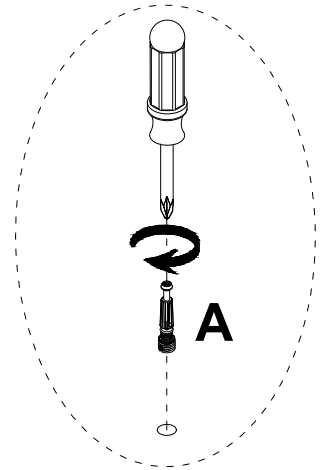

A

M6x35mm
24 pcs

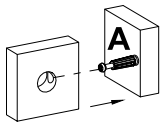

28

Step 1



Step 2

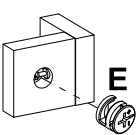

Step 3

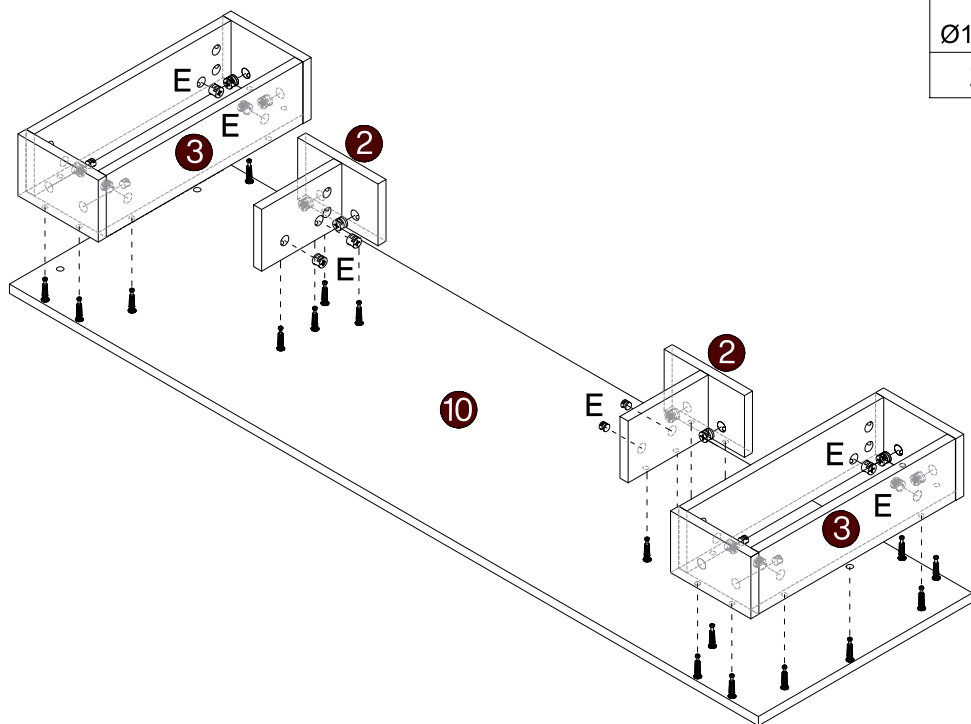
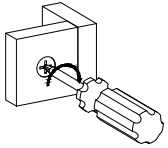

E

Ø15x12mm
24 pcs

29

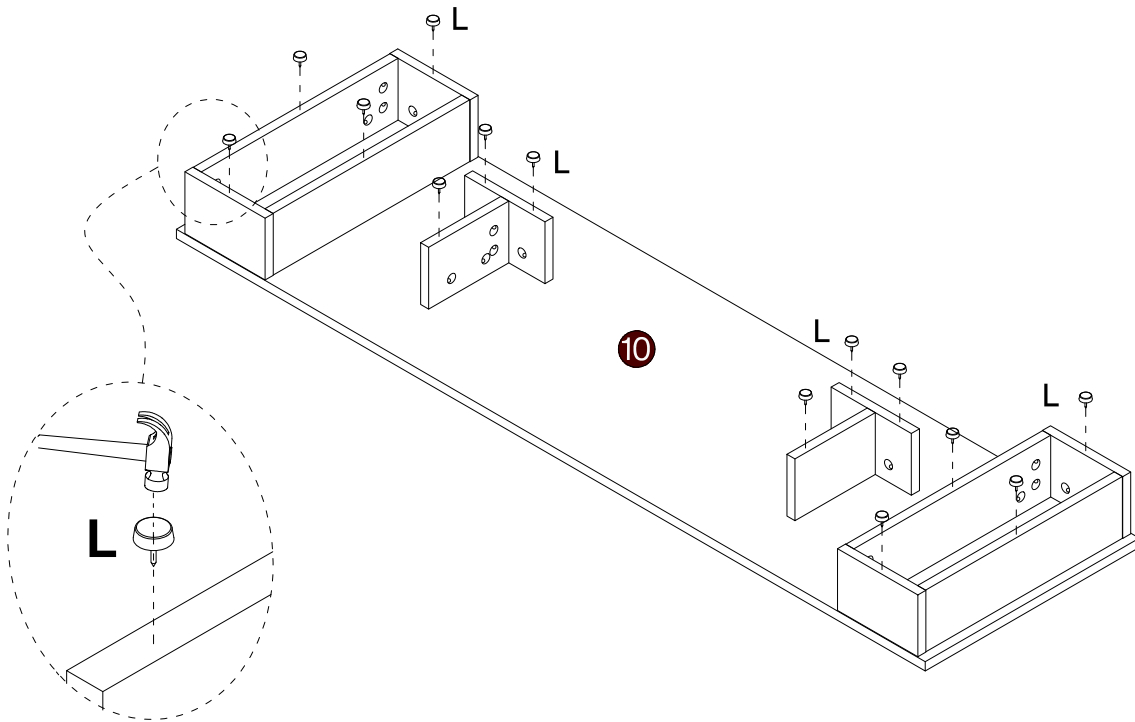
L

14 pcs

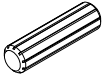

! Caution! Tap lightly

30

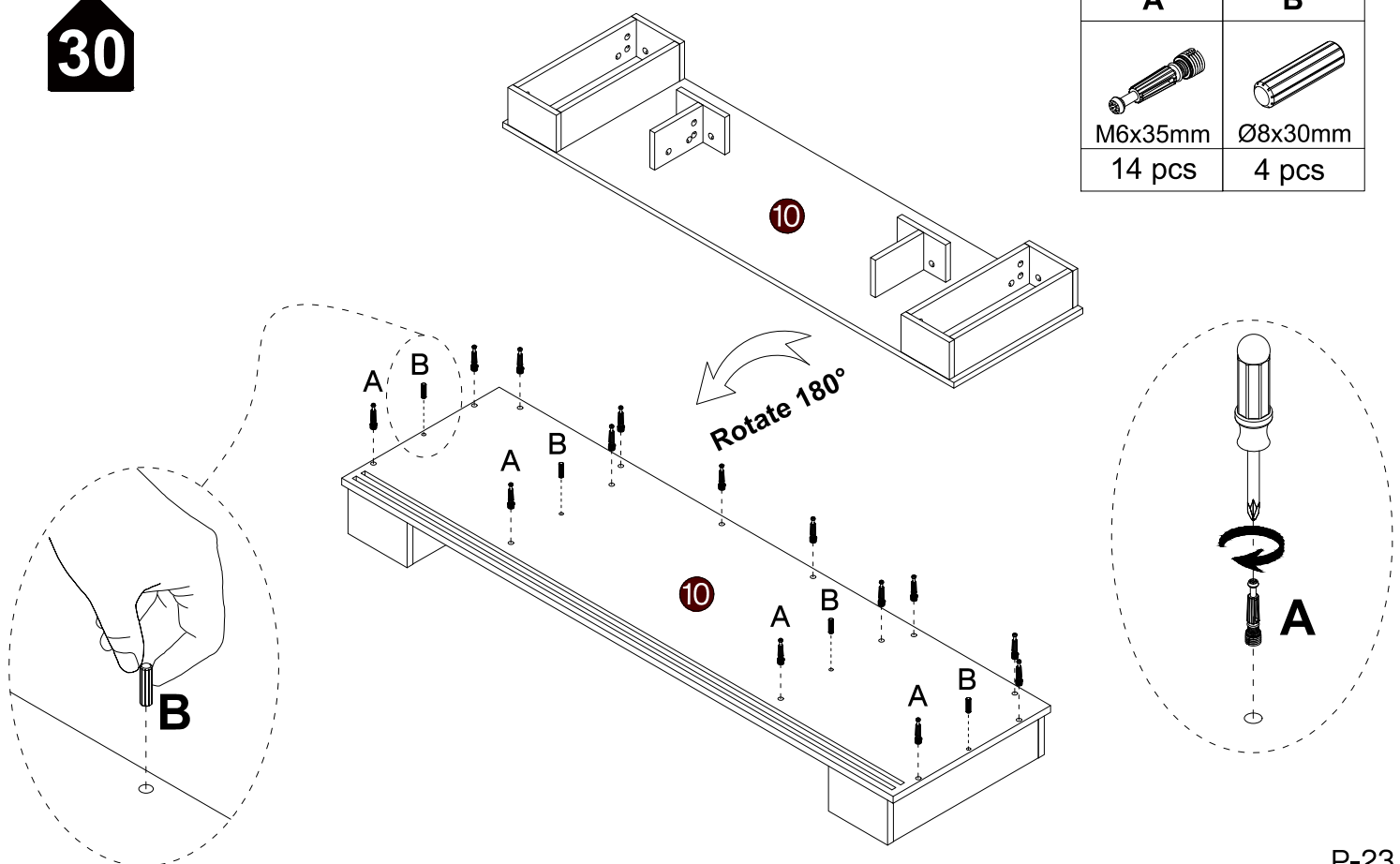
A	B
	
M6x35mm	Ø8x30mm
14 pcs	4 pcs



31

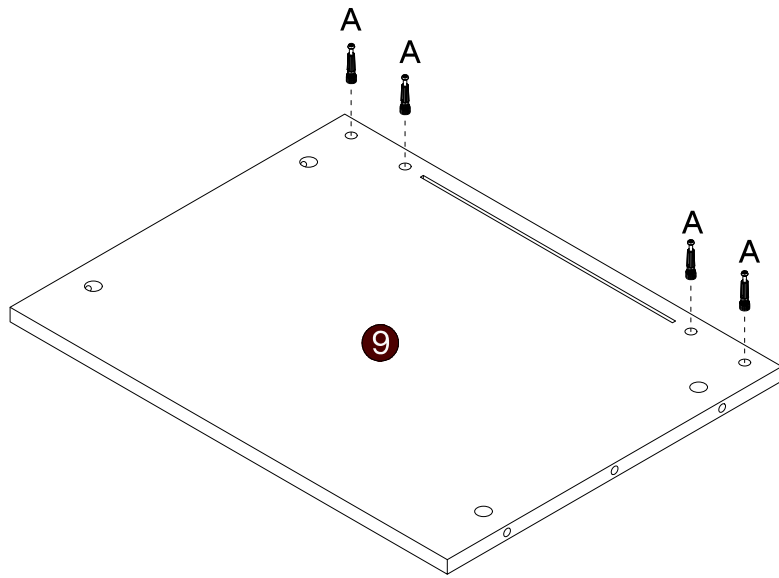

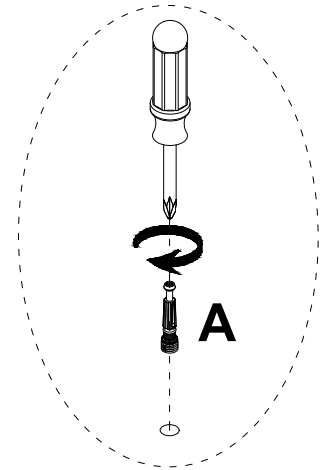

A

M6x35mm
8 pcs

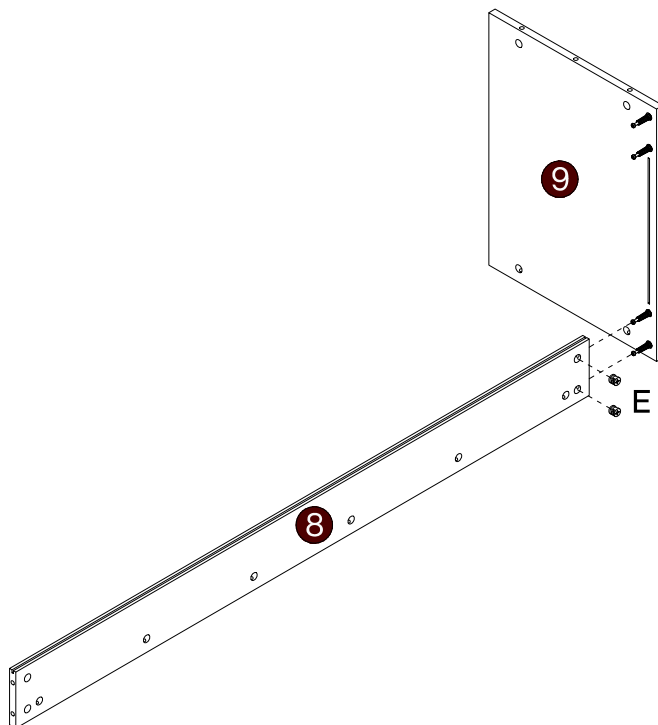
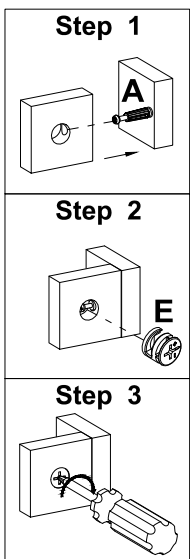

x2

32



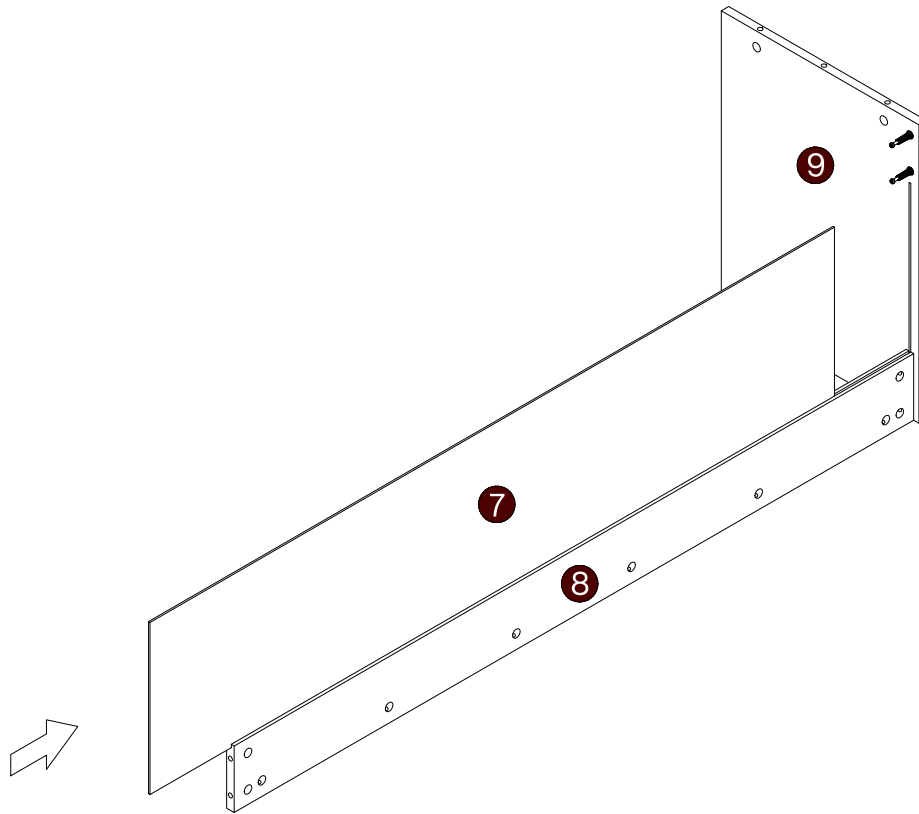

E

Ø15x12mm
2 pcs

33

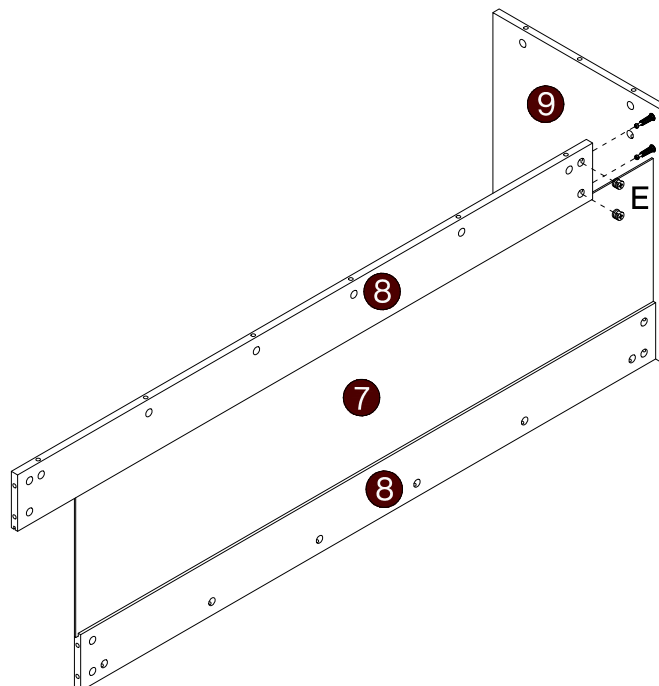
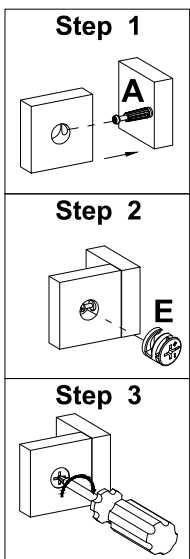

34



E

Ø15x12mm
2 pcs

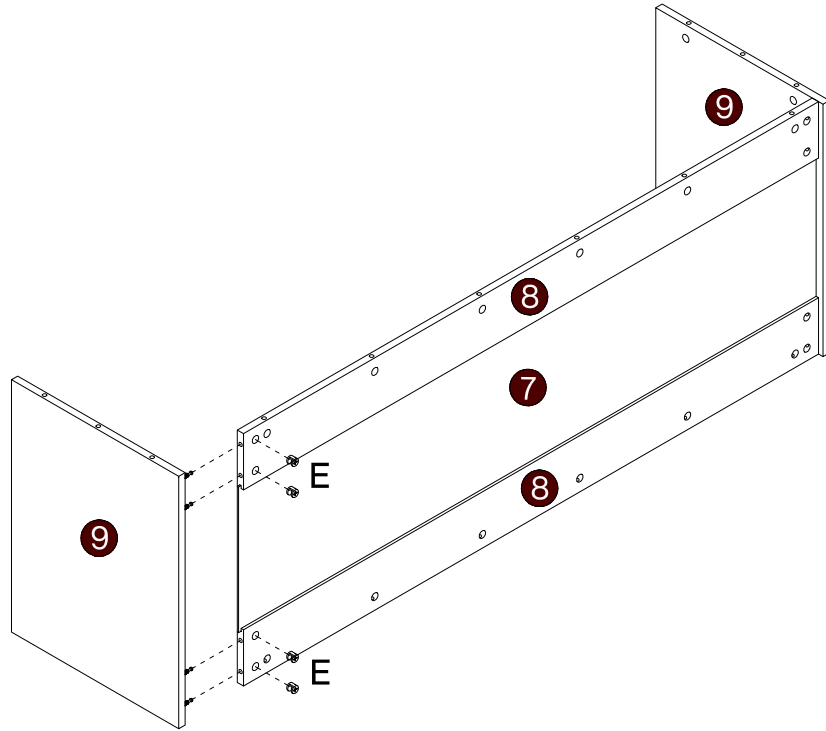
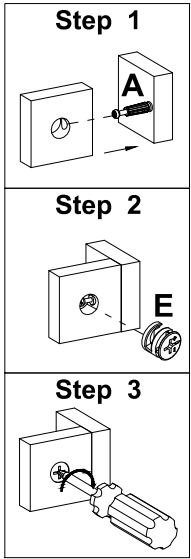
35

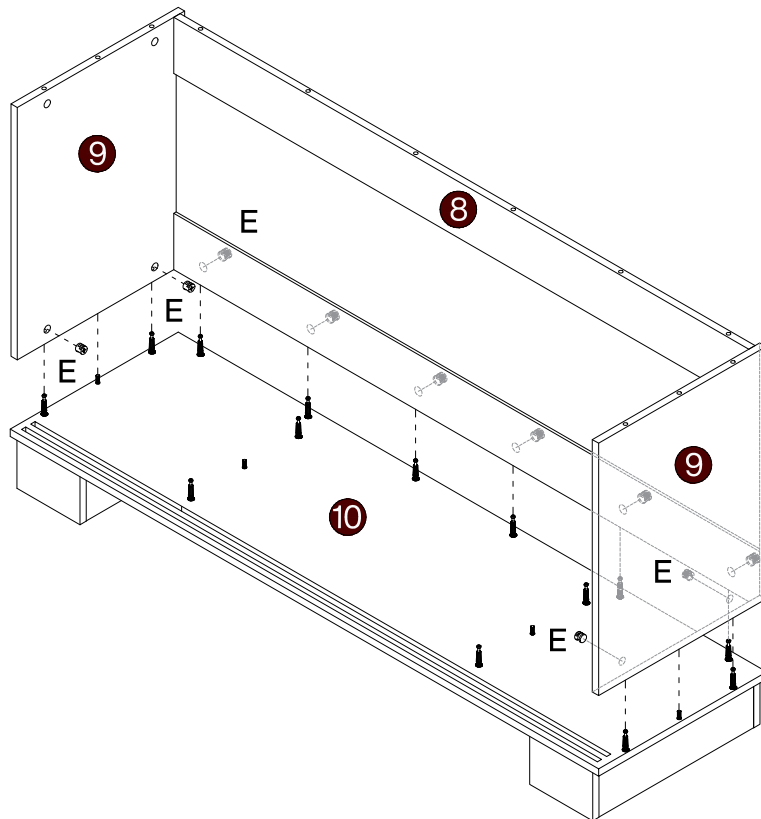
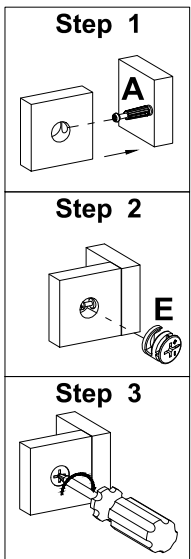

E
Ø15x12mm
4 pcs

36



E
Ø15x12mm
10 pcs

37

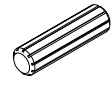
A	B
	
M6x35mm	Ø8x30mm
4 pcs	2 pcs

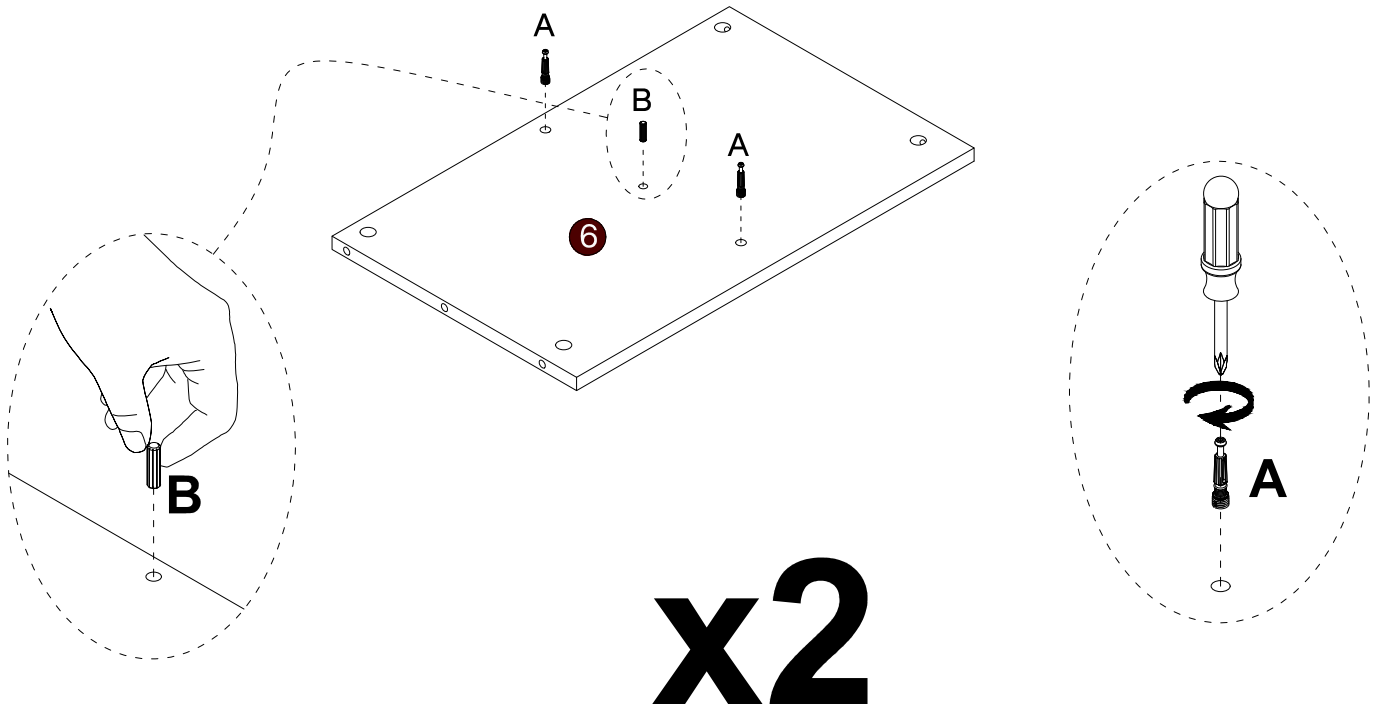

38

E

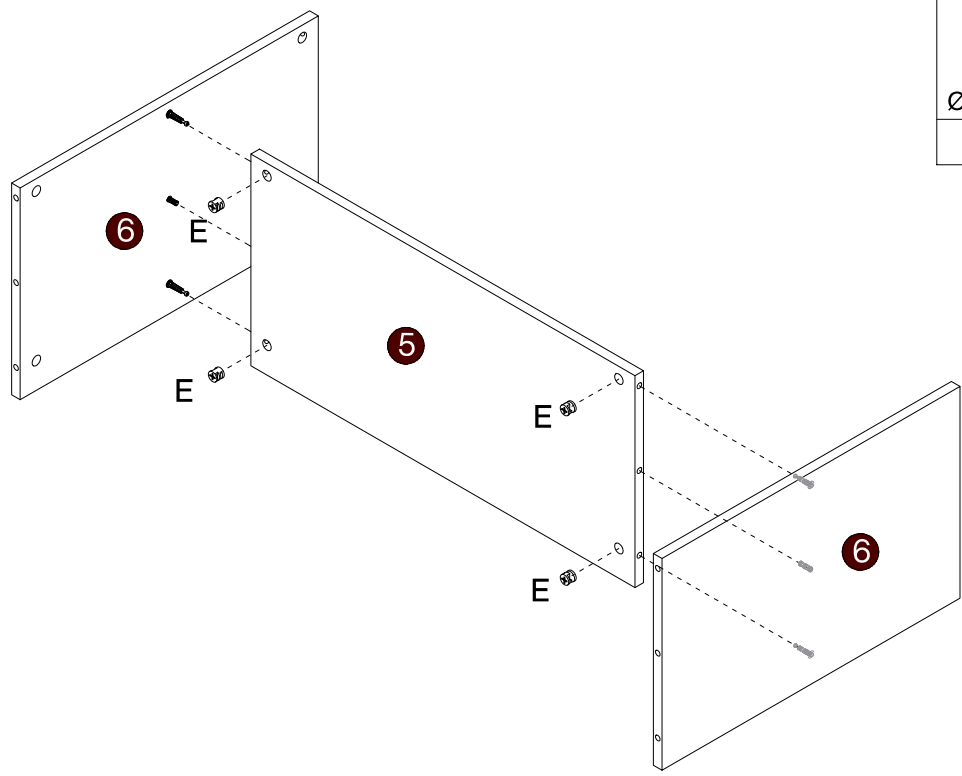
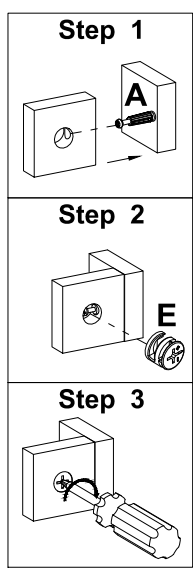
Ø15x12mm
4 pcs



39

Step 1

Step 2

Step 3

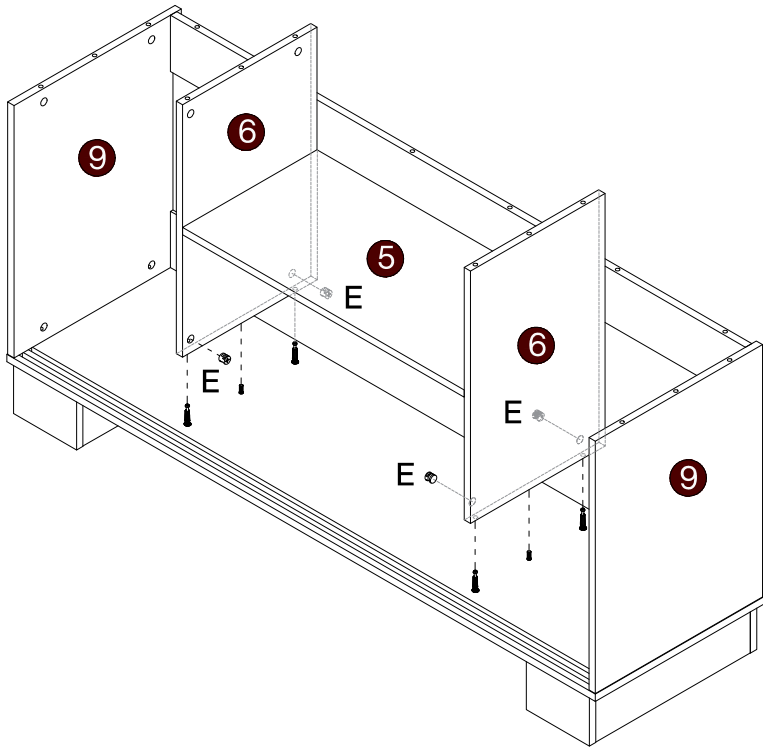

E
Ø15x12mm
4 pcs

40

A	B
M6x35mm	Ø8x30mm
14 pcs	4 pcs

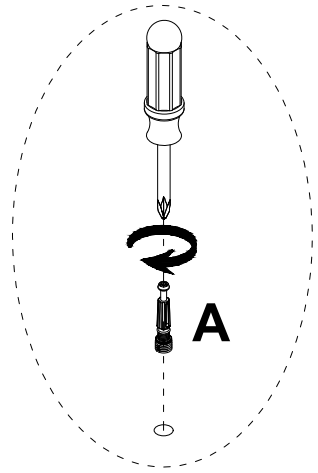
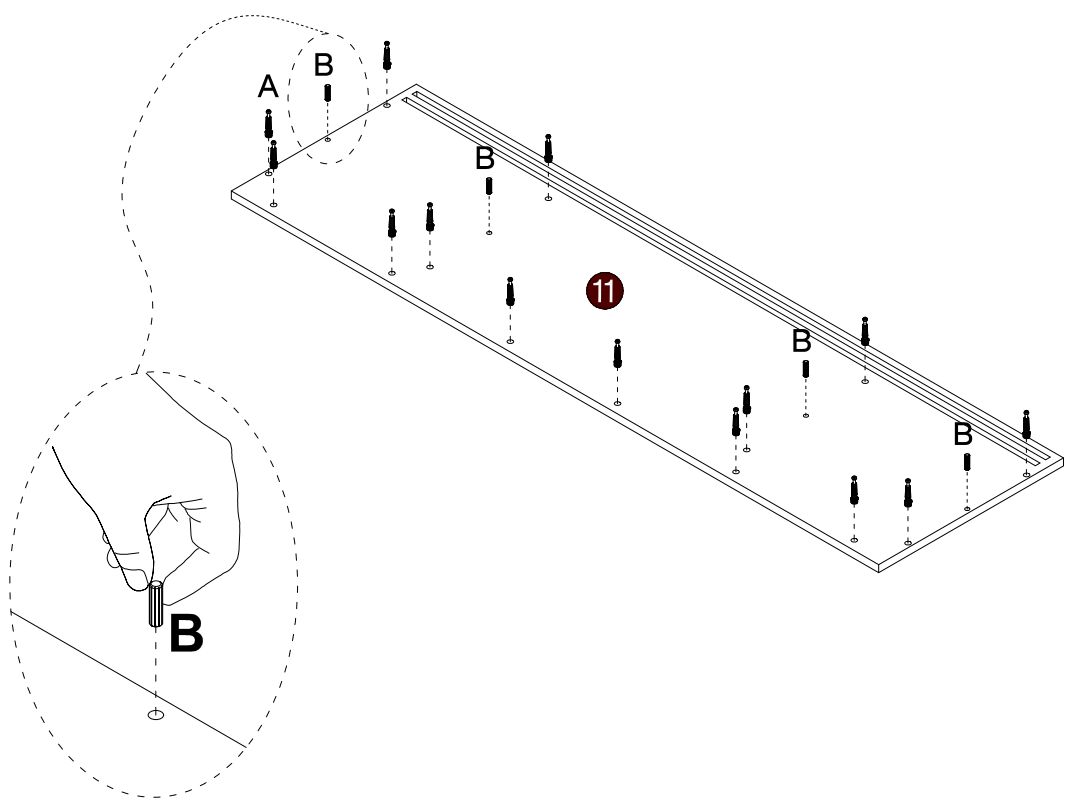

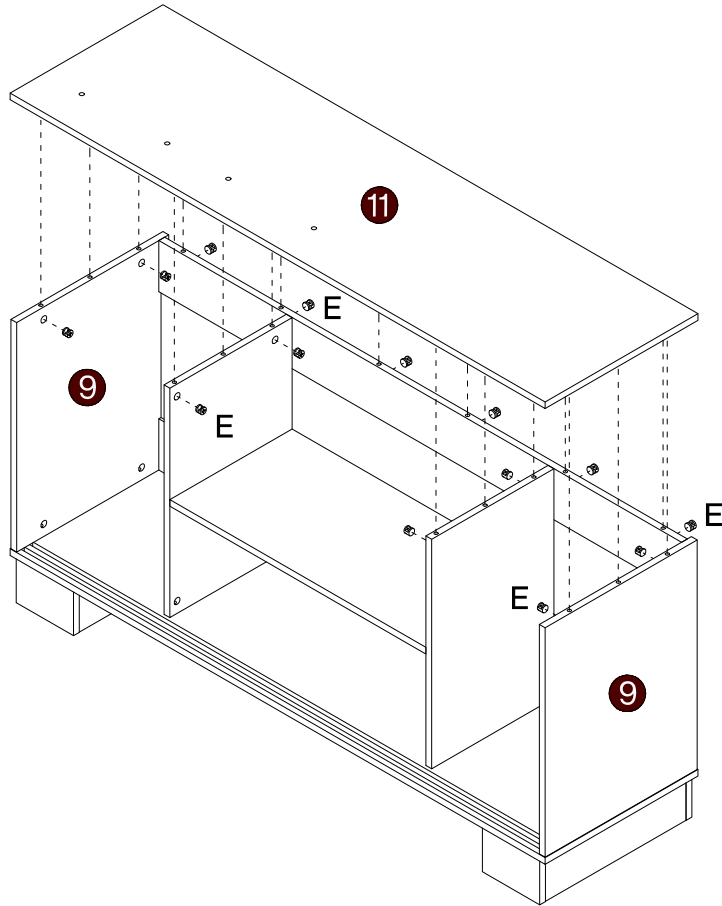
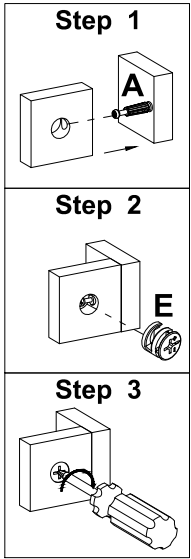

41

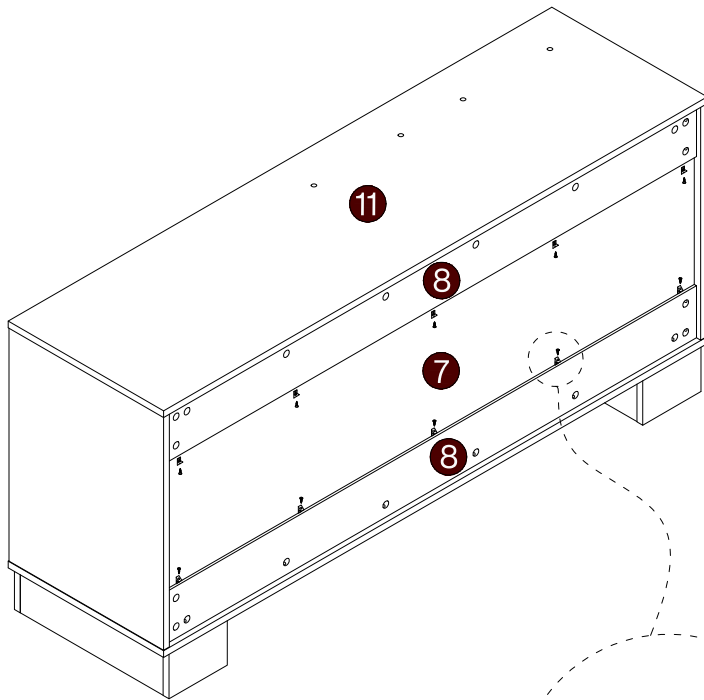

E

Ø15x12mm
14 pcs

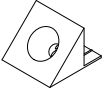
42

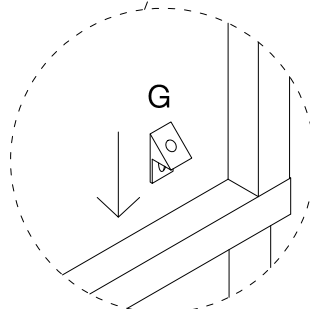

G	H
	
10 pcs	Ø3.5x14mm
10 pcs	10 pcs





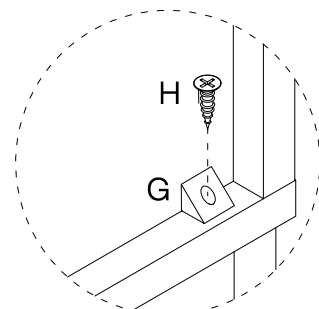

Step 1

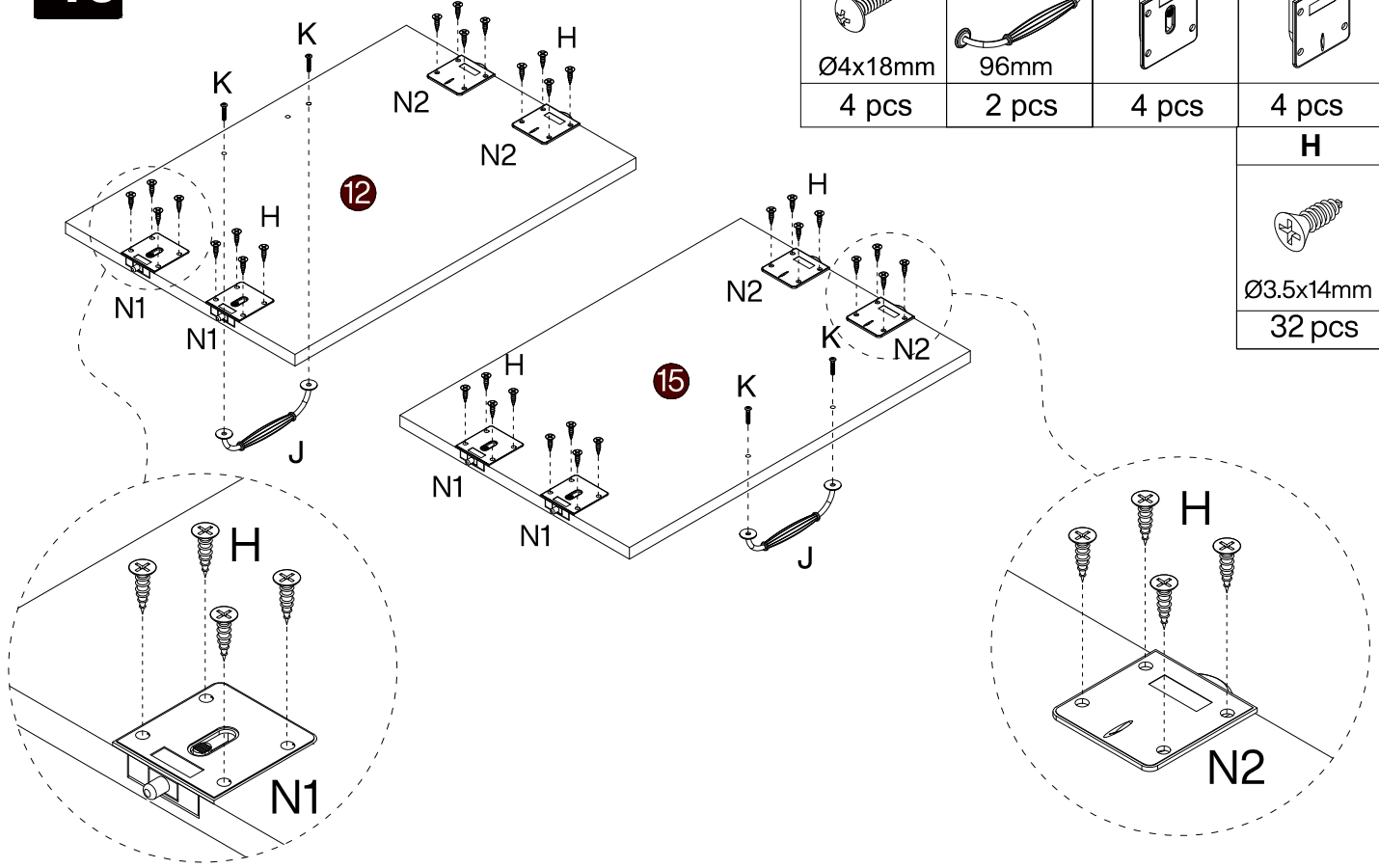

Step 2



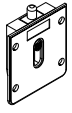
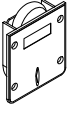

43

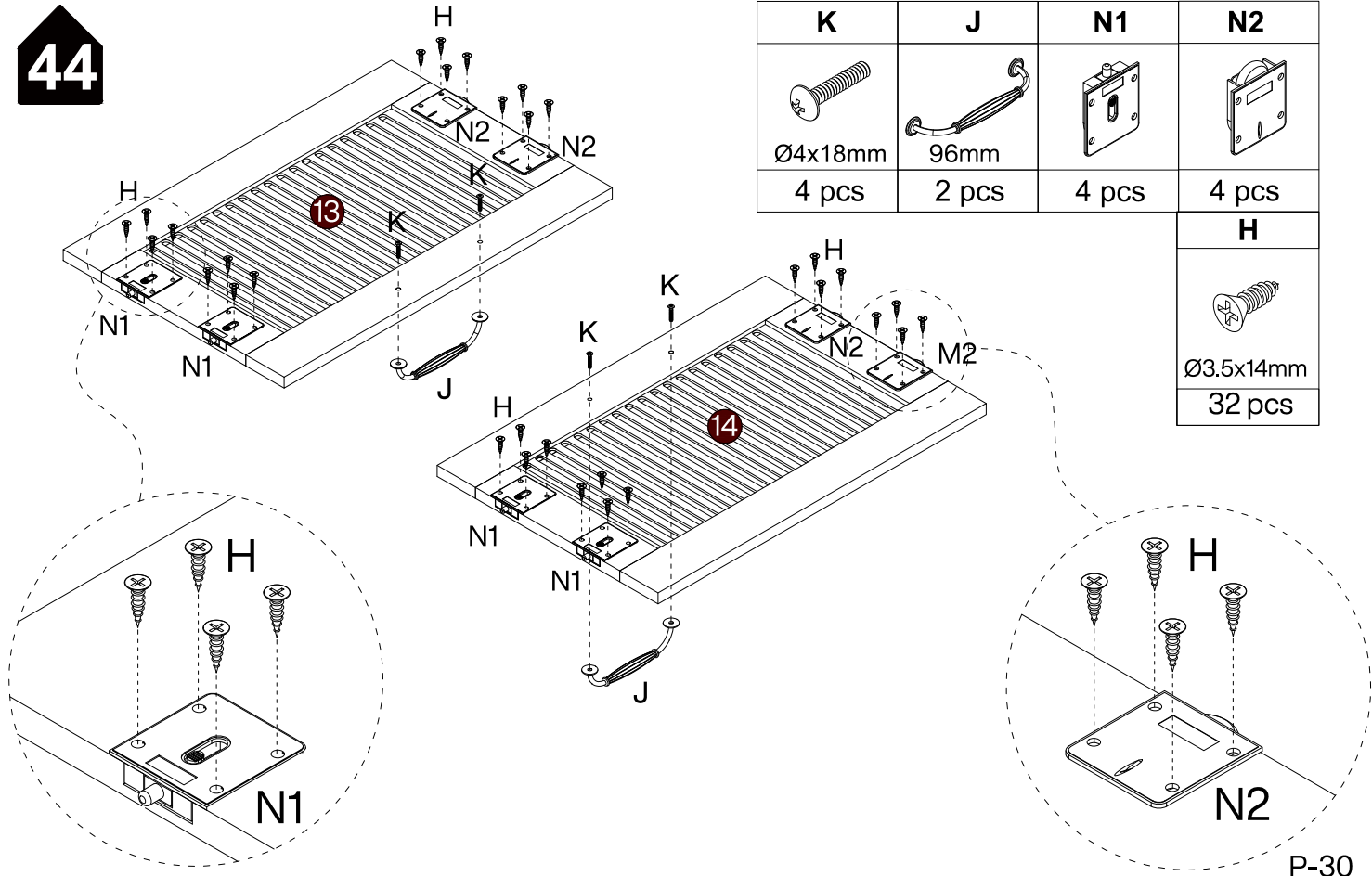

K	J	N1	N2
			
Ø4x18mm	96mm		
4 pcs	2 pcs	4 pcs	4 pcs
H			
			
Ø3.5x14mm			
32 pcs			

44

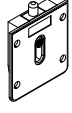
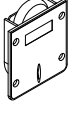

K	J	N1	N2
			
Ø4x18mm	96mm		
4 pcs	2 pcs	4 pcs	4 pcs
H			
			
Ø3.5x14mm			
32 pcs			

45

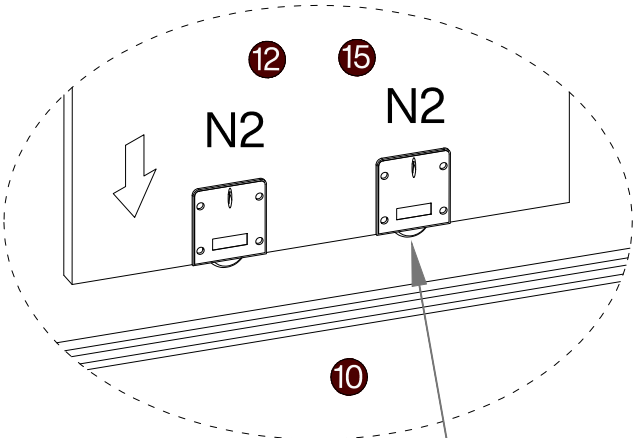
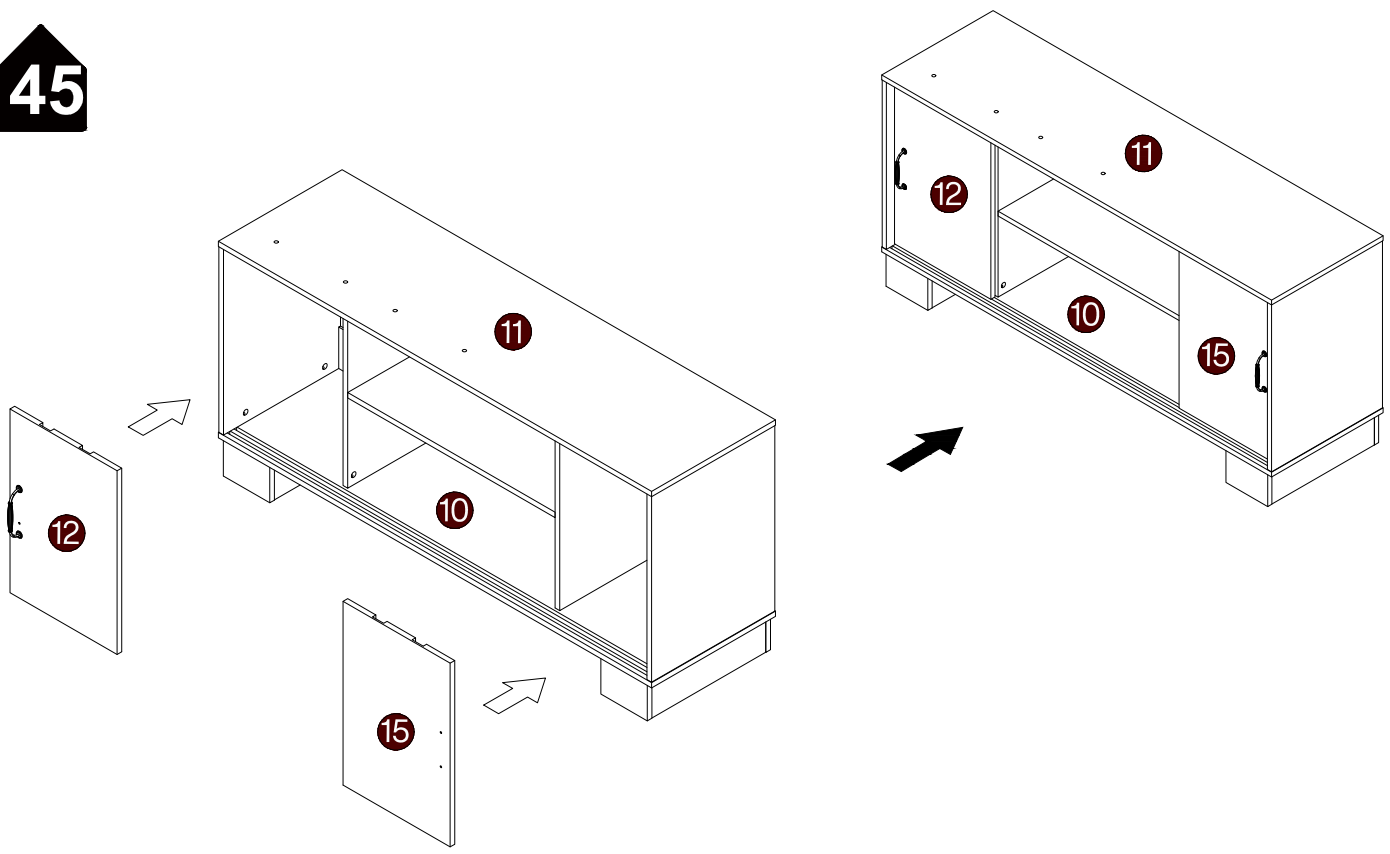

Step 1

Align the wheels of the N2 door wheel with the slot on the board and place it down

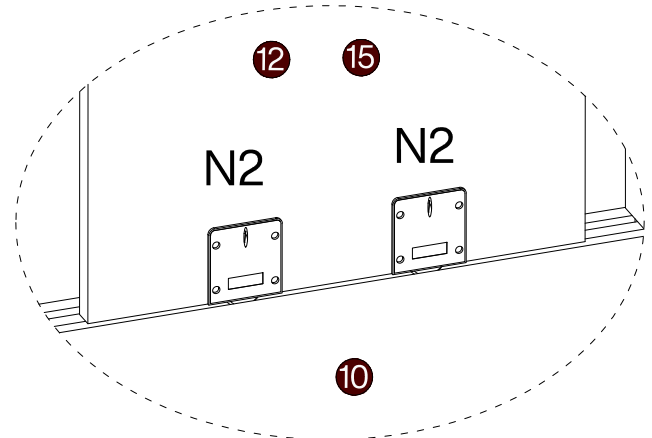

Step 2

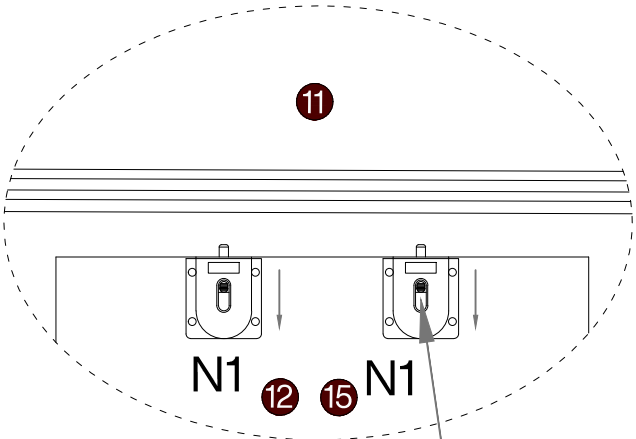

Step 3

Press down on the N1 door wheel switch, and release the hand after the card head on top enters the slot on the board

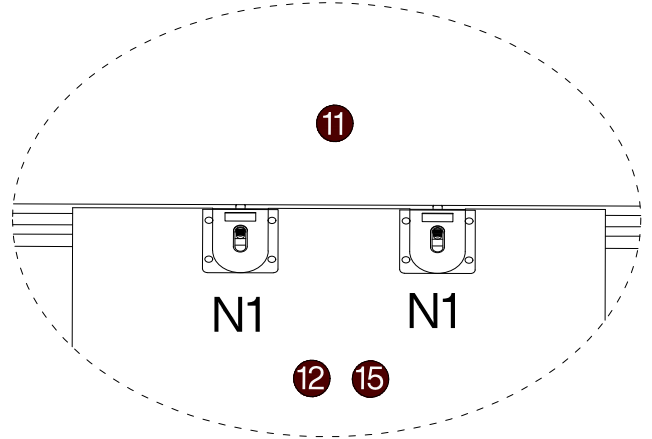

Step 4

46

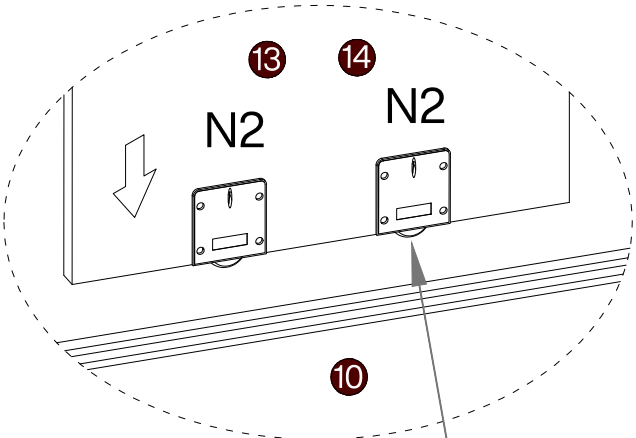
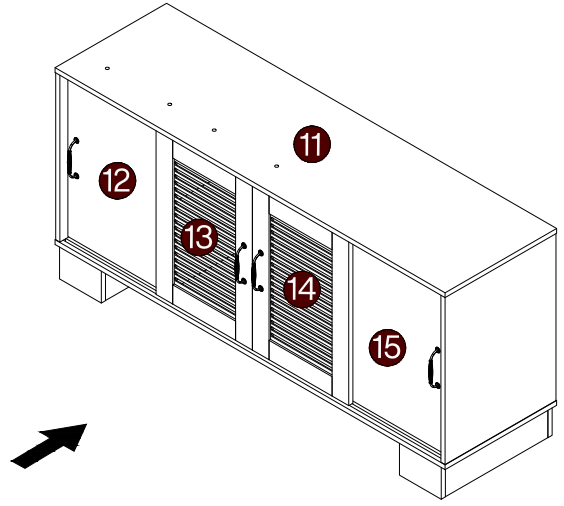
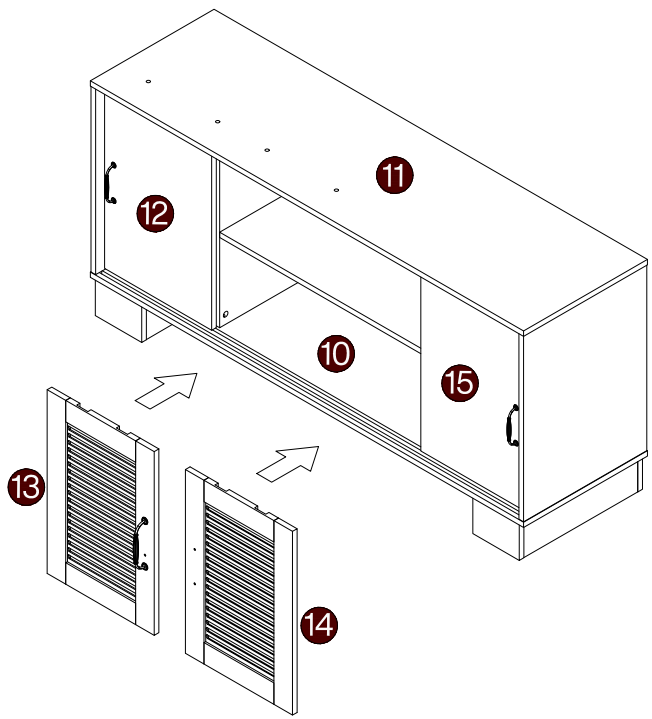

Step 1

Align the wheels of the N2 door wheel with the slot on the board and place it down

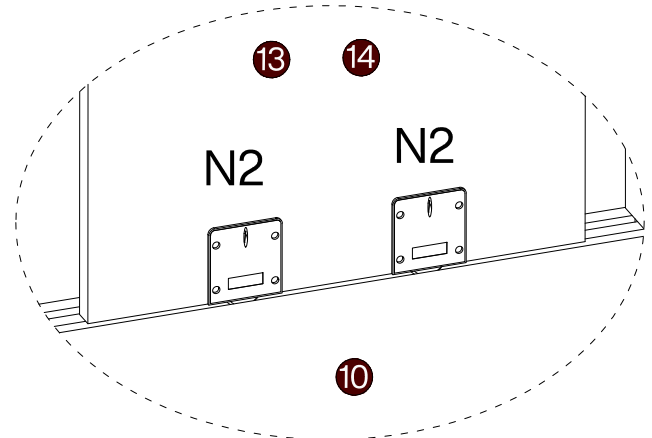

Step 2

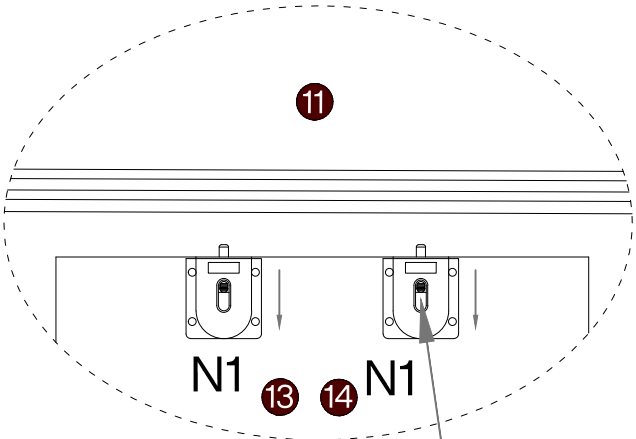

Step 3

Press down on the N1 door wheel switch, and release the hand after the card head on top enters the slot on the board

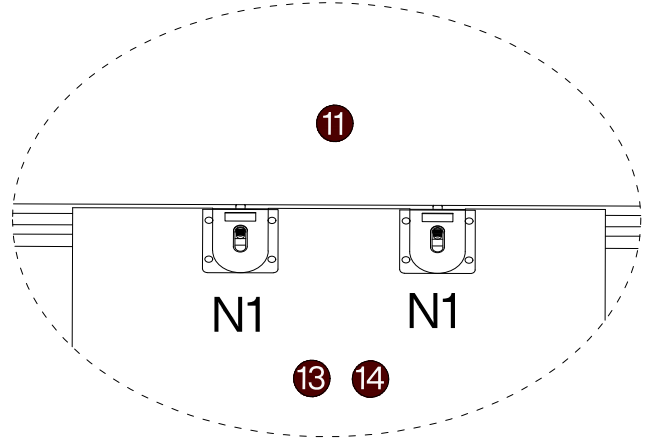

Step 4

47

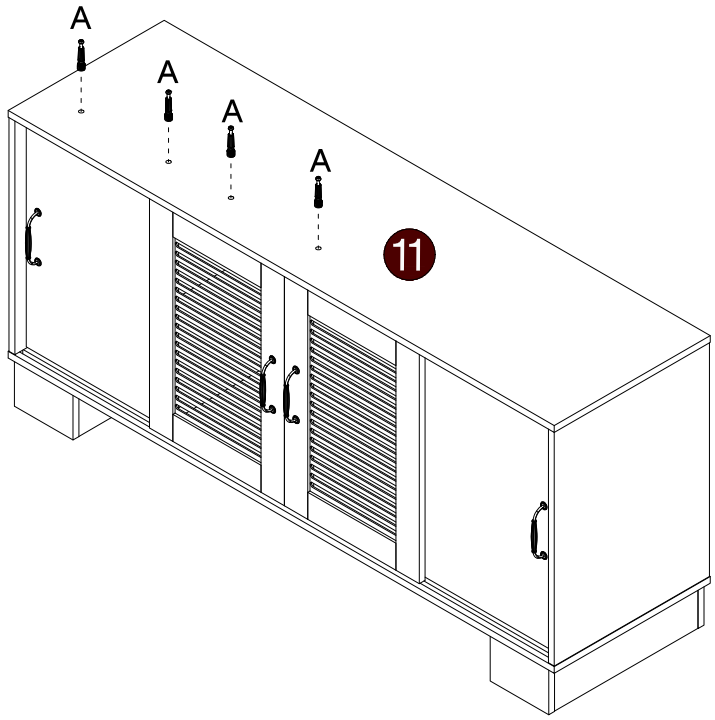

A

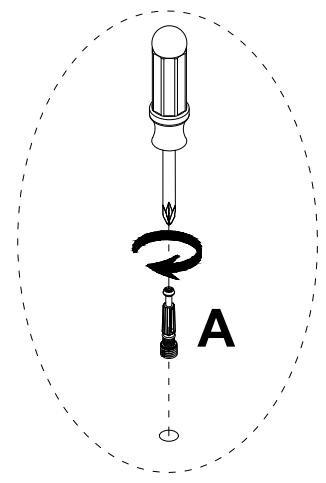
M6x35mm
4 pcs

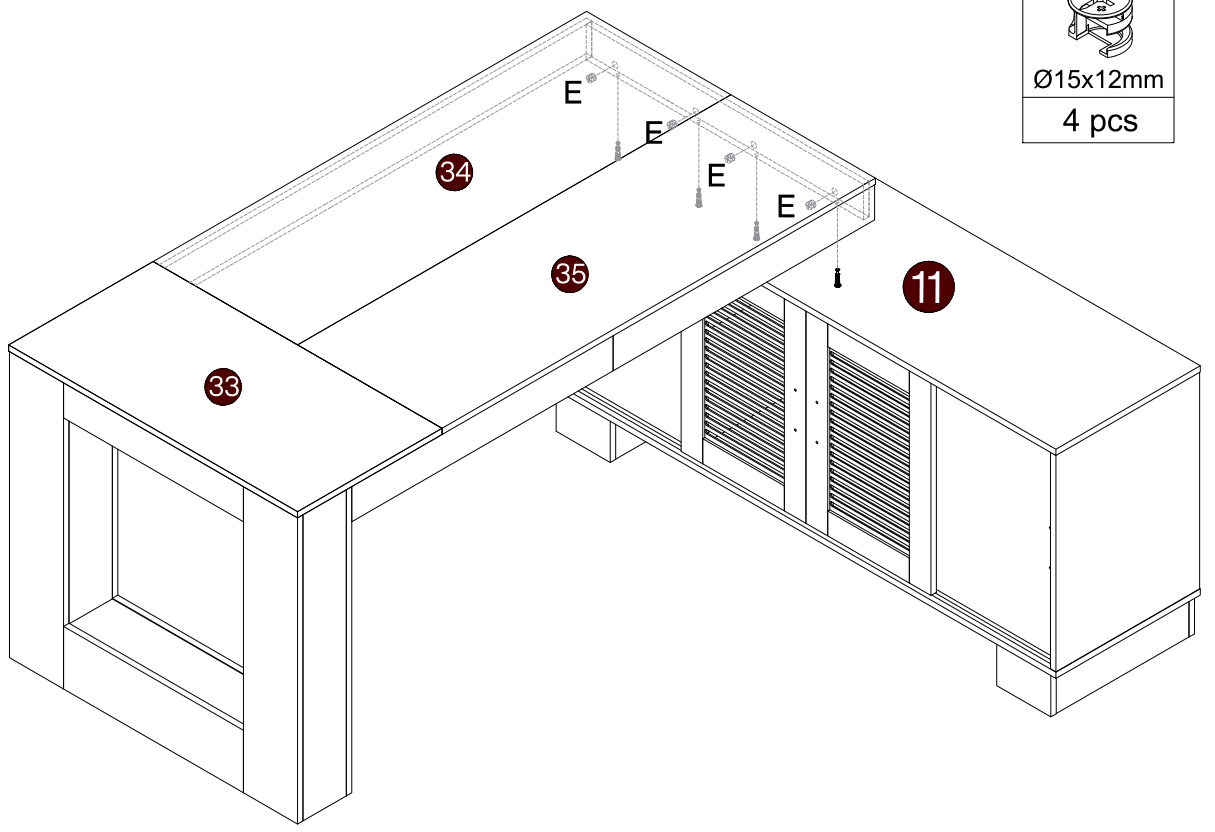
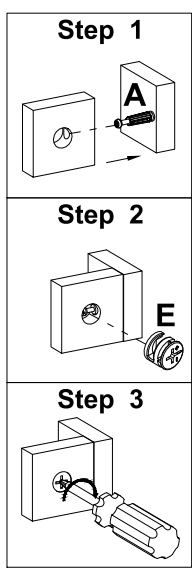

48



E

Ø15x12mm
4 pcs

Thank you for your support !

