

## **Futon Sofa**

# **Assembly Instructions**



## Safety And Care Advice

**Important – Please read these instructions fully before starting assembly.**

1. Please check if all the components and tools listed out are received.
2. Please remove all fittings from the plastic bags and separate them into homologous groups.
3. Please keep children and animals away from the working areas; swallow small parts may cause suffocation.
4. Please make sure you have enough space to lay out the parts before starting.
5. Do not stand on the product, which could cause damage.
6. Please assemble the product as close to its final position as possible.
7. Do not place furniture directly in front of radiators, fires, or any other source of heat.
8. The assembly will be easier with 2 people.
9. Please dispose of all packaging carefully and responsibly.

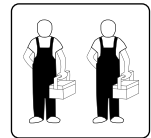

### General care and maintenance

1. Please clean with a damp cloth or mild detergent, do not use bleach or abrasive cleaners.
2. Do not allow the spill to stay on the surface for a long time.
3. Do not clean with products containing the following: acetone (e.g., nail varnish remover), ammonia (e.g.bleach), or sodium hydroxide(e.g., caustic soda, drain, and oven cleaners).
4. If the product is accidentally exposed to the irritating liquid, rinse thoroughly with clean water.
5. Mats can be used to protect surfaces from moisture and heat.
6. Please check whether there are missing screws in the product regularly.
7. The product should not be discarded with household waste, and please take it to your local authority waste disposal center.

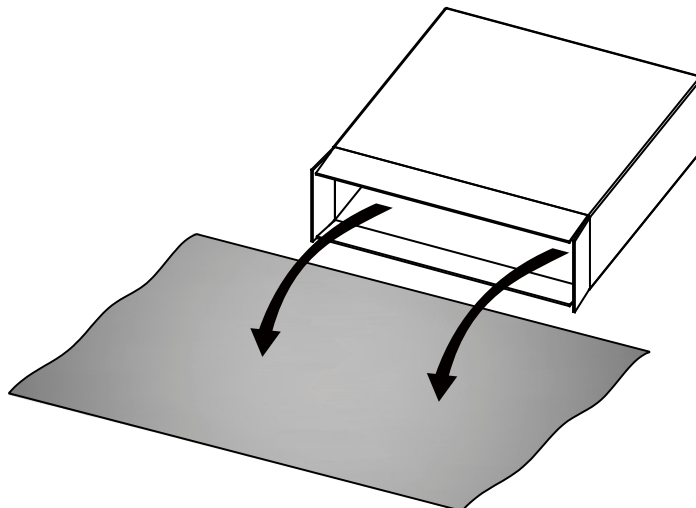

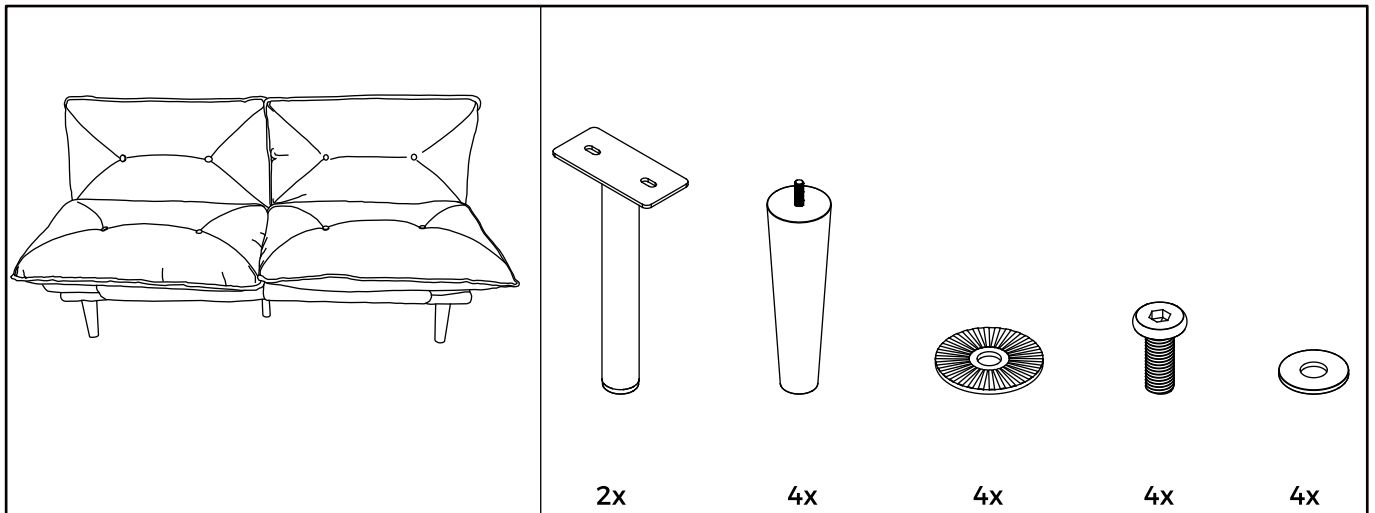
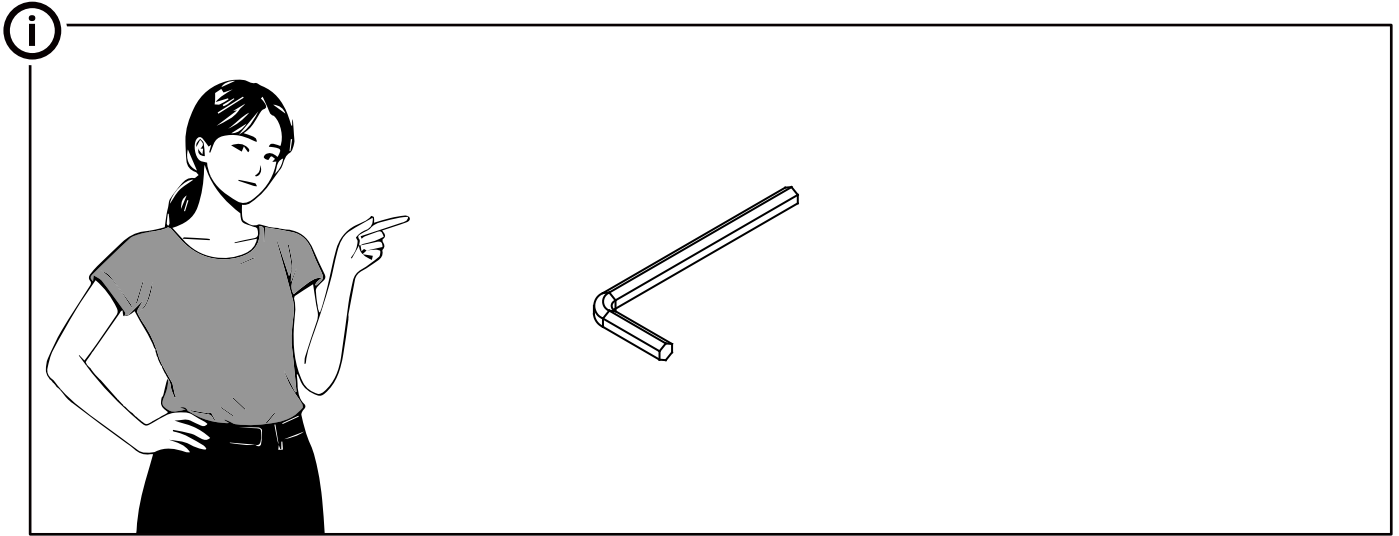

### Tips For Restoring Vacuum Compressed Parts:

1. **Unpackaging:** Remove the cushions from the vacuum-sealed packaging.
2. **Allow Expansion Time:** Let the cushions sit in a well-ventilated area for a few hours to expand naturally. It usually needs 36-72 hours to fully expand.
3. **Fluffing and Patting:** Gently fluff and pat the cushions to encourage air circulation and restore their shape.
4. **Massage and Knead:** Lightly massage and knead the cushions to redistribute the filling evenly.
5. **Apply Heat (Optional):** Using a hairdryer on a low-heat setting or placing a warm, damp cloth over the cushions can expedite the process and remove wrinkles.

# 1

Open the packaging box and carefully take out the items.

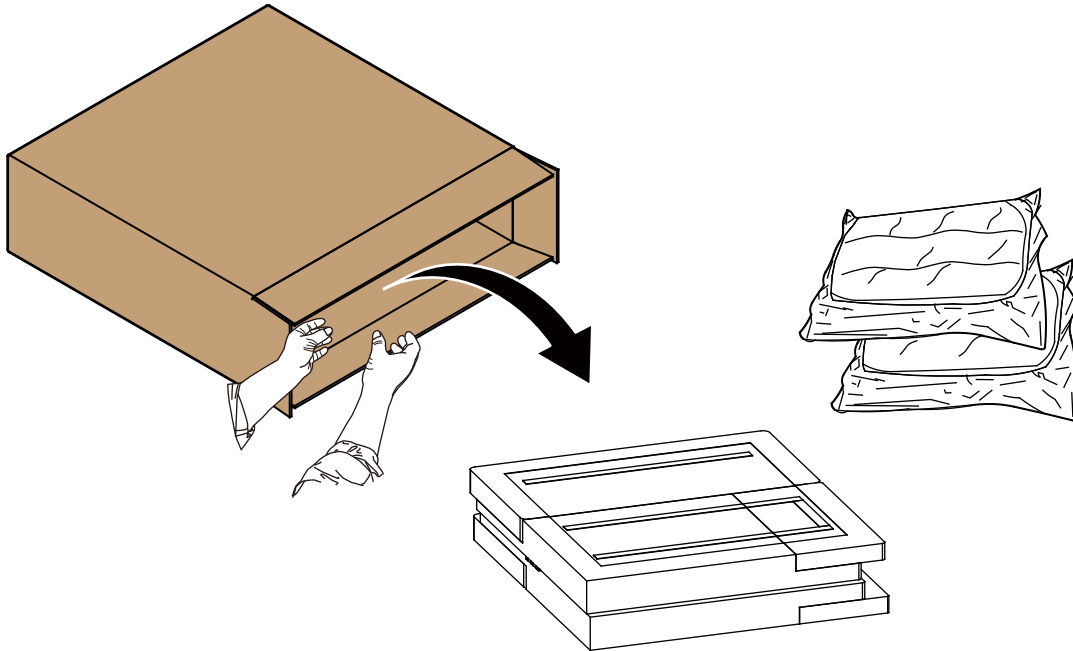

**Allow 36-72 hours for the cushion to inflate fully.**

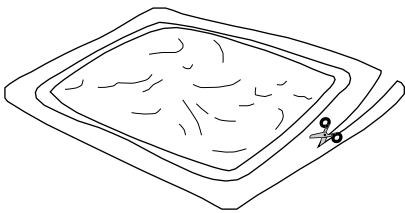

**Step 1:**  
Cut and open the package

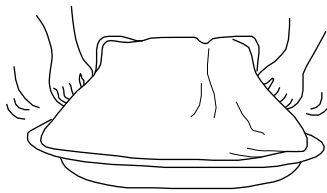

**Step 2:**  
Rotate the cushion multiple times and pat from the sides

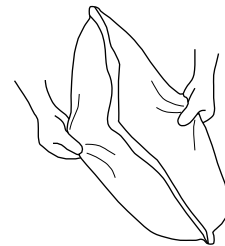

**Step 3:**  
Gently pull the fabric cover and cushion filling outward

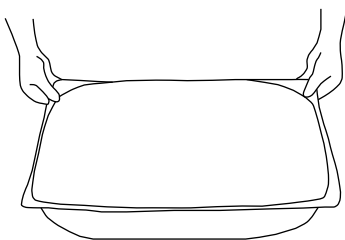

**Step 4:**  
Straighten the edges of the fabric cover

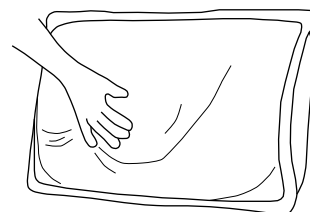

**Step 5:**  
Lightly pat the surface to smooth wrinkles

2

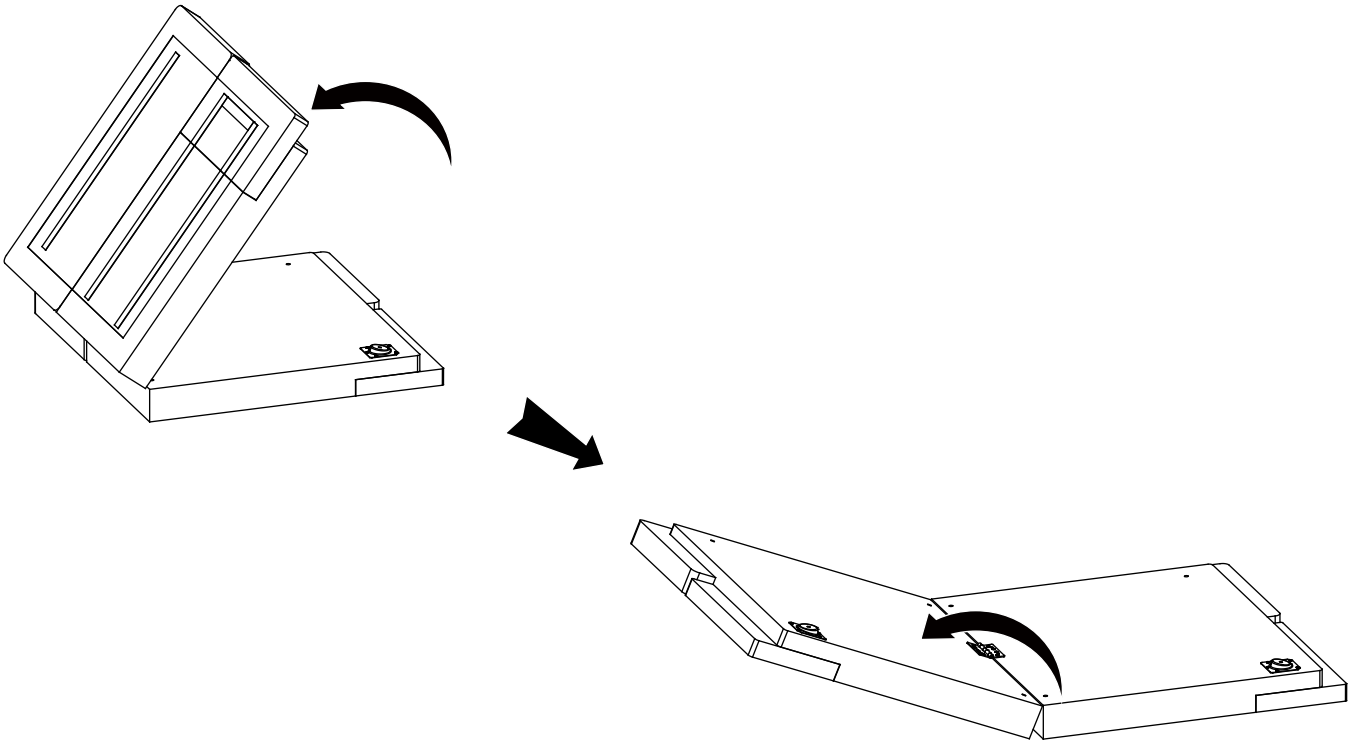

3

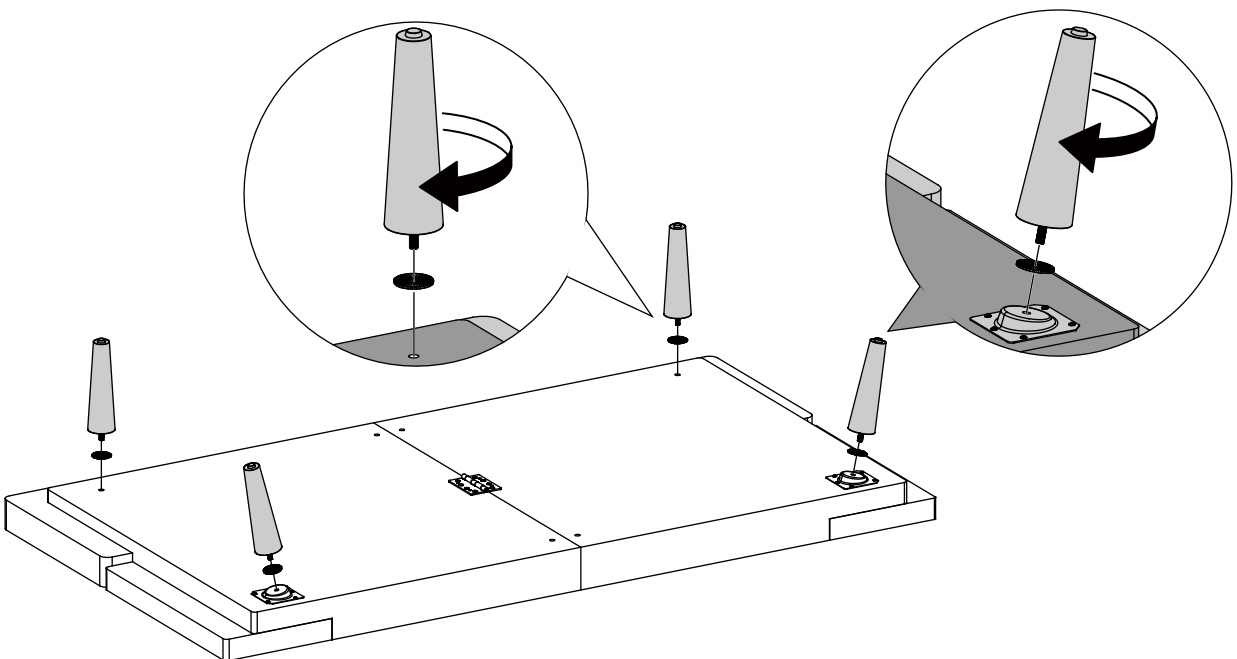

4

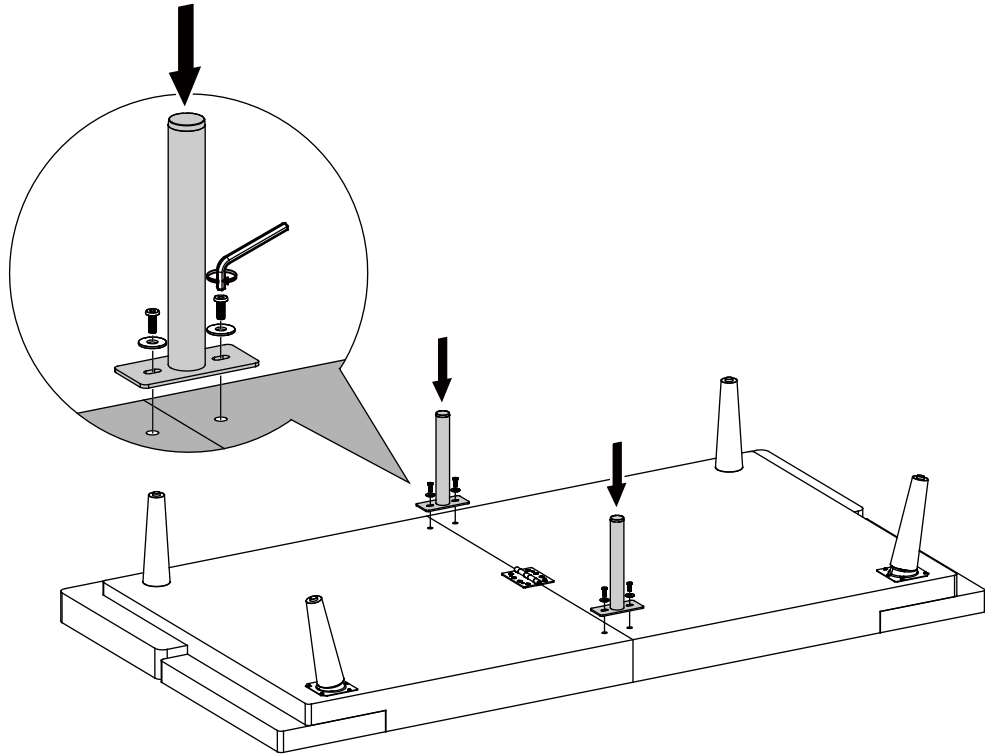

5

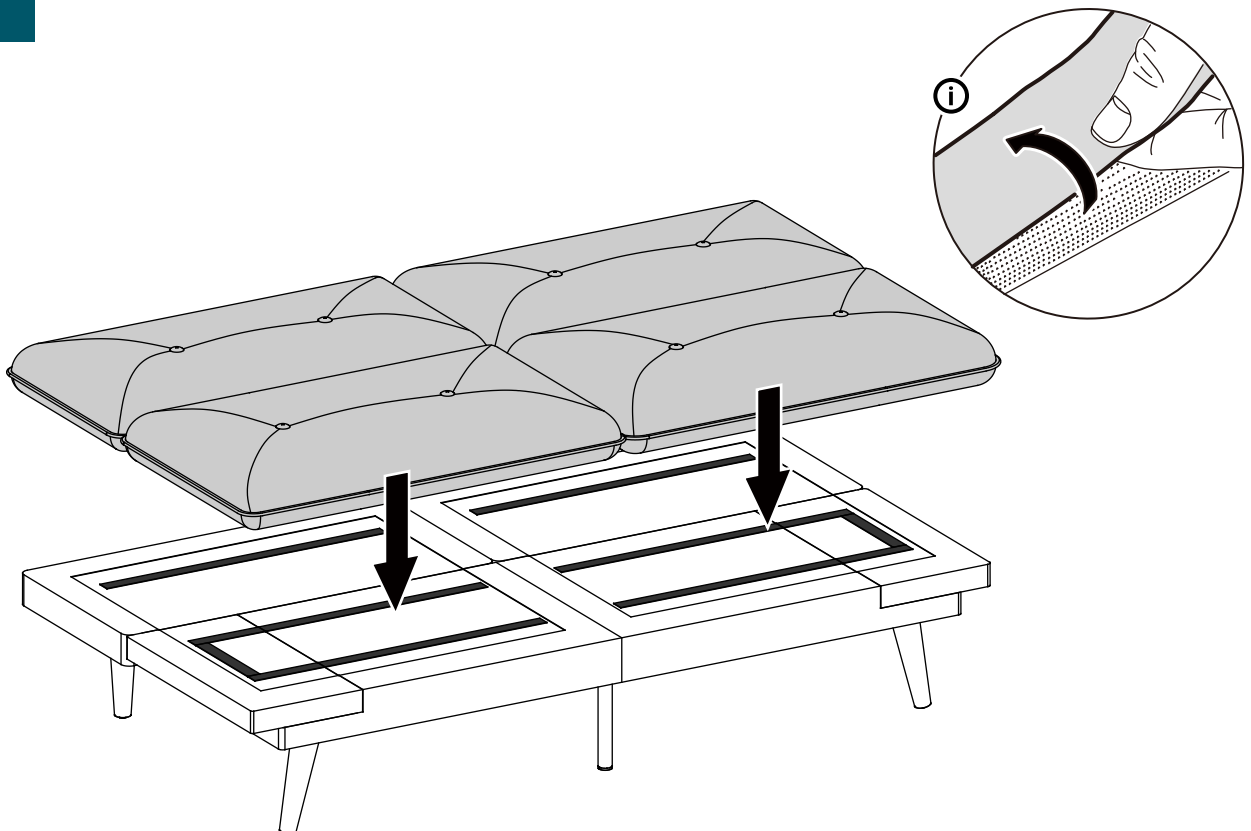

# 6

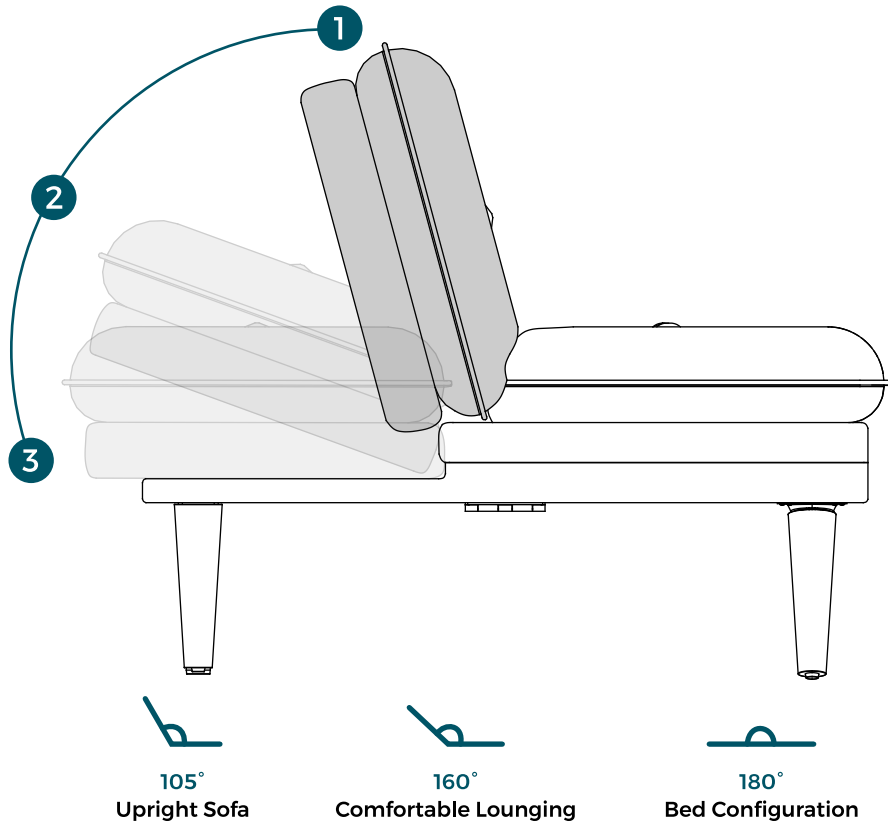

# 7

