

ASSEMBLY INSTRUCTIONS

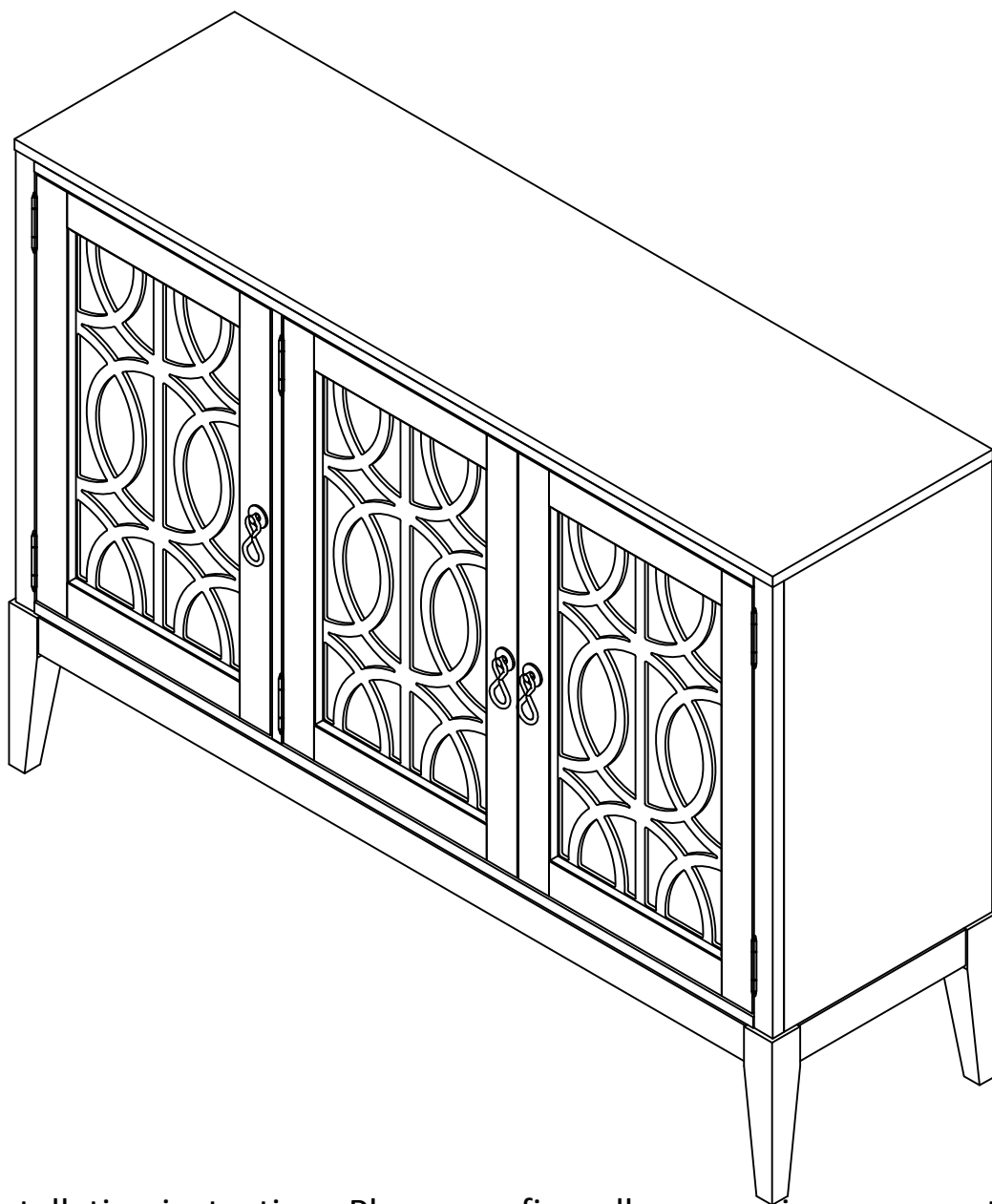

Notice:

1. Follow the installation instructions. Please confirm all accessories are preset before installation.
2. Do not fully tighten the screws during initial assembly. Fully tighten screws only once all pieces are correctly assembled.
3. If you encounter any problems during installation, please contact our customer service.
4. Please unbox the item from the side with an open-label and put a carpet on the floor to avoid scratching it.

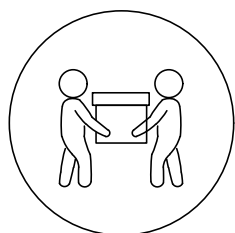

Recommended
installers :2

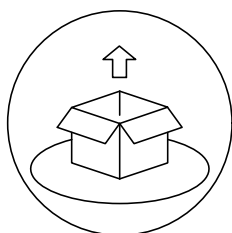

Put a carpet on the floor
before unpacking

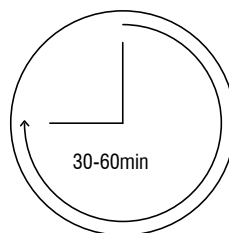

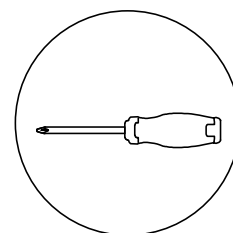

Estimate
installation time





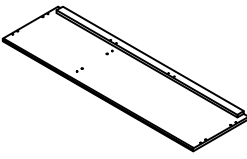
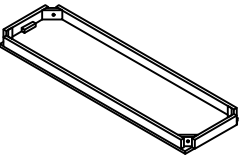
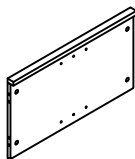
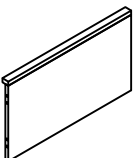
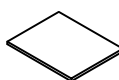
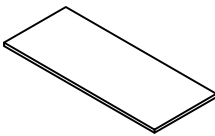

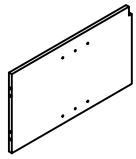
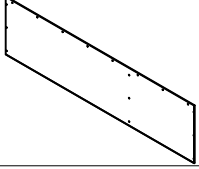
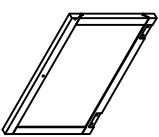
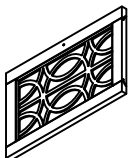
Screw driver needed
But not included



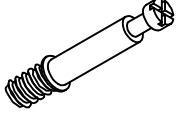

Accessories List

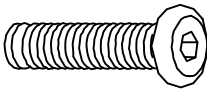
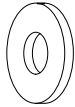
Item no.	Reference Image	Qty
1		1
2		1
3		1
4		1
5		1
6		1

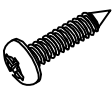
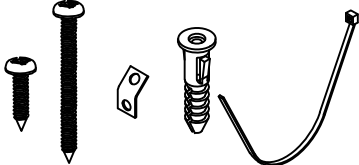
Item no.	Reference Image	Qty
7		1
8		2
9		2
10		1
11		4

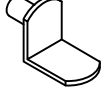
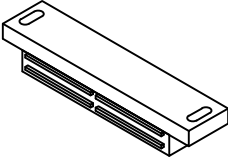
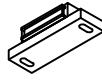
Hardware List

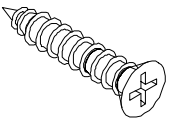
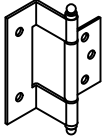
Item no.	Reference Image	Qty
A	M6*36 	12+1
B	Ø15*9 	12+1
C	Ø8*30 	12+1
D	5/16"*45 	4
	Ø8*14 	4
	Ø8 	4
E	5 	1
F	M3*16 	38+2
G		2

Item no.	Reference Image	Qty
H	Ø6*10 	8
I	71*16*12 	1
	44*16*12 	1
	35*12*1 	3
J	M3*16 	45+2
K	85*59*58 	6
L	68*28*12 	3
	M4*25 	3

ASSEMBLY INSTRUCTIONS

1

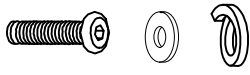

D 4pcs

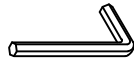

E 1pc

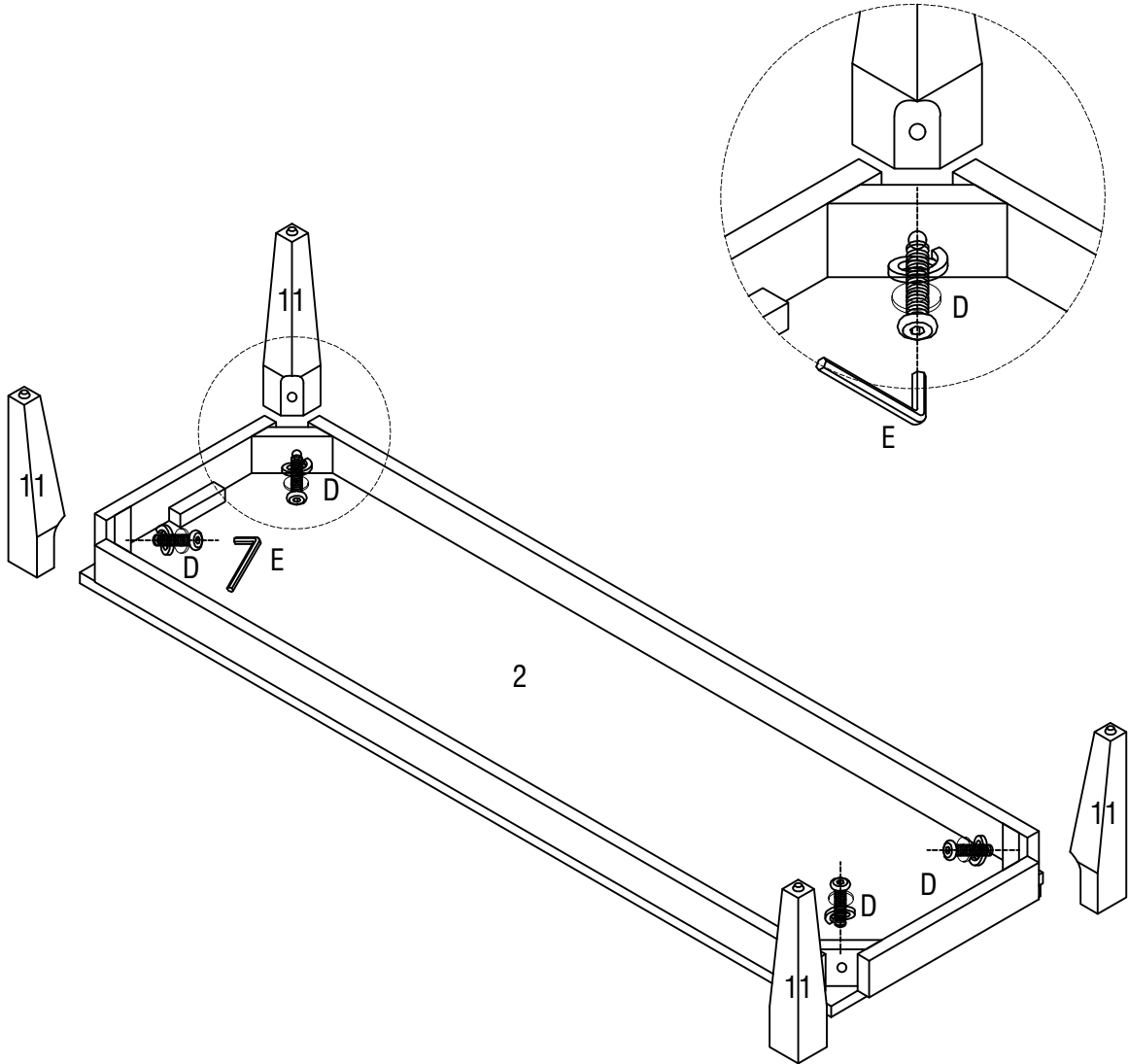

ASSEMBLY INSTRUCTIONS

2



A 6pcs



B 6pcs



C 6pcs

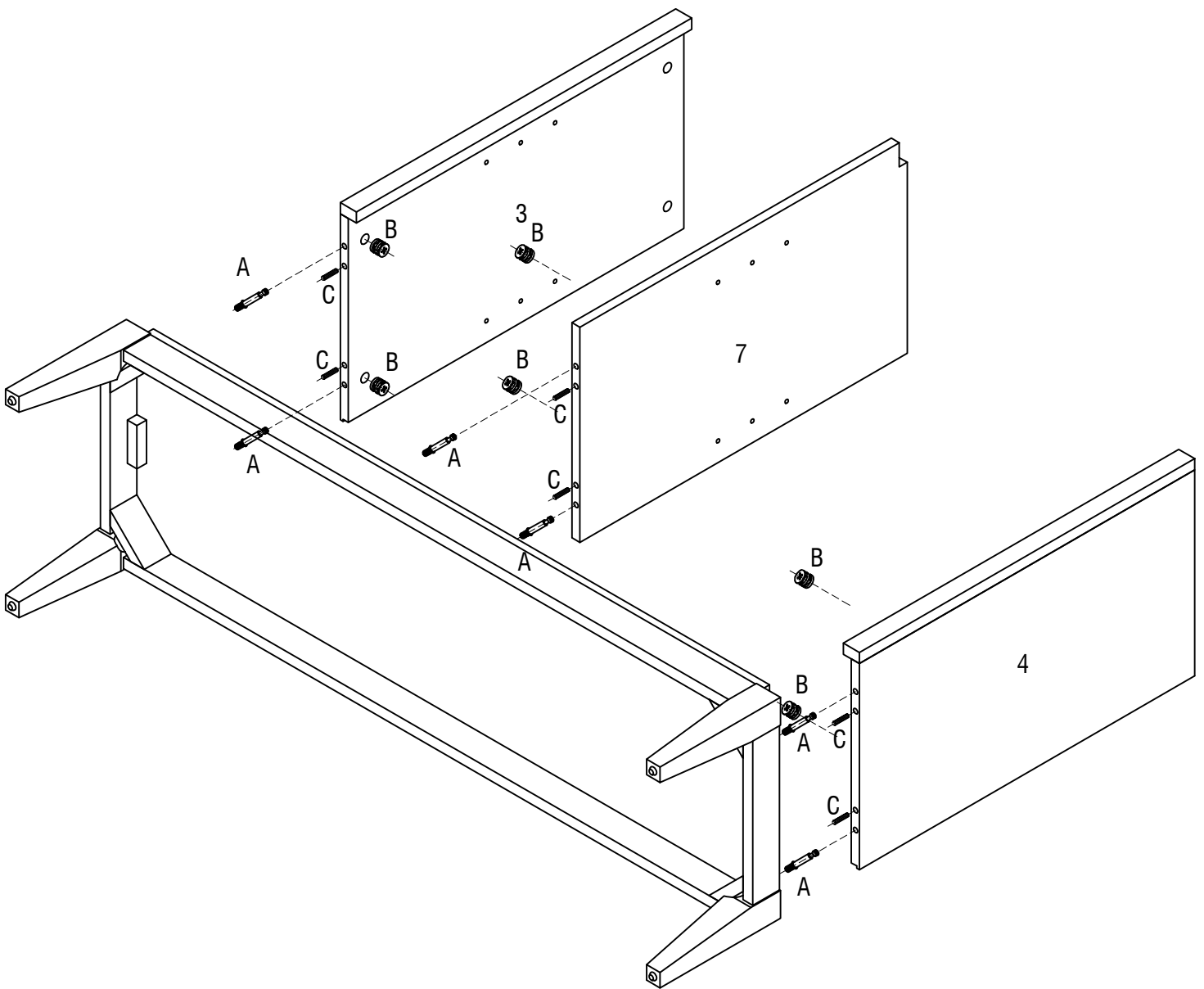

ASSEMBLY INSTRUCTIONS

3



A 6pcs



B 6pcs



C 6pcs

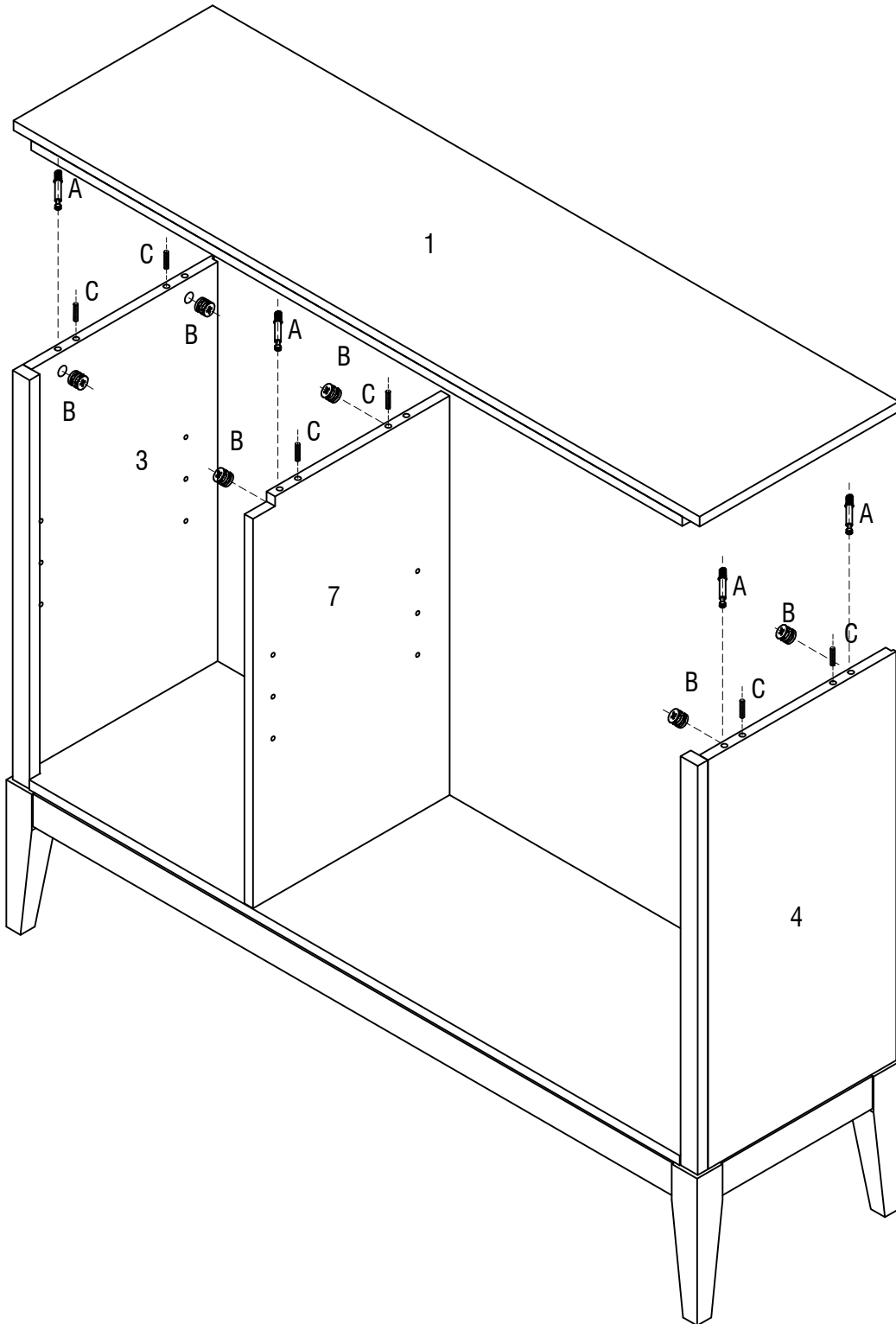

5

ASSEMBLY INSTRUCTIONS

4



F 34pcs



G 2pcs

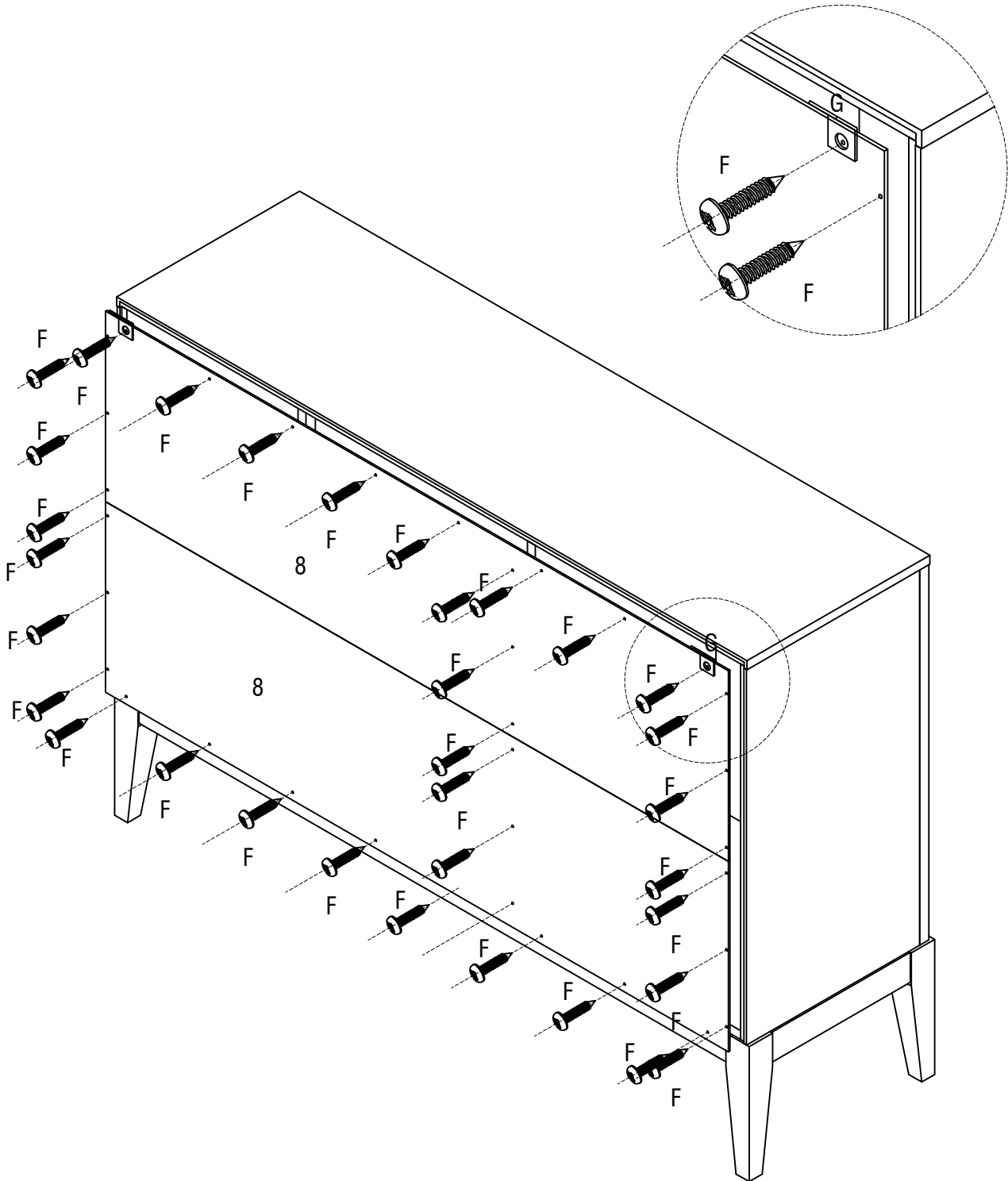

ASSEMBLY INSTRUCTIONS

5

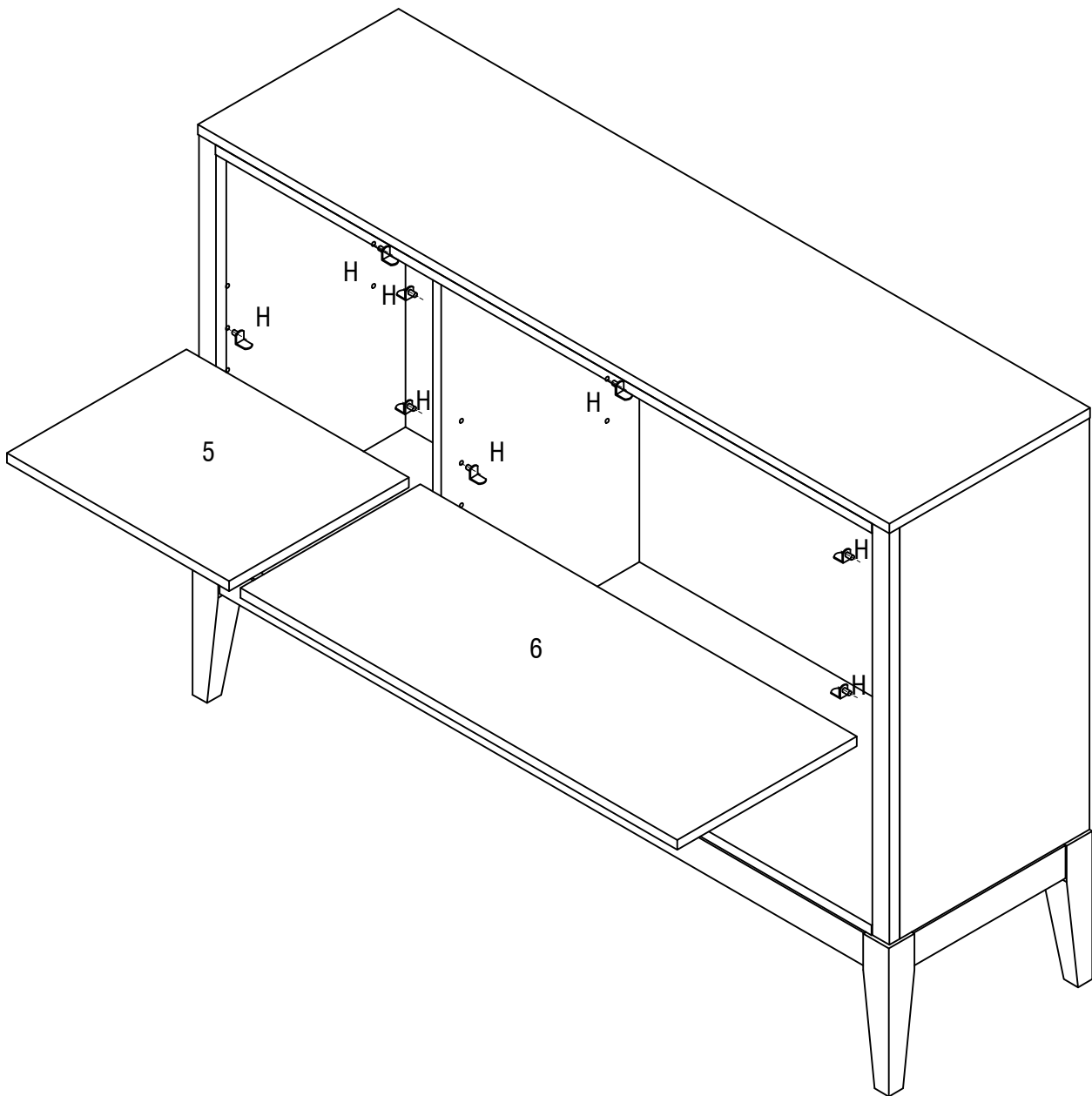

H 8pcs



ASSEMBLY INSTRUCTIONS

6

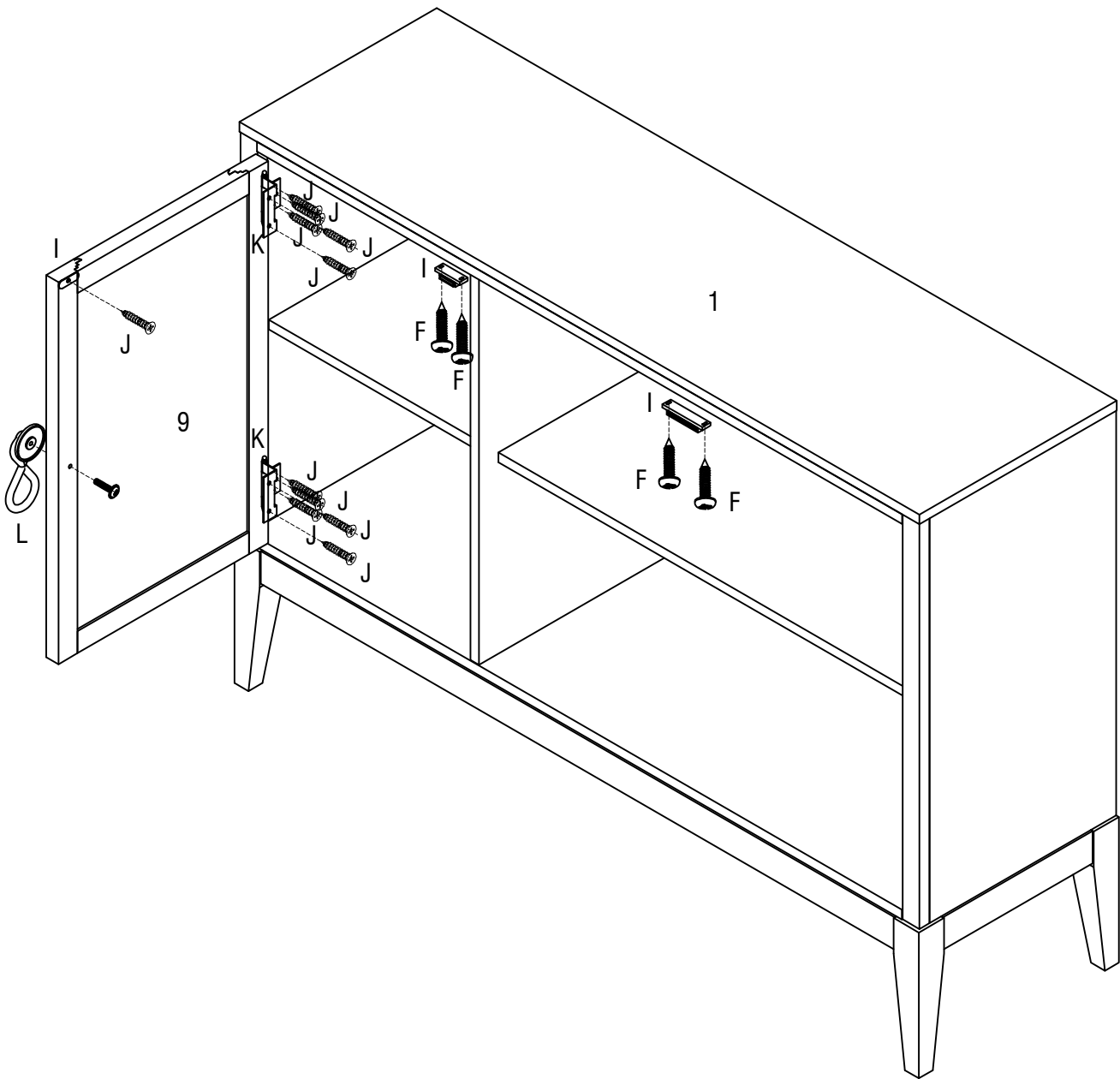
- I 1pc
- 1pc
- 3pcs
- F 4pcs
- L 3pcs
- 3pcs
- K 6pcs
- J 45pcs



ASSEMBLY INSTRUCTIONS

7



G 2pcs

