

SEMI FLUSH CEILING MOUNT ASSEMBLY/INSTALLATION INSTRUCTIONS

Please read carefully and save these instructions, as you may need them at a later date.

CAUTION

WARNING: Risk of Fire. Min 90°C supply conductors. Consult a qualified electrician to ensure correct branch circuit conductor.

Turn off the main power at the circuit breaker before installing the fixture, in order to prevent possible shock.

GENERAL

All electrical connections must be in accordance with local and National Electrical Code (N.E.C.) standards. If you are unfamiliar with proper electrical wiring connections obtain the services of a qualified electrician.

Remove the fixture and the mounting package from the box and make sure that no parts are missing by referencing the illustrations on the installation instructions.

ASSEMBLY AND INSTALLATION

1. Pull the SUPPLY WIRES and SUPPLY GROUND WIRE out from the JUNCTION BOX and attach the CROSSBAR to the JUNCTION BOX using the slotted holes on the CROSSBAR and the JUNCTION BOX SCREWS provided.
2. Thread the FIXTURE SCREWS two full turns into the appropriate threaded holes in the CROSSBAR. (Check the CROSSBAR against the CANOPY keyhole to ensure proper fit.)
3. Make the wiring connection: Connect the FIXTURE GROUND WIRE to the SUPPLY GROUND WIRE with a WIRE NUT and then secure them to the CROSSBAR with the GREEN GROUND SCREW. Connect the BLACK SUPPLY WIRE to the BLACK FIXTURE WIRE and WHITE SUPPLY WIRE TO WHITE FIXTURE WIRE with WIRE NUTS.
4. Carefully tuck all wiring back into the JUNCTION BOX. Lift the CANOPY over the JUNCTION BOX, positioning the FIXTURE SCREWS ends through the Keyhole and Secure both with LOCK NUTS.
5. Install the BULBS (Sold Separately) referring to fixture markings or labels for maximum wattage. Do not exceed the Maximum Wattage!
6. Locate the GLASS SHADE. Thread the METAL WASHER A and PLASTIC WASHER A onto the bottom end of the NIPPLE. Carefully lift up the GLASS SHADE, Align and pass the NIPPLE through the center hole in the bottom of GLASS SHADE. Thread the PLASTIC WASHER B, METAL WASHER B and HEX NUT at the bottom of the NIPPLE.
7. Locate the CAP & FINIAL, Thread the FINIAL onto the end of NIPPLE protruding from GLASS SHADE.
8. Restore electric power to installation point ON . Retain this sheet for future reference.

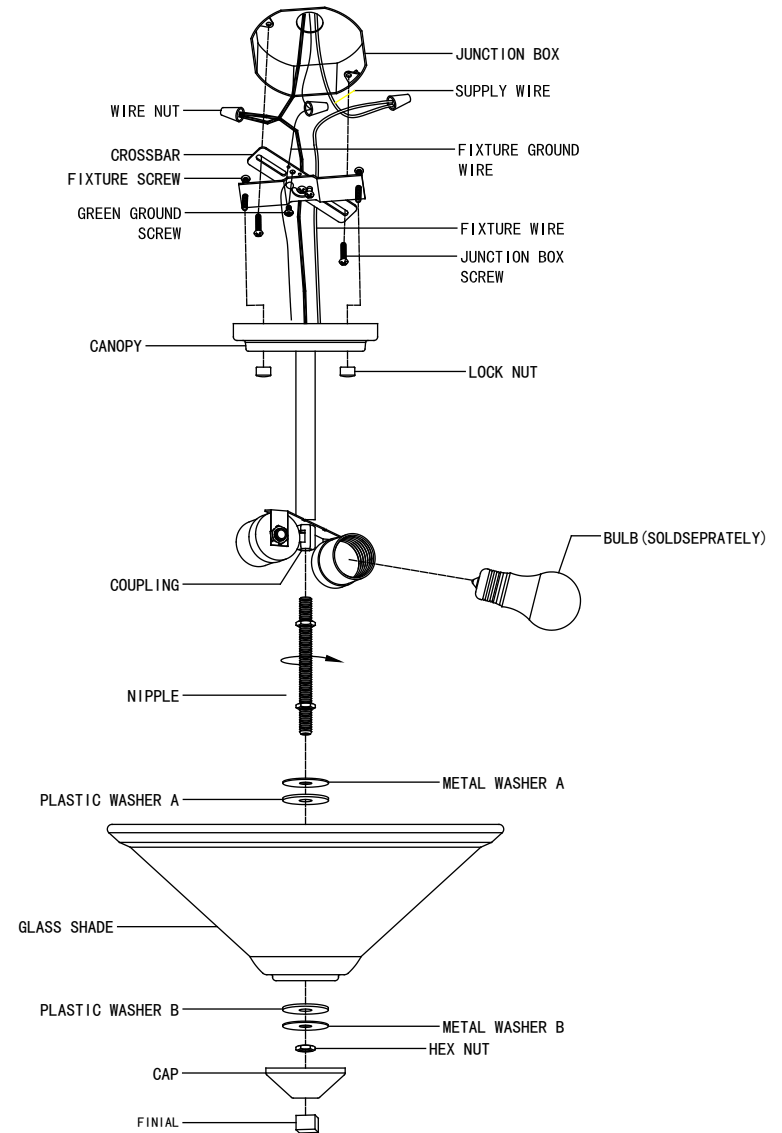

**IF IN DOUBT ABOUT ELECTRICAL INSTALLATION,
CONSULT A LICENSED ELECTRICIAN.**