

Assembly Instruction





ASSEMBLY TIPS:

1. Remove hardware from box and sort by size.
2. Please check to see that all hardware and parts are present prior to start of assembly.
3. Please follow attached instructions in the same sequence as numbered to assure fast & easy assembly.



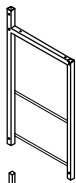
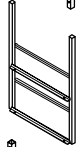
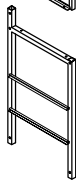
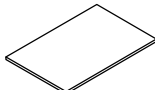
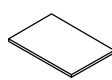

Warning!

1. Don't attempt to repair or modify parts that are broken or defective. Please contact the store immediately.
2. This product is for home use only and not intended for commercial establishment.



PARTS IDENTIFICATION:

- | | | |
|------------------------|---|------|
| A. SIDE FRAME – LEFT |  | 1 PC |
| B. SIDE FRAME – MIDDLE |  | 1 PC |
| C. SIDE FRAME – RIGHT |  | 1 PC |
| D. TOP SHELF |  | 1 PC |
| E. SHELF |  | 2PCS |
| F. SQUARE TUBE |  | 4PCS |
| G. POST |  | 1 PC |
| H. BASKET |  | 2PCS |

HARDWARE PACKAGE 1 :

Z	DESCRIPTION	FIGURE	QTY
1	BOLT		14PCS
2	SCREW-LARGE		4PCS
3	SCREW-SMALL		8PCS
4	BOTTOM CAP		4PCS
5	TOP CAP		2PCS

HARDWARE PACKAGE 2 :

Z	DESCRIPTION	FIGURE	QTY
6	CASTER		2PCS
7	LOCKING CASTER		2PCS

A person assembles time for 30 minutes.

STEP 1

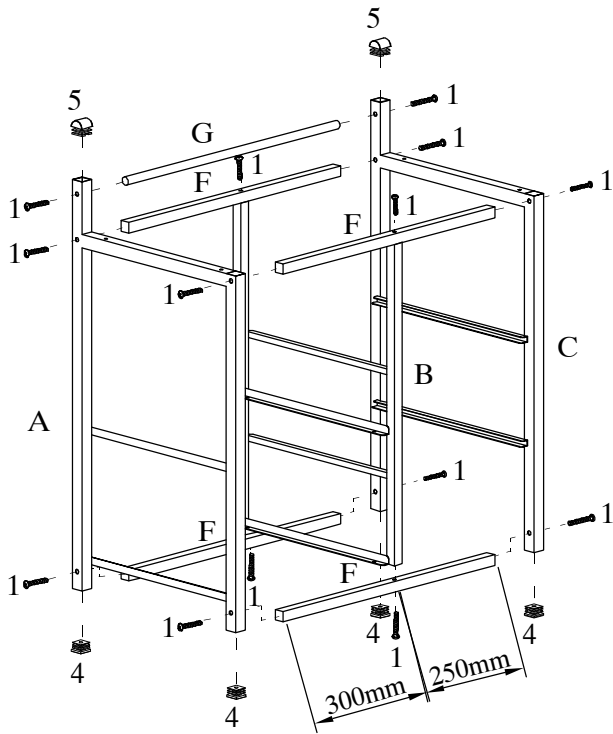

STEP 2

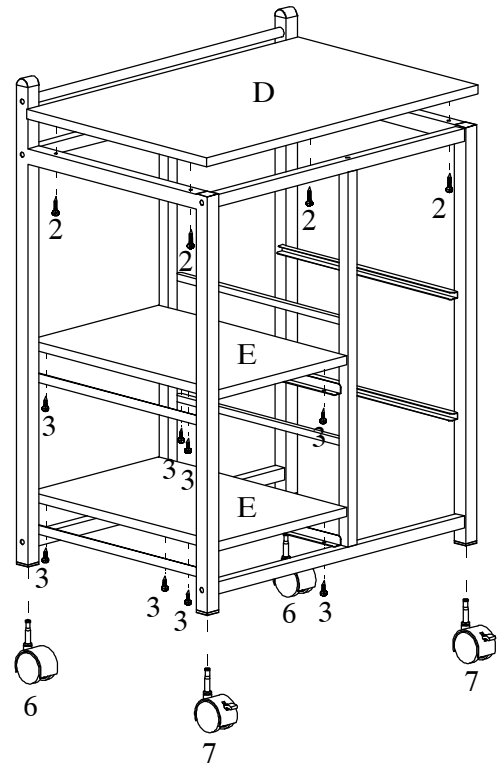

STEP 3

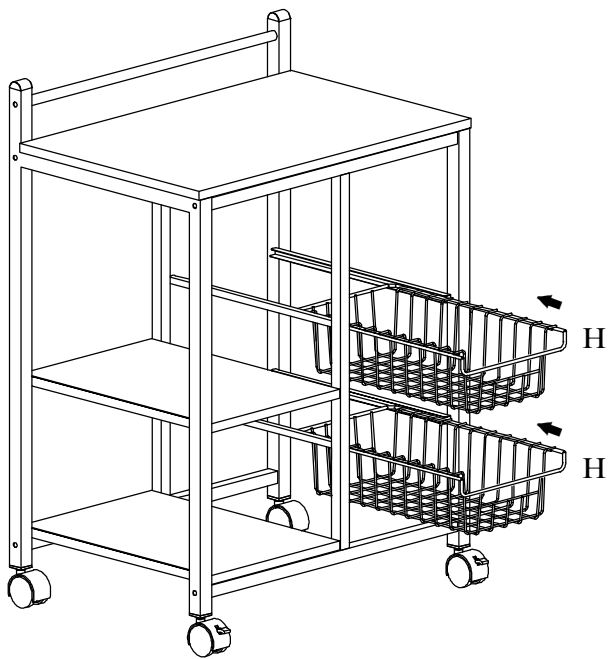

Finish Figure

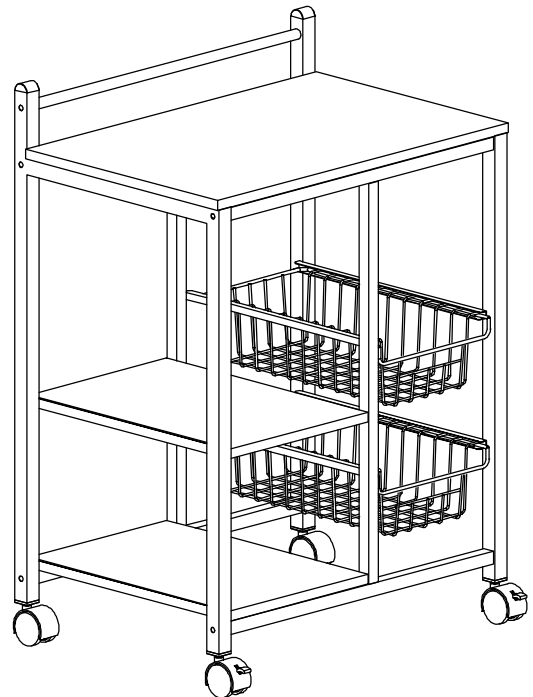

Assembly Instruction as below:

Step1: First, assemble the square tubes (F) on the two open ends of the middle side frame (B) using bolts (1). Second, assemble the middle and left side frames (B) & (A) using bolts (1). Third, assemble the right and middle side frames (C) & (B) using bolts (1). Then, insert the top caps (5) onto the tops of the left and right side frames (A) & (C), and the bottom caps (4) onto the bottoms of those side frames.

Step2: First, put the top shelf (D) on the finish portion from step 1 and fasten using large screws (2). Second, place the two shelves (E) between the left side frame (A) and middle side frame (B) and fasten using small screws (3). Third, insert the casters (6) on the back of the side frames and insert the locking casters (7) on the front side of the frames.

Step3: Slide the baskets (H) between the right side frame (C) the middle side frame (B).

Step4: Assembly completed.