

# ASSEMBLY INSTRUCTIONS

(Box 1)  
BOX OF HEADBOARD & FOOTBOARD

No	ITEM	Qty
A	Headboard	1 pc
B	Footboard	1 pc
C	Headboard Leg(L&R)	2 pcs
D	Bed Slats	4 pcs
E	Bed Slats Support	4 pcs
F	Side Rail-Right	2 pcs
G	Side Rail-Left	2 pcs
H	Bed Side Leg	2 pcs

(Box 1)  
HARDWARE LIST

No	ITEM	Qty
1	ALLEN KEY m4x65mm Blk	1 pc
2	ALLEN KEY m5x65mm Blk	1 pc
3	JCBC Bolt m6x35mm Blk	8 pcs
4	Spring Washer 1/4" Rbw	8 pcs
5	Flat Washer 1/4"IDx13mmOD Blk	8 pcs
6	Flat Head Chipboard Screw m4x32mm Rbw	12 pcs
7	Adaptor 5V1A UL Certificate	1 pc

**STEP 1 :** Remove Headboard Leg ( C ) by uncrew Flat Head Chipboard Screw(6) as shown.

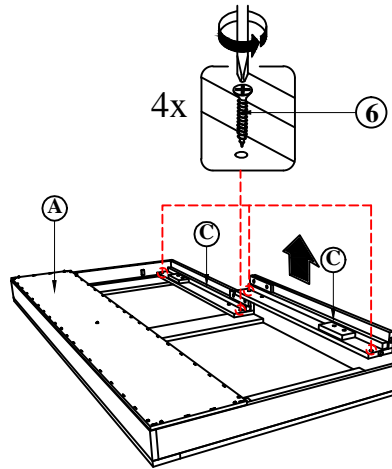

**STEP 1.1 :** Align Head Board Leg ( C ) to Head Board ( A ) by attach them to the marking stopper as shown .  
**STEP 1.2 :** Attach Head Board Leg ( C ) to Head Board ( A ) as shown using Csk Screw ( 6 ) and securing with Screw driver(NOT PROVIDED) .

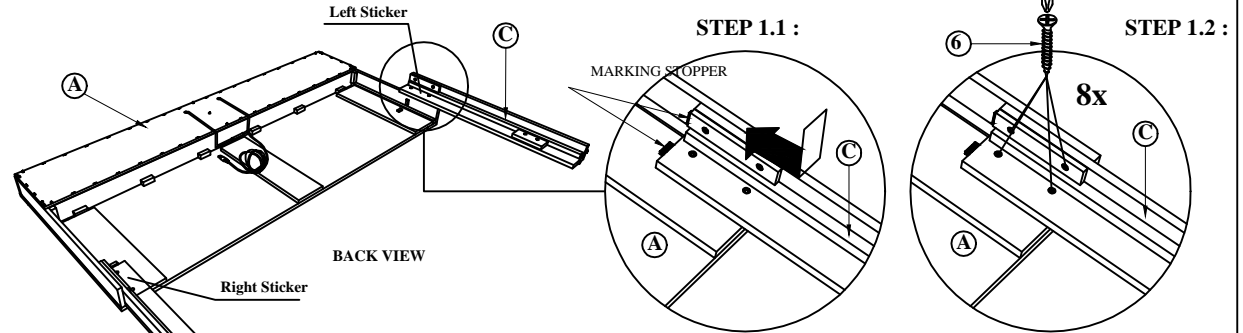

**STEP 2.1 :** Attach Side Rail ( F ) & ( G ) to the Bed Side Rail Leg ( H ) as shown using JCBC BOLT( 3 )with Spring Washer (4),Flat washer (5)and securing with ALLEN KEY ( 1 ) by outside side rail ( F ) & ( G ) .

**STEP 2.2 :** Hook SET-UPSIDE RAIL TO HEAD BOARD ( A ) closely and push down to fit. repeat step 2 with other end of rail to hook onto FOOTBOARD ( B ) .

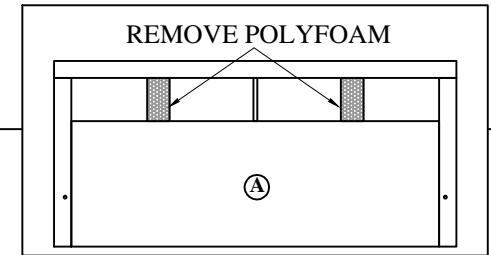

**STEP 2.1 :**

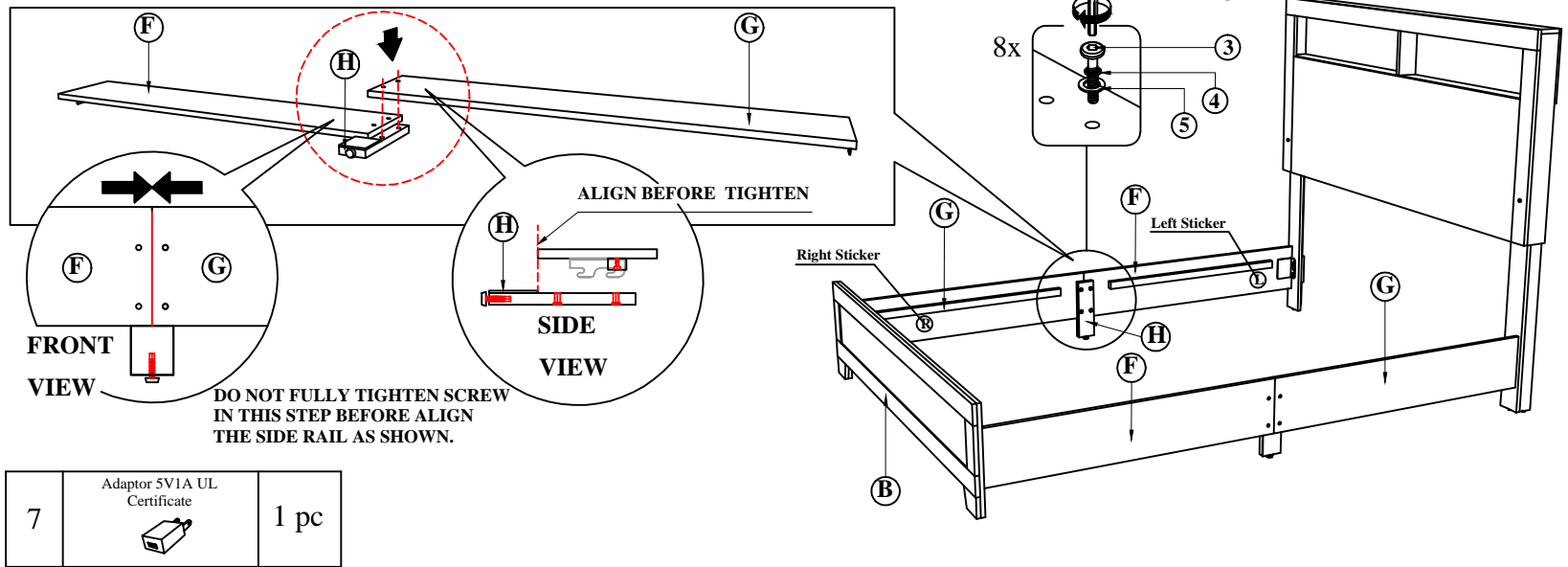

NOTE : MUST TIGHTEN SCREWS PERIODCALLY WITH USE SCREW WILL BECOME LOOSE CHECK TIGHTNESS OF ALL SCREW EVERY 6-8 WEEKS.

# ASSEMBLY INSTRUCTIONS

**STEP 3 :** Tighten the 4 Corner with Allen Key (2). Fix the Bed Slat Support Leg (E), to Bed Slat (D) as shown. Install the bed slat (D) to side rail (F) & (G) and tighten with Csk Screw (6) as per diagram shown. (NOTE: THE SETUP MUST BE DONE AT THE DECIDED LOCATION FOR THE BED TO OBTAIN PERFECT STABILITY)

**STEP 3.2 :**

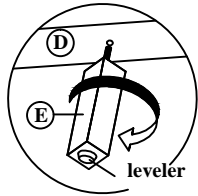

leveler

**STEP 3.3 :**

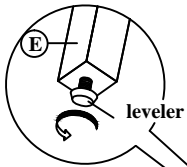

leveler

**STEP 3.1 :**

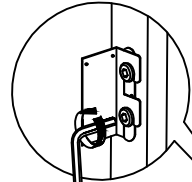

2

**STEP 3.4 :**

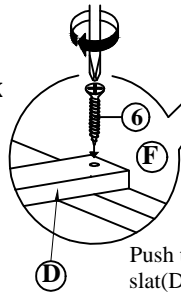

8x  
Push the side rail(F) & (G) meet with wooden slat(D) and fix the CSK screw (6) by using the Screw Driver.

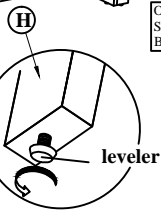

leveler

ON & OFF TOUCH SWITCH SENSOR BUTTON

**STEP 3.5 :**

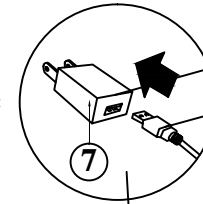

Plug into electric outlet

Plug into adaptor (3)

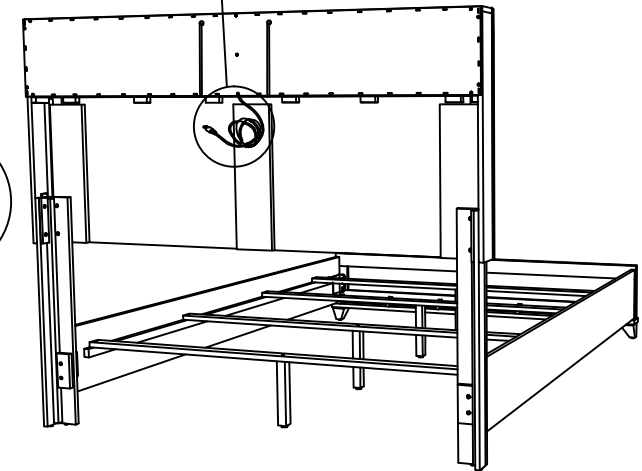

BACK VIEW

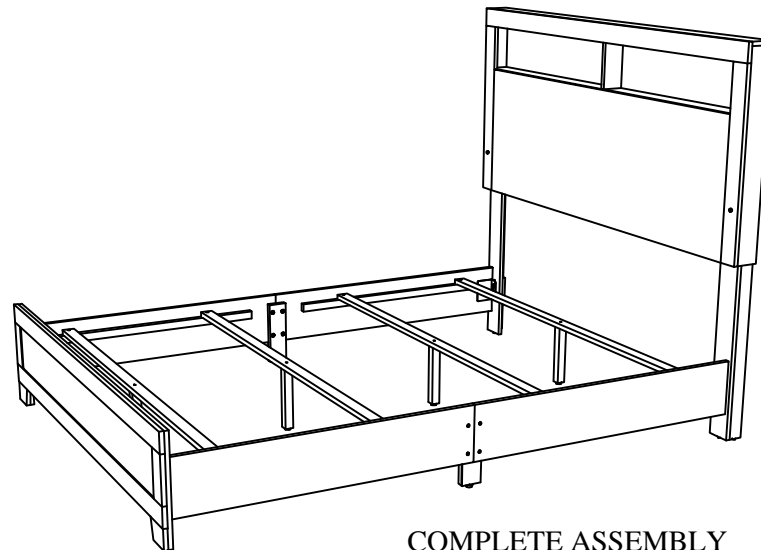

COMPLETE ASSEMBLY