

ASSEMBLY INSTRUCTIONS

VIRGINIA CROSS BACK CHAIR ITEM

ASSEMBLY
REQUIREMENTS:

1-Person
Assembly

30 MINUTES
Assembly Time
Per Chair
(Approximate)

Tools Required:
(Not Provided)

Phillips
Screwdriver

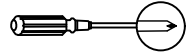

Thank you for purchasing our product!

Please refer and use this assembly instruction to assemble the product. Contact our customer service department in case there are any missing or damage parts or hardware. Replacement parts are normally shipped within 2 or 3 days.

PRODUCTS PURCHASED THROUGH OUR AUTHORIZED VENDORS ONLY ARE ELIGIBLE FOR REPLACEMENT PARTS.

We appreciate your business!

**THIS PRODUCT IS FOR INDOOR AND HOUSEHOLD USE ONLY
- NOT FOR COMMERCIAL USE.**

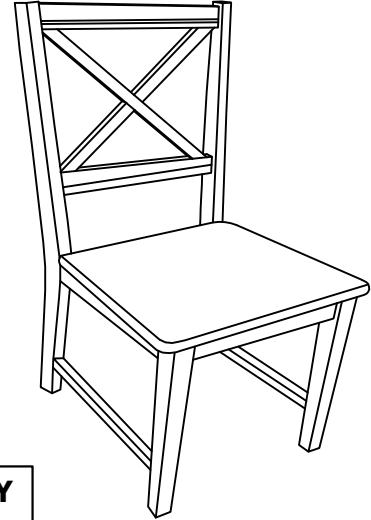

ASSEMBLY PREPARATION

1. Remove all packaging materials, staples and packing straps from the carton.
2. Refer to Parts List and Hardware List and ensure they are complete before you start assembling.
3. Place all wooden parts on a clean, flat and soft surface (e.g. carpet or rug) to prevent parts from getting scratched.

SAFETY PRECAUTION:

1. KEEP ALL HARDWARE PARTS OUT OF REACH OF CHILDREN.
2. DISPOSE PLASTIC PACKAGING MATERIAL IMMEDIATELY TO AVOID ANY RISK OF SUFFOCATION TO CHILDREN AND ANIMALS.

TIPS FOR ASSEMBLY:

1. Allow ample room for assembly and in close proximity to where product will be placed.
2. Assemble the product on a surface that does not scratch or damage the exterior gloss and finish of the furniture.
3. Please check all of the parts and quantities are included before assembly. Contact customer service for missing parts.
4. Identify all of the parts, hardware and quantities required for each step.
5. During assembly, do not over-tighten any fittings as this may cause damage.
6. DO NOT USE POWER TOOLS TO ASSEMBLE THIS PRODUCT.
7. Always place the product on a flat surface.
8. Do not sit or stand on the partially assembled product; only use the product for which it is intended.

CARE AND MAINTENANCE







- Wipe clean with a soft, dry cloth; avoid the use of harsh chemicals or household cleaners as they may damage the exterior finish of the furniture.
- **Hardware may loosen over time. Periodically, check that all connections are tight; re-tighten as necessary.**
- Solid wood is impacted by heat and humidity fluctuations and may result in small joint separations or hairline cracks; place the furniture away from direct sunlight and air conditioning vents, heating vents or units to protect the furniture.

ASSEMBLY INSTRUCTIONS VIRGINIA CROSS BACK CHAIR ITEM

Parts List (For 1 Nos . Of Chair)

NO	PARTS LIST	QTY
1	CHAIR BACK	1
2	FRONT LEG	1
3	WOODEN SEAT	1
4	SIDE RAIL (FL/FR)	2
5	SIDE LOWER RAIL (FL/FR)	2

Hardware List (For 1 Nos . Of Chair)

NO	Description	PART	QTY	Extra
A	JCBC BOLT M6 x 50mm		8	1
B	SPRING WASHER		8	1
C	FLAT WASHER		8	1
D	CSK SCREW M4 x 38mm		4	1
E	CSK SCREW M4 x 32mm		3	1
F	ALLEN KEY		1	
G	NAIL LEG			2

*Extra Hardware For Spare Use.

STEP 1

Attach Left and Right Side Rail (4) with the labels FL and FR towards the Front Leg (2) as shown. Fasten with JCBC Bolt (A) fitted with Spring Washer (B) and Flat Washer (C) using Allen Key (F).
Do not tighten completely at this time.

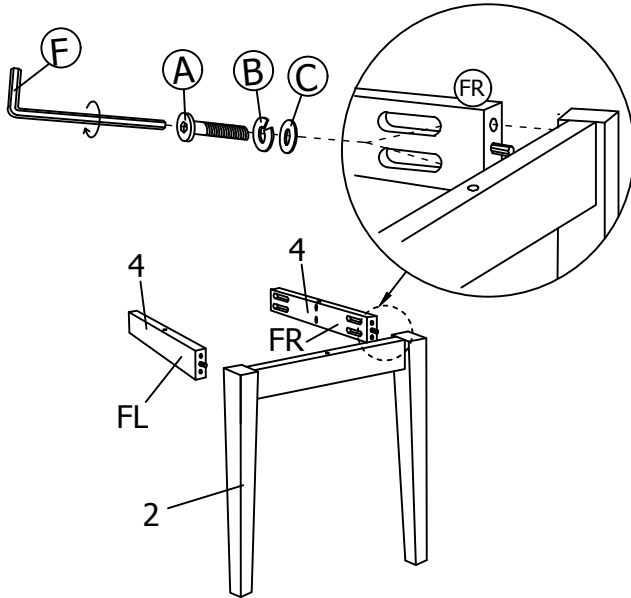

STEP 2

Attach the Left and Right Side Lower Rail (5) - with the pre-drilled screw-holes faced down - to the Front Leg and Side Rail subassembly completed in Step 1.

Remark : The label FL and FR on (5) to be toward the Front Leg (4). Next, insert the other ends of the Side Rail and Stretcher to the Chair Back (1). Fasten Side Rail to Chair Back with JCBC Bolt (A) fitted with Spring Washer (B) and Flat Washer (C) using Allen Key (F). Do not tighten completely until all 4x (A) are in place.

Tighten JCBC Bolt (A) in Step 1 completely.

Do not over-tighten. Do not use power tools.

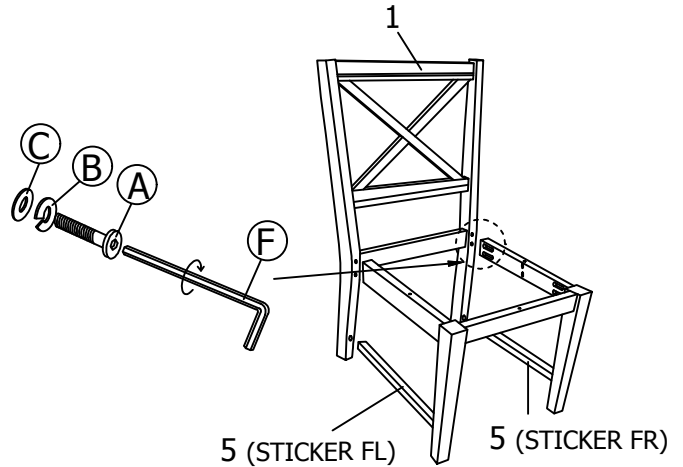

STEP 3

Step 3 - 1

Position the chair frame assembly with the legs facing up as shown. Use Screw (D) to fasten the Left and Right Side Lower Rail (5) to the legs with a Phillips Screwdriver (Not Provided).

Step 3 - 2

Place the Wooden Seat (3) bottom-side up. Center the seat frame to the Wooden Seat with rear of the seat against the Chair Back. Use Screw (E) to fasten the Wooden Seat to the seat frame.

The assembly of the chair is complete.

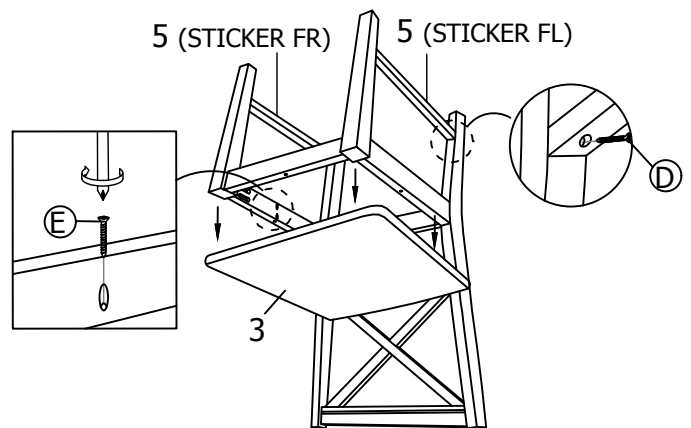

There are No Pre-Drilled holes to attach the seat