

# Murphy Bed

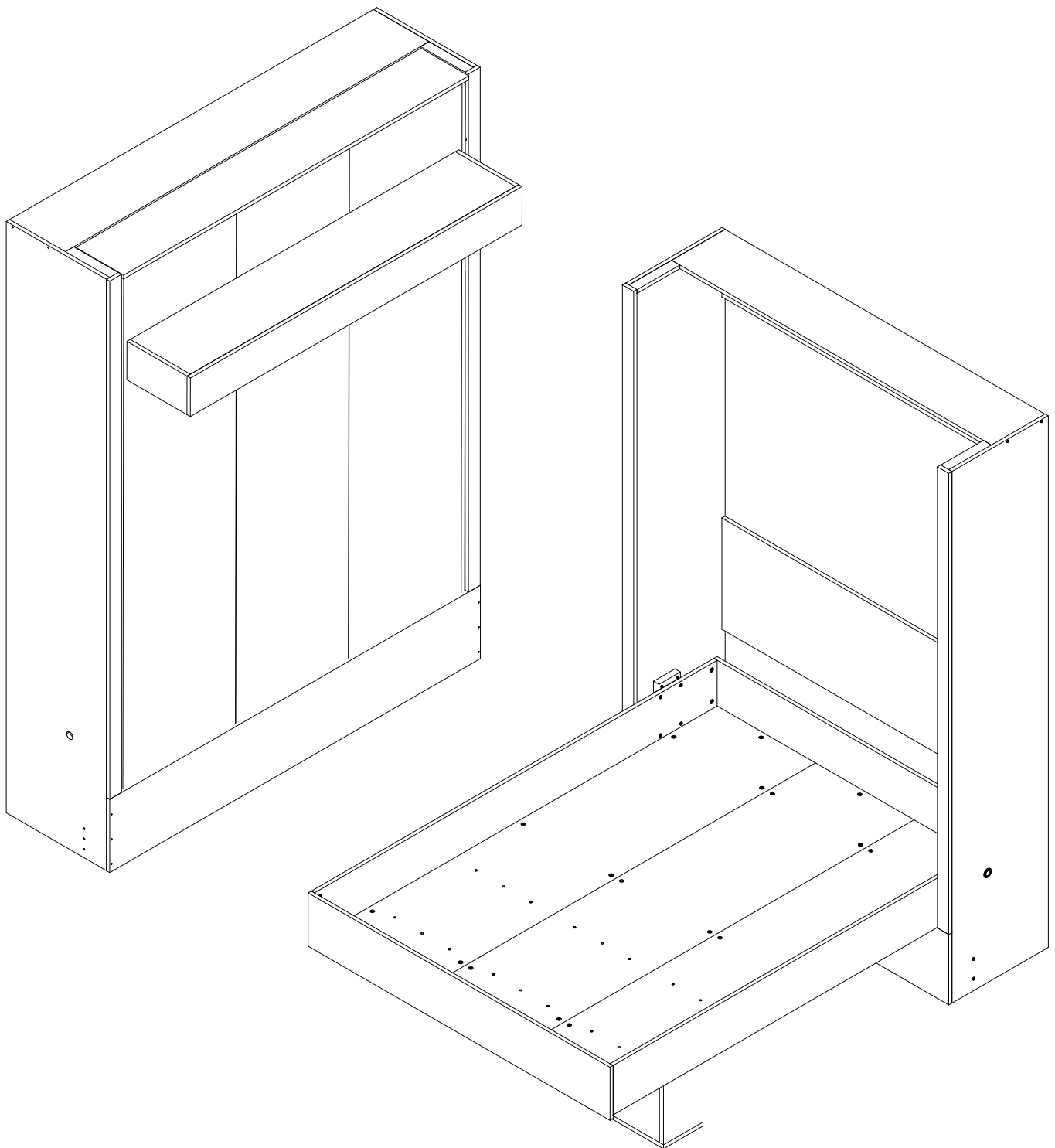

## **WARNING:**

### **WARNING FOR YOUNG CHILDREN**

i -This product contains small components, please ensure that they are kept away from small children

ii. Children under the age of 6, small infants and babies must not sleep on this bed for safety reasons. To prevent injury and damage to this unit, PROHIBIT jumping on it. \* This product is designed for home use and not intended for commercial use.

iii. We highly recommend having a professional assemble your product. Please follow each step in the correct order for a successful product assembly.

iv. Unit can tip over causing severe injury or death if not anchored correctly. - Anchor unit to studs in wall (if instructed to). - Do Not allow children to climb on unit.

V. Gas piston mechanism is set for the weight of the bed including the mattress. Please make sure to place mattress inside for a correct functioning.

## **ADVERTENCIA:**

### **ADVERTENCIA PARA NIÑOS PEQUEÑOS**

i - Este producto contiene componentes pequeños, por favor, asegúrese de mantenerlos fuera del alcance de los niños.

ii. Los niños menores de 6 años, los lactantes pequeños y los bebés no deben dormir en esta cama por razones de seguridad. Para evitar lesiones y daños a esta unidad, PROHÍBASE saltar sobre ella. \*Este producto está diseñado para uso doméstico y no para uso comercial.

iii. Recomendamos encarecidamente que su producto sea montado por un profesional. Por favor seguir cada paso en el orden correcto para obtener una instalación exitosa.

iv. La unidad puede volcarse causando lesiones graves o la muerte si no se ancla correctamente. - Ancla la unidad a la pared - No permita que los niños se suban a la unidad.

v. El mecanismo con pistón a gas considera el peso del producto incluyendo el peso del colchón. Por favor colocar el colchón dentro para un correcto funcionamiento.

## Summary Resumen

<b>Introduction</b> Introducción	.....	3
<b>Before starting</b> Antes de comenzar	.....	4
<b>Avoid accidents</b> Evitar accidentes	.....	4
<b>Dimensions and tools</b> Dimensiones y herramientas	.....	5
<b>Identifying parts</b> Identificación de las piezas	.....	6
<b>Hardware included in box</b> Accesorios incluidos en la caja	.....	7
<b>Furniture assembly</b> Montaje del mueble	.....	8

## Introduction Introducción

Read this manual and follow the steps in order to for a correct and safe installation.  
Not doing so can result in damage to parts and injury to users.

Lea este manual y siga los pasos para que el producto sea correctamente instalado.  
No realizar el montaje como se indica puede resultar en rotura de piezas y daño a los usuarios.

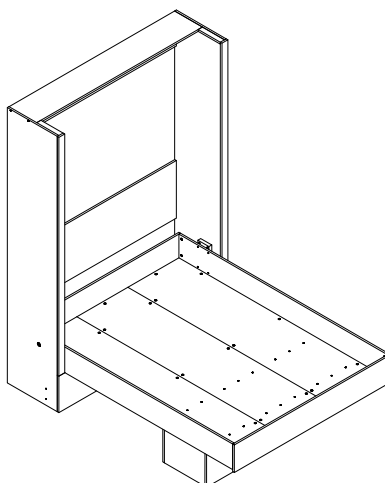

## Before starting Antes de comenzar

**Prepare the room before starting the assembly, leaving it completely clean and the area in good condition to start the work.**

Antes de comenzar el montaje prepare el ambiente, dejándolo completamente limpio y con buen espacio para comenzar el trabajo.

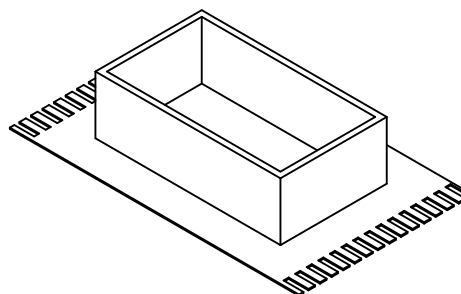
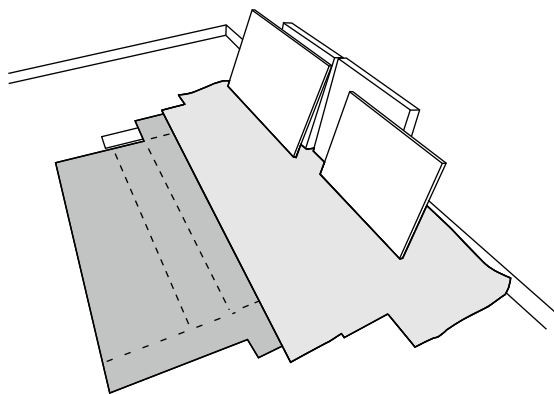

**Use the cardboard from the packaging to separate and support the parts once they have been taken out of the box.**

Utilice el cartón del embalaje para separar y apoyar las piezas una vez retiradas de las cajas.

**Cover the assembly area with a blanket or carpet to avoid damaging the parts during the assembly process.**

Cubrir la zona de montaje con una manta o alfombra para evitar daños en las piezas durante el proceso de montaje.

---

**All the furniture parts have been marked with a number. Before you start assembling, please identify the numbered parts in relation to the assembly instructions. Once assembly is completed, the numbers can be easily removed with a cloth slightly dampened in alcohol. Use alcohol only to remove part numbers.**

Todos las piezas del mueble fueron marcadas con un número. Antes de empezar el montaje, identifique las piezas numeradas en relación con las instrucciones de montaje. Una vez que se completa el armado, los números se pueden quitar fácilmente con un paño ligeramente empapado en alcohol. Use alcohol solo para eliminar números de las piezas.

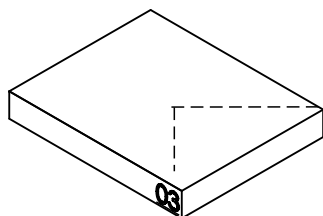

**USE ALCOHOL ONLY TO REMOVE PART NUMBERS  
UTILICE ALCOHOL SOLAMENTE PARA ELIMINAR EL NUMERO DE LAS PIEZAS**

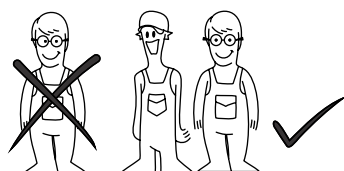

**Assembly must be done by two people.**  
Montaje debe ser realizado por dos personas.

To speed assembly, use an electronic screwdriver.  
Para facilitar el armado, utilice un destornillador eléctrico.

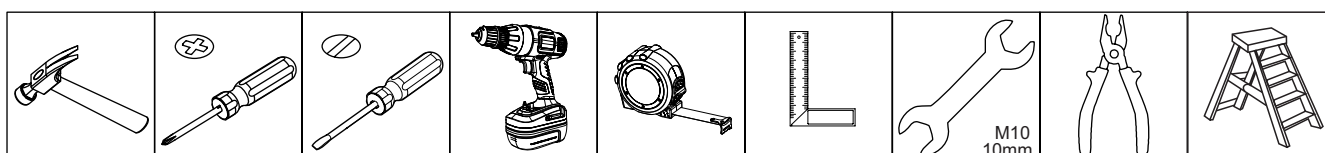

## Dimensions and tools Dimensiones y herramientas

Dimensions:  
W: 65.51 H: 90.55 D: 84.64 inches  
Dimensiones:  
L: 1664 A: 2300 P: 2150 mm

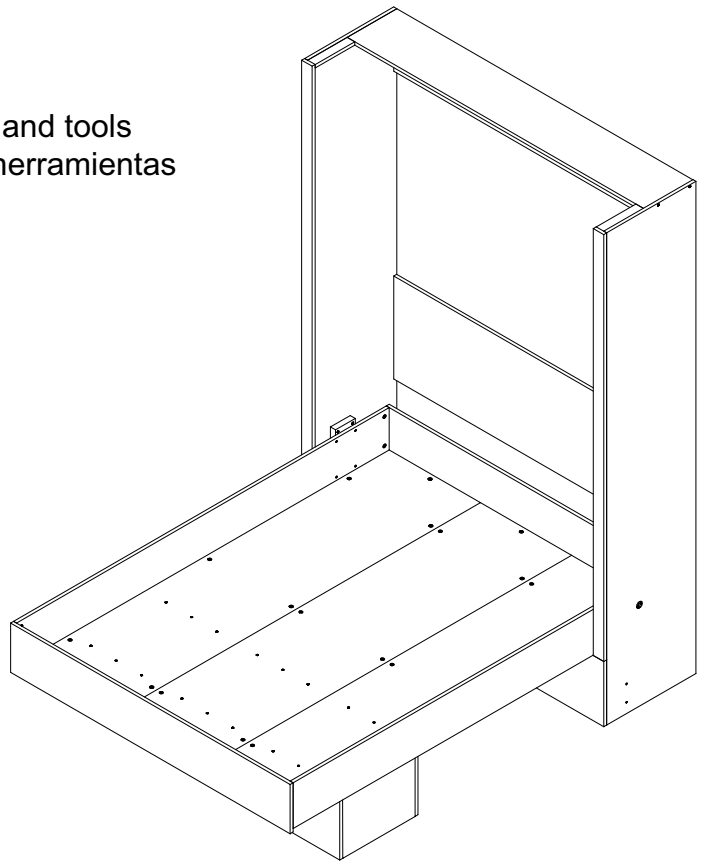

## Avoid accidents Prevenir accidentes

**You are requested to carefully observe and follow assembly instructions in the correct order. Operating the up and down function without first securing the bed to a wall and installing a mattress could lead to risk of injury.**

Bed frame **MUST BE FIXED** to the wall before installing gas piston mechanism for a safe and successful installation.

Place mattress inside when closing the bed for the first time after assembly is complete.

Gas pistons are set for the weight of this product + the weight of the mattress to function properly.

Safely guide bed closed if there is no mattress inside to avoid pistons snapping when closing.

Unpacking and assembly must be done by two people.

Do not climb or lean on the furniture. Use a ladder for assembly of higher parts.

Respect weight limit shown for this product.



**Se debe observar y seguir las instrucciones de montaje en el orden correcto.**

**Abrir y cerrar la cama sin fijar la cama antes a la pared o sin colocar el colchón dentro puede ocasionar riesgo de lesión.**

El marco de la cama debe fijarse a la pared antes de colocar el mecanismo de piston a gas para una segura instalación.

Favor colocar el colchón dentro antes de cerrar el producto por primera vez luego de finalizar la instalación.

La fuerza de los pistones a gas considera el peso del producto junto con el peso del colchon para funcionar correctamente.

Guiar la cama con cuidado al cerrar si no hay colchón dentro, para así evitar un cierre fuerte.

Desempaque y montaje debe ser realizado por dos personas.









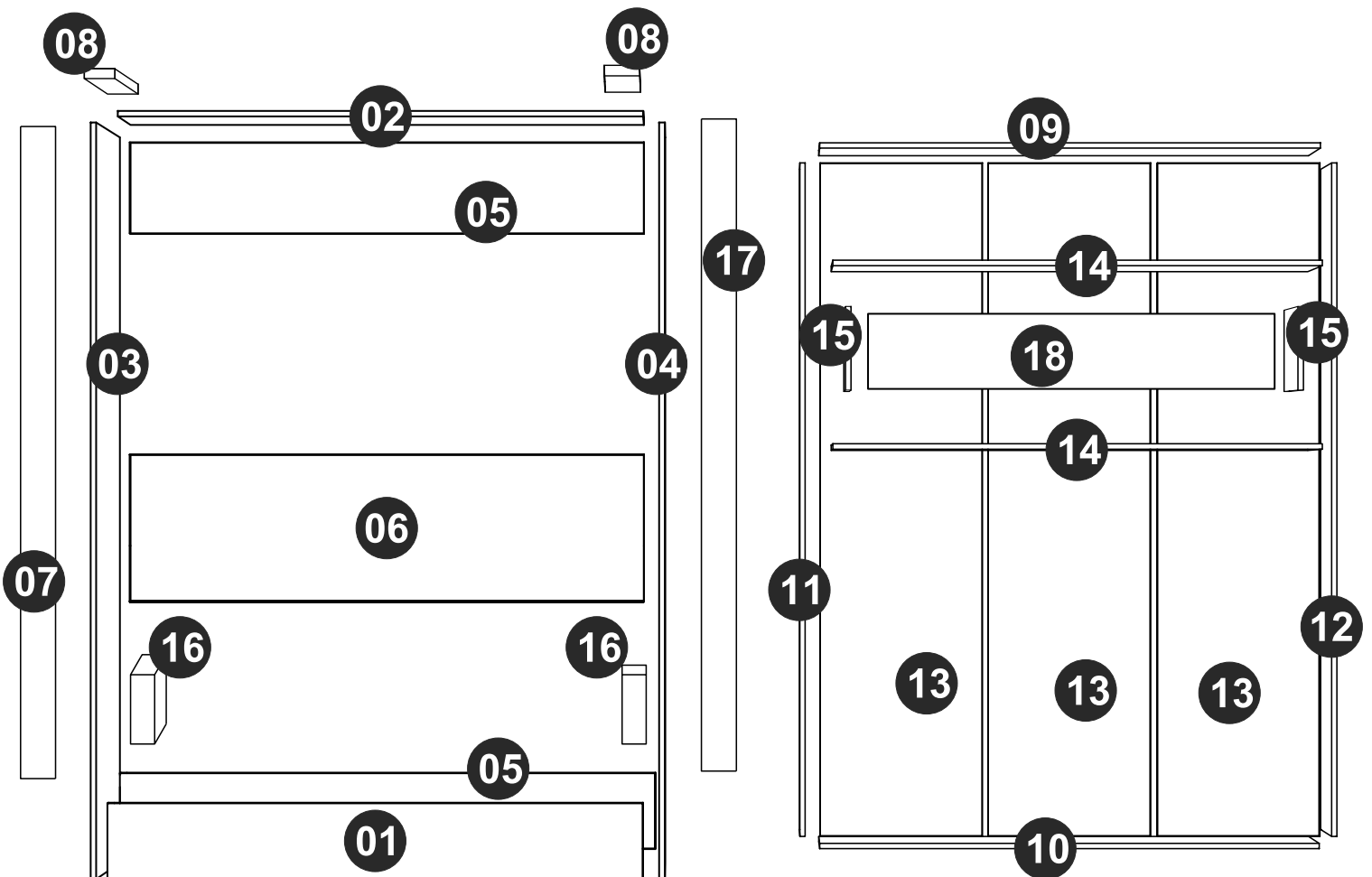



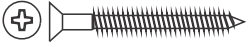

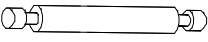
No se apoye ni trepe al mueble. Para el montaje de las partes superiores se recomienda el uso de escalera.

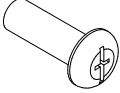
Por favor respetar el maximo de peso soportado por el producto.

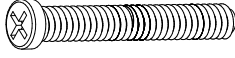
PART	DESCRIPTION	QTY.
001	BASE	1
002	TOP	1
003	LEFT SIDE	1
004	RIGHT SIDE	1
005	TRAVERSE	2
006	BACK	1
007	LEFT DETAIL	1
008	UPPER DETAIL	2
009	TOP BED	1
010	BASE BED	1
011	LEFT SIDE BED	1
012	RIGHT SIDE BED	1
013	BOTTOM BED	3
014	NICHE SHELF	2
015	NICHE SIDE	2
016	REINFORCEMENT	2
017	RIGHT DETAIL	1
018	NICHE TOP	1

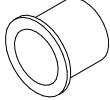
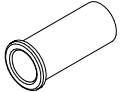
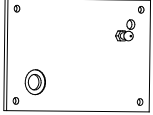
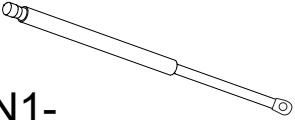
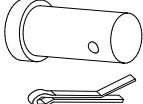
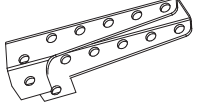
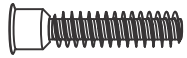
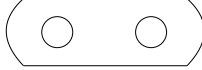
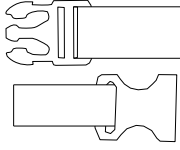
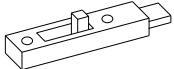

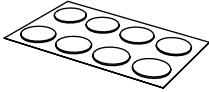
PIEZA	DESCRIPCIÓN	CANTIDAD
001	BASE	1
002	TAPA	1
003	LATERAL IZQUIERDA	1
004	LATERAL DERECHA	1
005	TRAVESAÑO	2
006	REVÉS	1
007	DETALLE IZQUIERDO	1
008	DETALLE SUPERIOR	2
009	TAPA CAMA	1
010	BASE CAMA	1
011	LATERAL IZQUIERDA CAMA	1
012	LATERAL DERECHA CAMA	1
013	FONDO CAMA	3
014	REPISA NICHOS	2
015	LATERAL NICHOS	2
016	REFORZAMIENTO	2
017	DETALLE DERECHO	1
018	TAPA NICHOS	1

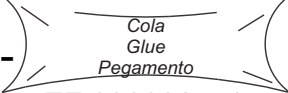

- A-  EF 000033 x 74  
8x30
- B-  EF 000094 X 60
- C-  EF 000858 X 72
- D-  EF 000129 x 8  
4X35 CC
- E-  EF 000132 x 22  
4x50 CC
- F-  EF 000751 X 6
- G-  EF 000724 X 4  
8x40
- H1-  EF 000855 X 8  
4x14 CF
- H2-  EF 000856 X 8  
M4x12 CF
- I-  EF 000833 X 6  
M6x50 CP
- J-  EF 000083 X 6
- K-  06.18 X 2
- L-  06.18 X 2
- M-  06.18 X 2
- N1-  06.18 X 2
- N2-  06.18 X 2
- N3-  06.18 X 2
- O-  06.18 X 2
- P-  EF 000846 x 2
- Q-  12.01.001001 X 1
- R-  12.01.001002 X 2
- S-  EF 000850 X 8  
3,0x14 CC ZP
- Z-  STICKER x 95  
TAPA HUECOS x 95
- Y-  CHALK x 01  
TIZA x 01

- AA-  Cola  
Glue  
Pegamento  
EF 000008 x 1

HARDWARE WALL FIXING - ACCESORIOS DE FIJACIÓN A LA PARED

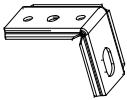
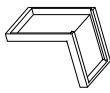
- T-  EF 000248 X 18  
3,5X14 CP
- U-  EF 000016 X 6
- V-  EF 000853 x 6  
5X50 CF
- W-  EF 000853 x 4
- X-  PLASTIC COVER x 6  
CAPA PLÁSTICA x 6



= 180 KG - 396.83 LB



= 10 KG - 22.04 LB

Tamanho Cama/Bed Size/Tamaño Cama

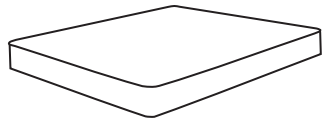

= 1520mm X 2030mm

= **6-14 inches thick, 60 X 80 inches, no futons**

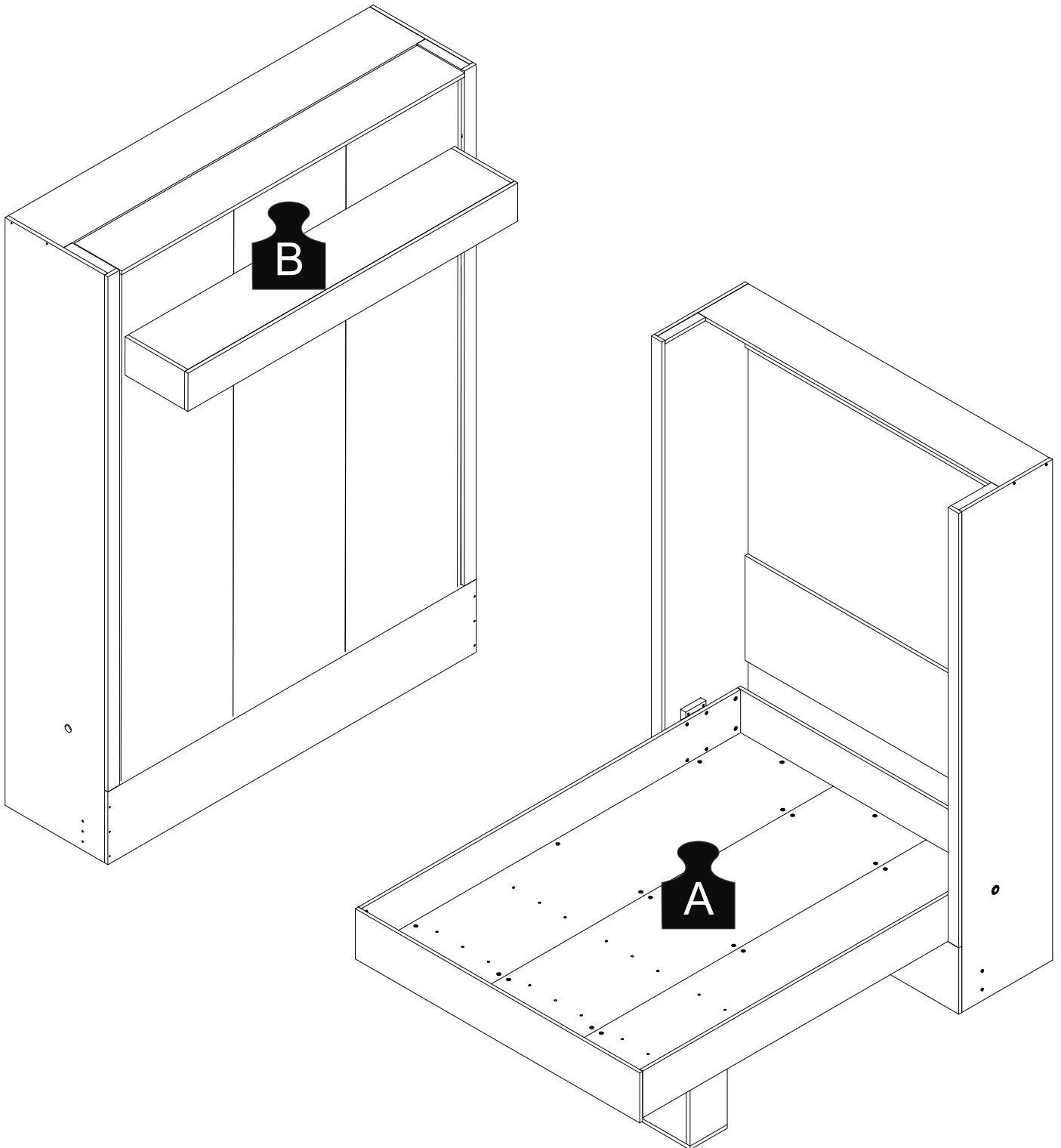

1

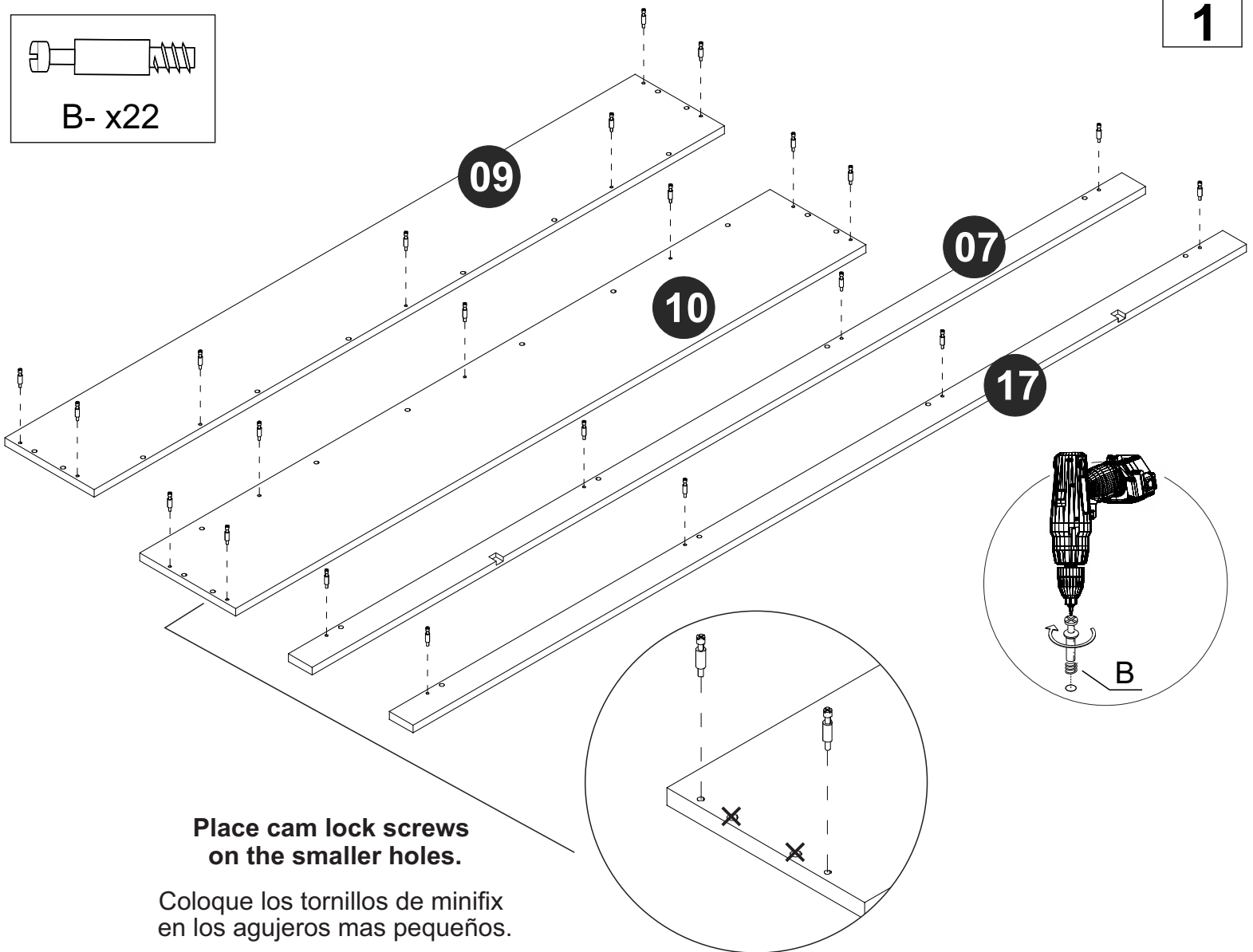
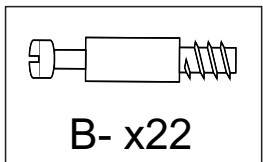

Place cam lock screws  
on the smaller holes.

Coloque los tornillos de minifix  
en los agujeros mas pequeños.

2

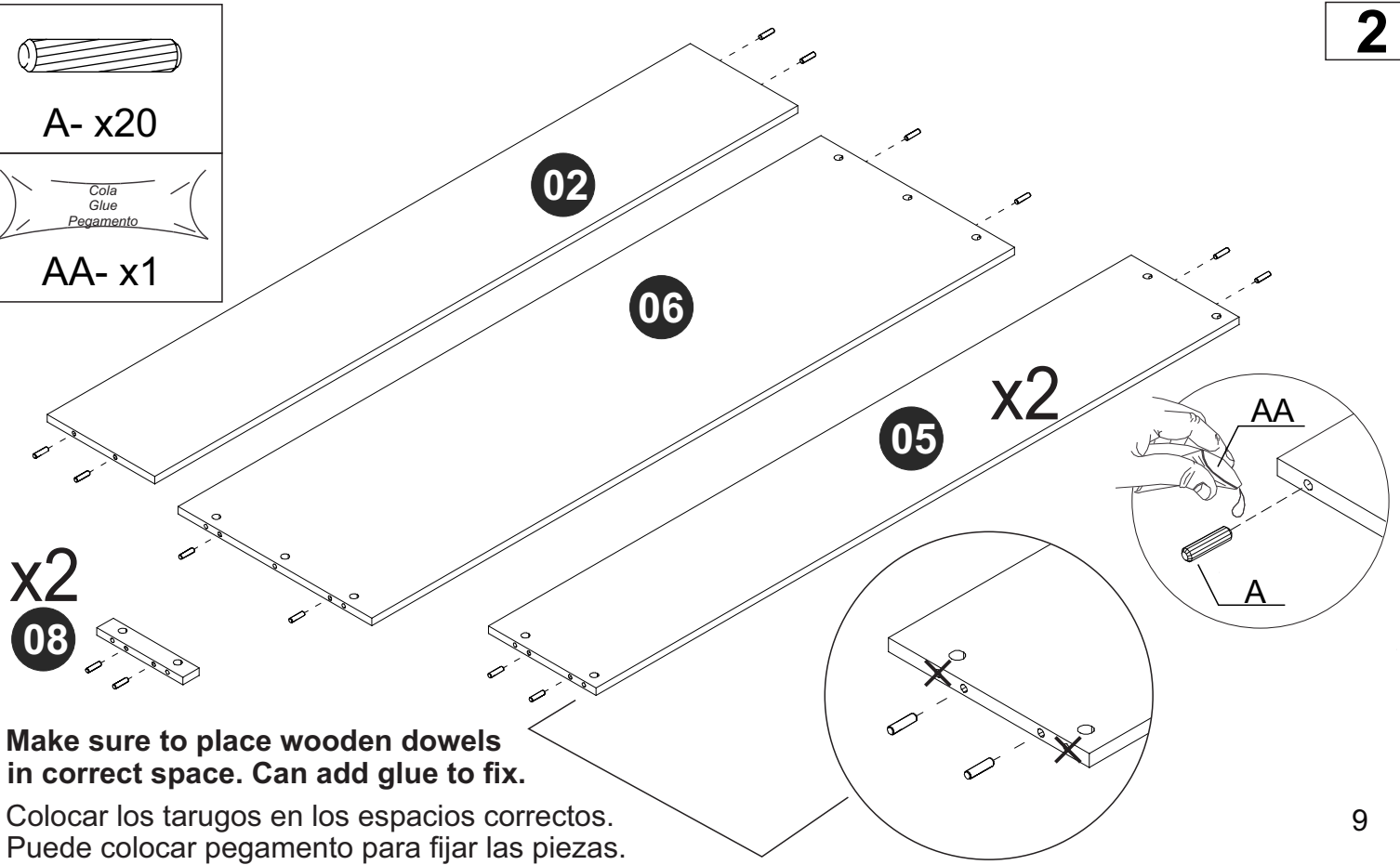
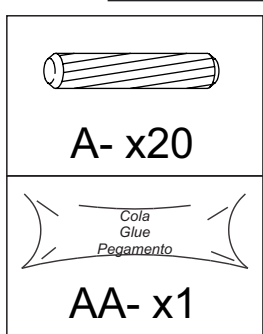

Make sure to place wooden dowels  
in correct space. Can add glue to fix.

Colocar los tarugos en los espacios correctos.  
Puede colocar pegamento para fijar las piezas.

Make sure to place wooden dowels in correct space. Can add glue to fix.

Colocar los tarugos en los espacios correctos. Puede colocar pegamento para fijar las piezas.

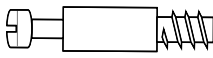
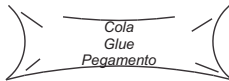

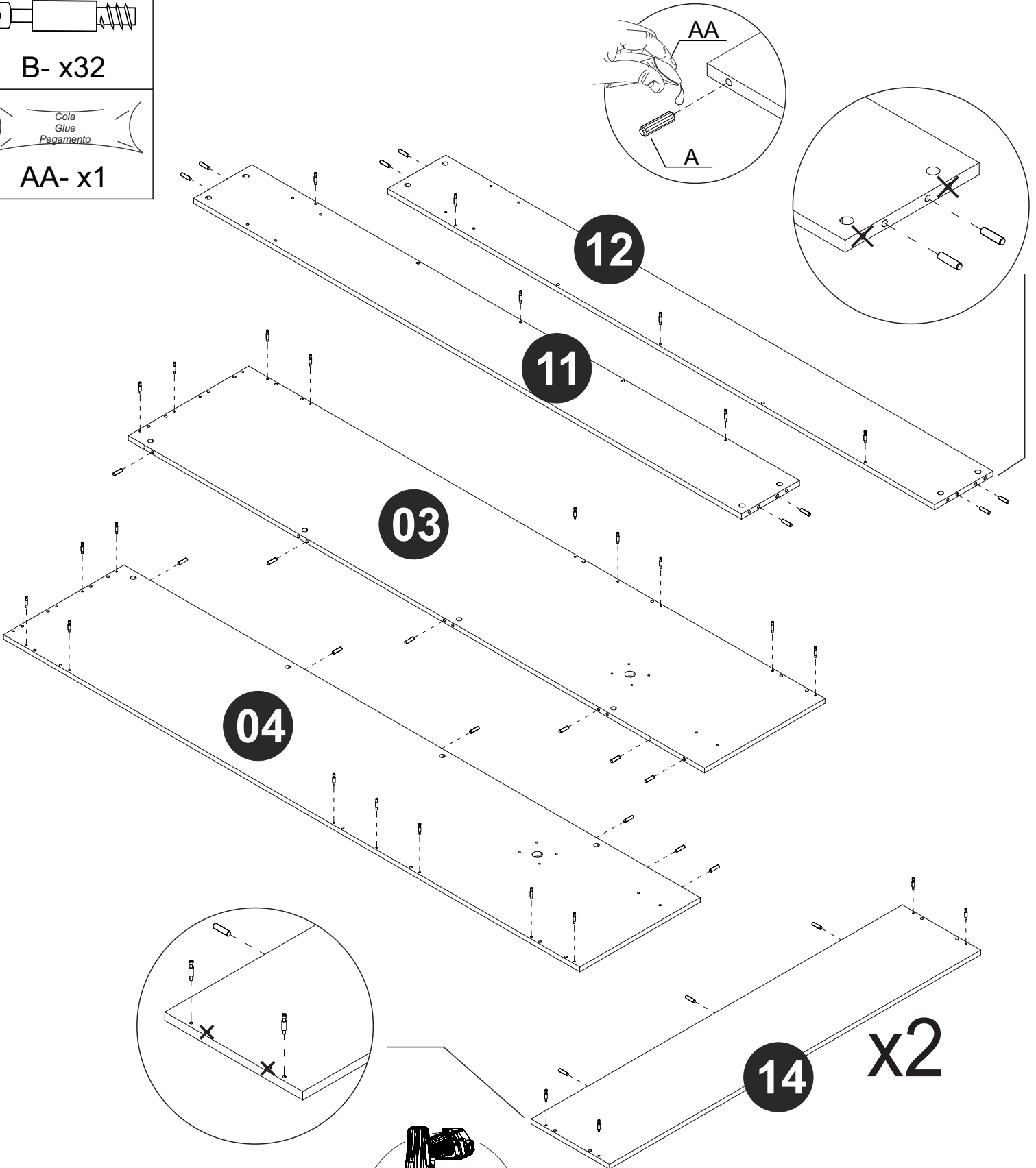
A- x26

B- x32

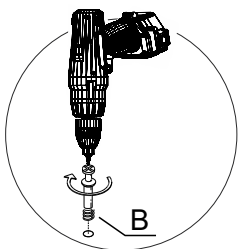
AA- x1

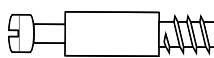
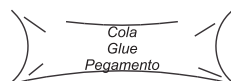

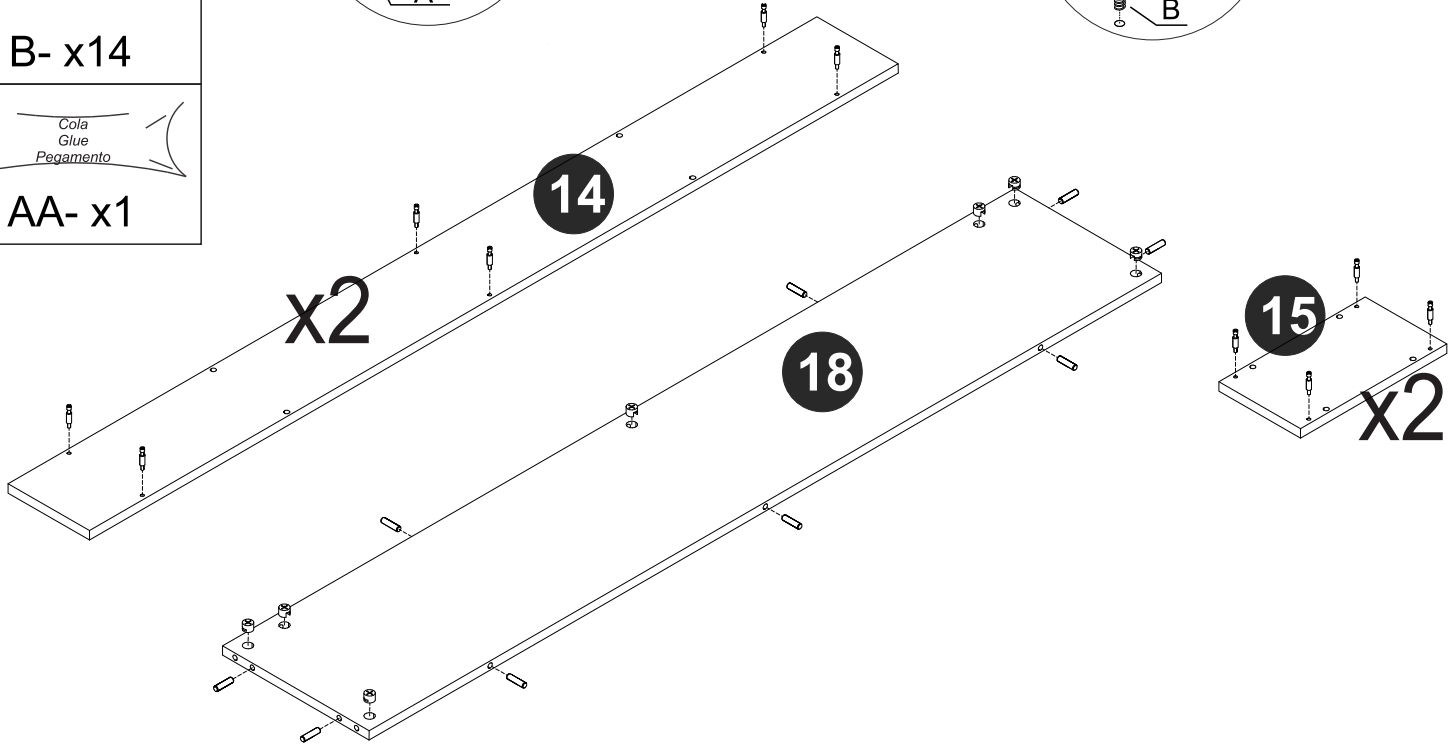
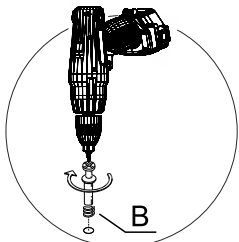
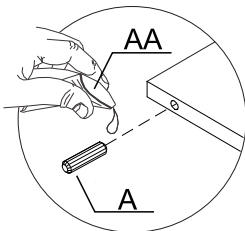
**Place cam lock screws on the smaller holes.**  
 Coloque los tornillos de minifix en los agujeros mas pequeños.



-   
A- x18
-   
B- x14
-   
Cola  
Glue  
Pegamento  
AA- x1



-   
D- x8

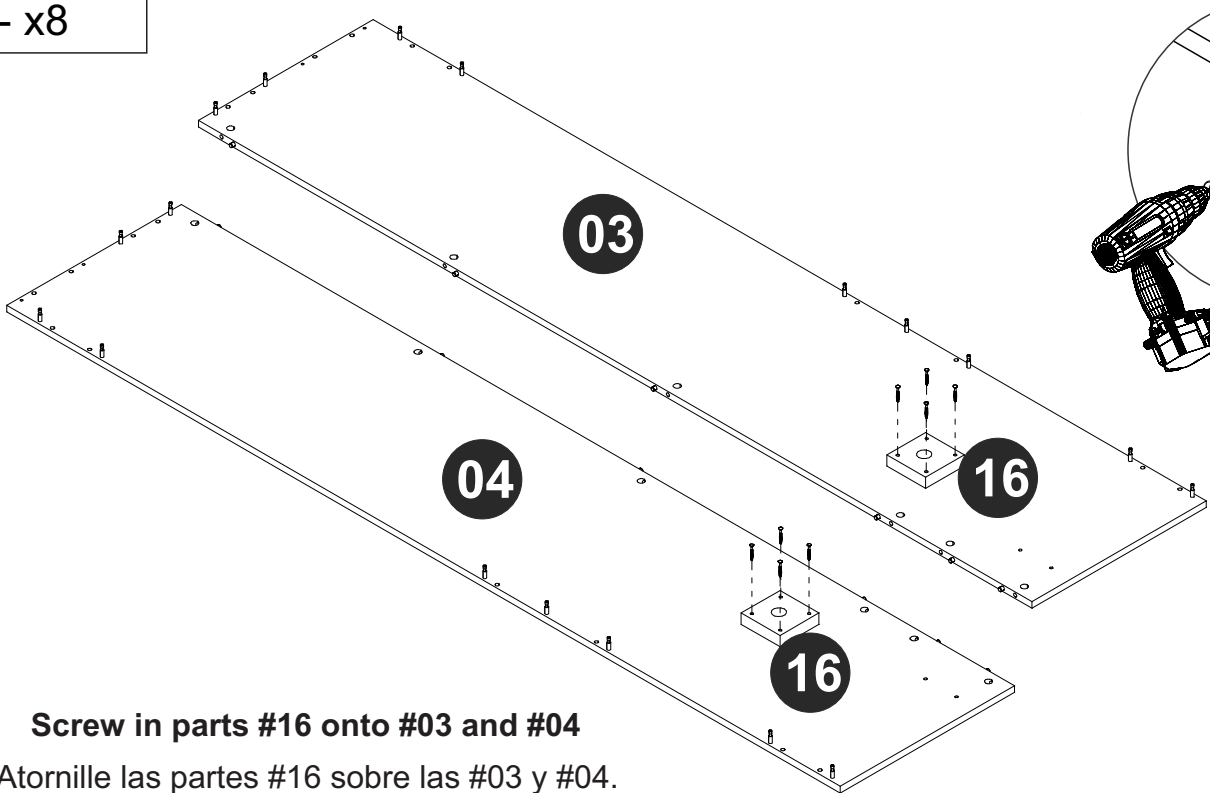
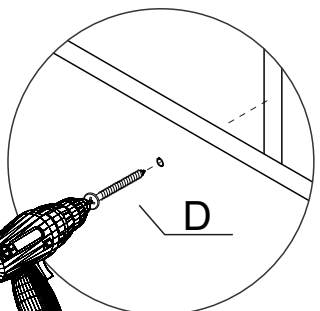

**Screw in parts #16 onto #03 and #04**  
 Atornille las partes #16 sobre las #03 y #04.

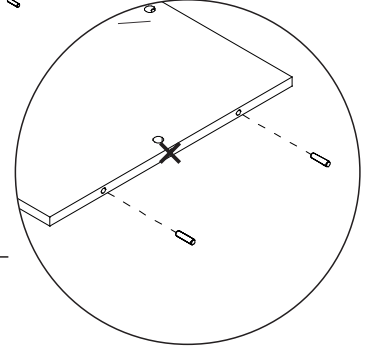
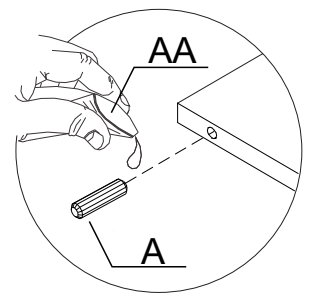
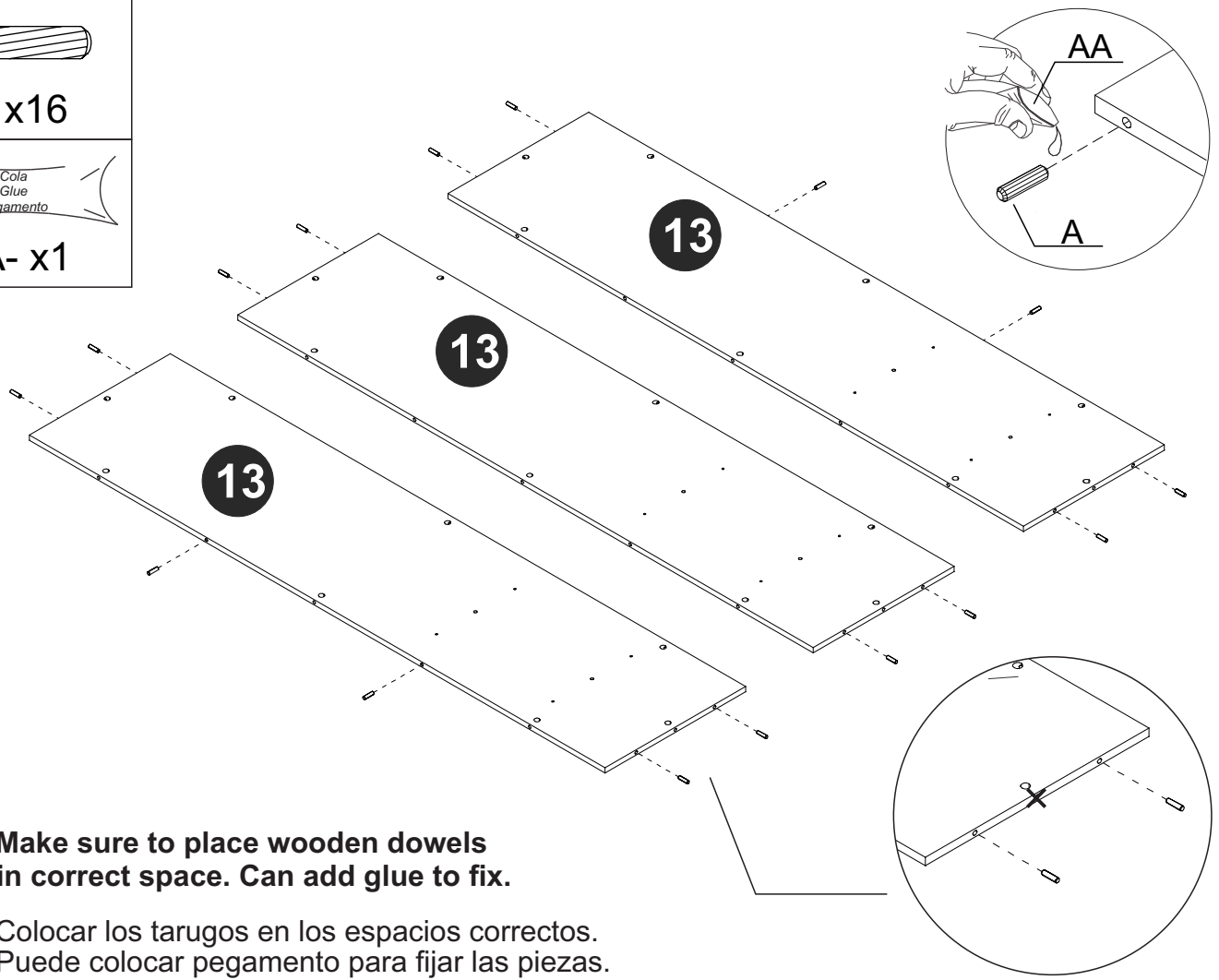
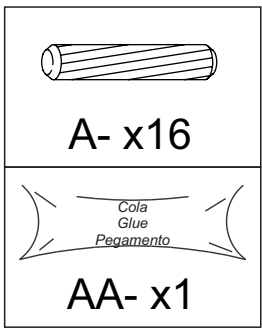

**Make sure to place wooden dowels in correct space. Can add glue to fix.**

Colocar los tarugos en los espacios correctos. Puede colocar pegamento para fijar las piezas.

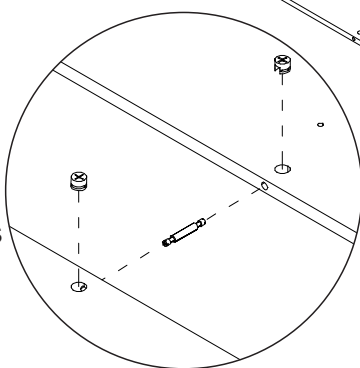
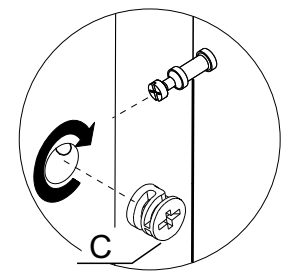
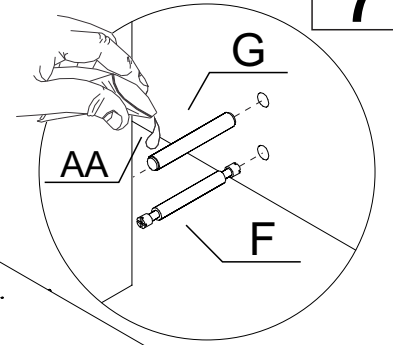
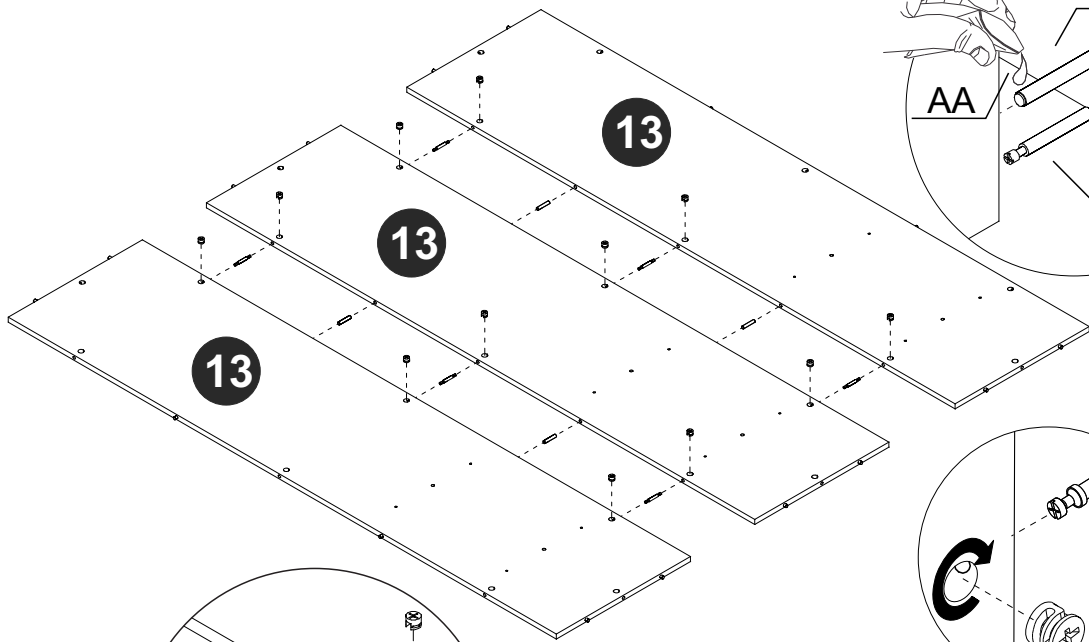
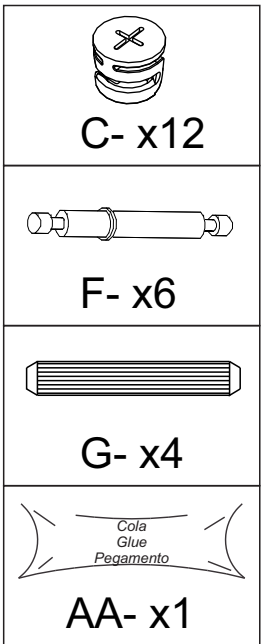

**Use double sided cam screws to attach parts 13**

Coloque los tornillos dobles para unir las partes 13

**Place cam locks. Make sure arrow is facing outwards. Once parts are attached, turn cam lock to the right using screwdriver.**

Coloque los tambores de minifix. Asegurese que las flechas indiquen hacia afuera. Una vez que las piezas se unan, gire el tambor hacia la derecha. 12

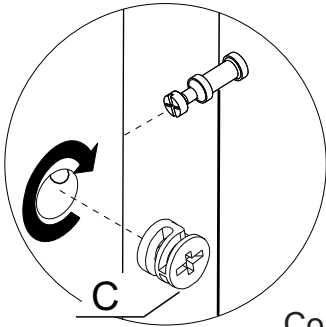
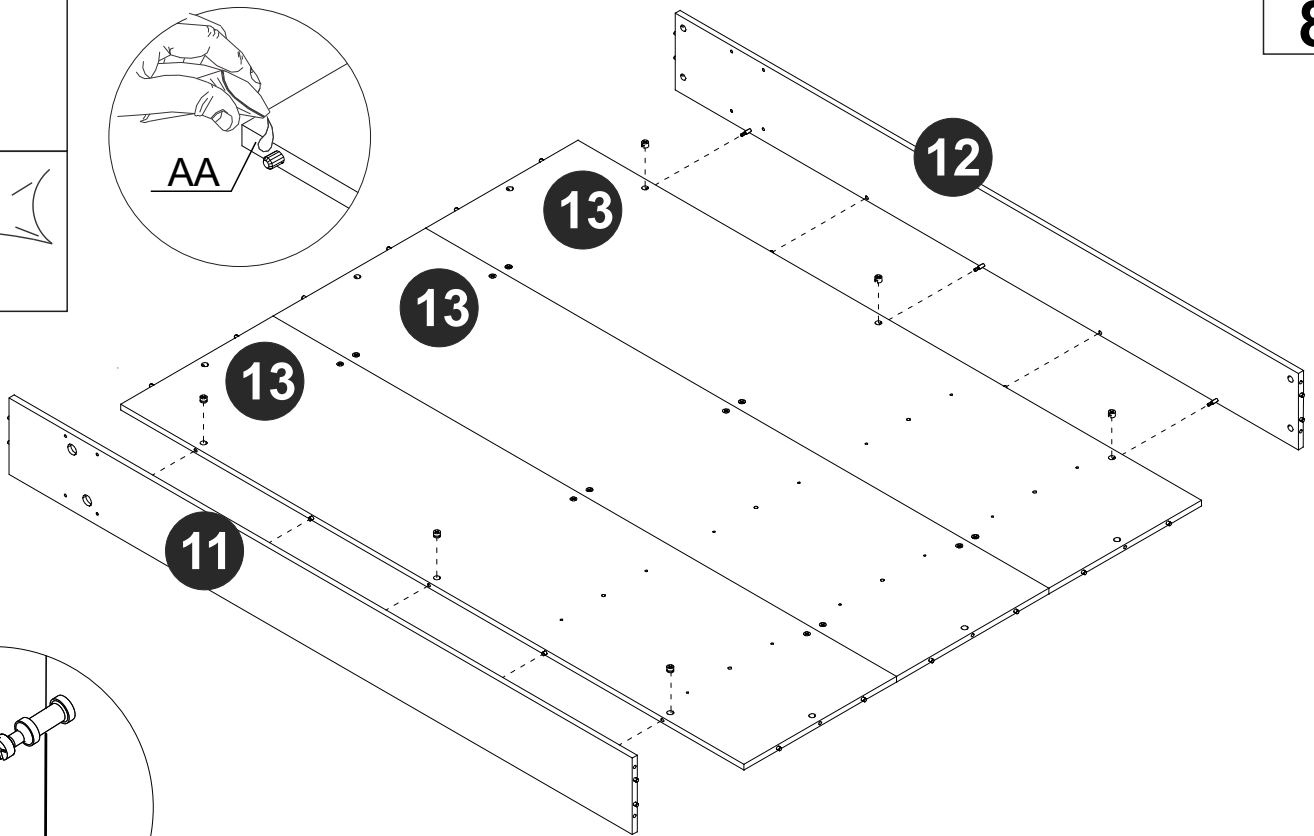
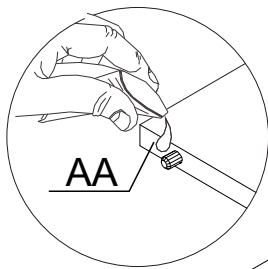
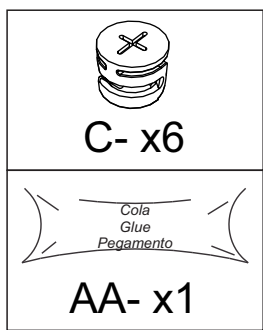

**Place cam locks. Make sure arrow is facing outwards.  
Once parts are attached, turn cam lock to the right using screwdriver.**

Coloque los tambores de minifix. Asegurese que las flechas indiquen hacia afuera.  
Una vez que las piezas se unan, gire el tambor hacia la derecha.

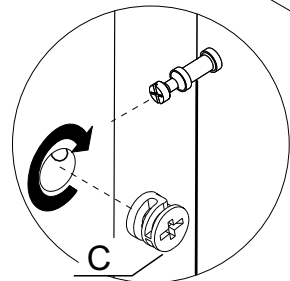
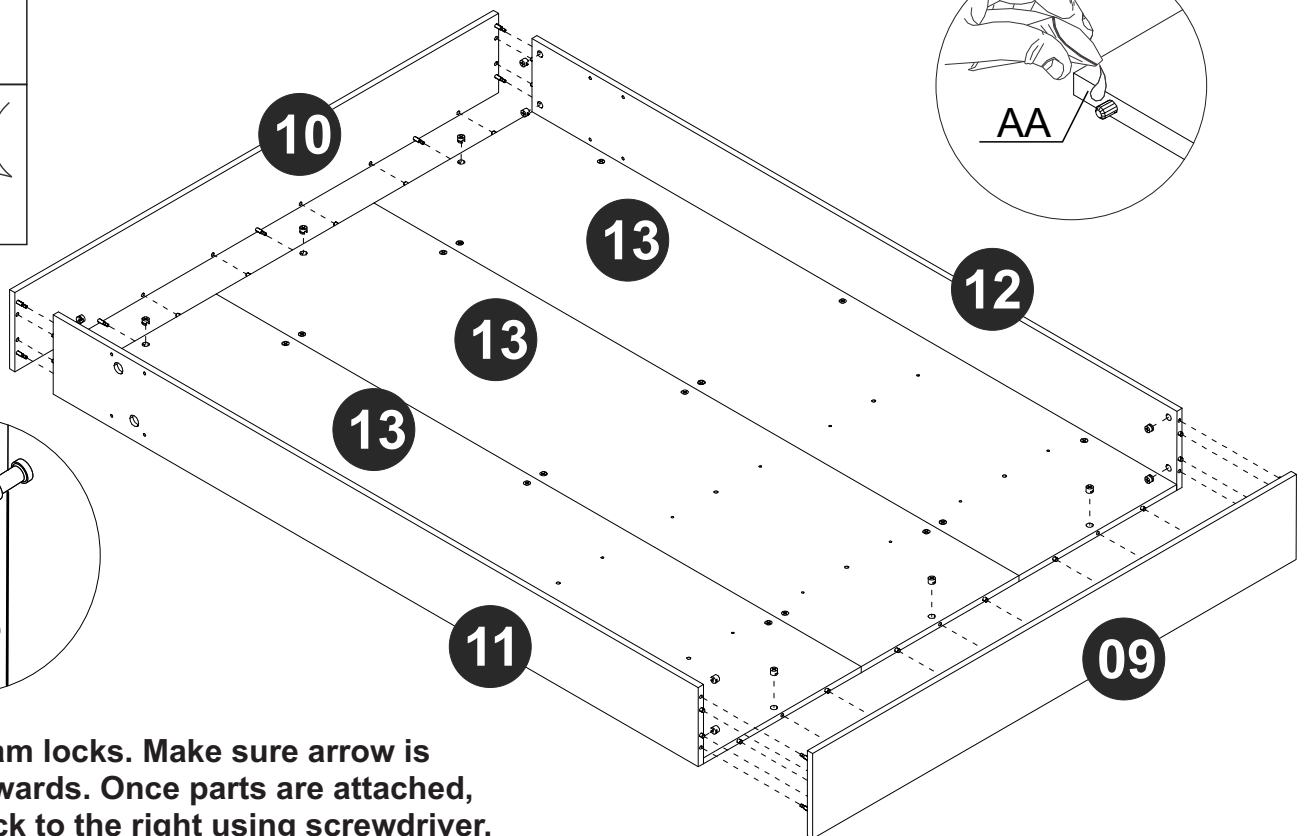
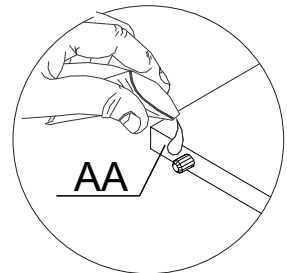
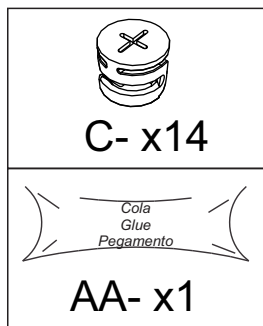

**Place cam locks. Make sure arrow is facing outwards. Once parts are attached, turn cam lock to the right using screwdriver.**

Coloque los tambores de minifix. Asegurese que las flechas indiquen hacia afuera. Una vez que las piezas se unan, gire el tambor hacia la derecha.

10

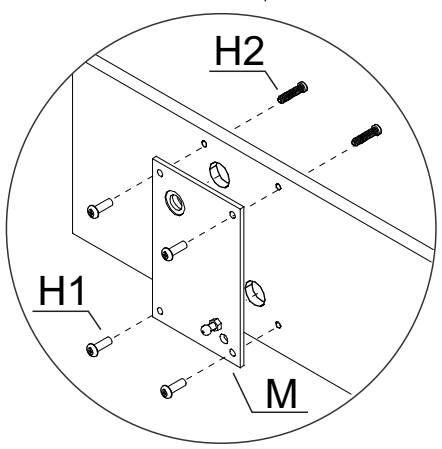
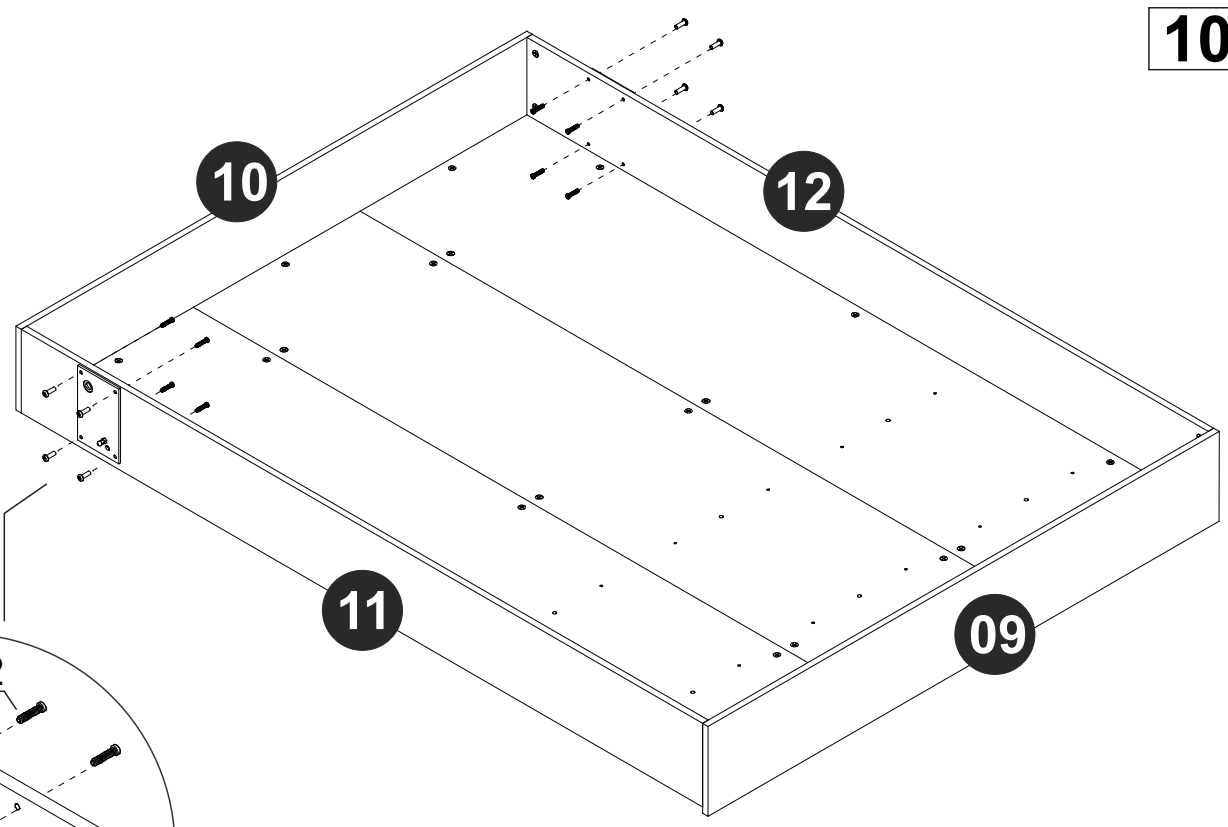
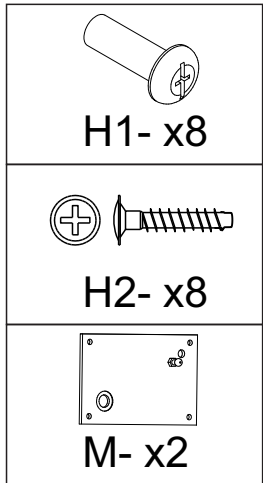

**Make sure to attach M part facing the correct way.**

Asegurese de colocar la parte M orientada al lado correcto.

11

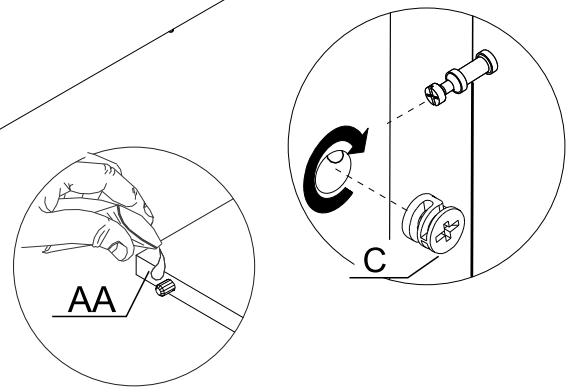
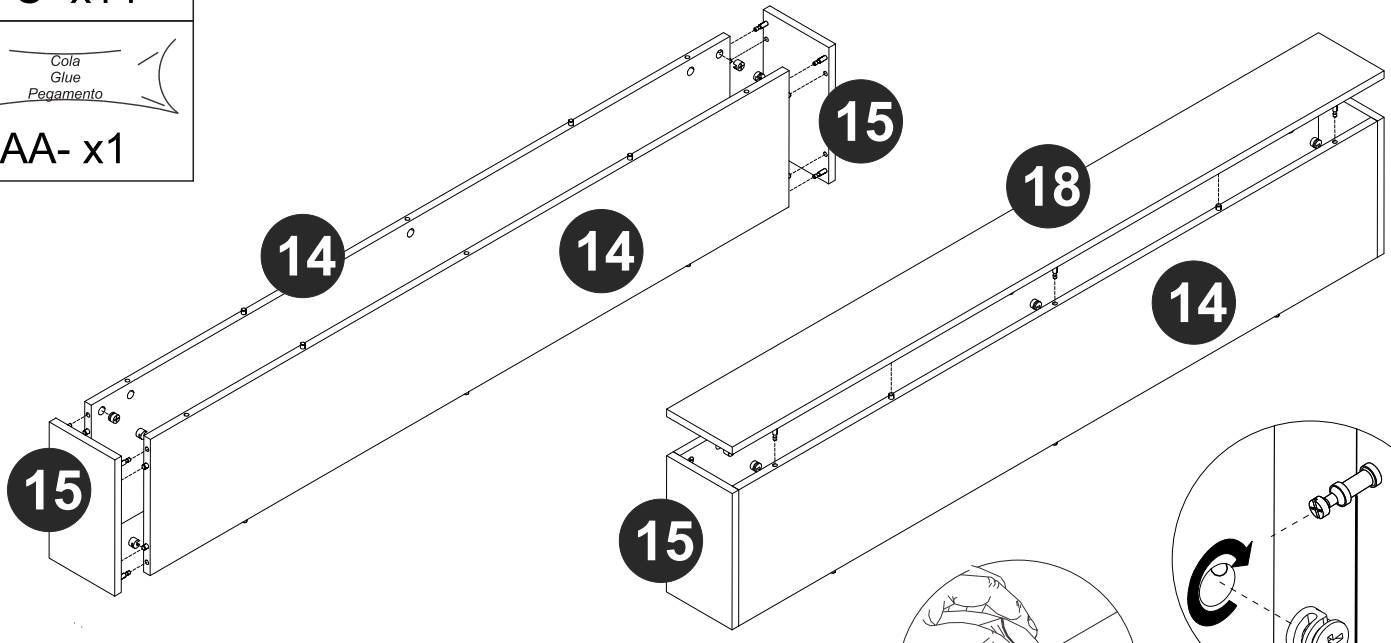
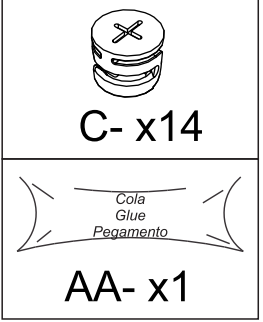

**Join parts #14, #15 and #18 to assemble the shelf.**

Una las partes #14, #15 y #18 para montar el estante.

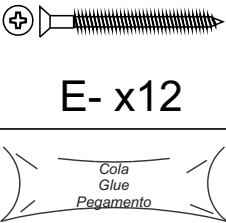

E- x12

Cola  
Glue  
Pegamento

AA- x1

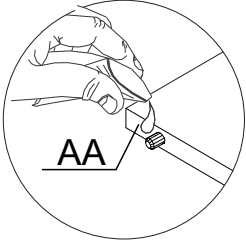
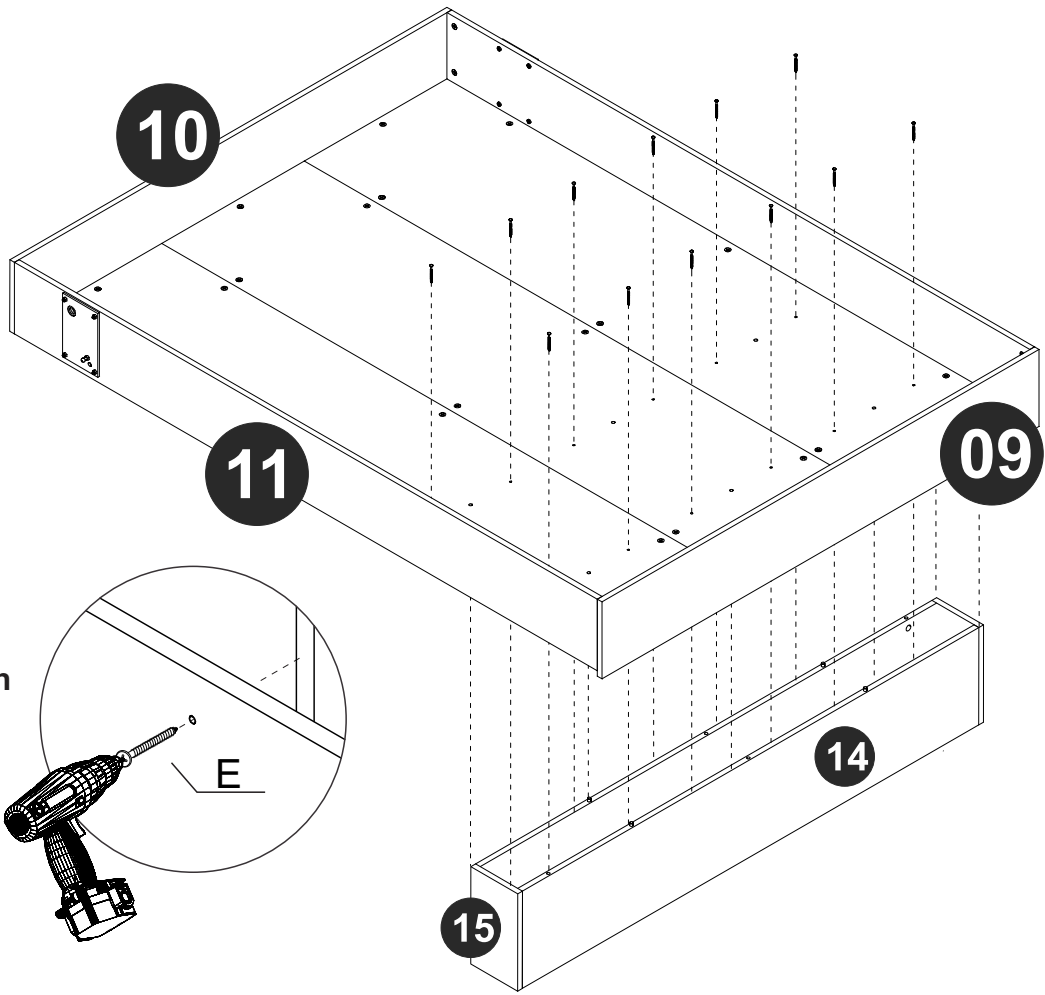

Screw shelf into bed with E screws and glue to fix.

Atornille el estante a la base de la cama con los tornillos E y fijando con pegamento.

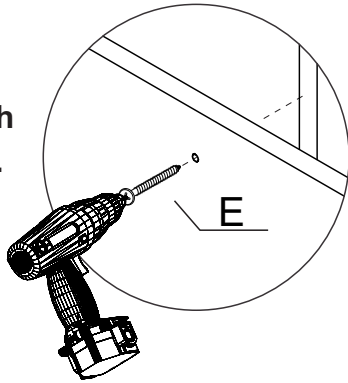
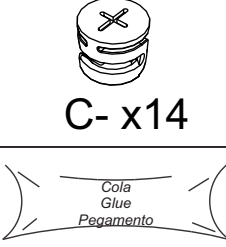
C- x14

Cola  
Glue  
Pegamento

AA- x1

Pay attention to the each part front and back.

Preste atención al frente y dorso de cada parte.

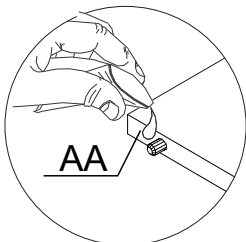
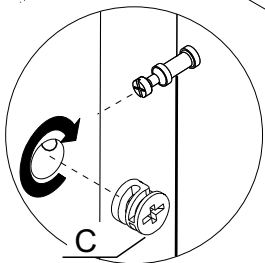
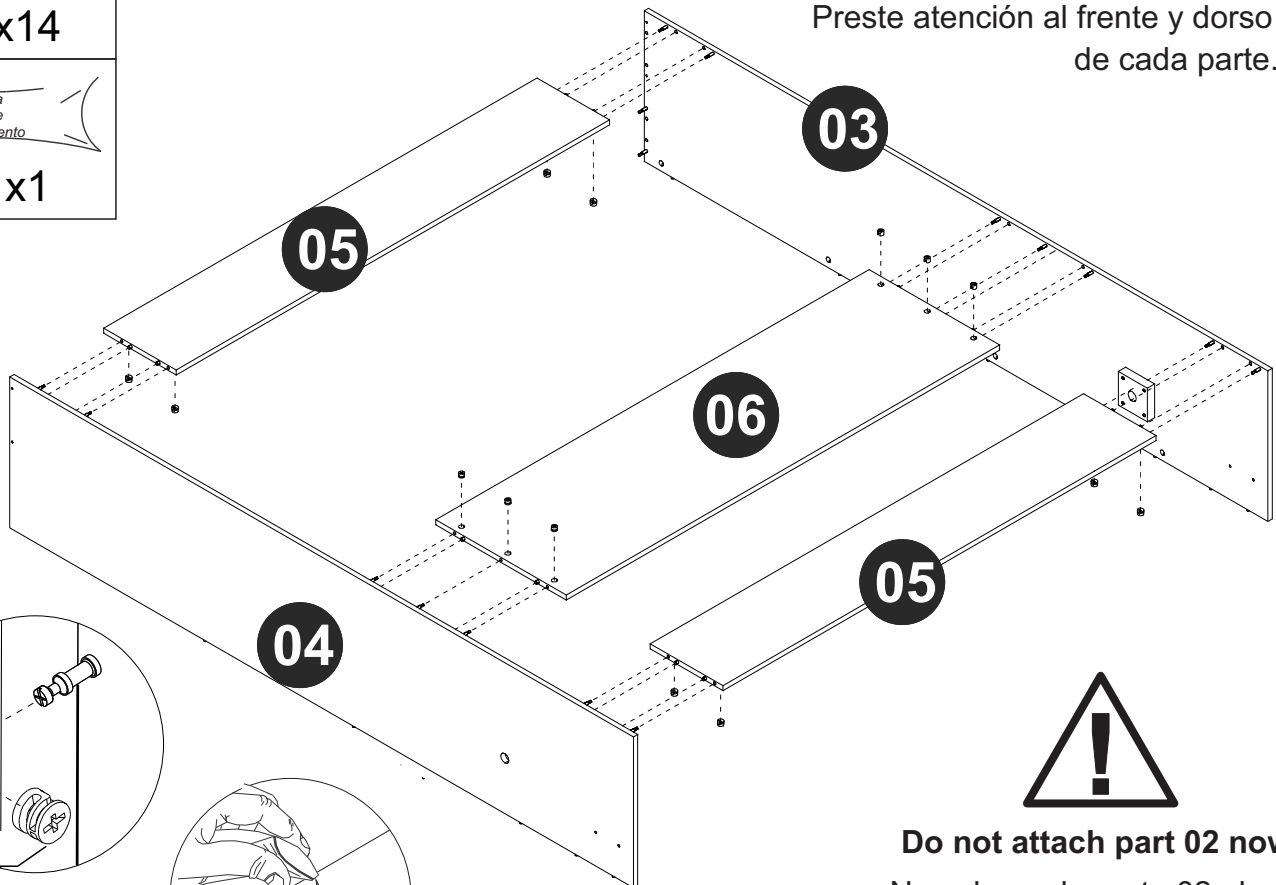

Do not attach part 02 now.  
No coloque la parte 02 ahora.

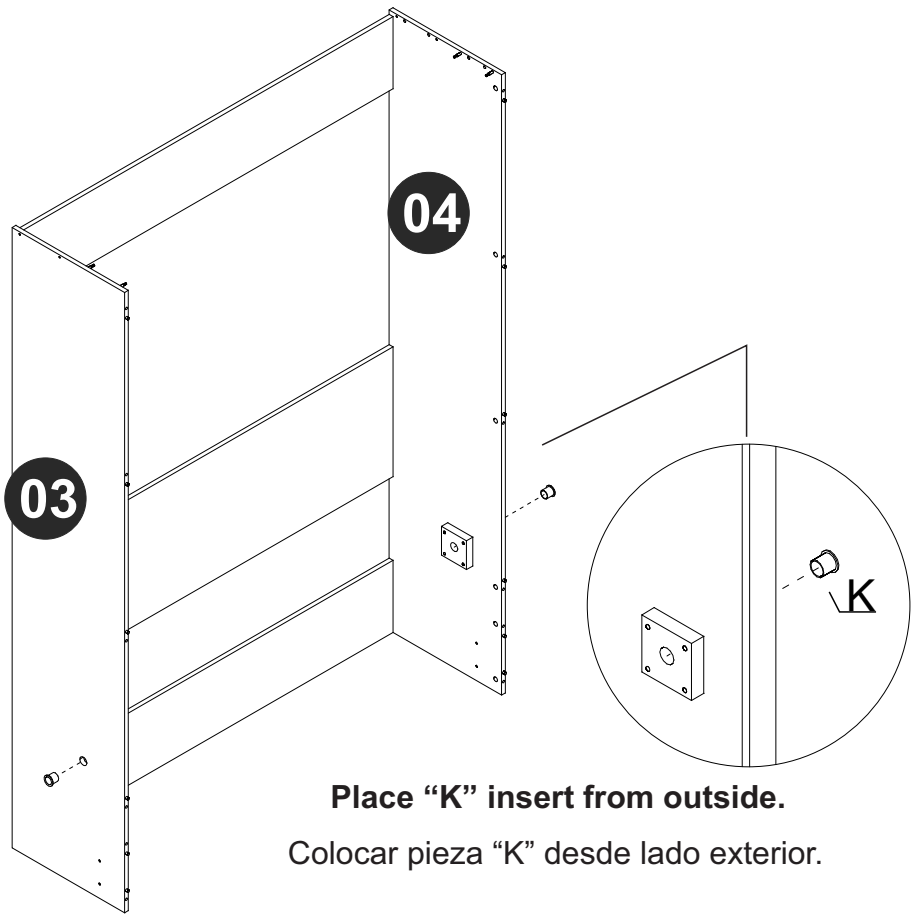
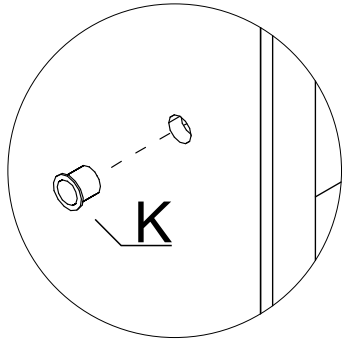
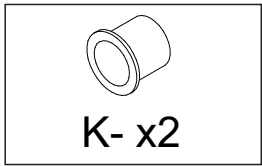

Place "K" insert from outside.  
Colocar pieza "K" desde lado exterior.



ATTENTION  
ATENCIÓN

Very important to fix the bed to the wall in this step. Following next steps without first securing the bed can lead to risk of injury.

Muy importante fijar la cama a la pared en este paso. Continuar con los proximos pasos sin asegurar la cama puede ocasionar riesgo de lesion.

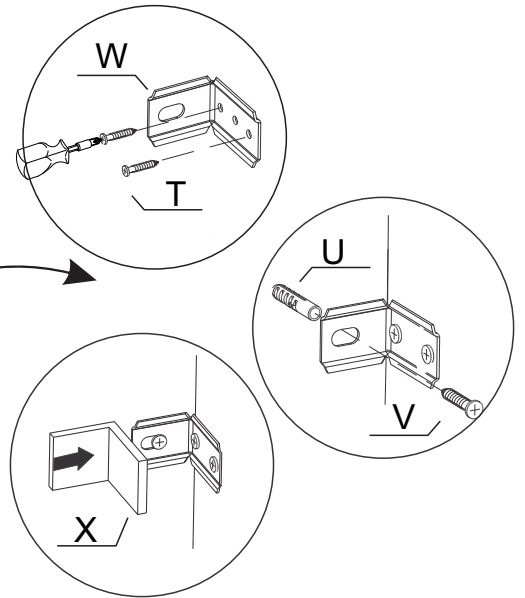
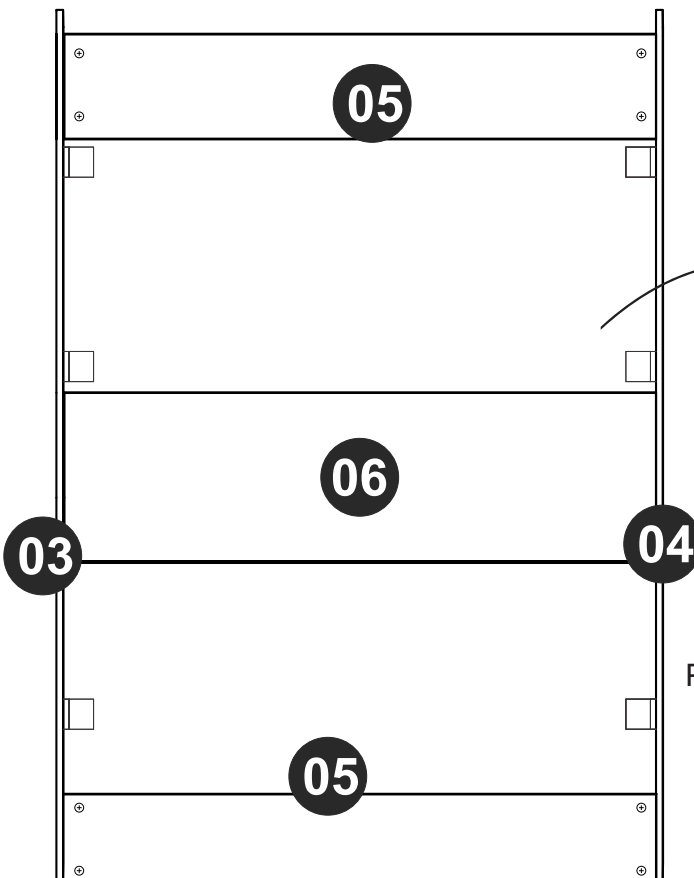
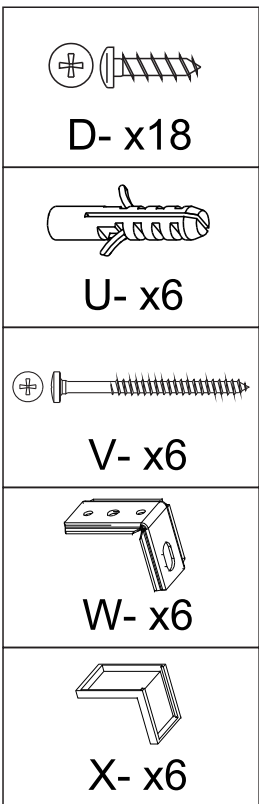

Drill the wall with an 6mm drill bit.  
Perfore la pared utilizando una broca 6mm.

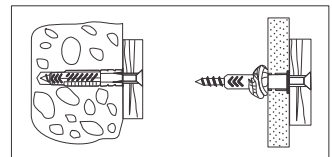



ATTENTION  
ATENCIÓN



**From here forward steps must be followed in order for a successful installation.**

De aquí en adelante deben seguirse los pasos en orden para asegurar una correcta instalación del producto.

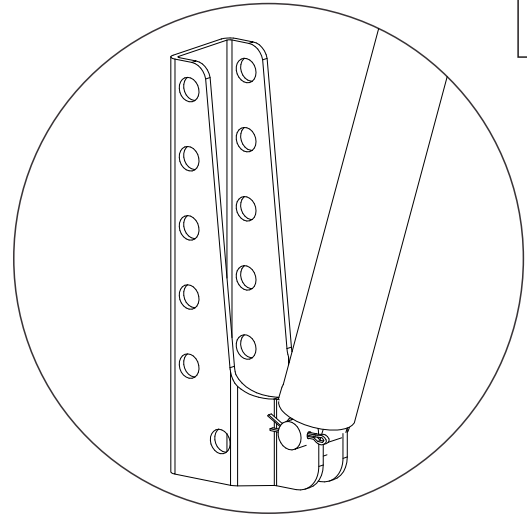
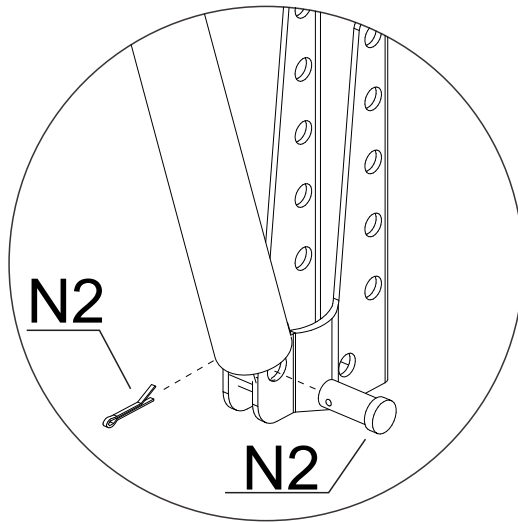
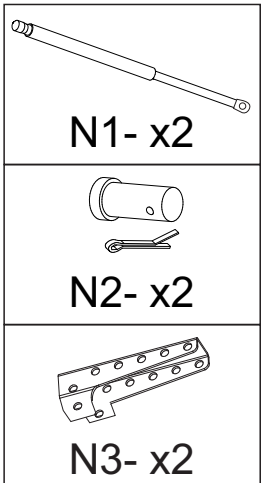

**15 A**

**Attach parts N1 and N3 by placing N2 in between.**  
Unir partes N1 y N3 al colocar el pasante N2.



**Gas spring goes in fully extended.**  
Pistón a gas se coloca extendido.

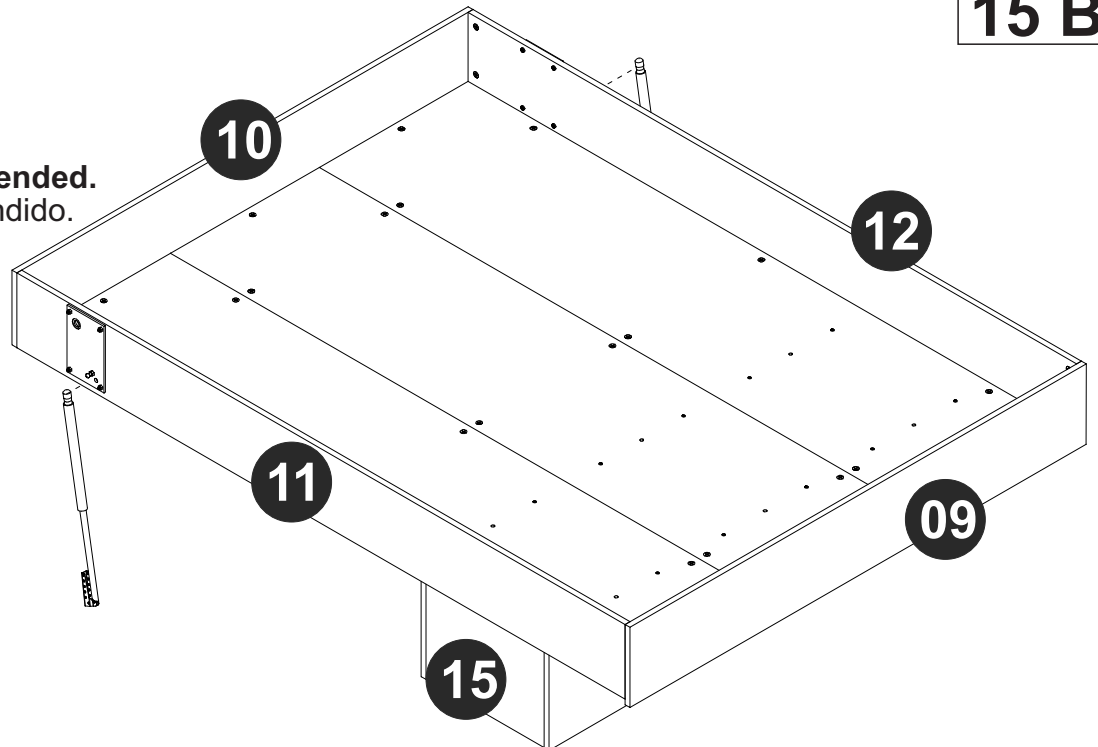
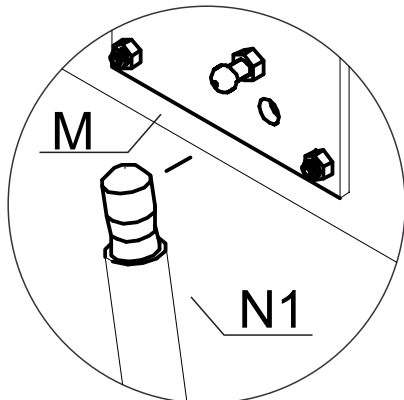

**15 B**

**Hook the ball joint gas spring N1 onto metal pin on M. Must click.**  
Enganche la rotula del resorte de gas N1 en el pin de la plaqueta M. Debe hacer click.

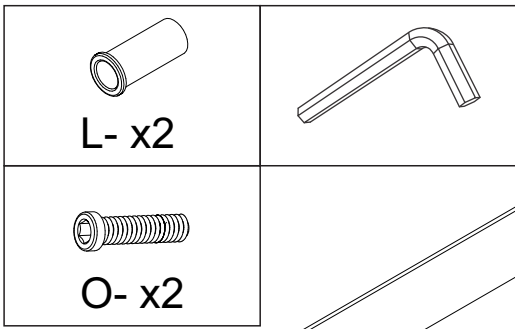

Align bed with bed frame and attach both by placing "L" insert and "O" screw on each side

Alinear la cama y el marco para poder conectarlos al colocar el inserto "L" y el tornillo "O" de cada lado.

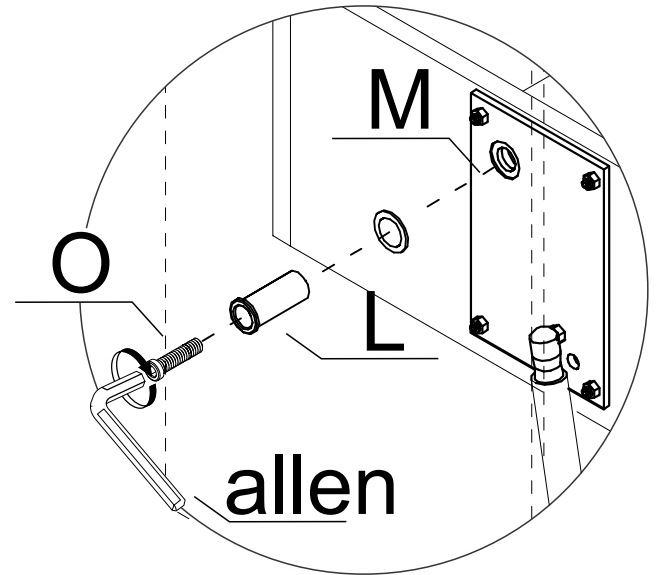
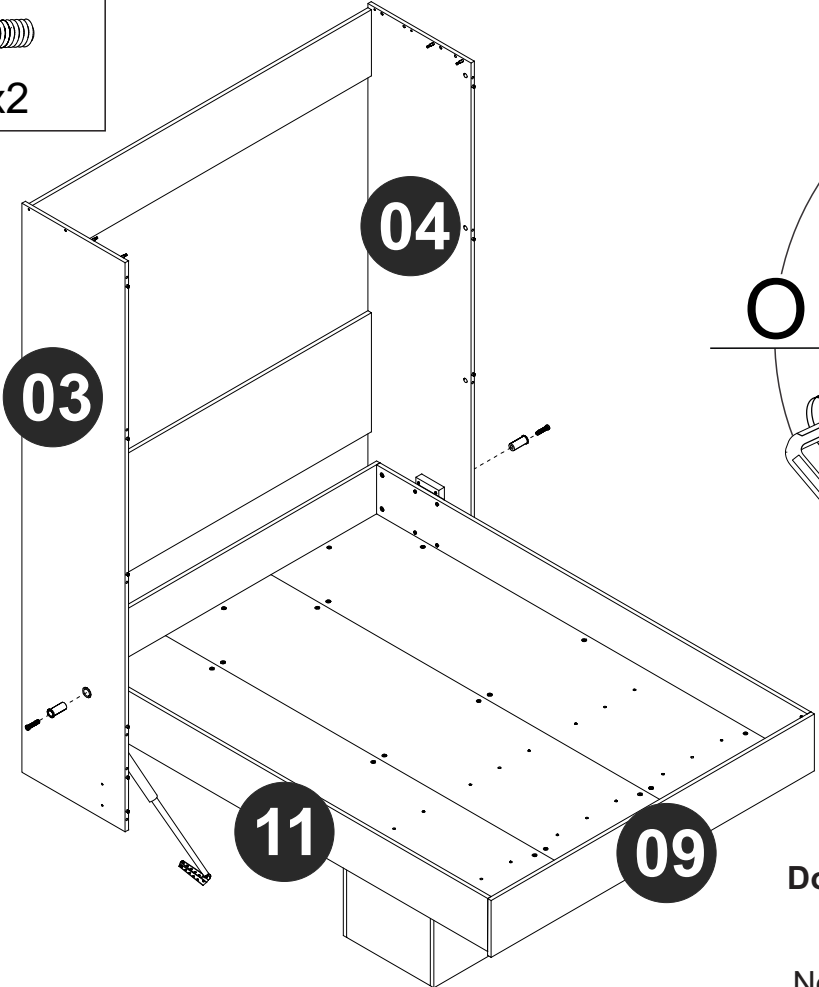

Gas spring is still fully extended. It cannot be compressed by hand. Dont screw it to frame sides at this step.

Pistón a gas está aun extendido. No puede ser comprimido a mano. No lo atornille a los laterales en este paso.

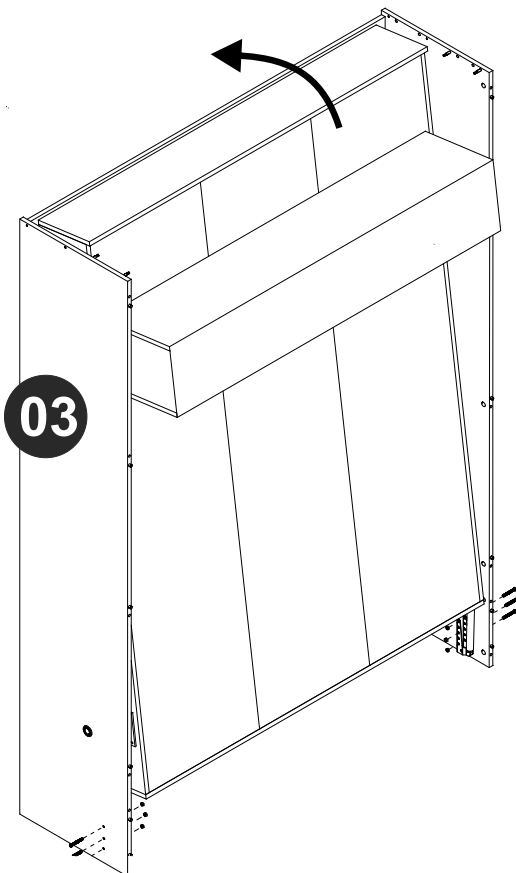
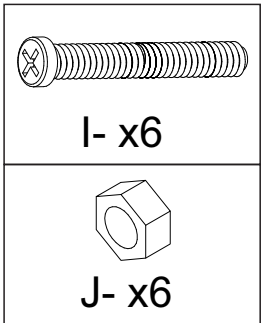

Fully push bed back to secure piston.

Empuje completamente la cama hacia atrás para asegurar el pistón.

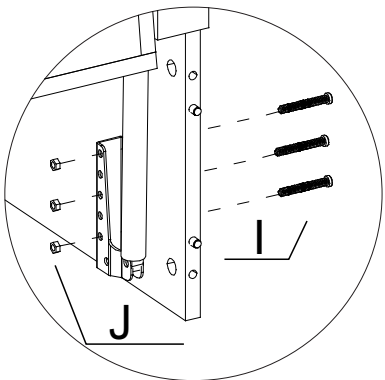

With gas spring still fully extended screw part N3 to bed frame sides.

El pistón a gas esta aún extendido. Atornille los extremos N3 a los laterales del marco de la cama.

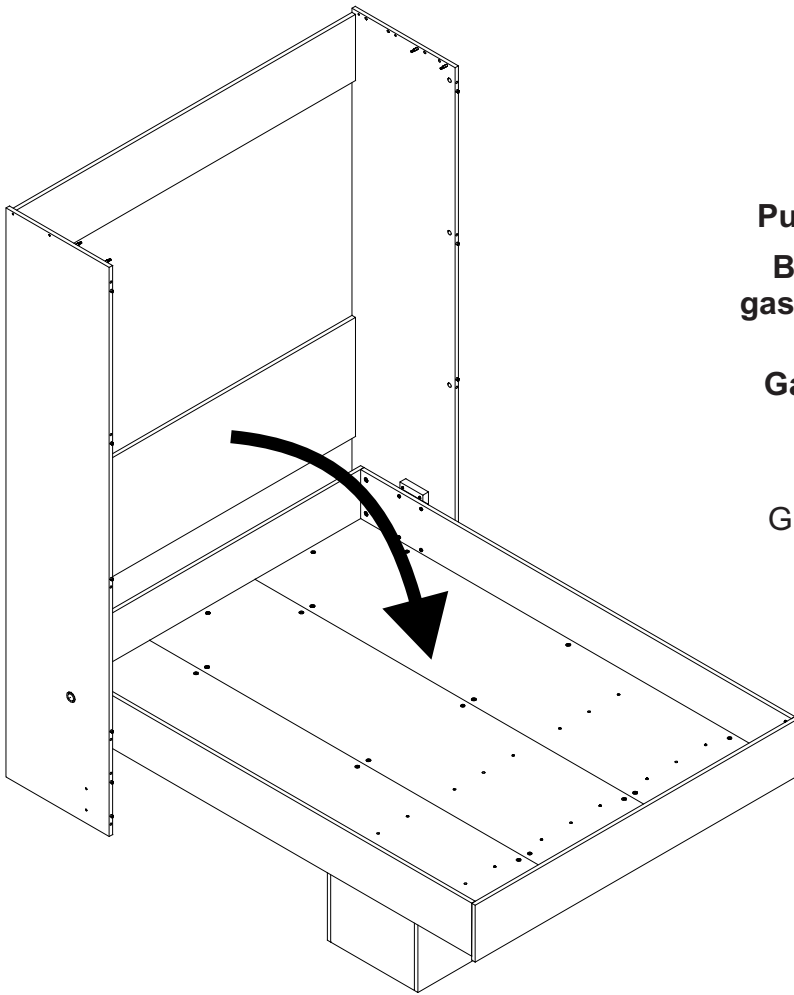

**Pull bed open slowly. Guide it safely down.**  
**Because there is no mattress inside, and gas pistons are weight rated to hold 1000 lbs it will take extra strength to pull down.**  
**Gas piston will compress for the first time when the bed is opened.**

Abra la cama despacio.  
 Guíe la misma de forma segura hasta abajo.

Como aún no está el colchón dentro, los pistones hacen la apertura mas dura y será necesario hacer fuerza extra.

El pistón se comprimirá por primera vez cuando la cama se abra.

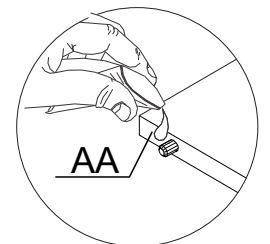
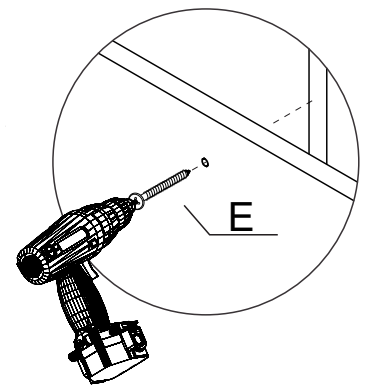
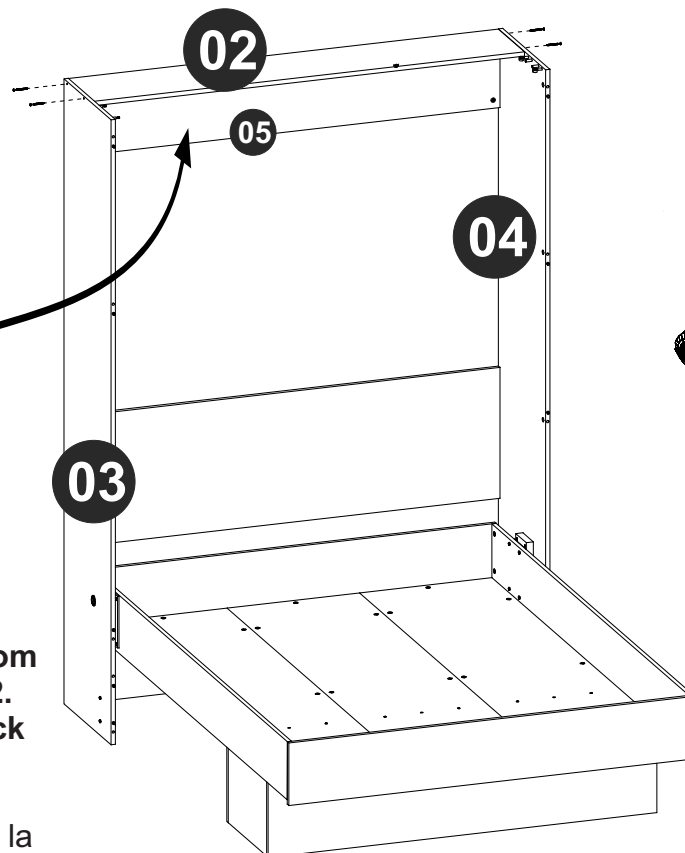
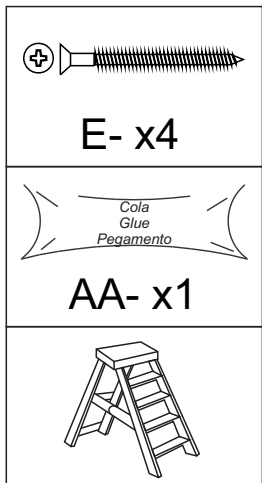

**Loosen the camlock nut (C) from part 5 in order to place part 2. Then secure again the camlock nut (C) from part 5.**

Afloje el tambor minifix (C) de la parte 5 para colocar la pieza 2. A continuación, fije de nuevo el tambor minifix (C) de la pieza 5.

 E- x6

 Cola  
Glue  
Pegamento

AA- x1



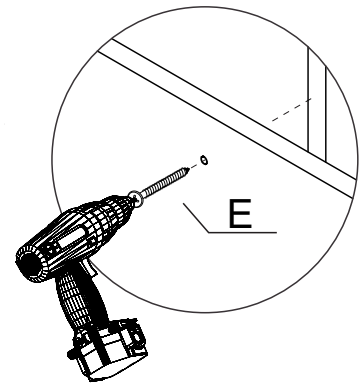
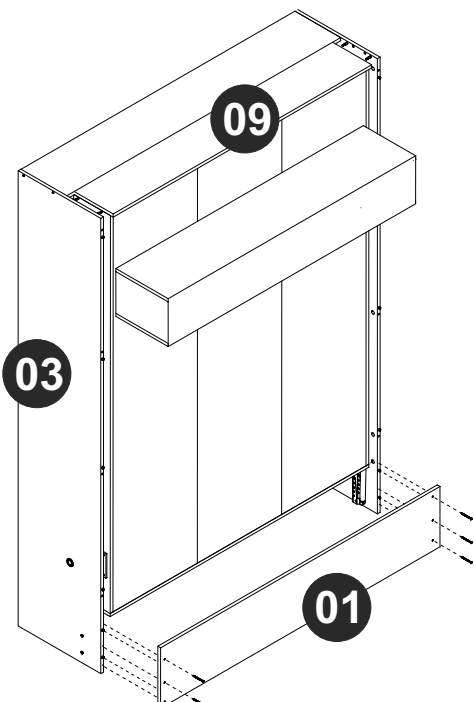
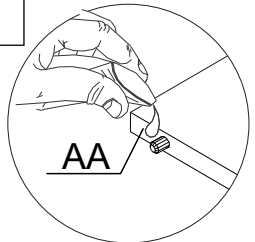

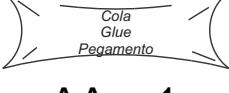

 C- x10

 Cola  
Glue  
Pegamento

AA- x1

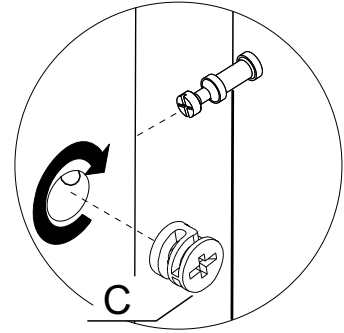
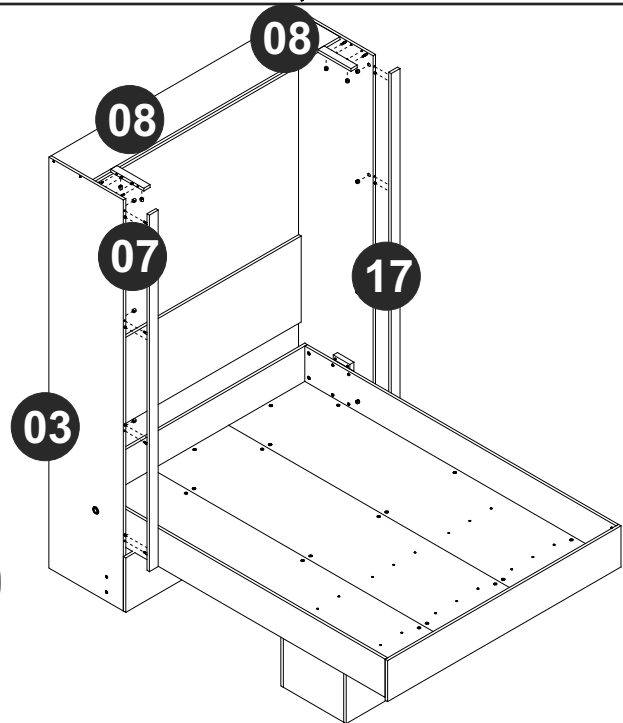
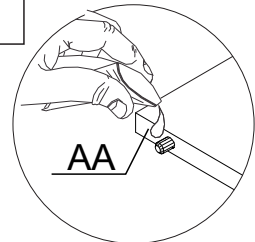



 C- x2

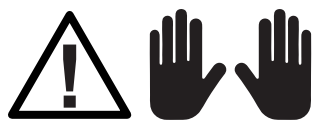

**Hold the bed ajar to adjust the camlock nut (C).**  
Sostenga la cama entreabierta para ajustar el minifix (C).

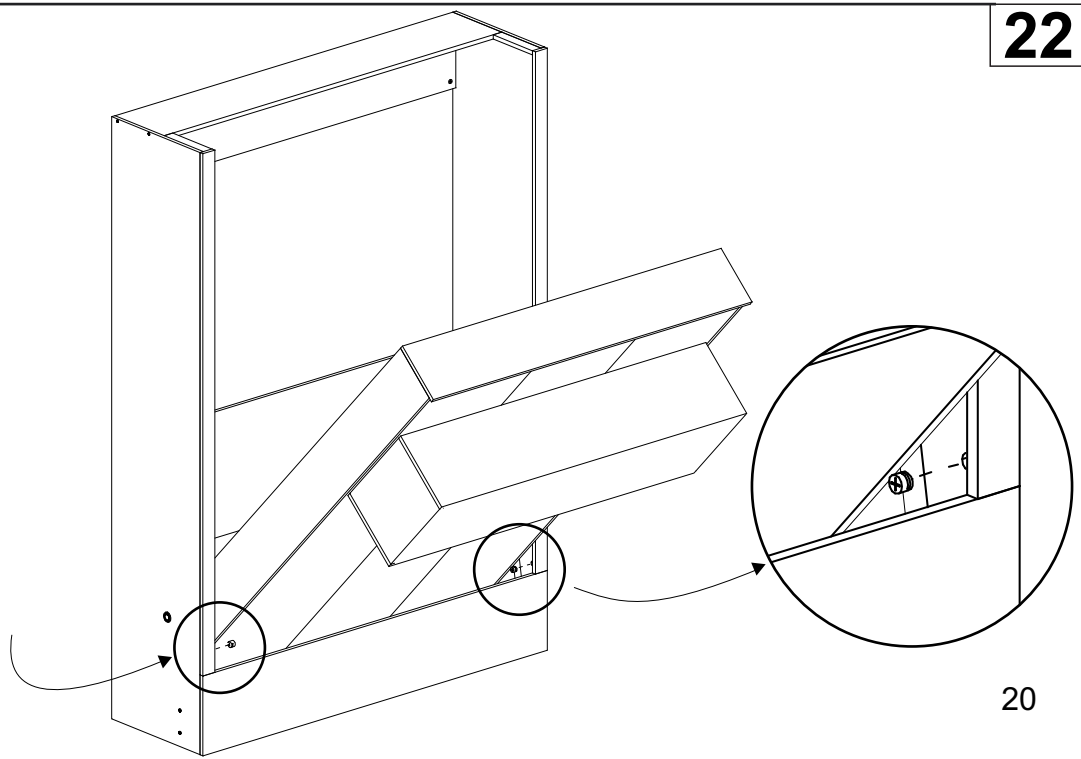

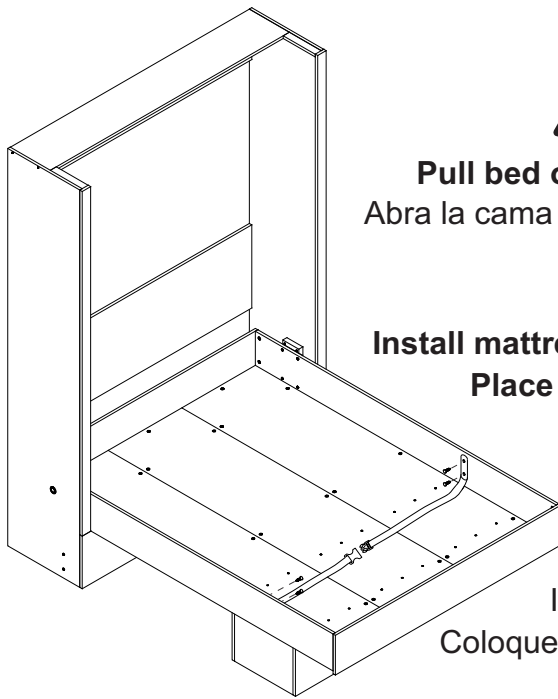
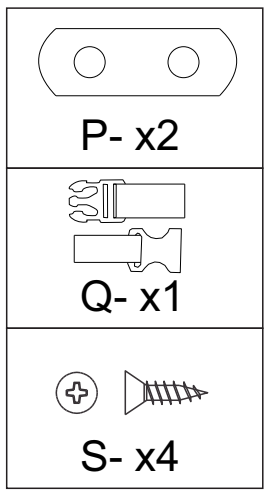

**Pull bed open slowly. Guide it safely down.**  
 Abra la cama despacio, de forma segura hasta abajo.

**Install mattress securing straps.**  
**Place mattress inside and secure properly.**

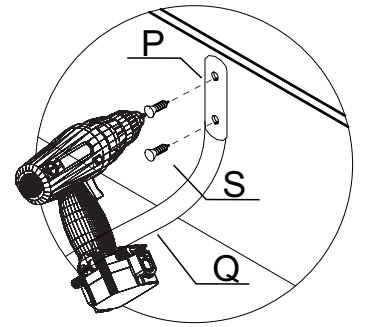

Instale la cinta de seguridad para el colchón.  
 Coloque el colchón dentro y asegure correctamente.

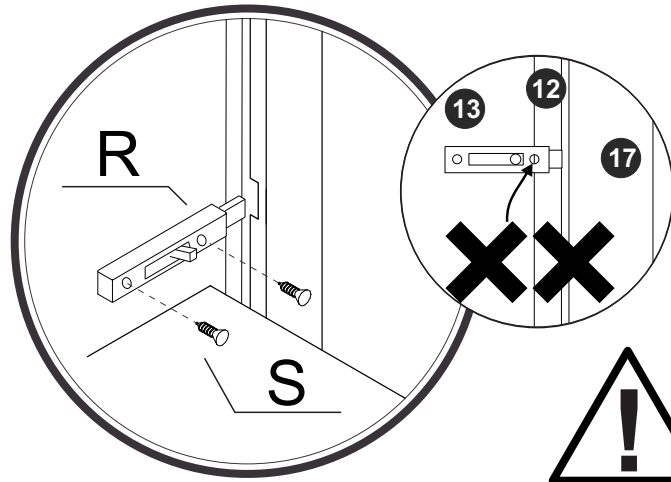
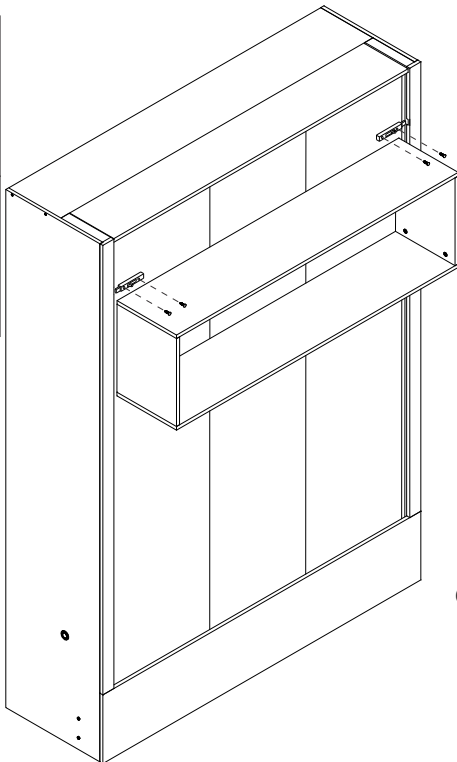
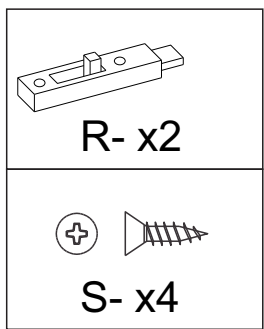

**Install safety bolts when bed is closed.**  
**Be careful not to position the screws over the edge/ in between pieces as not to break the clasp.**

Instale el pasador con la cama cerrada.  
 Tenga cuidado de no colocar el tornillo entre las piezas para no romper el pasador.

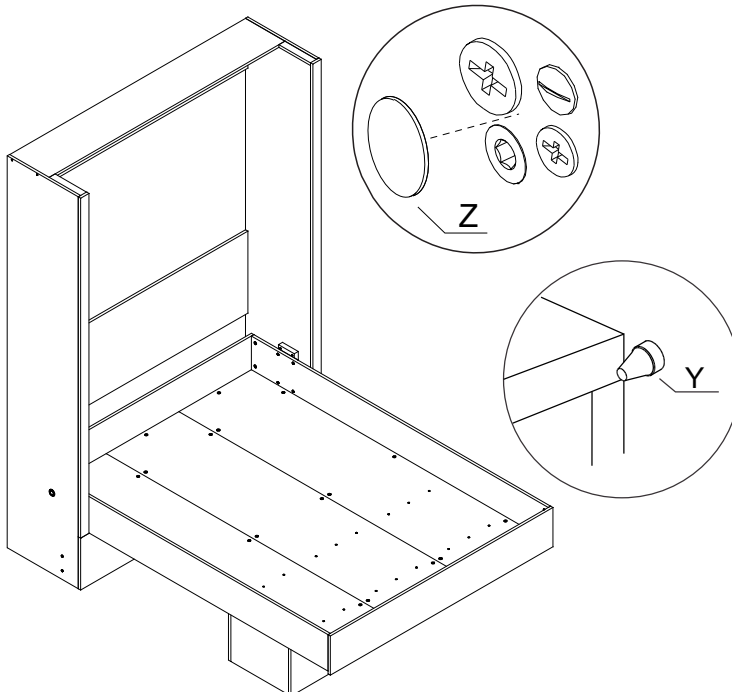
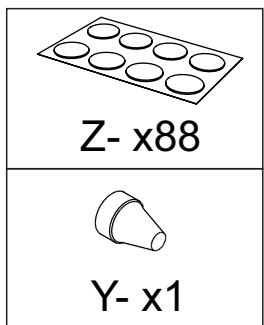

## Troubleshooting Solución de problemas

**If you experience trouble with your product assembly, try the following solutions:**

Si encuentra dificultades con el montaje de su producto, pruebe una de las siguientes soluciones:

### **Parts or hardware are missing.**

**Before starting the assembly process, please verify that all parts and hardware shown in this manual have arrived. If there is something missing, do not start assembly and contact importer for replacements. Assembling this product without all required parts and hardware may result in product damage.**

Antes de comenzar el montaje, por favor verifique que todas las partes y herrajes indicados en este manual hayan llegado. En caso de que alguna pieza falte, por favor no continúe con el montaje y contáctese con el importador para solicitar los repuestos necesarios. Montar este producto sin tener todas las piezas y herrajes puede resultar en daños al producto

### **Parts look very similar and numbered labels cannot be identified.**

**All parts have been identified with a number or code. Wooden pieces have a number label printed on one of the edges. Make sure to check all sides for this number, as due to material finishing they can be hard to find. Print can later be removed with a cloth dampened in alcohol.**

Todas las partes han sido identificadas con un número o código. Las piezas de madera llevan un número impreso en uno de los cantos. Asegúrese de revisar todos los lados por este número, ya que debido a algunos acabados puede ser difícil encontrarlos. La impresión luego puede ser removida con un paño humedecido en alcohol.

### **Gas struts came fully extended and are too tense to compress in order to be attached.**

**Gas struts are provided fully extended and should not be compressed by hand or otherwise. They need to be installed fully extended and they will compress by themselves once the bed is pulled open for the first time. Follow steps 15 to 18 for a correct installation.**

Los pistones a gas se proveen completamente extendidos y no se debe intentar comprimirlos a mano o de otra forma. Deben ser instalados extendidos y se comprimirán por sí solos al abrir la cama por primera vez. Siga los pasos desde 15 hasta el 18 para una correcta instalación.

### **Gas struts cannot reach the correct position in which to attach them.**

**For gas struts to reach the correct position in which to be fixed to the bed frame, one must follow step 17. Bed needs to be pushed all the way back, allowing parts N3 to reach the correct position for them to be screwed in. It is very crucial that part 02 has not yet been installed, otherwise it will prevent the bed from going back all that it needs to go.**

Para que los pistones a gas alcancen la correcta posición en la cual deben ser fijados al marco de la cama, siga el paso 17. Se debe empujar la cama completamente hacia atrás, permitiendo que las partes N3 lleguen a la posición donde se pueden atornillar. Es crucial no instalar aún la parte 02, de lo contrario esta pieza evitará que la cama llegue hasta dicha posición.

### **Cannot pull bed open as instructed in step 18A.**

**The bed needs to be pulled open slowly but firmly. Because there is no mattress inside and the gas pistons are weight rated to hold 1000 lbs it will take extra strength to pull down. Make sure to guide it safely down.**

Abra la cama firme y despacio. Debido a que el colchón aún no está colocado, los pistones hacen la apertura más dura y será necesario realizar fuerza extra. Guíe la cama de forma segura hasta abajo.

## Troubleshooting Solución de problemas

### **Plastic ball joint on gas strut broke when pulling bed opened for the first time.**

The plastic ball joint at the end of the gas strut can break or come apart if it is not correctly installed on to the pin. If when pulling the bed open you hear a plastic breaking sound please review the ball joints to ensure they are in good condition. If ball joint came apart just put it back together. If ball joint breaks, contact importer for a replacement part. The broken ball joint can be screwed out and a new one screwed in.

La rotula de plástico del pistón puede desarmarse o quebrarse si no es instalada correctamente en el pin. Si al abrir la cama escucha sonido de plastico, revise el estado de las rotulas. Si la misma esta desarmada, coloque las mismas nuevamente en su lugar. Si el plastico esta quebrado contacte al importador para solicitar un reemplazo. Desenrosque la pieza quebrada y enrosque el reemplazo en su lugar.

### **Bed platform does not align properly with bed frame in upright position.**

If after step 20, bed doesnt align with bed frame when closed, this means that either the wall or the floor is not squared. Check that the bed frame is fixed leveled to the wall. If it is not, you may need to adjust the bed frame to make it level. You can use a piece of cardboard to push up the side that remains lower.

Si luego del paso 20, la cama no se alinea correctamente con el marco de la cama cuando cerrada , esto significa que la pared o el piso no está en escuadra. Verifique que el marco de la cama esté a nivel. Si no lo está, será necesario acomodar el marco de la cama. Use una parte de cartón para empujar el lado del marco que queda hacia abajo para nivelarlo.