

x2

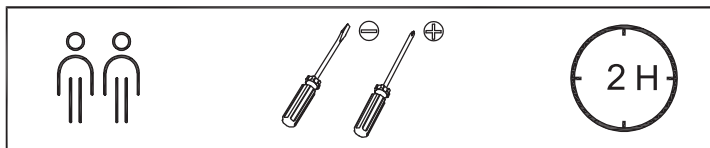

CAUTION:When tightening the screws,tighten sequentially.Do not tighten any screws fully and then towards the next one.When every part is OK, then tighten all the screws.







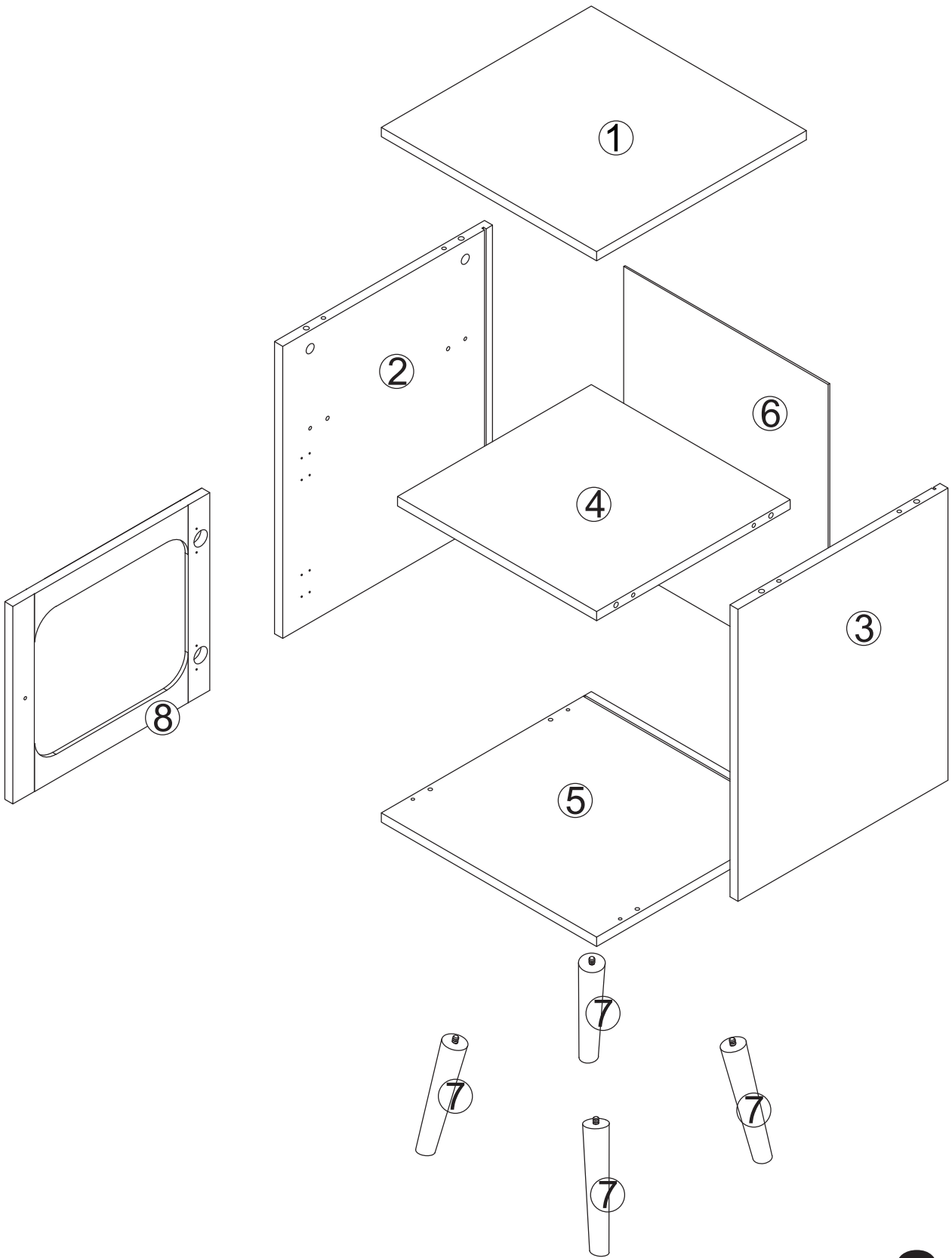



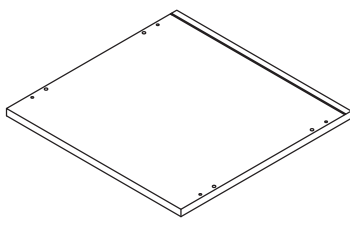
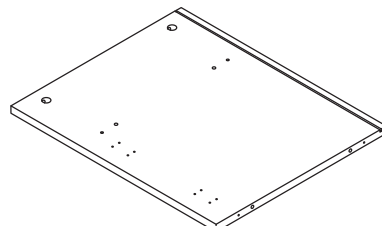
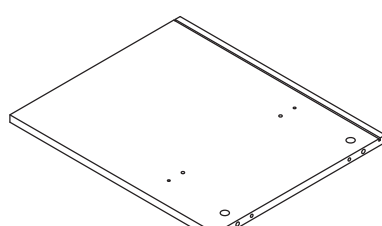
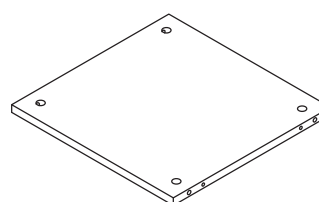
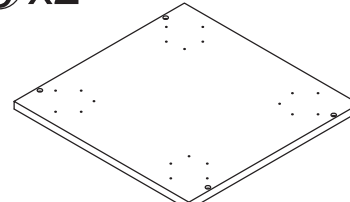
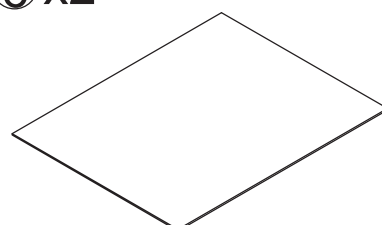
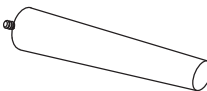
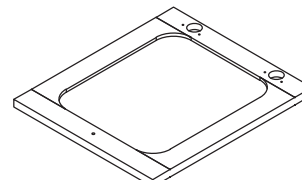

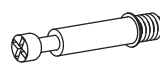

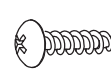
PLEASE BE CAREFUL DO NOT DAMAGE THE HOLE POSITION WHEN YOU USE POWER TOOLS !

If there are any missing parts, please contact us and we will send you the corresponding replacement part. We also offer an exclusive one-month service where we provide product replacements without the need for repairs, as long as the damage is not caused by human error.

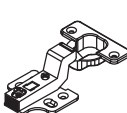

x2

① x2 	② x2 	③ x2 
④ x2 	⑤ x2 	⑥ x2 
⑦ x8 	⑧ x2 	

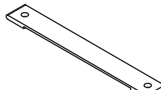
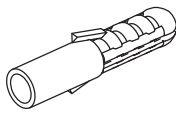
A X8(+1)  Ø6x35mm	B X8(+1)  Ø15x10mm	C X12(+1)  Ø6x30mm	D X21(+2) 
E X5(+1)  Ø4x35mm	F X4 	G X8(+1)  Ø3x16mm	H X8(+1) 
I X1 	J X1 	K X4 	L X2 
M X12(+1) 	N X1 	O X1 	x2

SPECIAL TIPS FOR FITTING CAM-LOCKS AND QUICKFIT

CAM-LOCK

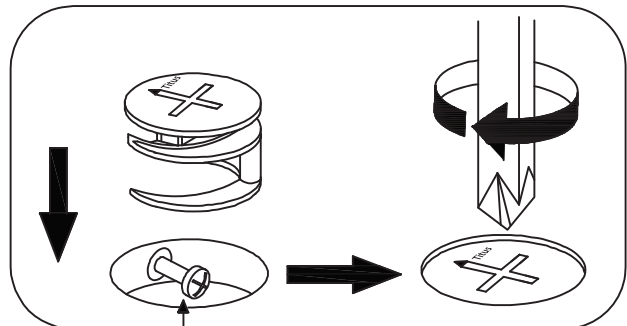
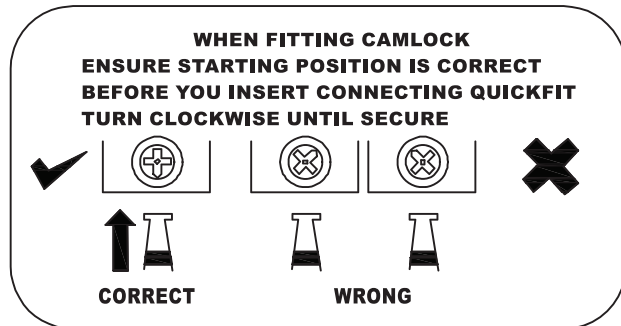

Quickfit head needs to be in centre

QUICKFIT

Tighten until shoulder is flush with panel. DO not overtighten or undertighten (see example below)

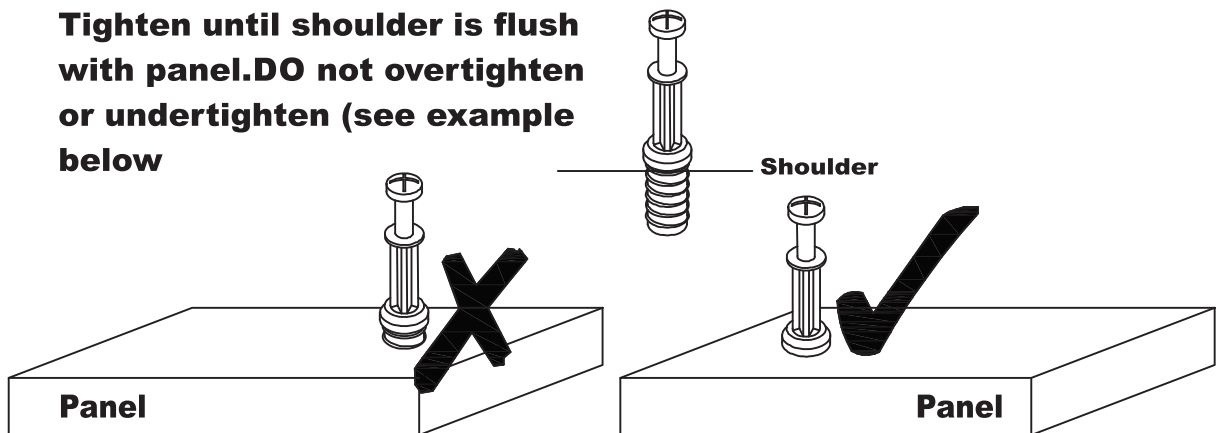

1 x2

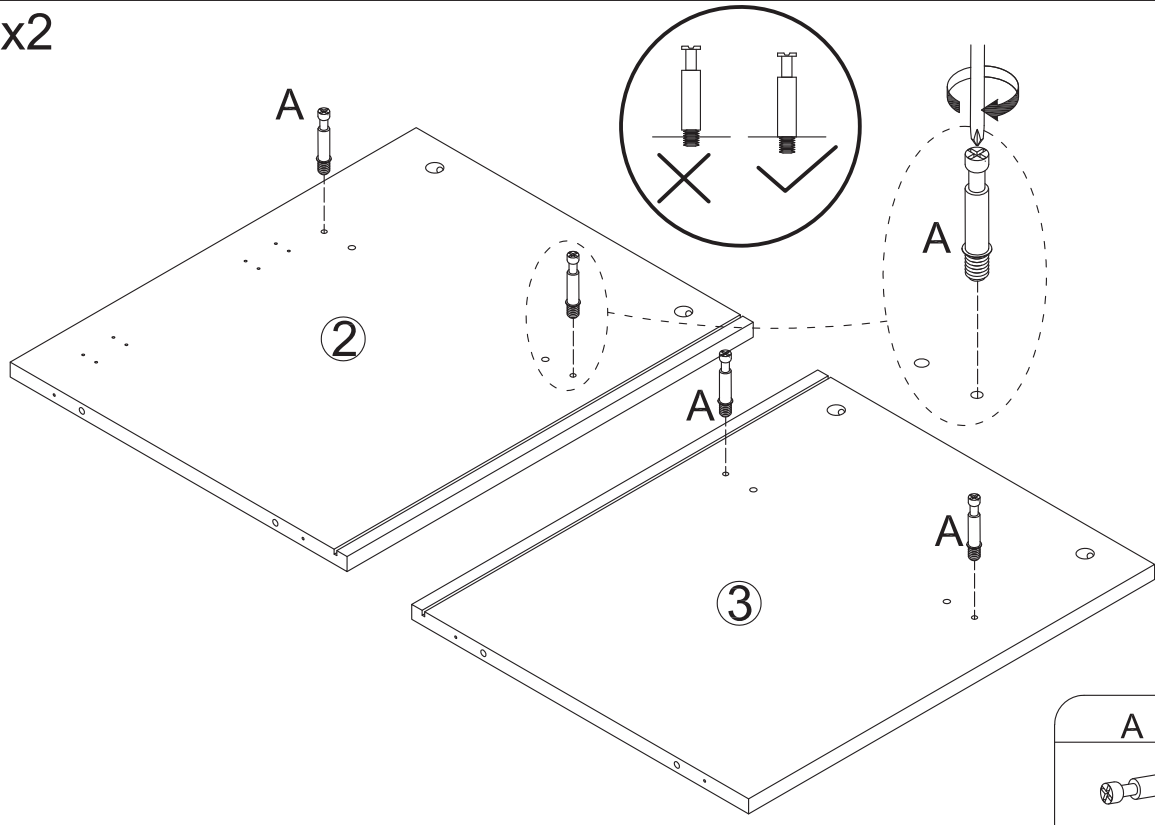

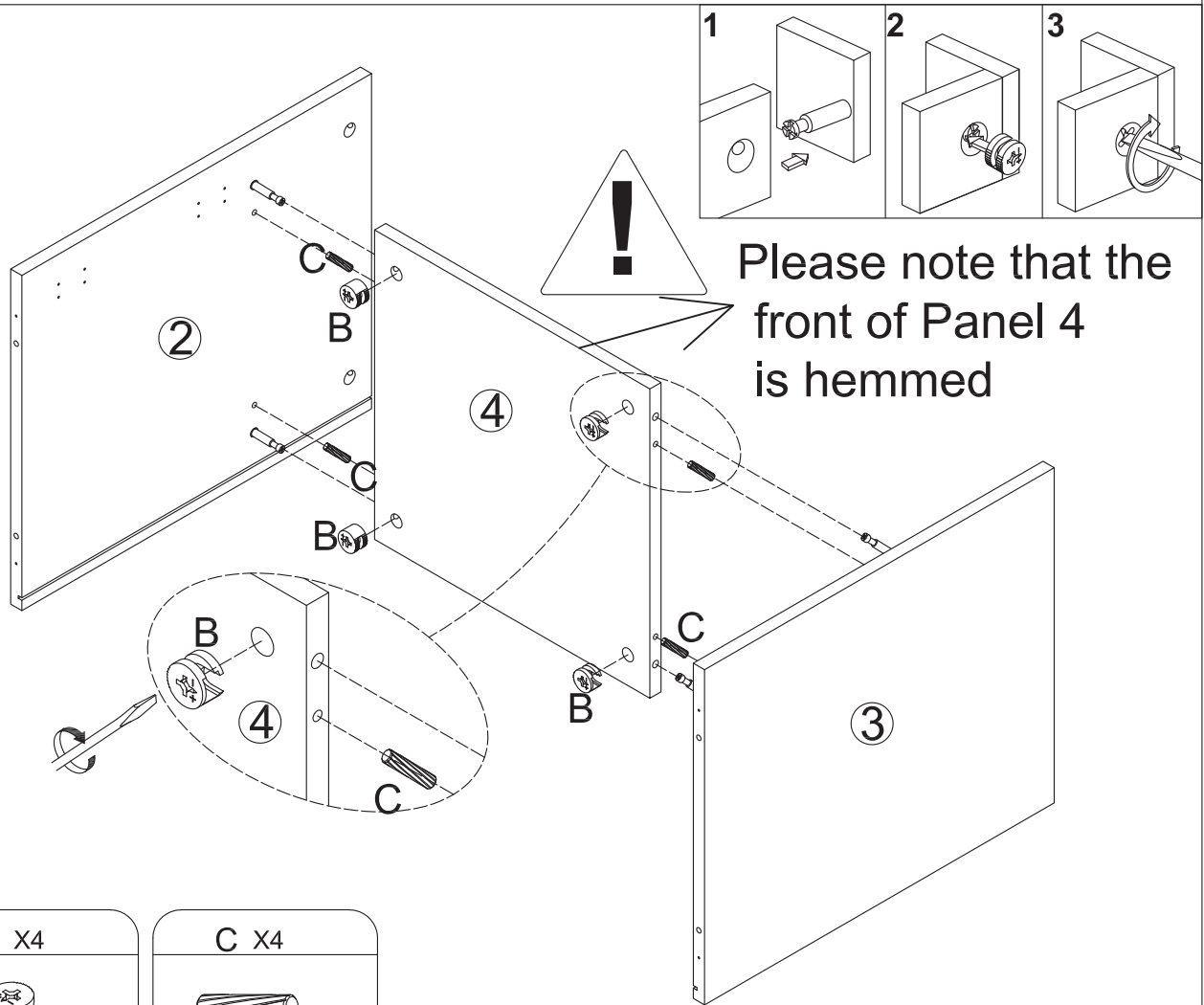

2 x2



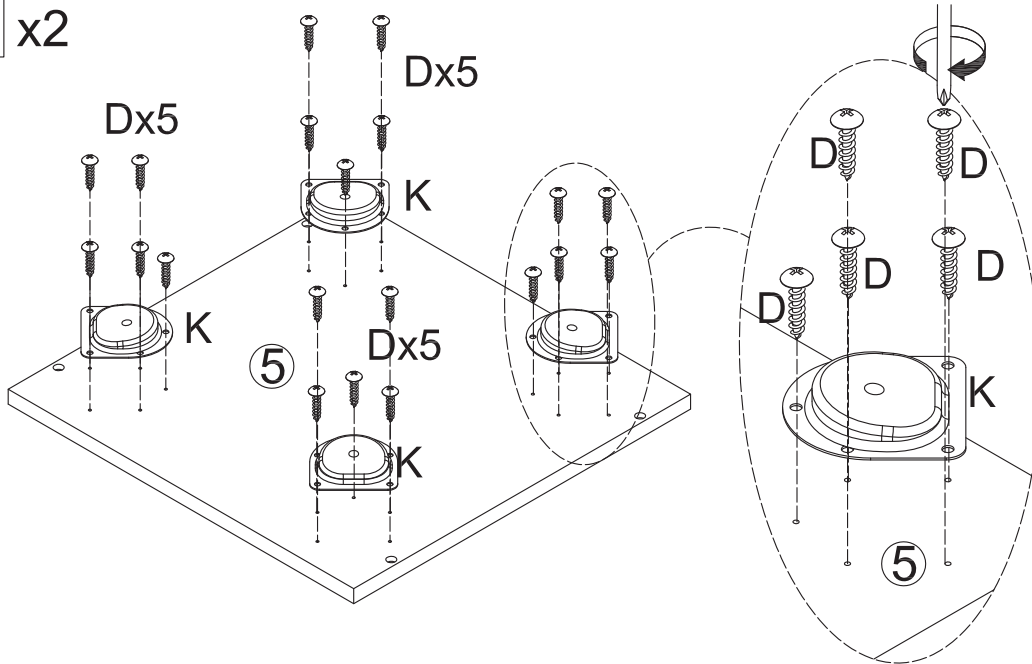

3 x2

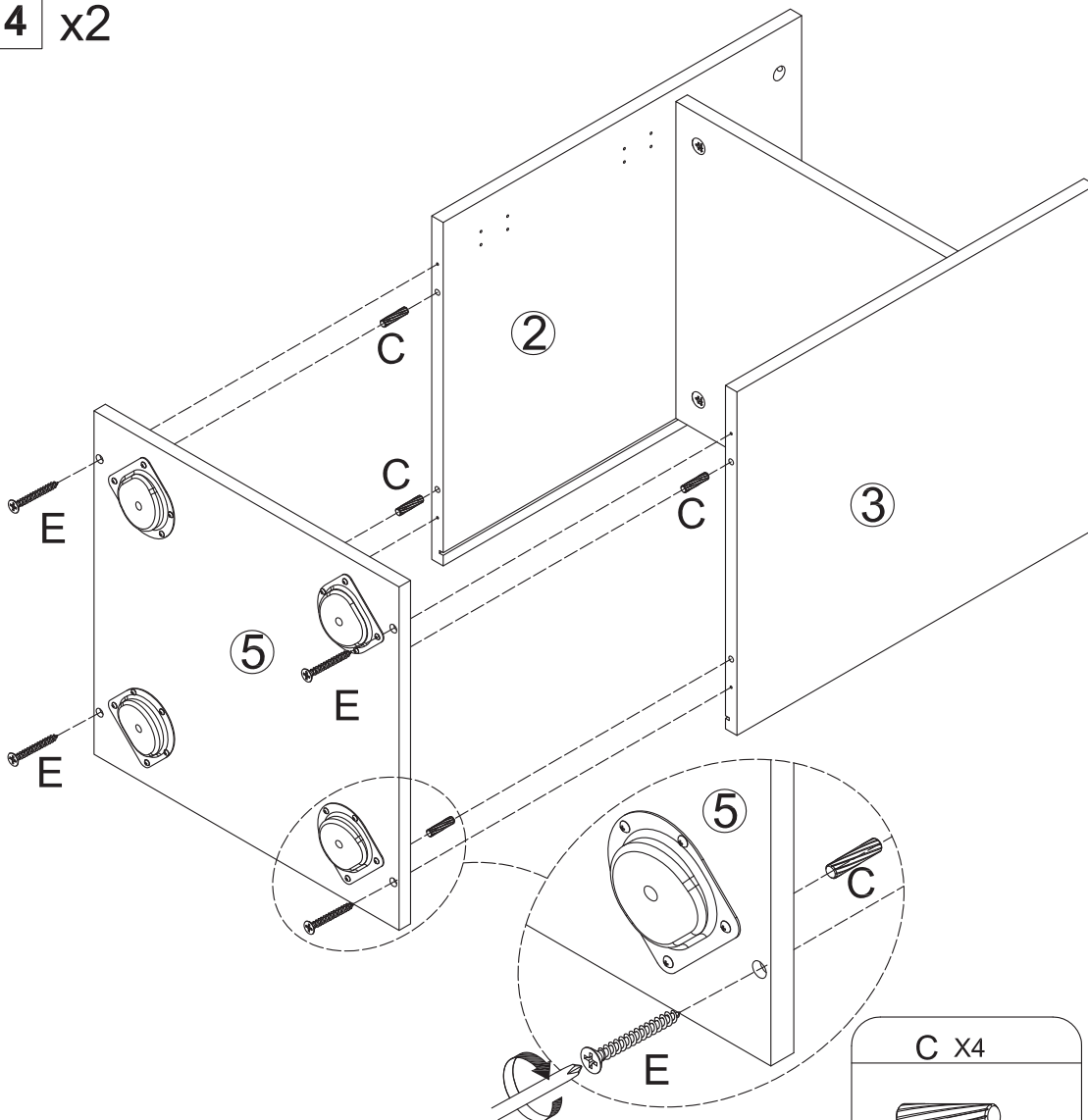

D X20

K X4

4 x2

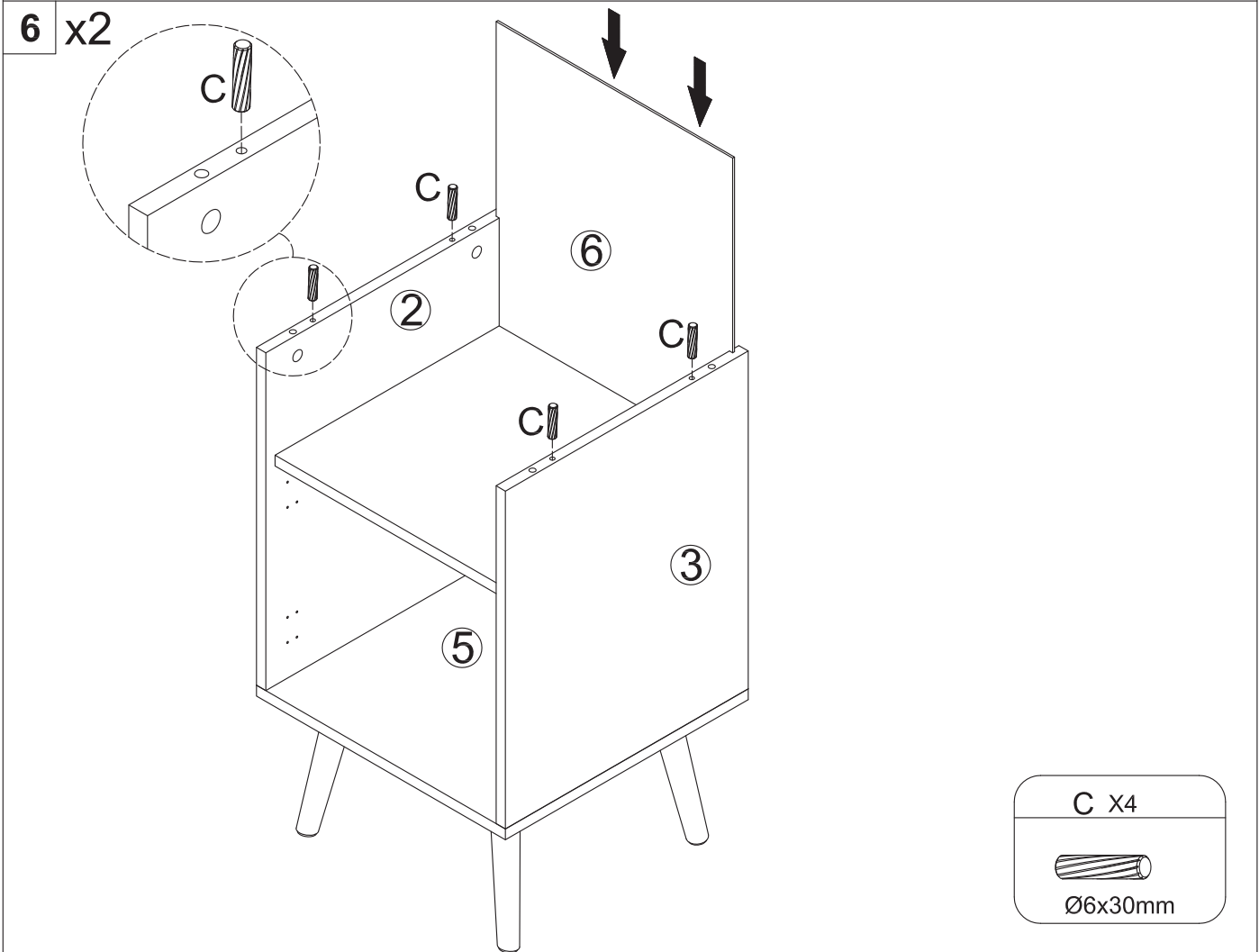
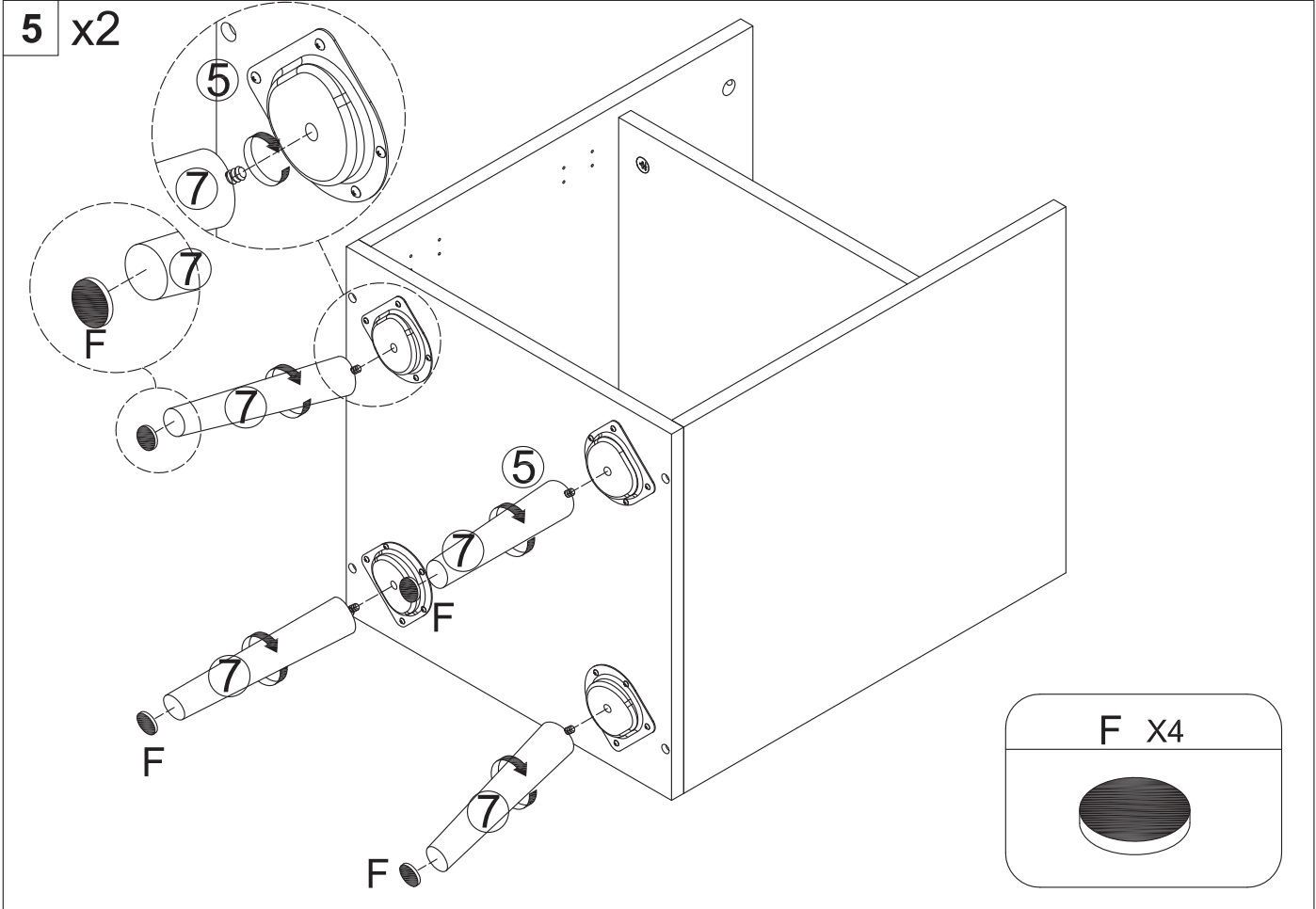

C X4

Ø6x30mm

E X4

Ø4x35mm

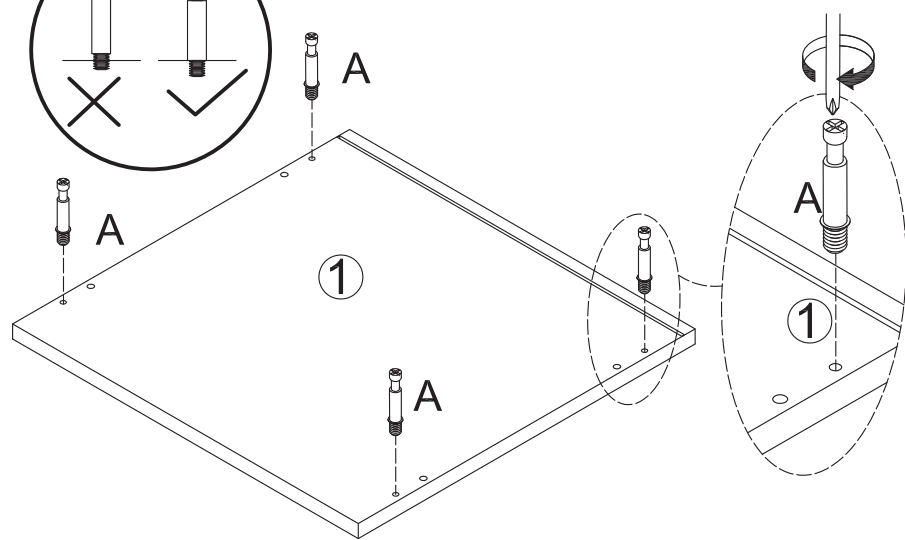
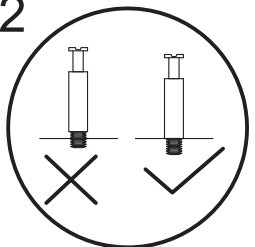

7 x2

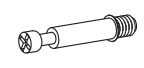

A X4



Ø6x35mm

8 x2

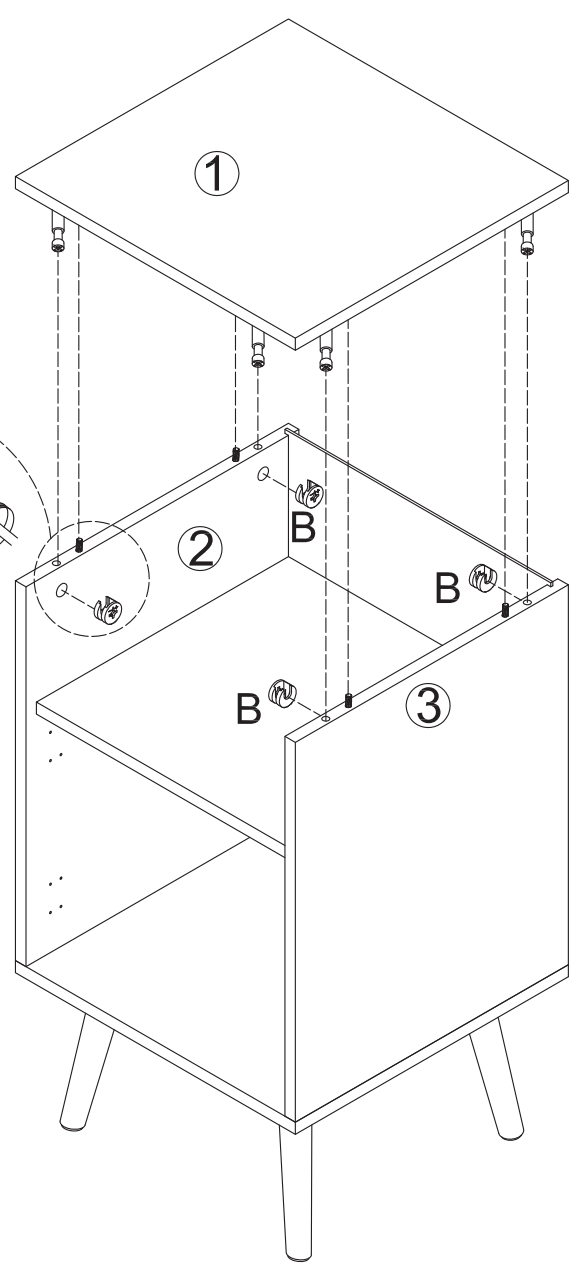
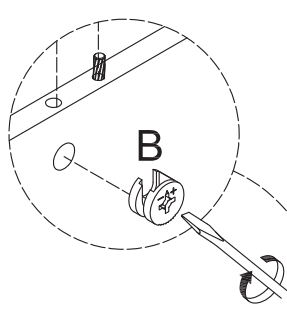
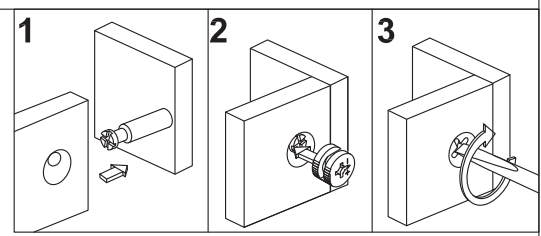

B X4



Ø15x10mm

9 x2

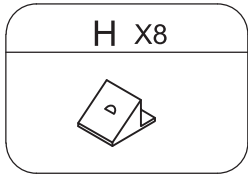
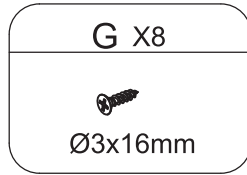
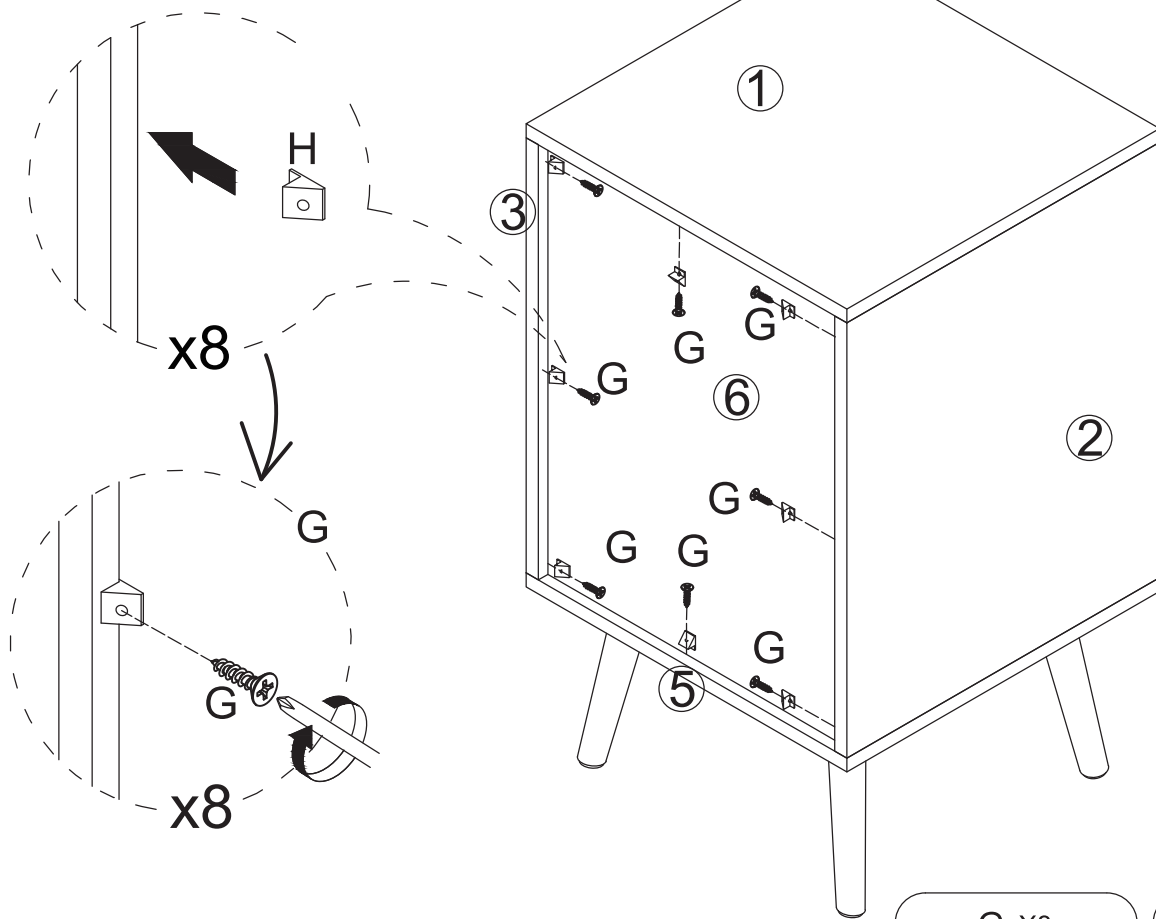

10 x2

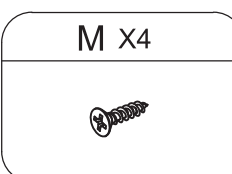
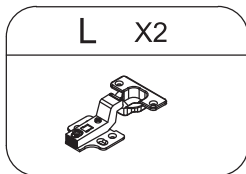
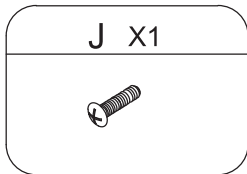
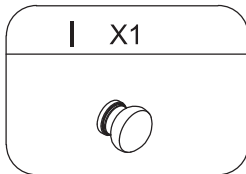
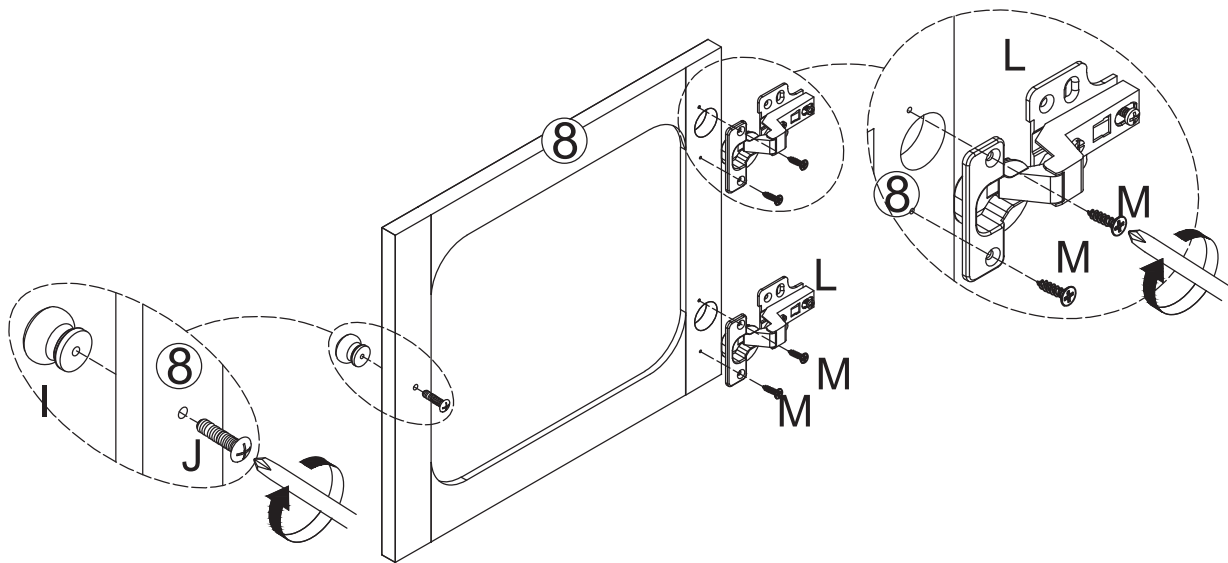

11 x2

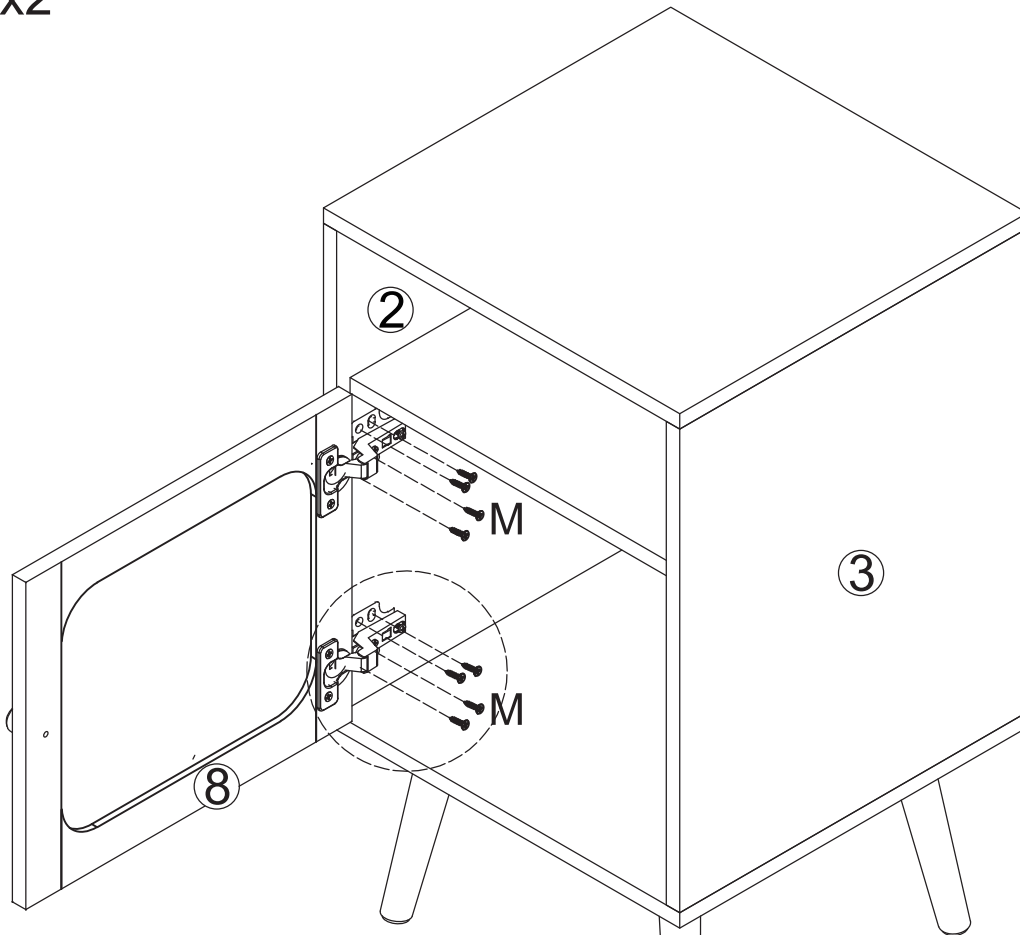

If the door can't close, please adjust the hinges.

This is used to adjust the door panel in the up and down direction.

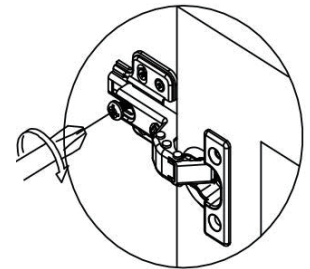
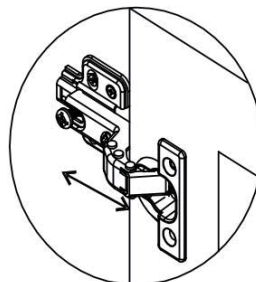
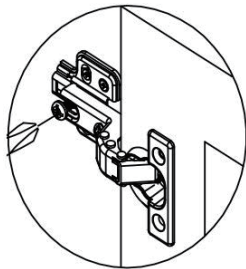
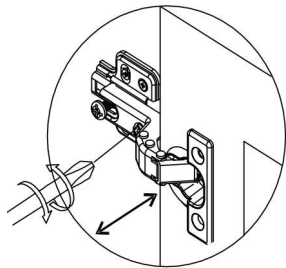

This is used to adjust the door panel in the front and back direction: Loosen the screw first, and then tighten screw after adjusting the door panel to the proper position.

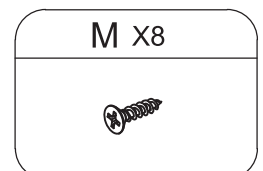

12 x2

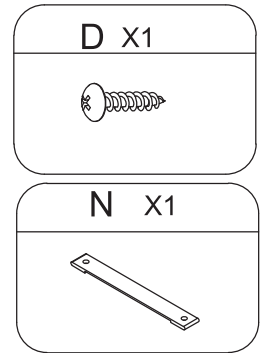
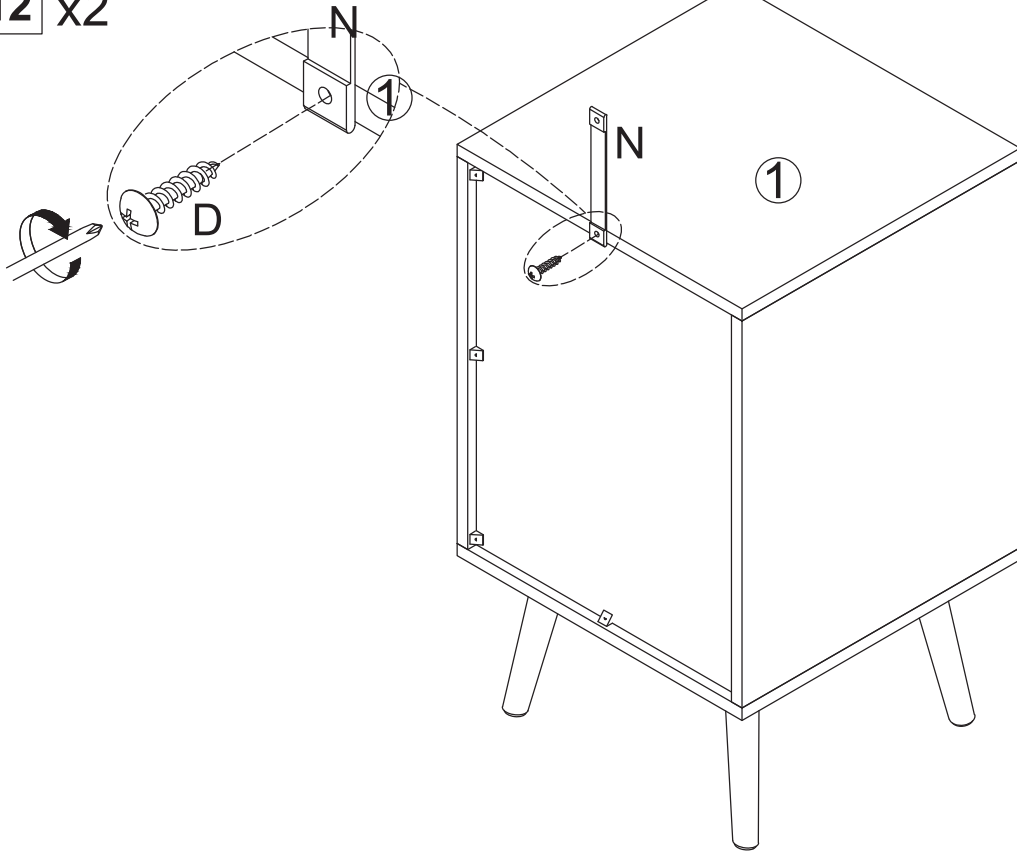

13 x2

