

Assembly Instructions

*** NOTICE BEFORE ASSEMBLY ***

Please choose the **CHAISE** will be on the **LEFT** or **RIGHT** hand side.

#Assembly Instruction 1:CHAISE ON THE LEFT

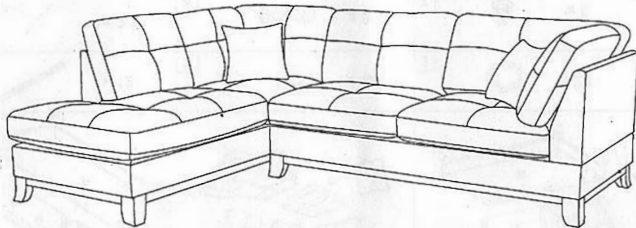

PARTS LIST

BOX-1		BOX-2	

Assembly Instructions

*** NOTICE BEFORE ASSEMBLY ***

Please choose the **CHAISE** will be on the **LEFT** or **RIGHT** hand side.

#Assembly Instruction 1:CHAISE ON THE RIGHT

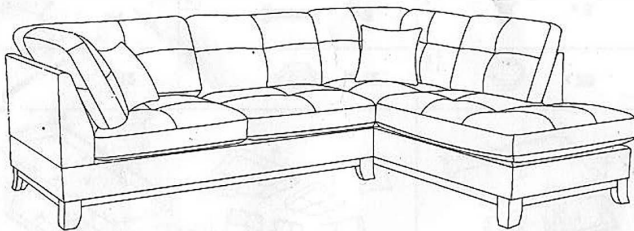

Before assembly, open both Box 1 and Box 2 to switch between Part C&H&L and Part F&G&R. And you will get the direction of right chaise.

PARTS LIST

BOX-1		BOX-2	

1	x 12	2	x 12	3	x 20	4	x 20
5	x 2	6	x 8	7	x 8	8	x 2

BEFORE ASSEMBLY

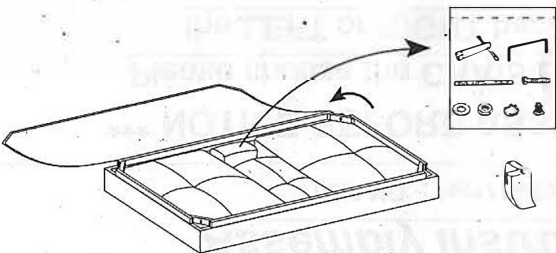

Open up the Velcro of Non-Woven Fabric cover on the bottom of the seat frame to remove seat cushions, back cushions and pillow.

PLEASE REMOVE ALL PARTS FROM SEAT FRAMES AND BACKS BEFORE ASSEMBLY

CHAISE ON THE RIGHT

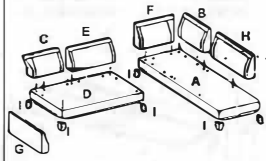

CHAISE - BOX 1

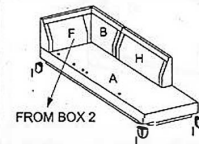

SOFA - BOX 2

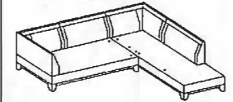
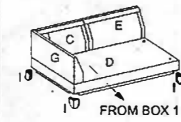

CHAISE ASSEMBLY INSTRUCTION - BOX 1

STEP 1- INSERT THREADED RODS INTO SEAT BACKS

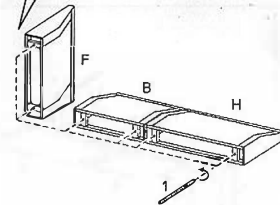
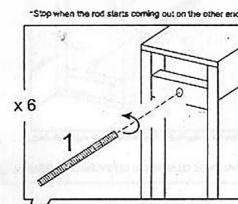

STEP 2- MOUNT SEAT BACKS INTO THE SEAT FRAME

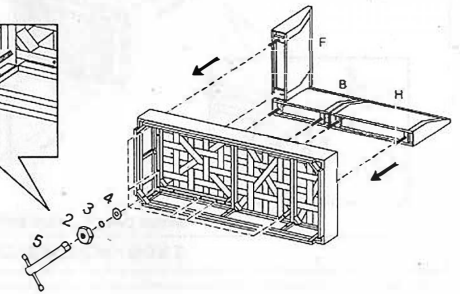
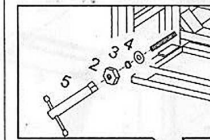

STEP 3- PUT BACK THE FABRIC COVER AND INSERT LEGS

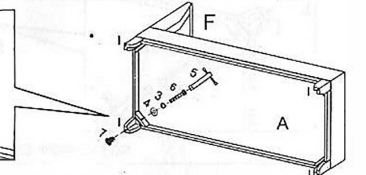
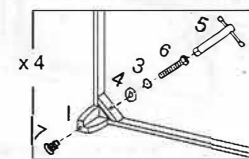

SOFA ASSEMBLY INSTRUCTION - BOX 2

STEP 1- INSERT THREADED RODS INTO SEAT BACKS

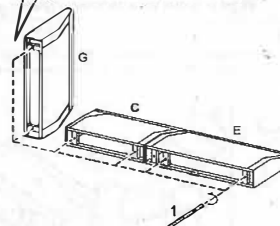
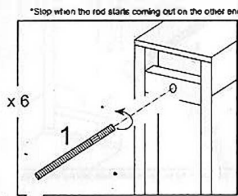

STEP 2- MOUNT SEAT BACKS INTO THE SEAT FRAME

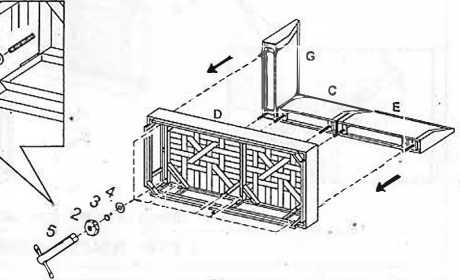
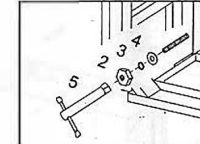

STEP 3- PUT BACK THE FABRIC COVER AND INSERT LEGS

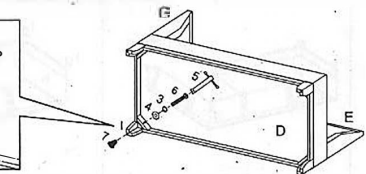
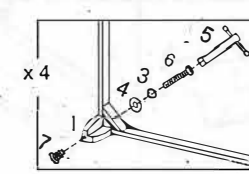

Back "E" assembly only need to use the two bolts, but there are three holes, to assemble the sofa in different side need to use a different hole.

OPTIONAL: CHAISE + SOFA (SECTIONAL)

STEP1-INSERT THE "N" SHAPE HANGER INTO THE ONE-ARM CHAISE FRAME AND ONE-ARM SOFA FRAME TO ATTACH TOGETHER.

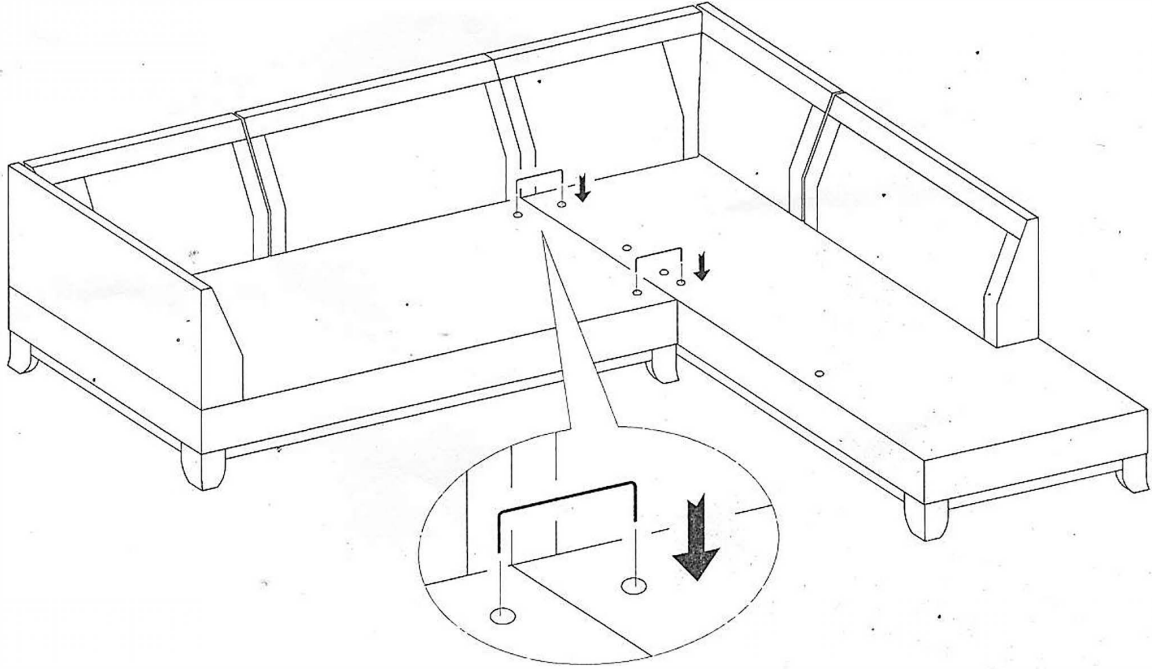

CHAISE + SOFA (SECTIONAL)

STEP1-INSERT THE "N" SHAPE HANGER INTO THE ONE-ARM CHAISE FRAME AND ONE-ARM SOFA FRAME TO ATTACH TOGETHER.

