

BED

Assembly Manual

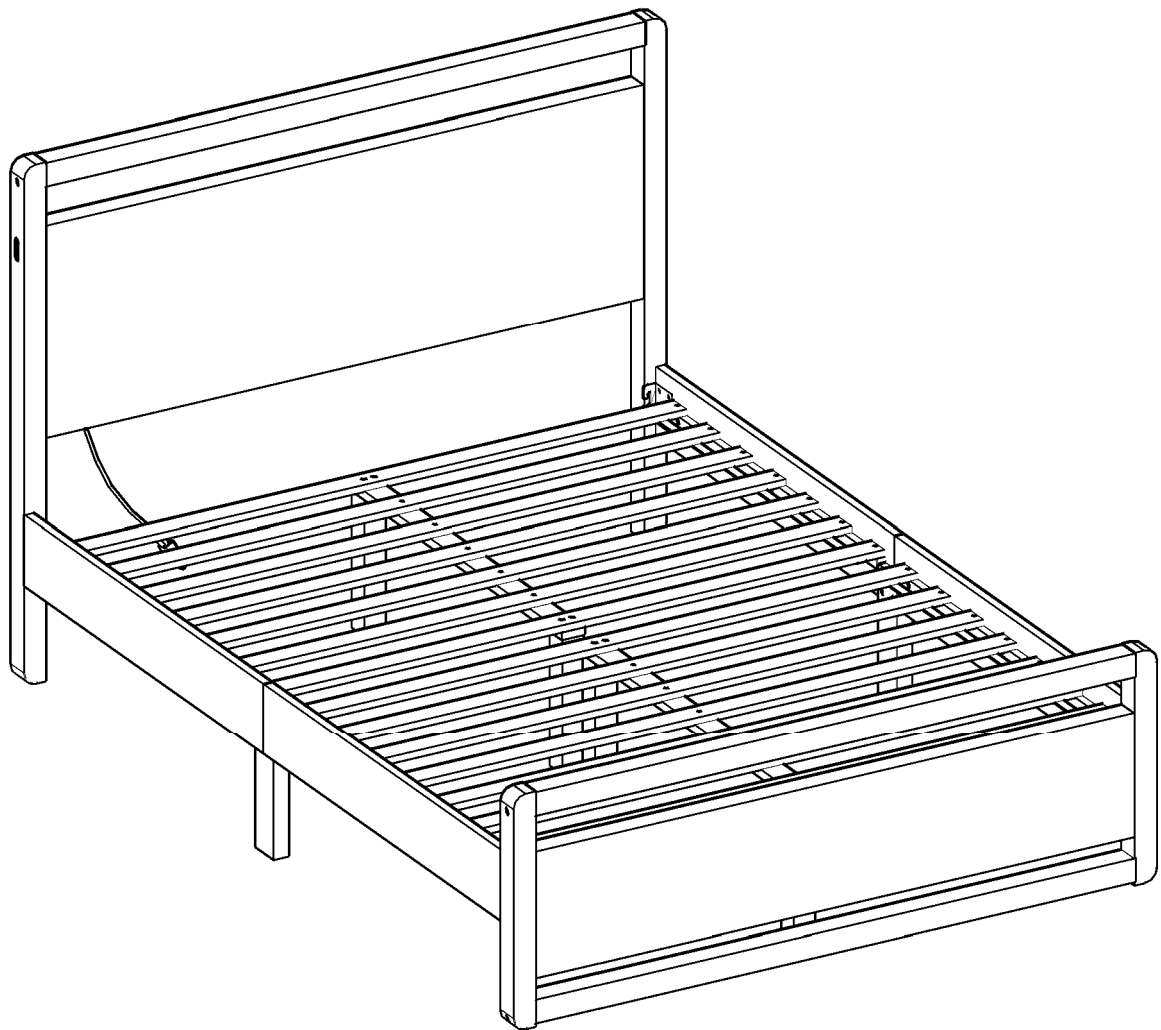

 **CAUTION**

THIS ASSEMBLY MANUAL CONTAINS IMPORTANT SAFETY INFORMATION.
PLEASE READ AND KEEP FOR FUTURE REFERENCE.

ASSEMBLY INSTRUCTIONS

Read these instructions carefully and keep for future reference. Refer to parts inventory for guidance, and ensure you have all pieces before starting.

When assembling, place all parts on a soft, clean, and flat surface such as a carpet to prevent scratches.



Structural integrity is only guaranteed if all bolts are installed and properly tightened.



TIME

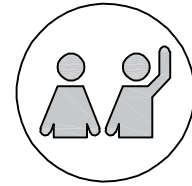

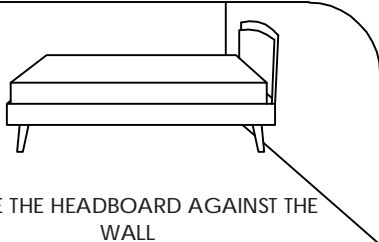

2 OF PEOPLE



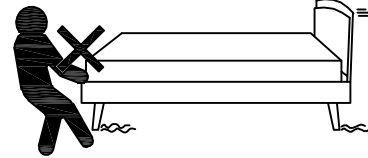



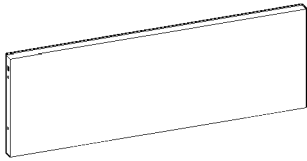
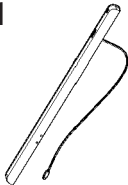
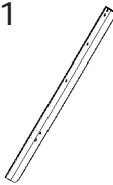

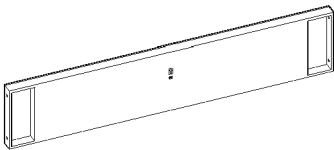
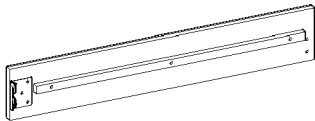
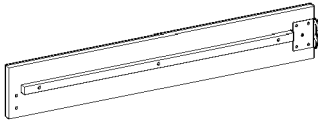
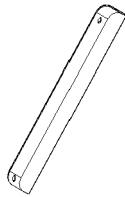
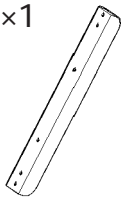

PLACE THE HEADBOARD AGAINST THE WALL

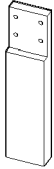
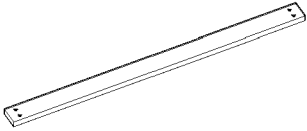

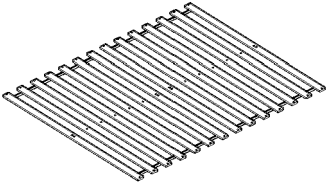
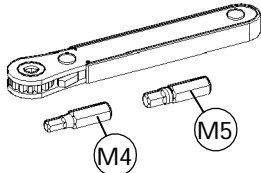
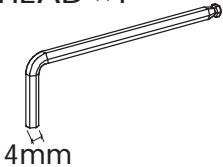
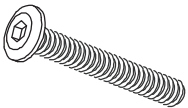
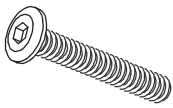
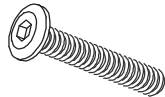
DO NOT DRAG BED, ALWAYS LIFT WITH AT LEAST TWO PEOPLE BEFORE MOVING

<p>1. HEADBOARD ×1</p> 	<p>2. HEADBOARD LEG -USB (LEFT) ×1</p> 	<p>3. HEADBOARD LEG (RIGHT) ×1</p> 
<p>4. HEADBOARD & FOOTBOARD WOOD ×3</p> 	<p>5. FOOTBOARD ×1</p> 	<p>6. SIDE RAIL (LEFT) ×2</p> 
<p>7. SIDE RAIL (RIGHT) ×2</p> 	<p>8. FOOTBOARD LEG (LEFT) ×1</p> 	<p>9. FOOTBOARD LEG (RIGHT) ×1</p> 

Please read through the instructions below to familiarize yourself with the parts and steps before assembly.

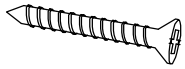
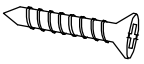
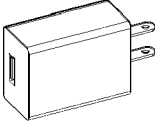
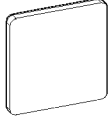
<p>10.SIDE RAIL LEG ×2</p> 	<p>11.CENTER RAIL ×2</p> 	<p>12.CENTER LEG ×4</p> 
<p>13.SLATS ×7 (2 Set)</p> 	<p>A.RATCHET TOOL ×1</p> 	<p>B.M4 ALLEN KEY LONG BALL HEAD ×1</p> 
<p>C.JCBC BOLT M6 X 70MM ×6</p> 	<p>D.JCBC BOLT M6 X 50MM ×8</p> 	<p>E.JCBC BOLT M6 X 40MM ×8</p> 
<p>F.JCBC BOLT M6 X 25MM ×8</p> 	<p>G.WOOD DOWEL M8 X 30MM ×6</p> 	<p>H.M6 SPRING WASHER ×14</p> 
<p>I.M6 FLAT WASHER ×8</p> 	<p>J.M6 FLAT WASHER (1/4" X 16 X 1.0) ×6</p> 	<p>K.WOOD SCREW M4 X 25MM ×38</p> 
<p>L.WOOD SCREW M3.5 X 16MM ×1</p> 	<p>M.POWER ADAPTER ×1</p> 	<p>N.FOOT PADS ×10</p> 

Please read through the instructions below to familiarize yourself with the parts and steps before assembly.

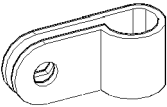
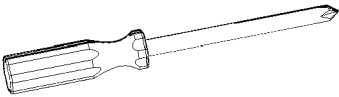
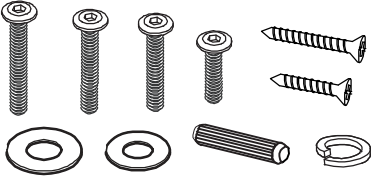
<p>O.CABLE CLAMP ×1</p> 	<p>Not Included</p>  <p>Phillips Head Screwdriver</p>	<p>Extra Hardware</p> 
---	--	---

Please read through the instructions below to familiarize yourself with the parts and steps before assembly.

Before you begin:

1. Check if you have received all parts using the diagram on this page. Do not start the assembly process until all parts are present.
2. Do not discard any of the packaging until you are certain that you have all the necessary parts for the assembly.

ASSEMBLY INSTRUCTIONS

1 Please lay all parts on a soft and smooth surface to assemble.

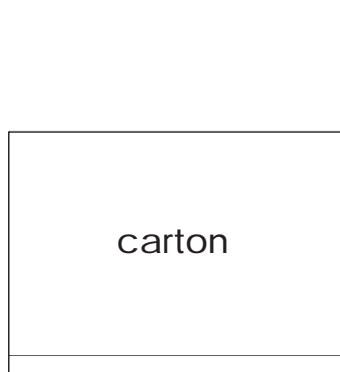
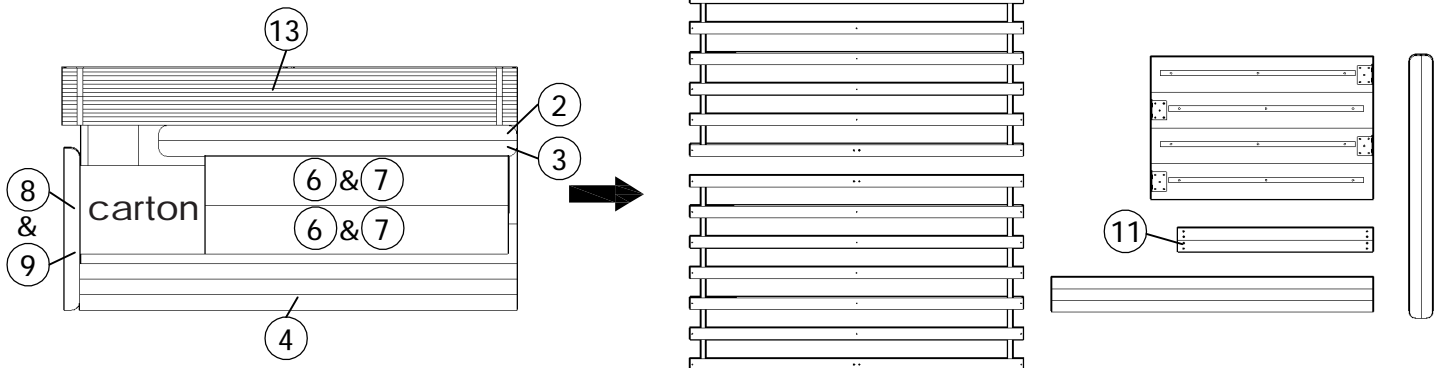

- | | | |
|-----|------|------|
| A×1 | F×8 | K×38 |
| B×1 | G×6 | L×1 |
| C×6 | H×14 | M×1 |
| D×8 | I×8 | N×10 |
| E×8 | J×6 | O×1 |

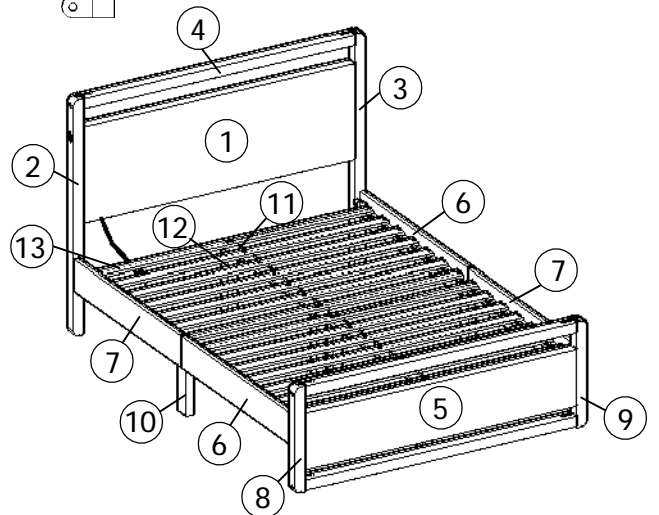
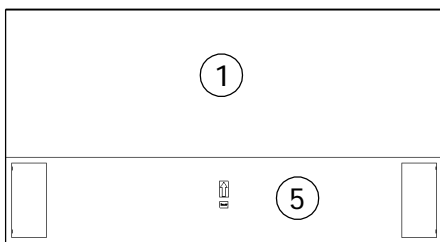
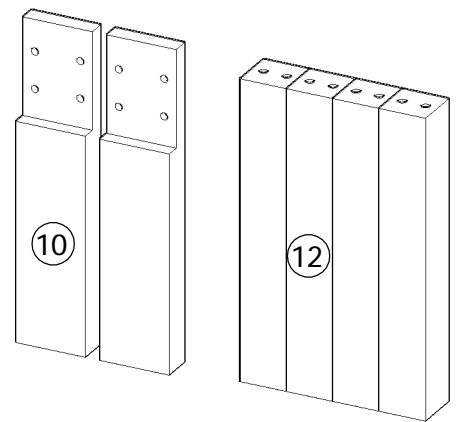

- 2** Attach side rail leg (10) to side rail (left) (6) and side rail (right) (7), using JCBC Bolt M6 X 25MM (F) and M4 Ratchet Tool (A). Fully tighten.
 Note: Before assembled the side rail, please ensure that the side rail laminated veneer lumber LVL is parallel.

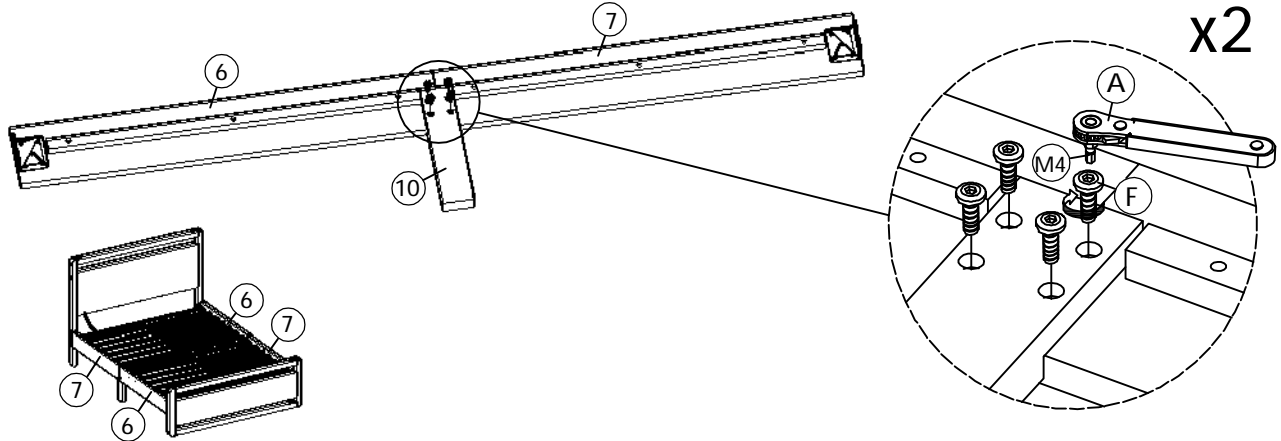

- 3** Attach headboard leg (left) (2) and headboard leg (right) (3) to the headboard (1) and headboard&footboard wood (4). Firstly insert the headboard leg (left) (2) USB into the hole of the headboard (1), using Wood Dowel M8 X 30MM (G), JCBC Bolt M6 X 70MM (C), M6 Spring Washer (H), M6 Flat Washer (J), M4 Allen Key Long Ball Head (B). Fully tighten.

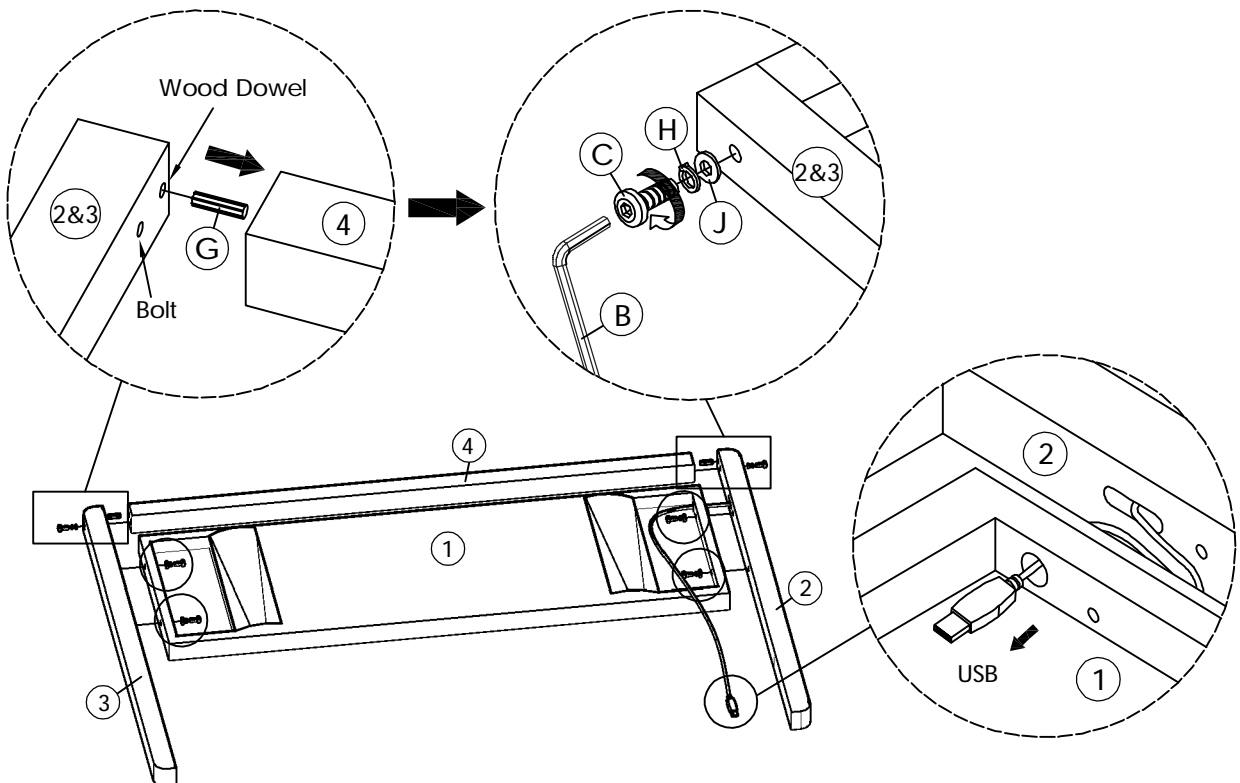

-
- 4** Attach the assembled headboard remaining part, using JCBC Bolt M6 X 40MM (E), M6 Spring Washer (H), M6 Flat Washer (I), M4 Ratchet Tool (A). Fully tighten.

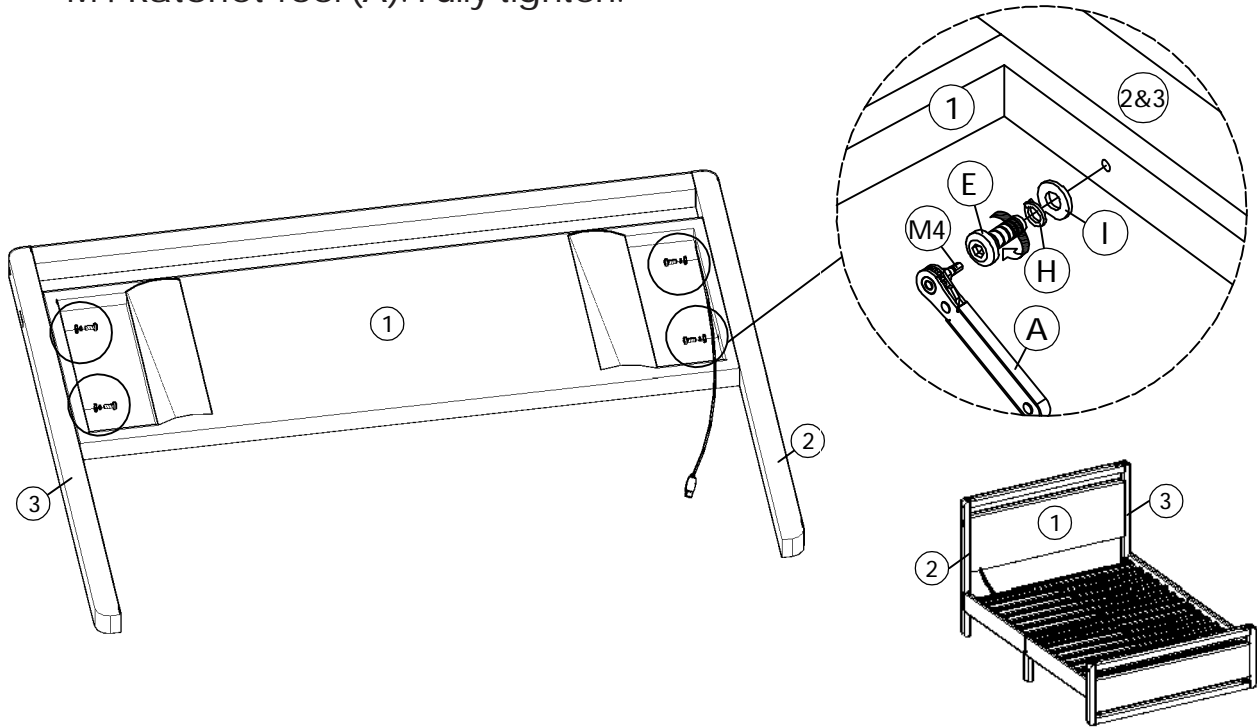

- 5** Affix the Cable Clamp (O) to headboard USB using Wood Screw M3.5 X 16MM (L) and Phillips Head Screwdriver (Not Included). Fully tighten.

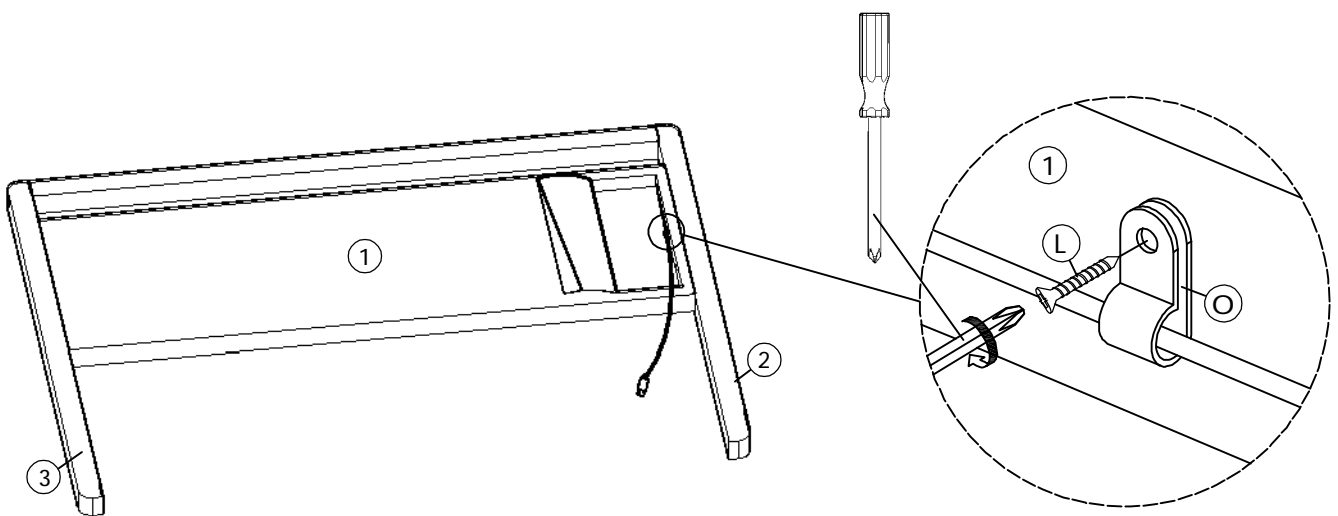

- 6** Attach footboard leg (left) (8) and footboard leg (Right) (9) to headboard & footboard wood (4), using Wood Dowel M8 X 30MM (G).

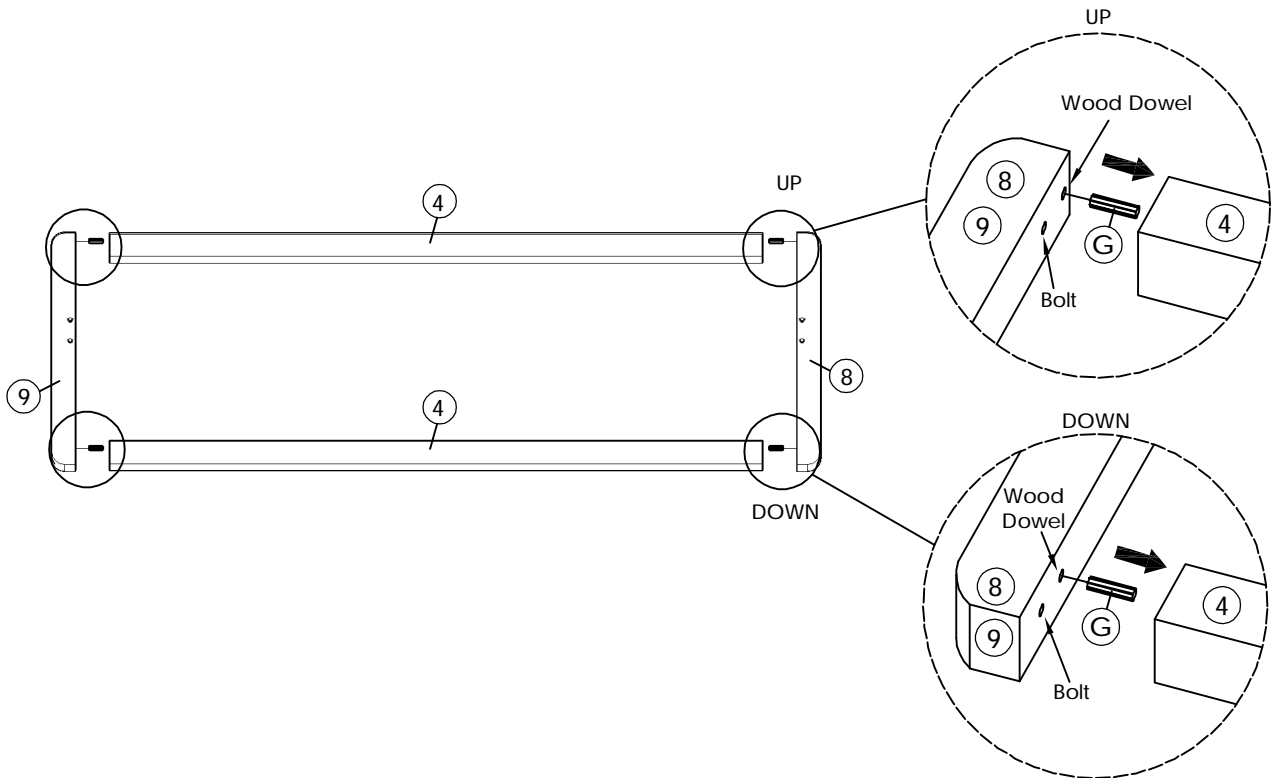

- 7** Attach assembled footboard leg (left) (8) and footboard leg (Right) (9) to headboard & footboard wood (4), using JCBC Bolt M6 X 70MM (C), M6 Spring Washer (H), M6 Flat Washer (J), M4 Allen Key Long ball head (B). Do Not Fully tighten Bolts.

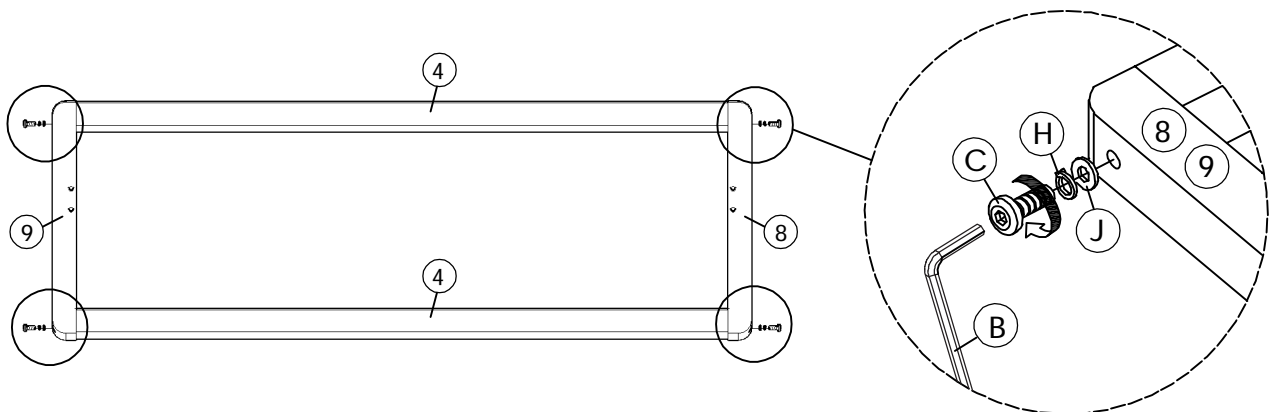

- 8** Attach footboard (5) to assembled footboard Leg (left) (8) and footboard leg (Right) (9) , using JCBC Bolt M6 X 40MM (E), M6 Spring Washer (H), M6 Flat Washer (I) and M4 Ratchet Tool (A). Fully tighten.

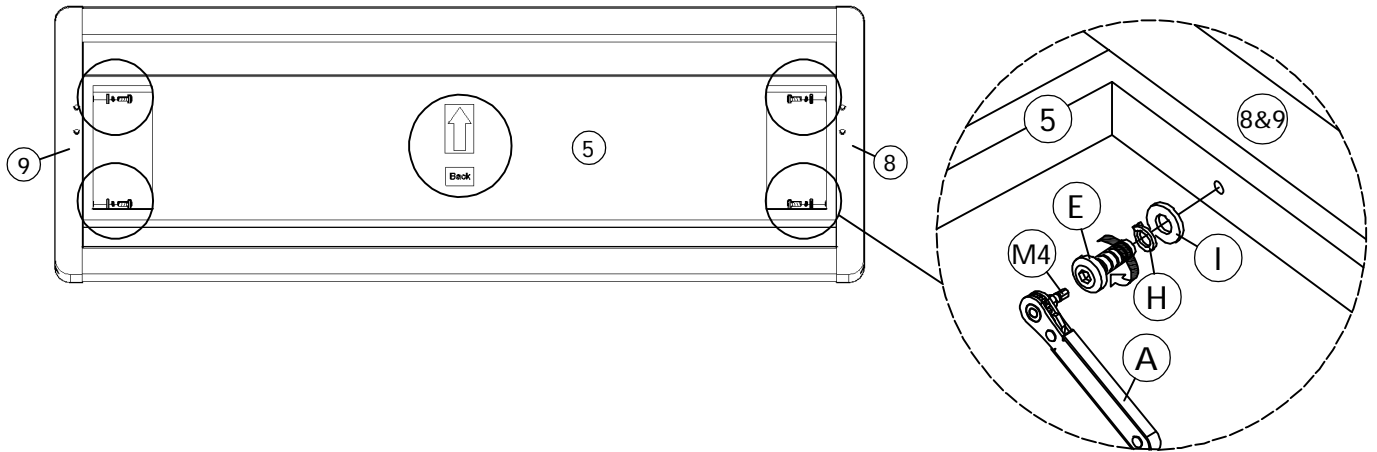

- 9** Attach assembled side rail (left) (6) and side rail (right) (7) to headboard leg (2,3) and footboard leg (8,9), using M5 Ratchet Tool (A). Fully tighten. Note: Loosen the pre-attached bolt slightly, after attach the side rail, fully tighten the pre-attached bolt.

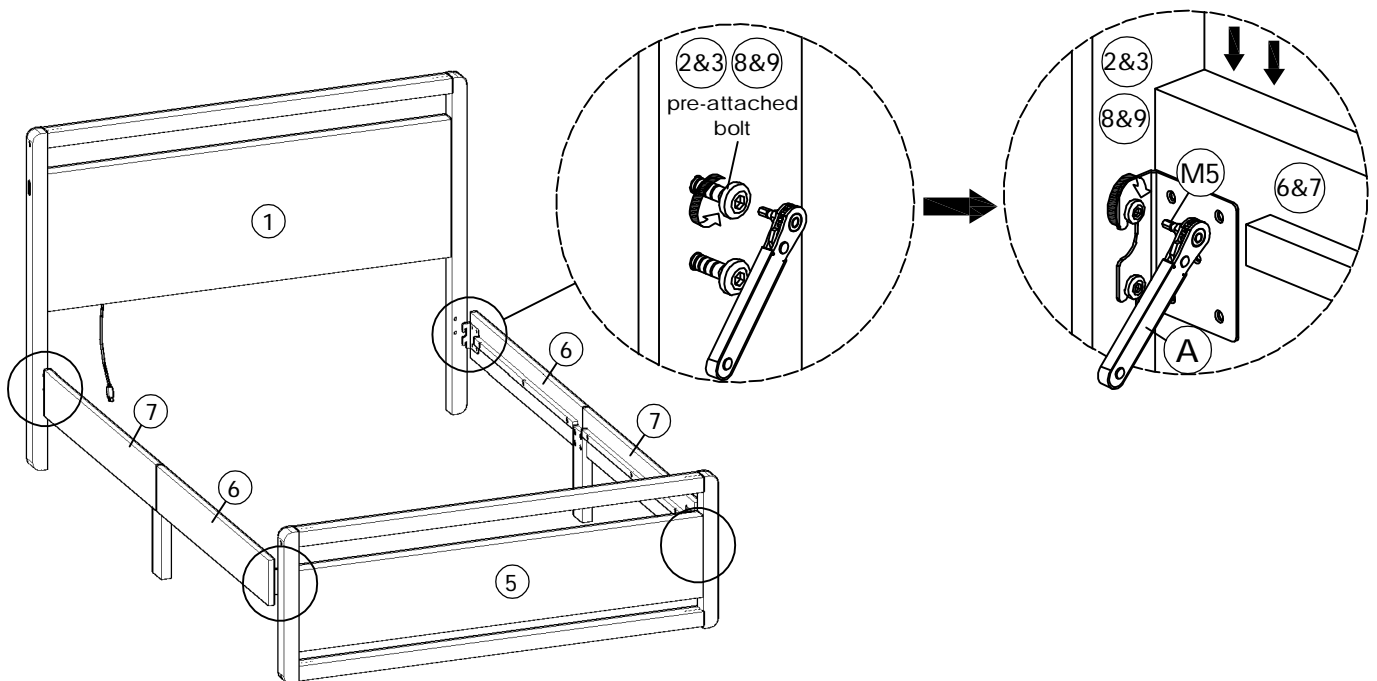

- 10** Attach center leg (12) and slats x7 (2 Set) (13) to center rail (11), using JCBC Bolt M6 X 50MM (D) and M4 Ratchet Tool (A). Fully tighten.
Note: Paste the Foot Pads (N) underneath the center leg (12) (optional).

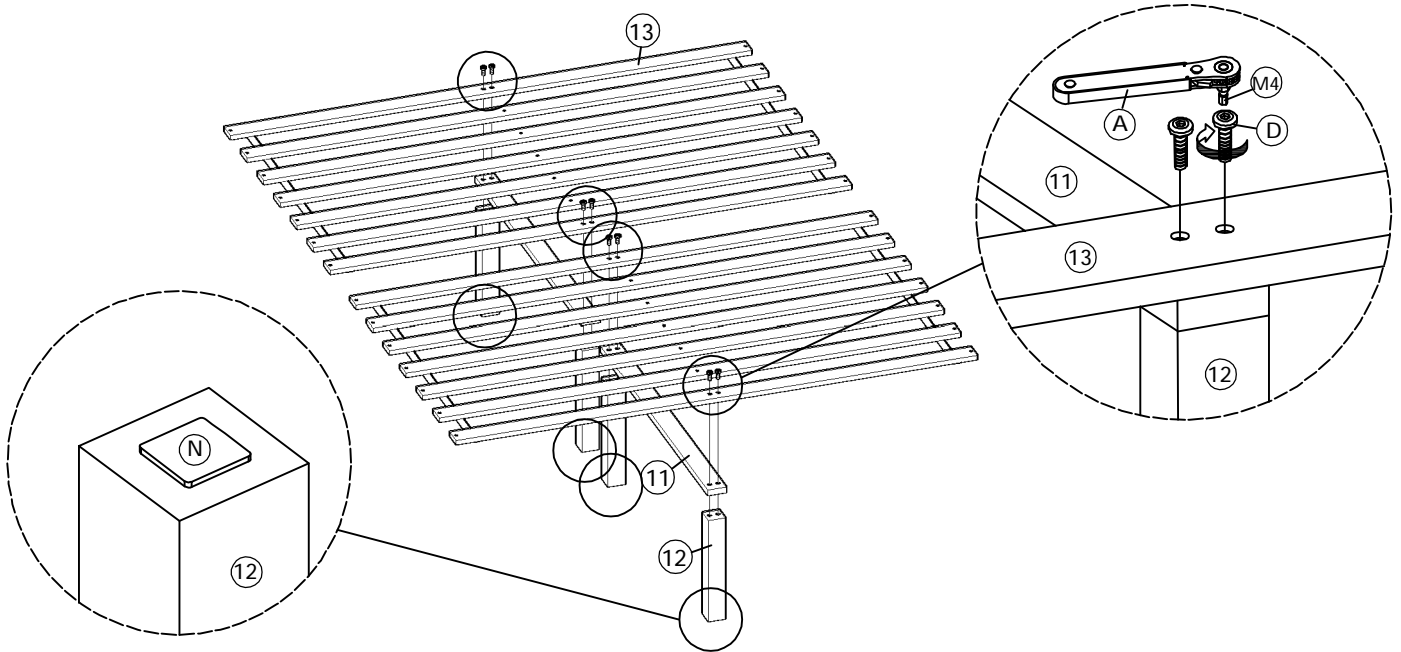

- 11** Attach slats x7 (2 Set) (13) to side rail (left) (6) and side rail (right) (7), using Wood Screw M4 X 25MM (K) and Phillips Head Screwdriver (Not Included). Fully tighten.
Note: Please fully tighten the eight side screws that shown in below circled, then fully tighten the others screws.

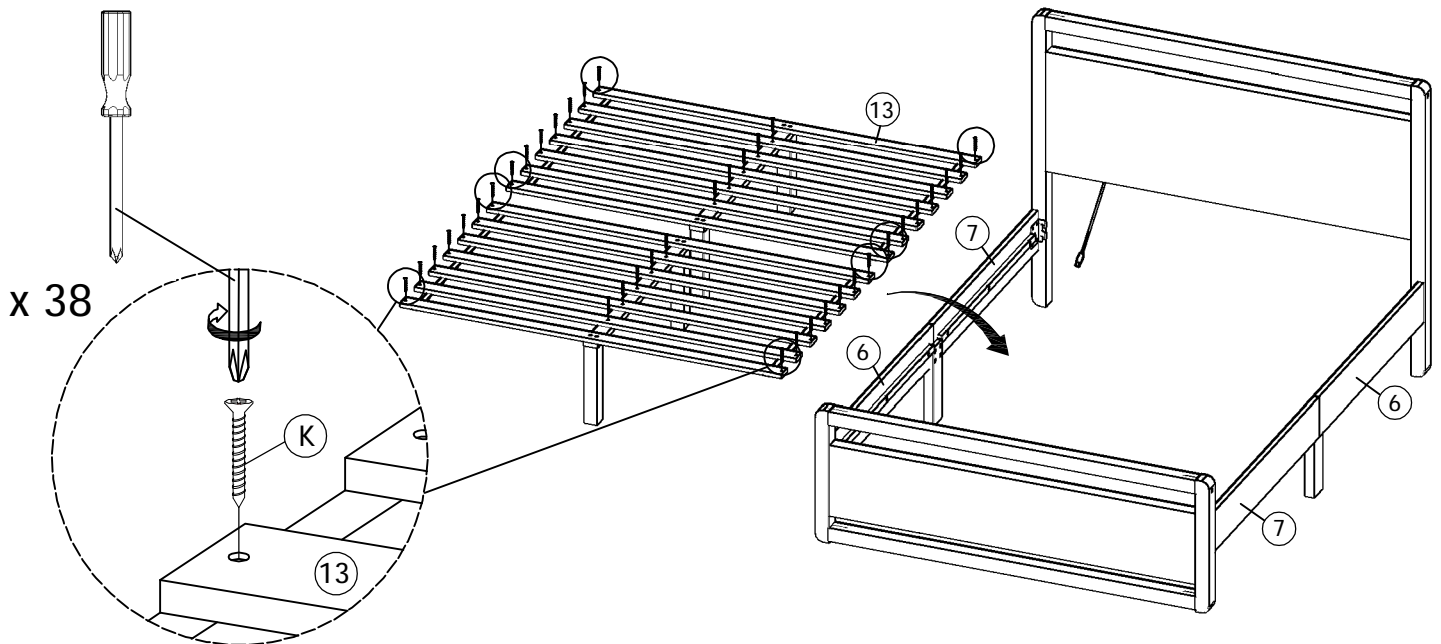

12 Attach USB into power adapter (M) .

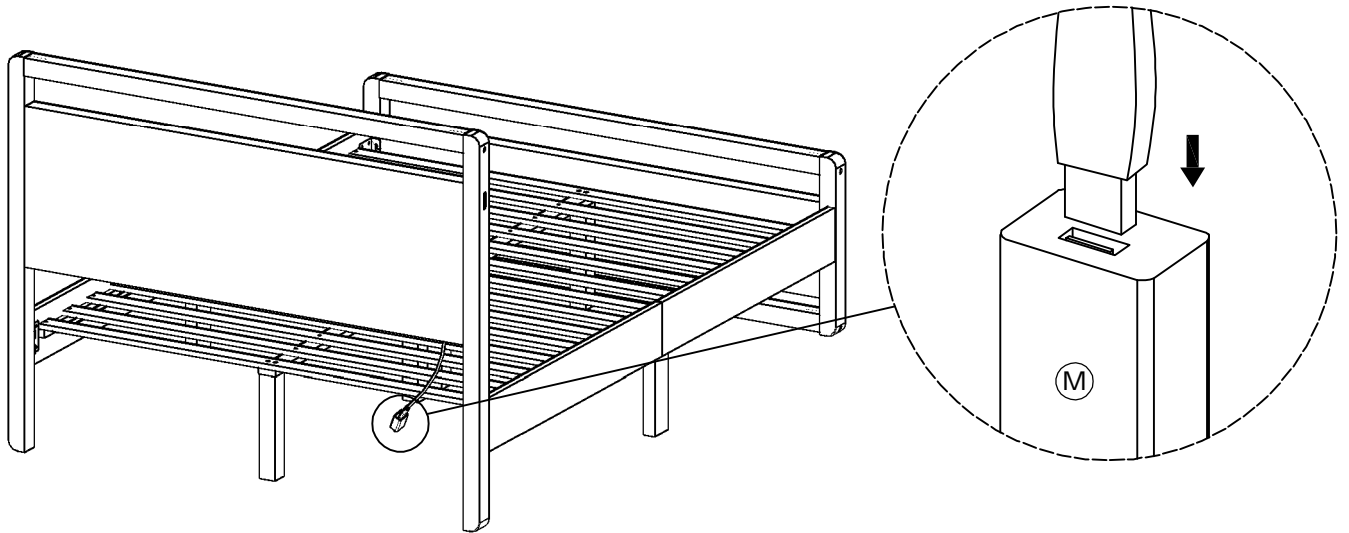

13 Paste the Foot Pads (N) underneath the below circled (optional).

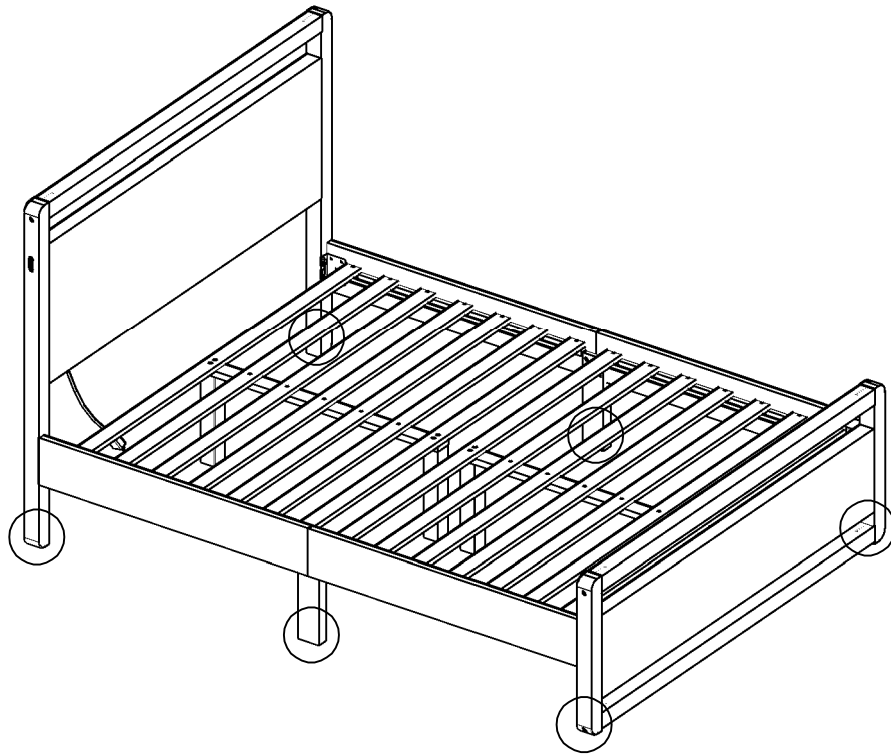

14 Assembly Completed. Enjoy.

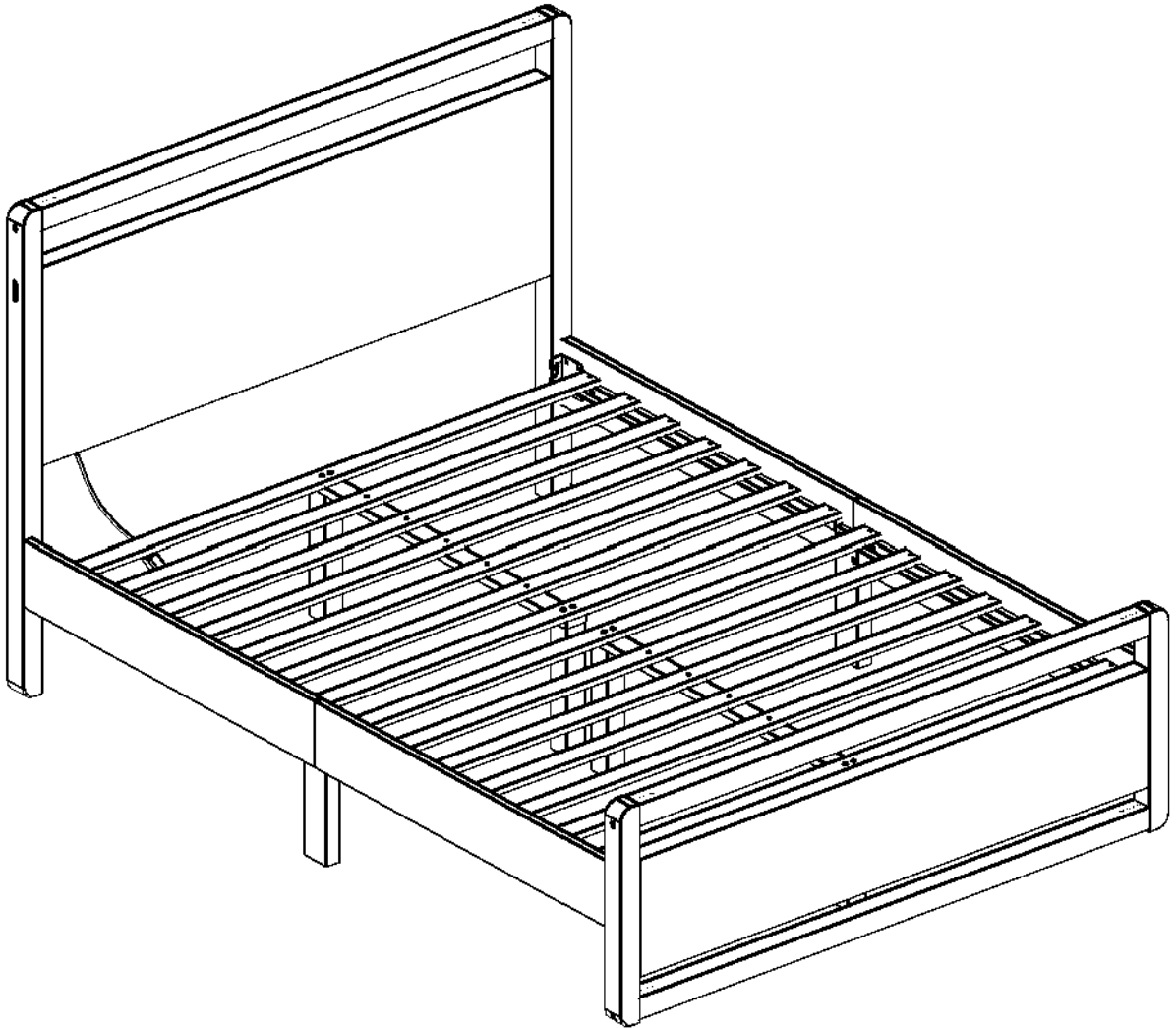

PRODUCT WARRANTY

- 1-year limited on cover against splitting, peeling, and/or tearing.
- 1-year limited on internal and external frame structure.

Contact us:

We make all efforts to guarantee that the products you receive are in excellent condition. If there are any parts missing or damaged, the Customer Service Team will be happy to provide free replacements for you. We have professional warehouses where the current inventory of parts is enough so that they will arrive in your hands as fast as possible.

Assistance with assembly or product details is available; don't hesitate to get in touch with us to get priority service.