

## Assembly Instruction

TV Stand with Shelf and Storage

00:20

Approx. 20 minutes





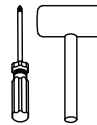

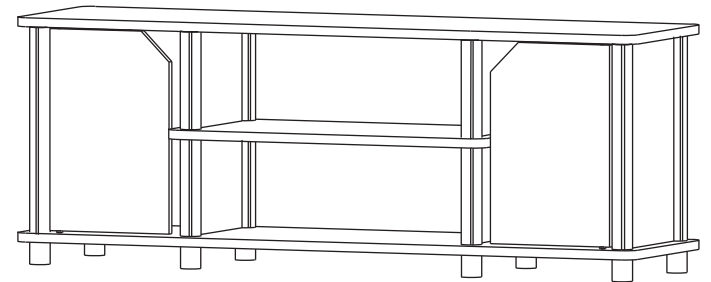

Recomm. 2 Persons



Tool Required



## HARDWARE AND PART LIST

NO	HARDWARE LIST	QTY	NO	PART LIST	QTY
1.	ROUND LONG POLE WITH GROOVE 	4 PCS	A.	TOP PANEL	1 PC
2.	ROUND SHORT POLE WITH GROOVE 	8 PCS	B.	BOTTOM PANEL	1 PC
3.	ROUND LEG 	8 PCS	C.	SHELF PANEL	1 PC
4.	MAGNET 	2 PCS	D.	LEFT DOOR PANEL	1 PC
5.	FLAT HEAD SCREW 	2 PCS	E.	RIGHT DOOR PANEL	1 PC
6.	DOOR SPRING 	4 PCS	F.	BACK PANEL	2 PCS
7.	DOWEL 	8 PCS	G.	LARGE SIDE PANEL	2 PCS
			H.	SMALL SIDE PANEL	4 PCS

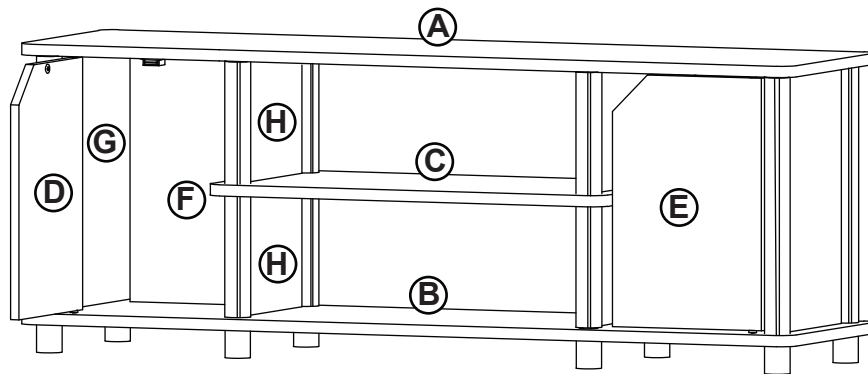

### USEFUL HINTS BEFORE YOU START:

1. Read each step carefully before starting.
2. It is important that each step is performed in correct order to avoid difficulties.
3. Identify, sort and count the parts before assembly.
4. Assemble your furniture on packaging cardboard to prevent scratch or damage.
5. Clean the product with mild cleanser using soft damped cloth. Do not use harsh or abrasive cleanser.
6. Using incompatible hardware might cause damage to product.

## STEP 8

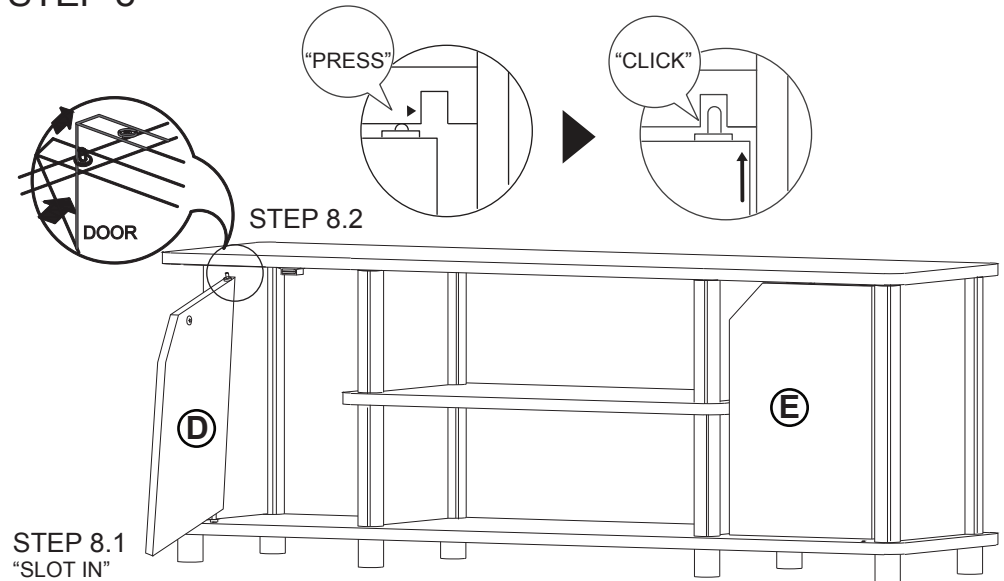

\*Repeat for right door

### Recommended Maximum Weight

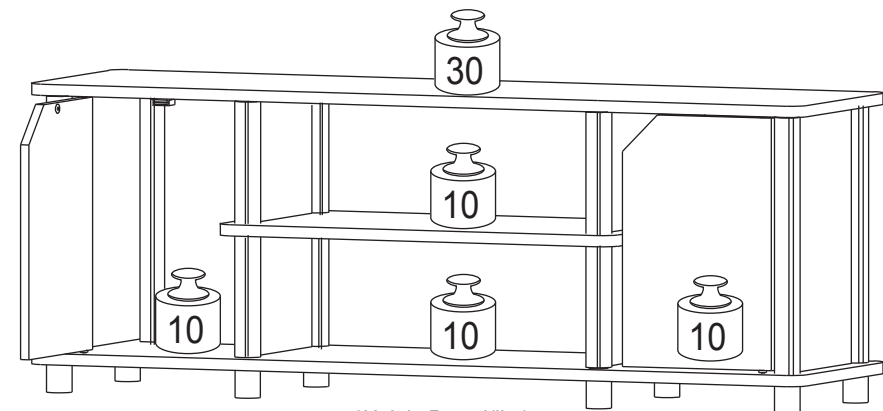

\*Unit in Pound(lbs)

### WARNING:

>This unit has been designed to support the maximum loads shown. Exceeding these load limits could cause sagging, instability, product collapse, and/or serious injury.

>DO NOT allow children to climb on unit.

>Put heavier items on lower shelves.

### STEP 6

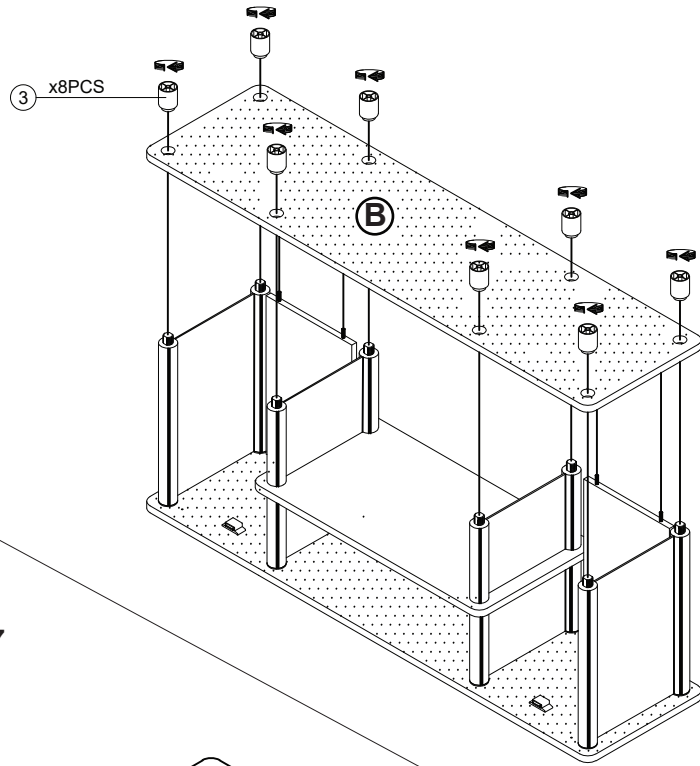

### STEP 7

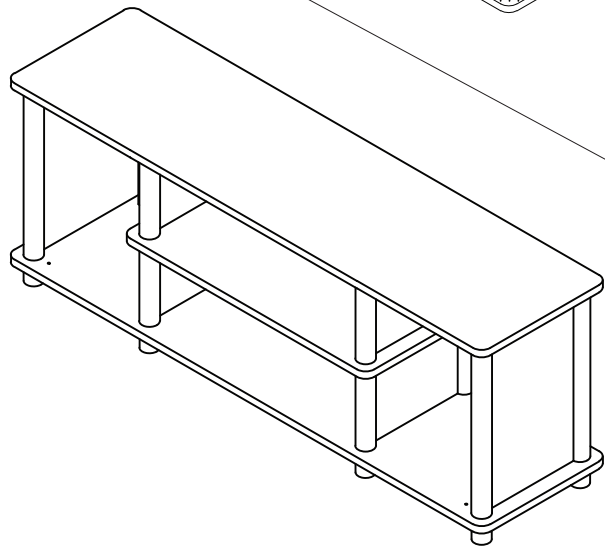

### STEP 1

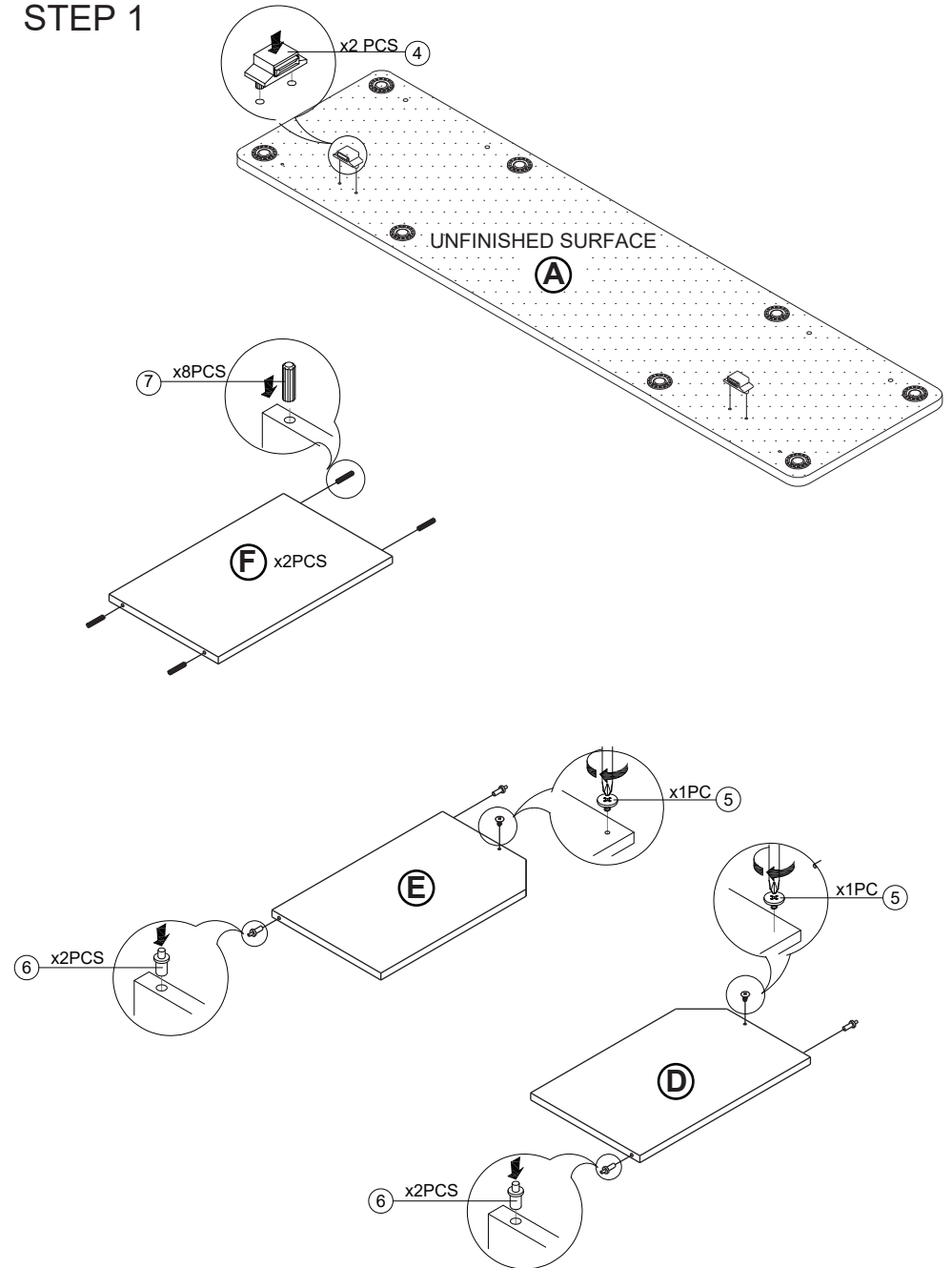

## STEP 2

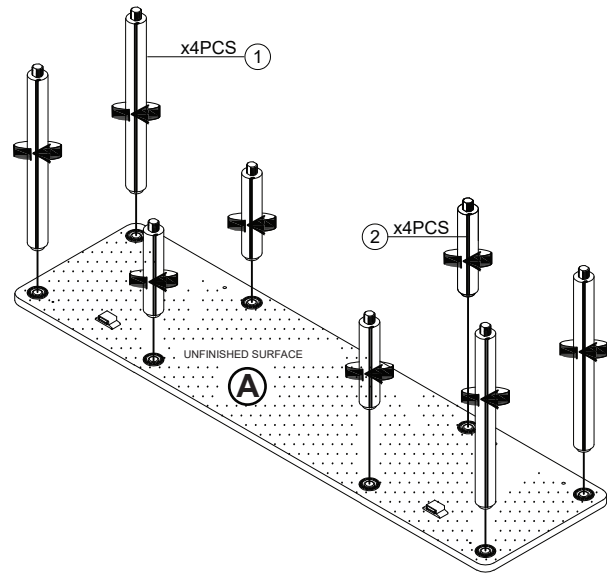

## STEP 3

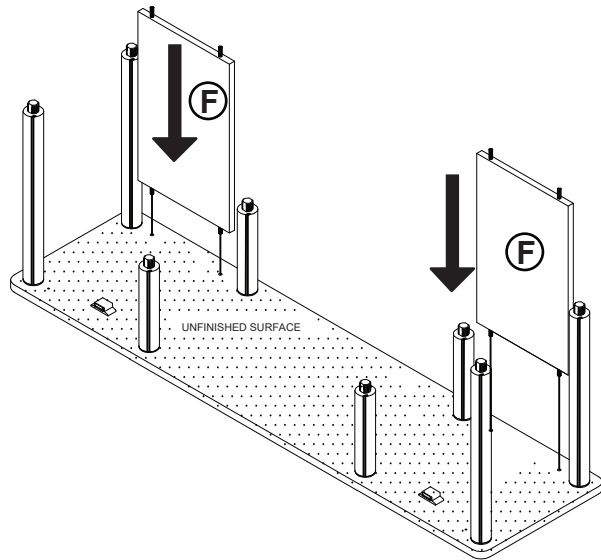

## STEP 4

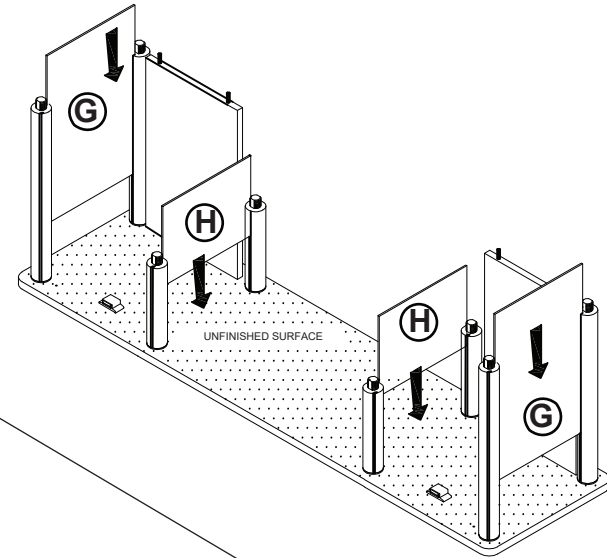

## STEP 5

