

# Sofa

Complete drawing display

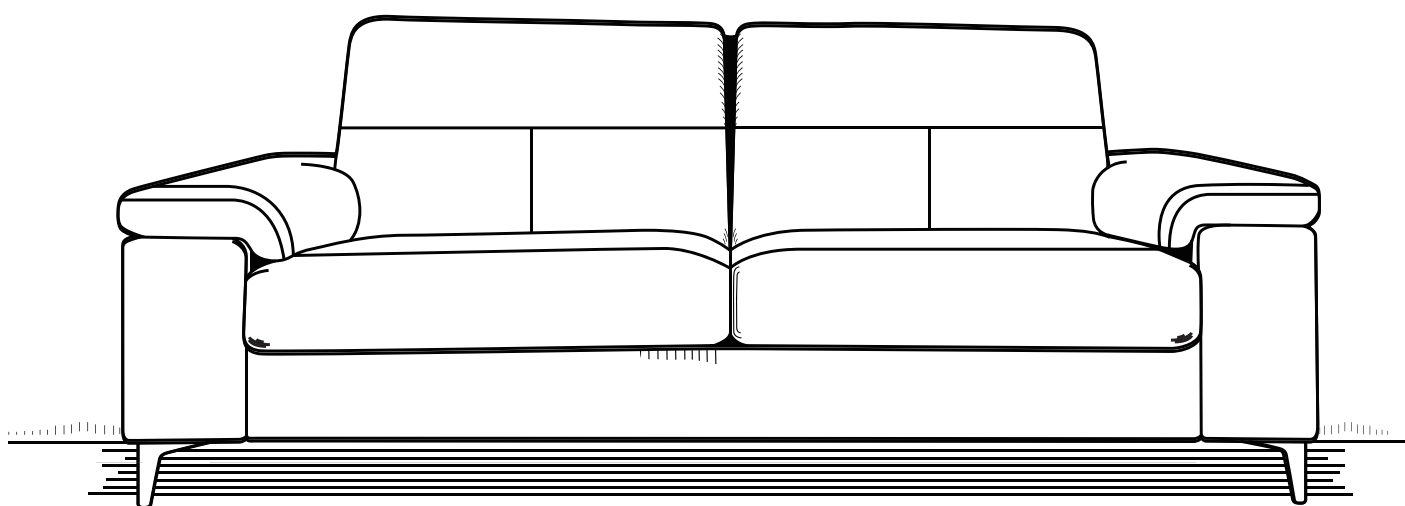

Model: C007-2三人位

# Safety And Care Advice

Important - Please read these instructions carefully before installing

Thank you for choosing our product.

Assemble and operate this product with care. Please read this instruction before beginning the installation, and carefully follow all instructions contained herein.

Use proper safety equipment during installation. Choose a clean, level, spacious assembly area. Avoid hard surfaces that may damage the product.

Take care when lifting. Ensure that you have all required contents for complete assembly.

Please keep the instruction manual properly

For inquiries, technical support, or warranty claims, please contact our customer services team. We hope this manual provides you with all the necessary information to use and maintain your product effectively. Happy life!

## Warnings :

Children are not allowed to assemble the product. During assembly, keep all small parts out of the reach of children as they may be fatal if swallowed or inhaled.

Do not place in front of a fire or other heat source.



After-sales  
service



Fast installation



Teamwork  
Recommended



The product parts are packed in two separate cartons. Please wait to receive both complete cartons before proceeding with the installation.

## Maintenance and Cleaning Methods

1. Regular Vacuuming: Make it a habit to vacuum your fabric sofa regularly, at least once a week, to remove dust, dirt, and crumbs. Use a soft brush attachment to prevent damage to the fabric.

2. Spot Cleaning: Deal with spills and stains immediately to prevent them from setting into the fabric. Blot the spill with a clean cloth or paper towel to absorb as much liquid as possible, then use a mild detergent mixed with water to gently clean the area. Always test any cleaning solution on a hidden area of the sofa first to ensure it doesn't cause discoloration.

3. Professional Cleaning: Consider having your fabric sofa professionally cleaned at least once a year, especially if it's heavily used or if you have pets. Professional cleaners have the expertise and equipment to deep clean the fabric without causing damage.



4. Fluff and Rotate Cushions: Regularly fluff and rotate the cushions on your sofa to ensure even wear and maintain their shape. This will help prevent sagging and prolong the life of the sofa.

5. Protect from Sunlight and Pets: Position your fabric sofa away from direct sunlight to prevent fading and discoloration. If you have pets, consider using a protective cover or blanket to minimize damage from claws and hair.

By following these maintenance and cleaning tips, you can keep your fabric sofa looking fresh and inviting for years to come.

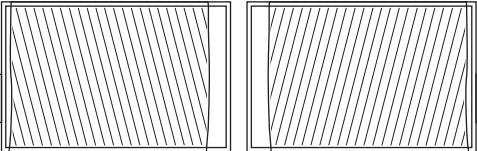
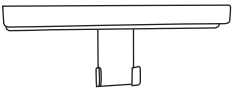
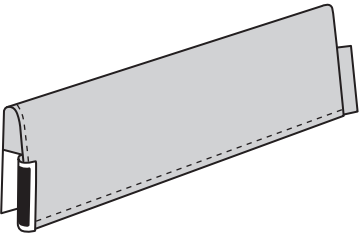
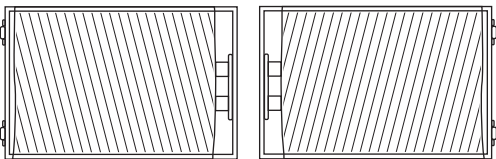

# Parts List

The parts list is shown below

illustration	description	quantity
	Backrest	A×1
	Fixed support	B×2
	Backrest cover	C×1
	Seat frame	D×1
	Long support leg	E×1
	Short support leg	F×1



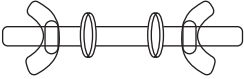
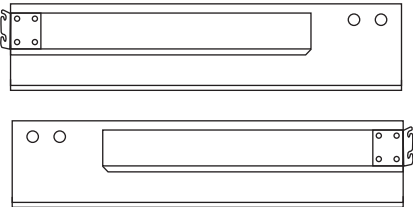

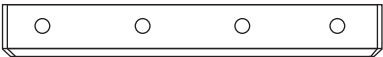
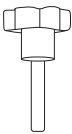
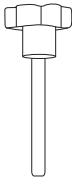
# Parts List

The parts list is shown below

illustration	description	quantity
	screw	G×4
	Front panel	H×1
	Front panel cover	I×1
	Connecting rod	J×1
	Short screw	K×4
	Long screw	L×2

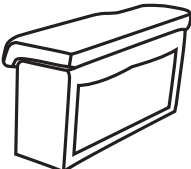
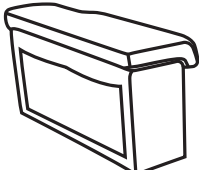
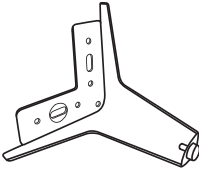
# Parts List

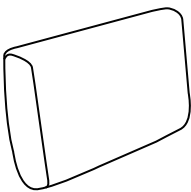
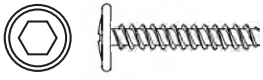
The parts list is shown below

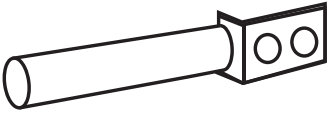
illustration	description	quantity
	Left armrest	M×1
	Right armrest	N×1
	Leg	O×4
	Seat cushion	P×2
	Back cushion	Q×2
	Bolt	R×12
	Wrench	S×1
	Leg	T×2

# Installation Procedure

Specific operations are shown in the following figure

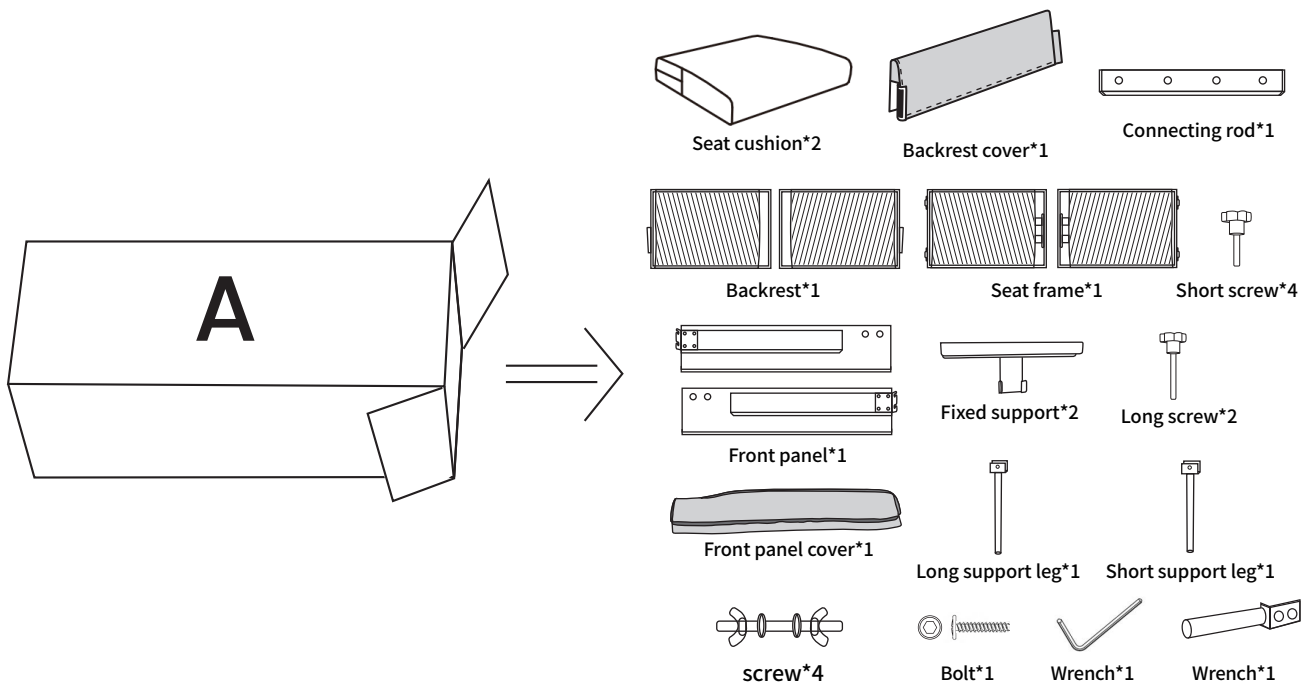

STEP 1: Take out the items in box A

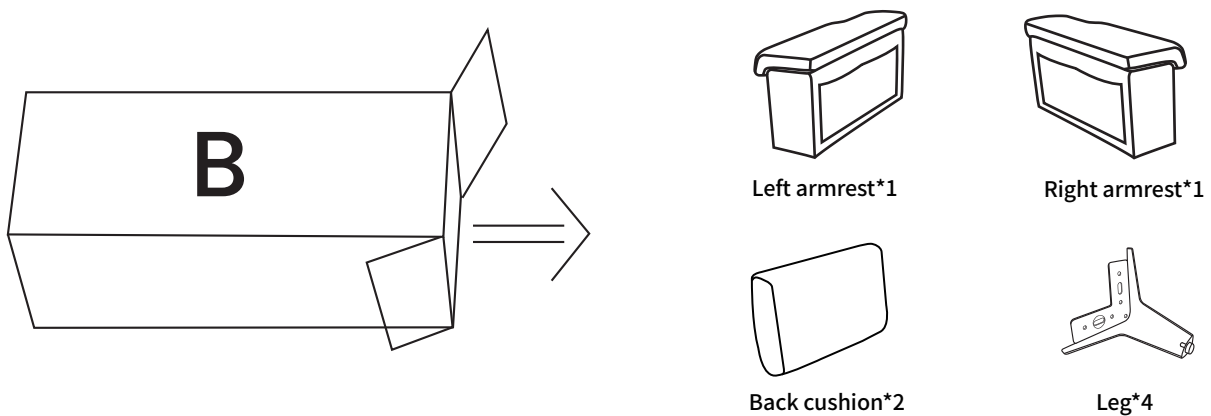

STEP 2: Take out the items in box B

# Installation Procedure

Specific operations are shown in the following figure

## Assmble 2 back cushions

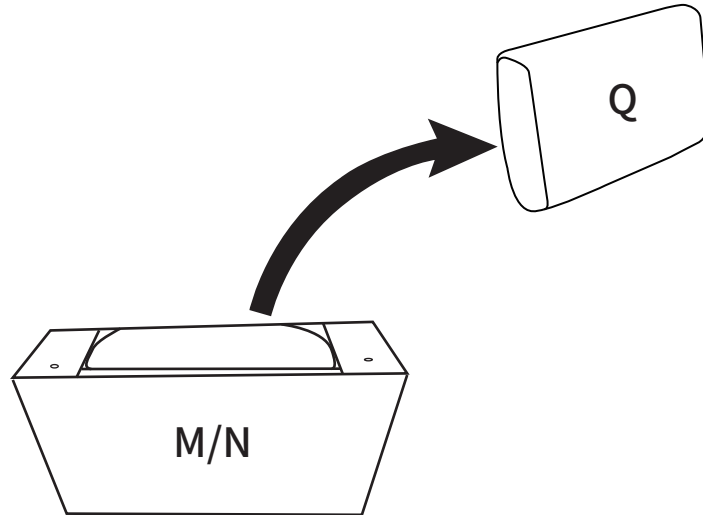

STEP 3: Remove the back cushions and Throw pillow from the inside of each arm.

## Assmble the 4 legs on the two armrest(M and N)

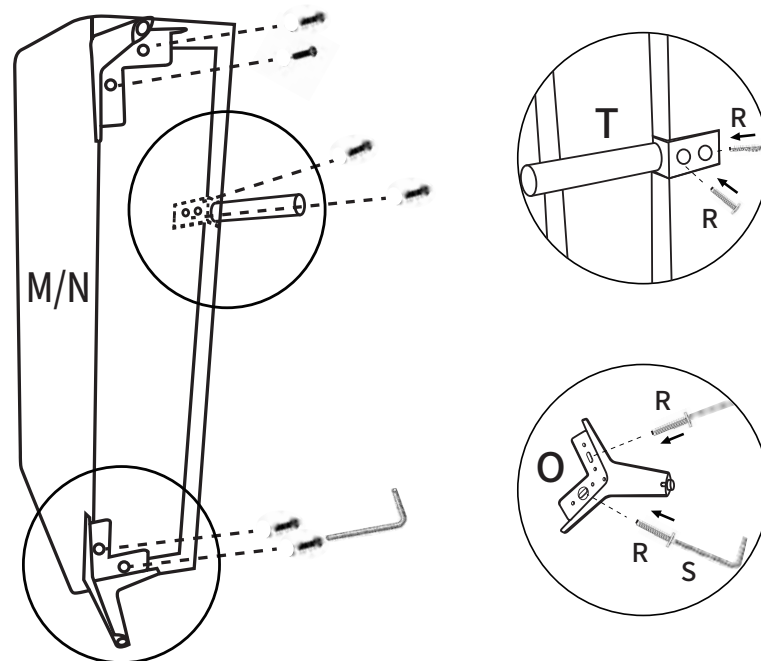

STEP 4: Remove the plastic caps on the bolts of each leg. Flip the arms upside down to screw the legs.

# Installation Procedure

Specific operations are shown in the following figure

## Assemble the front panel

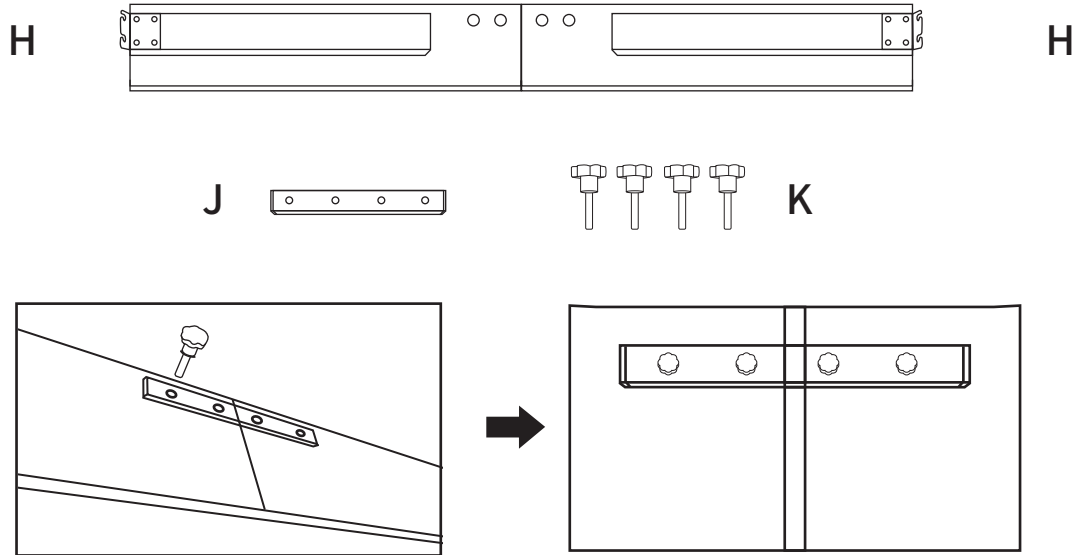

STEP 5: Place the connecting rod on the front baffle and align the four short screws with the screw holes

## Put on the outer sleeves

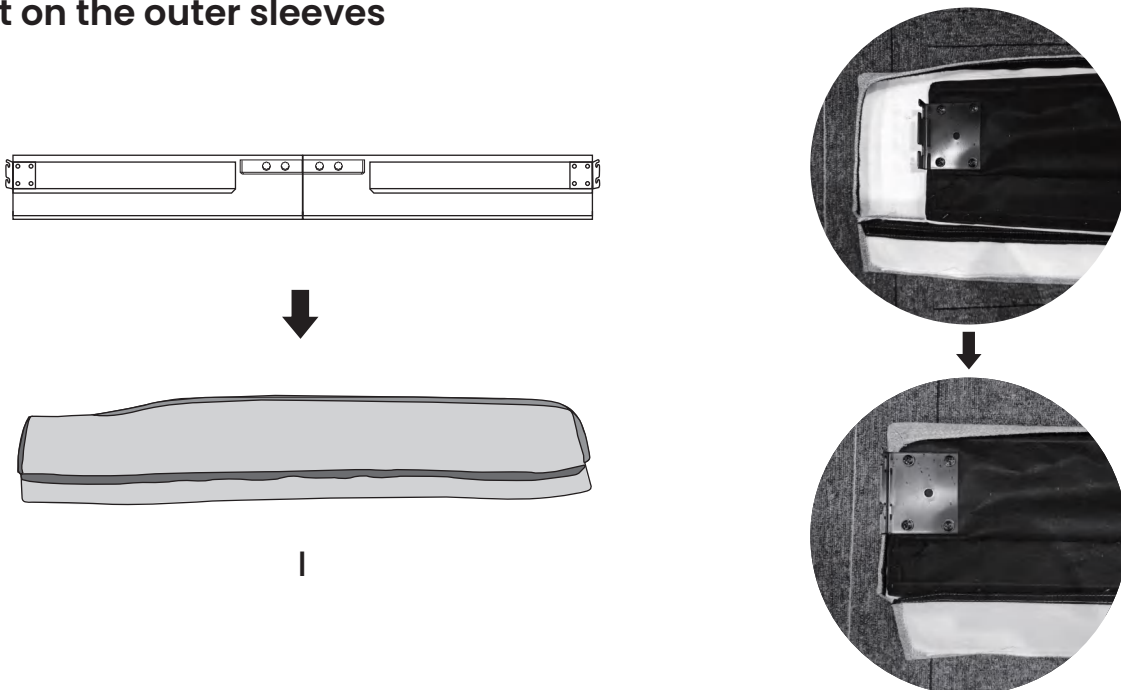

STEP 6: Stuff the Front panel into the cover.

# Installation Procedure

Specific operations are shown in the following figure

## 2 arms connect with front panel

**! NOTICE:** When assembling, the longer fabric side is facing up, which is designed for use and aesthetic reasons. The longer fabric will fill the gap between the seat frame and the front panel.

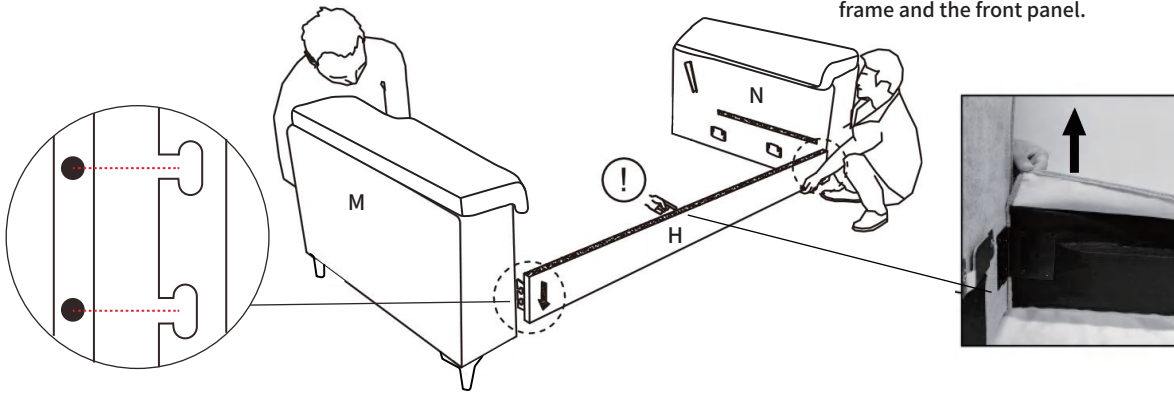

Step 7: To attach the 2 arms with the front panel slide the connectors of the front panel into the armrest's receivers.

## Assemble 2 legs of the seat frame

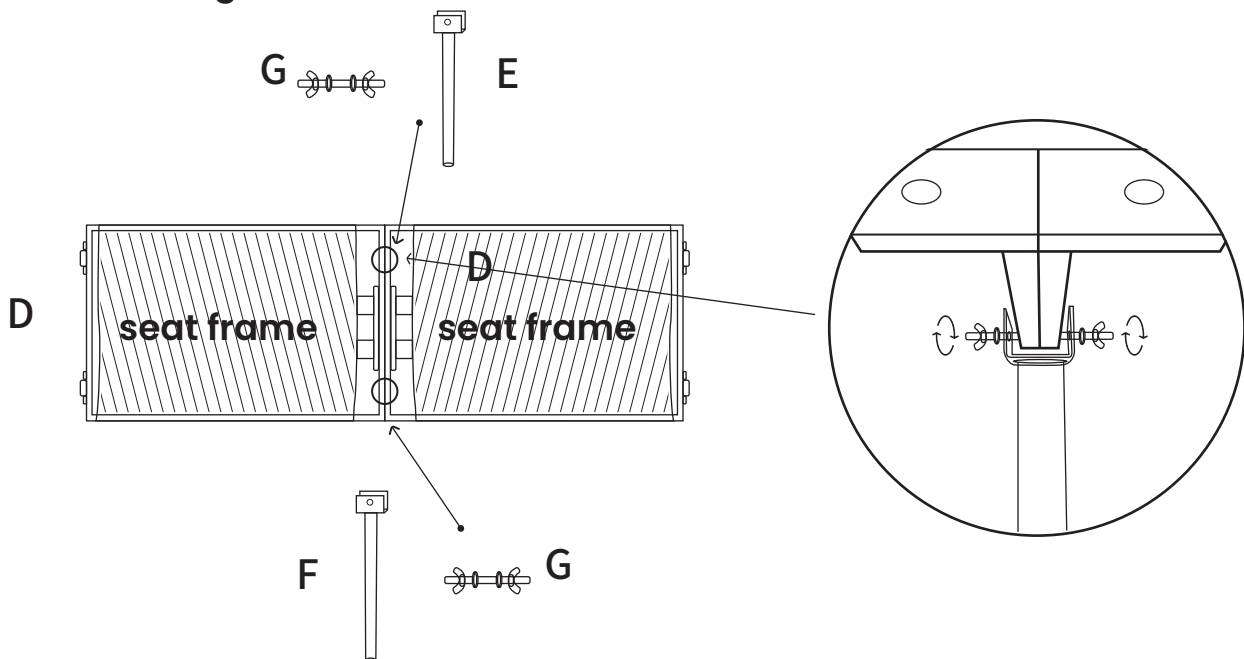

Step 8: Place the support one front and one back in the corresponding position and tighten the screws

# Installation Procedure

Specific operations are shown in the following figure

## Details about the assembling of the legs

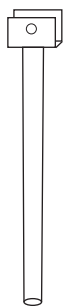
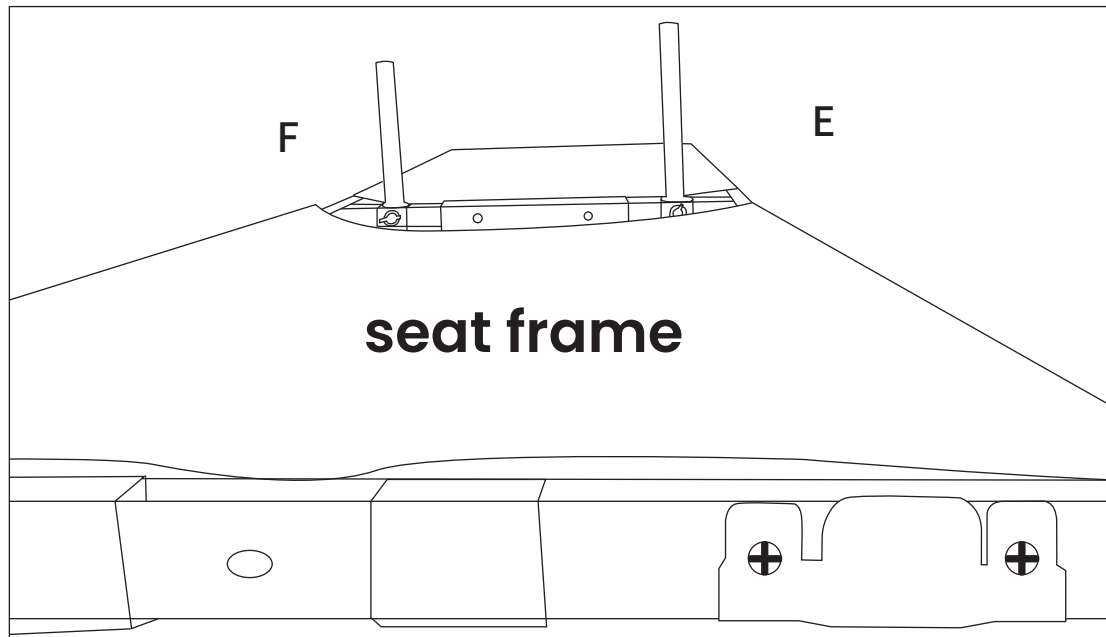

Long support leg(E)

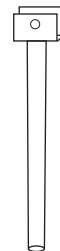

Short support leg(F)



**Attention:** The legs are of different lengths

Step 9: To be more ergonomic ,the legs are of different lengths.

When assembling ,in load-bearing position (sit down /butt position ) you should use the short leg F.

# Installation Procedure

Specific operations are shown in the following figure

## Connect the front panel with the seat frame

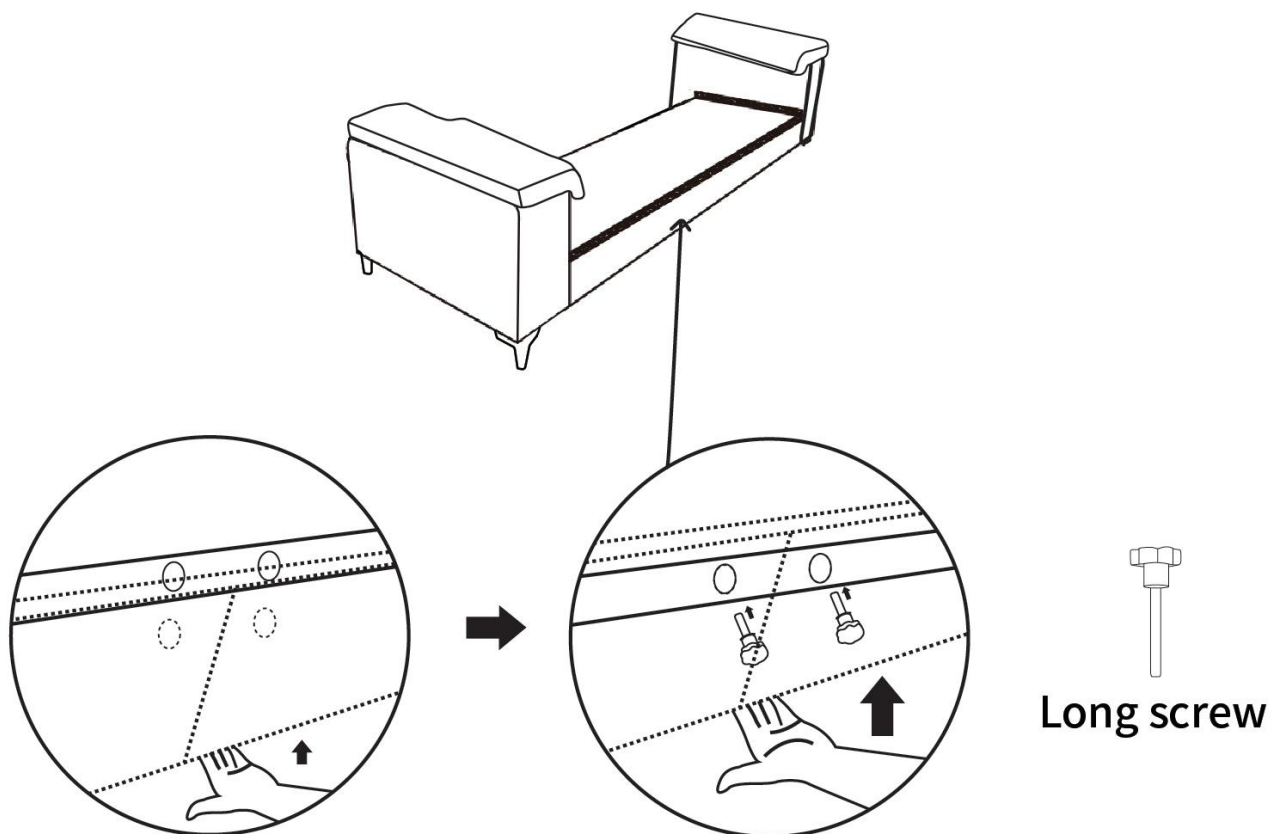

Step 11: Special attention is required in the steps of connecting the front panel with the seat frame. For gravity reasons, the holes in the front panel will not be the same height as the holes in the sofa seat frame. So you need to lift the front panel with your hand, to make sure the 4 holes are in the same height, and then tighten it with screws.

# Installation Procedure

Specific operations are shown in the following figure

**Connect the seat frame with the armrest**

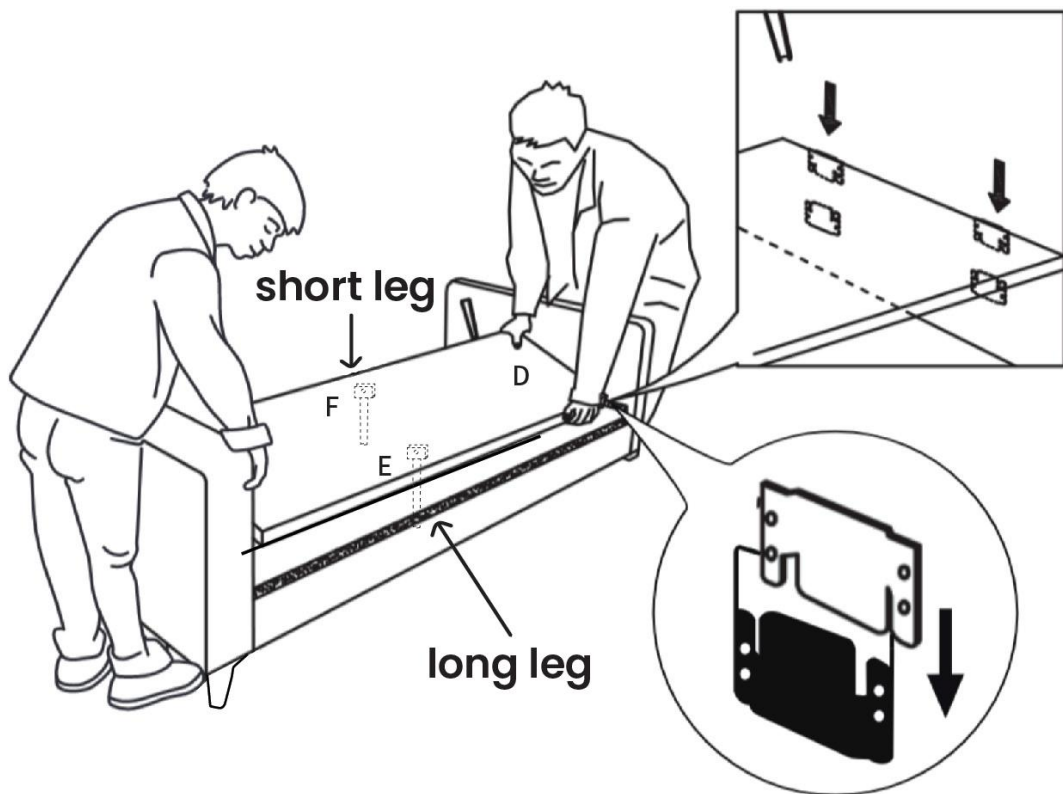

Step 10: To attach the seat base, connect seat's connectors into the arms' receivers. (align, push down to slide into place)

# Installation Procedure

Specific operations are shown in the following figure

## Assemble the backrest

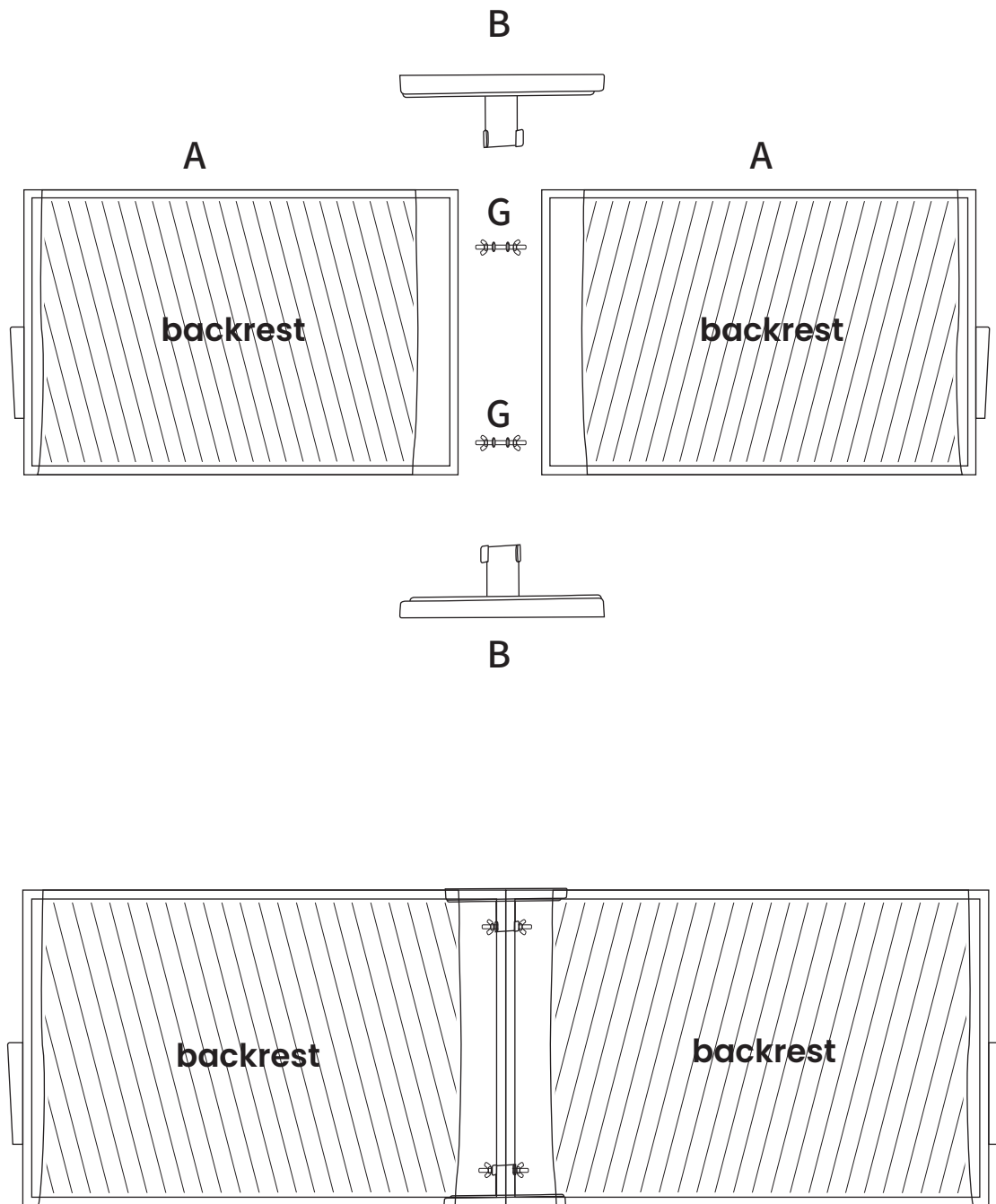

Step 12: When B fastener is connected to A, push the fabric aside. After it is completely stuck, restore it to the original shape and tighten the screws

# Installation Procedure

Specific operations are shown in the following figure

## Connect the backrest with the armrest

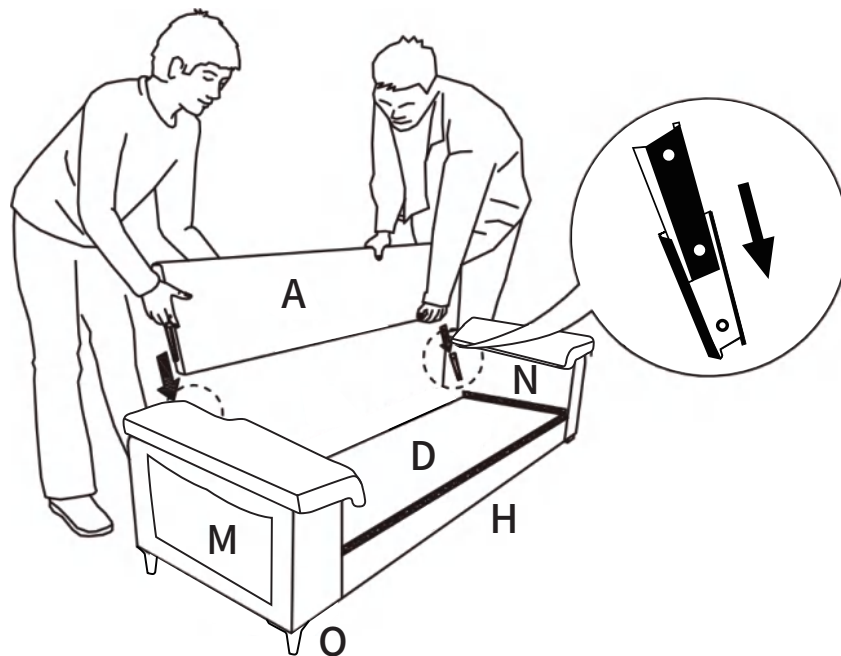

Step 13: To attach the backrest, slide the connectors of the backrest into the arm receivers.  
Note: Team work, angle, align and push down slowly.

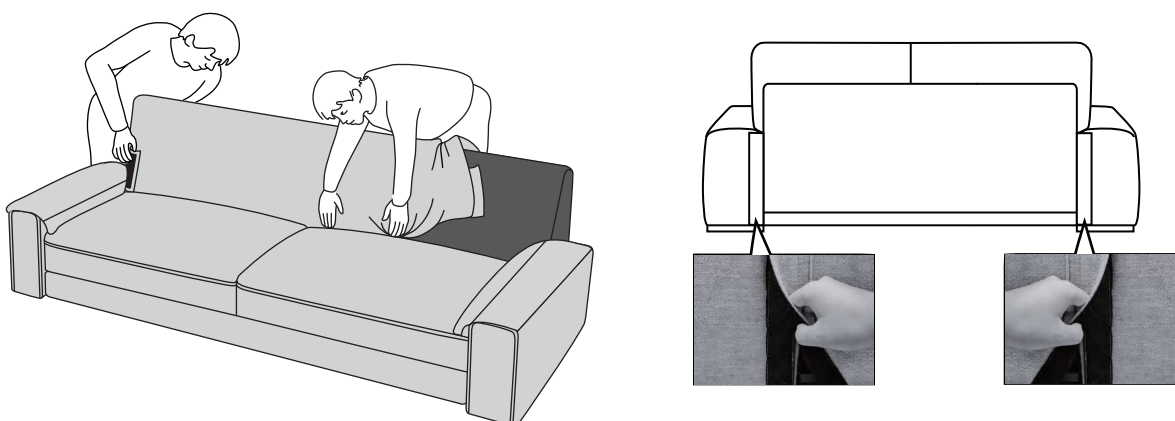

Step 14: Put the cover onto the backrest. Paste the velcro of backrest onto the arms and the bottom

# Installation Procedure

Specific operations are shown in the following figure

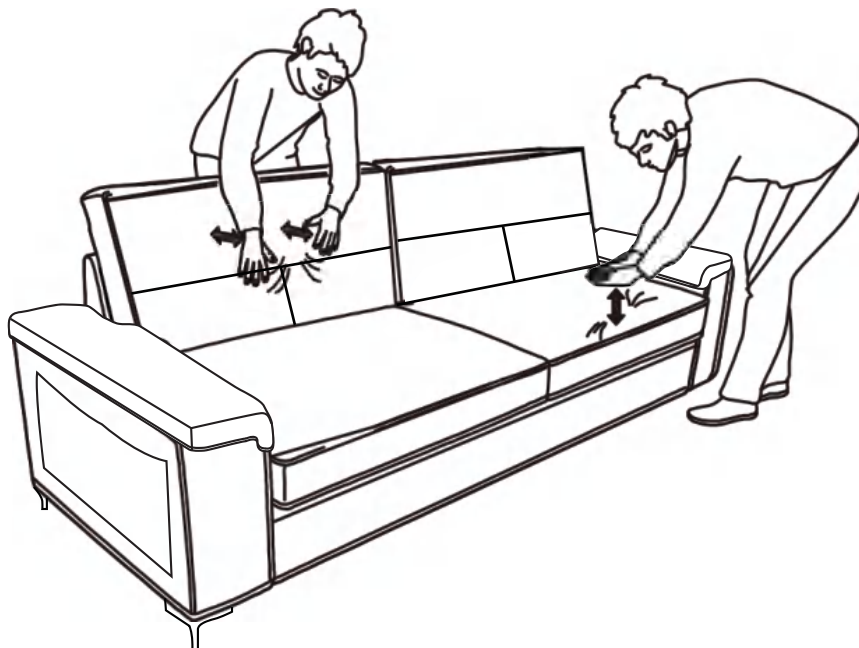

Step 15: Place the cushions and pat it to smooth out the wrinkle.

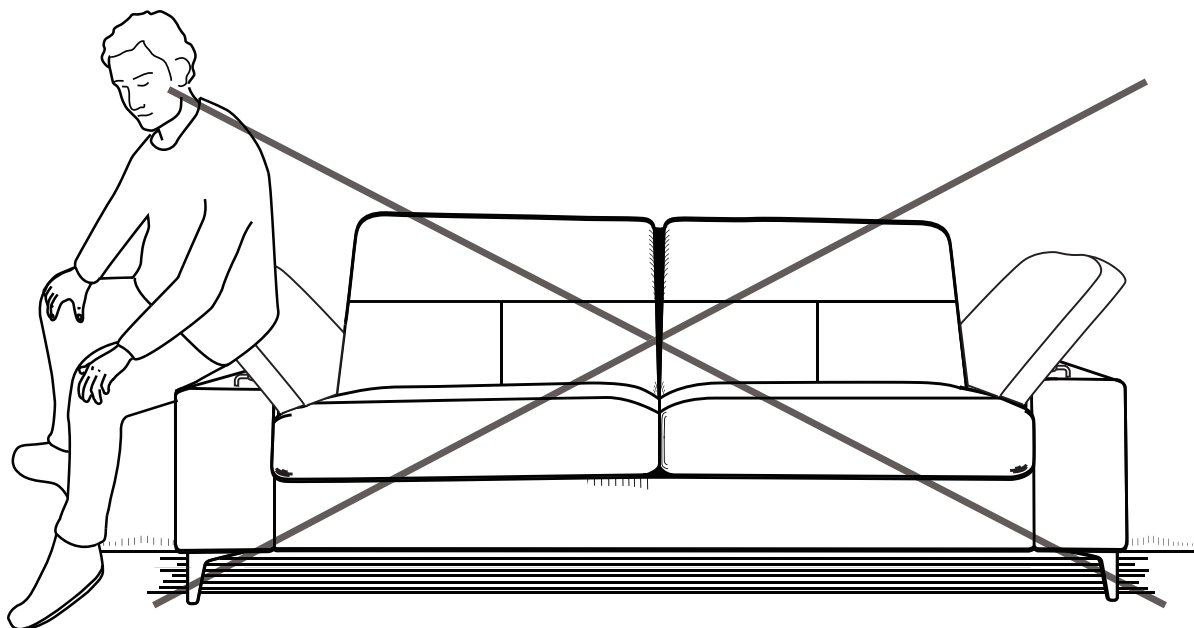

# Installation Procedure

Specific operations are shown in the following figure

3-gear adjustment

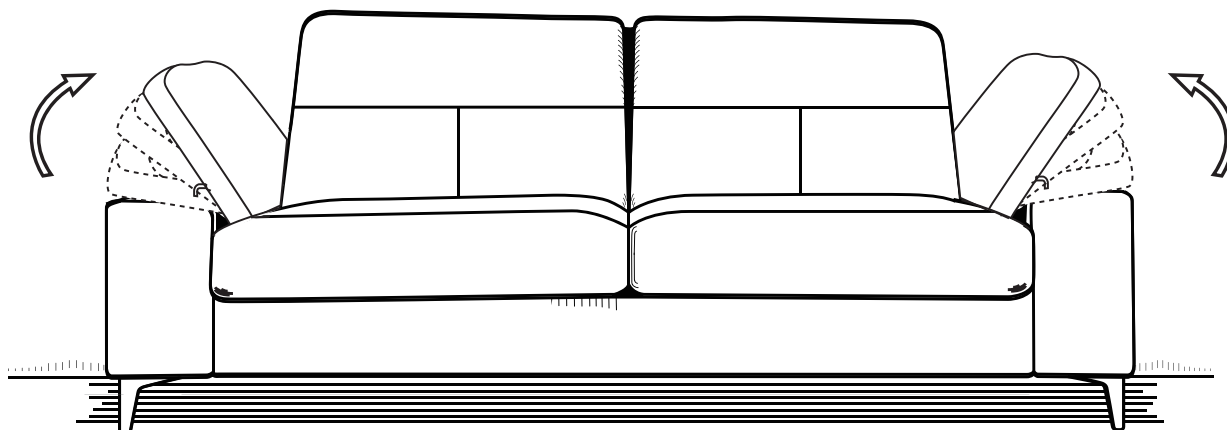

Should you have any questions,  
don't hesitate to reach out to us!

## After-Sales Service Support :

Toll Free Hot Line: (+1) 877-716-5001

Monday-Friday (9:00am-6:00pm)

Email: [service@energyfic.com](mailto:service@energyfic.com)



Scan the QR code and register to extend the  
warranty to 2 years!

