

# Bench Assembly Instructions

(A) Lay the bench on a flat surface with the folded legs facing up. Loosen all nuts using the allen wrenches included.

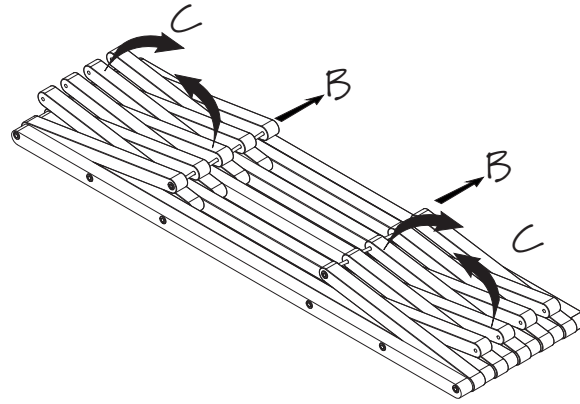

(B) Loosen and remove a threaded rod inserted at the bottom of the leg for shipping (one in each leg)

(C) Open the legs one at a time to create a V, align the holes and insert the threaded rod into the leg holes.

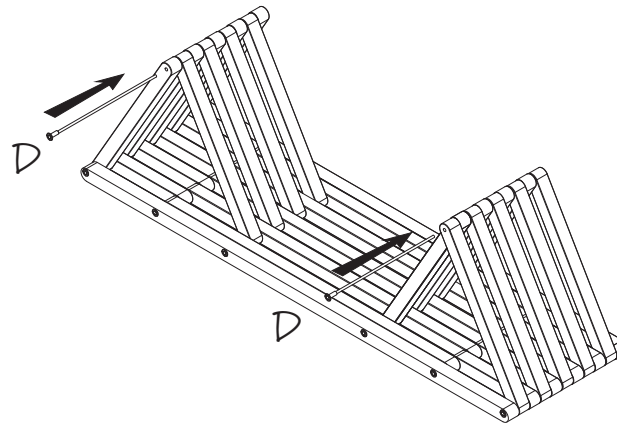

(D) When all legs are up add the nuts (Note: check for the rod centered in the hole before inserting nut)

Repeat the process for the opposite end.

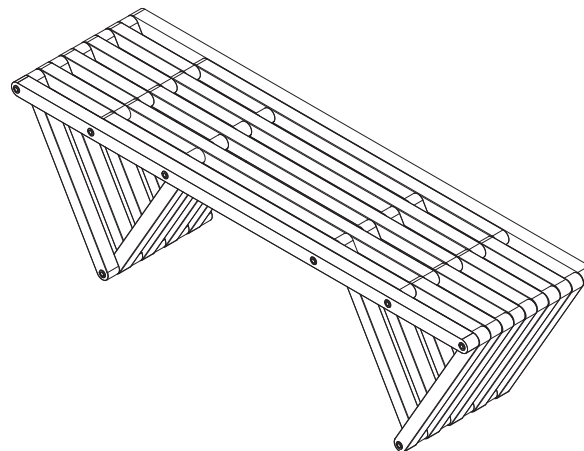

Rotate bench with the top facing up and tighten all nuts.

*Ready!*