

Assembly Instructions

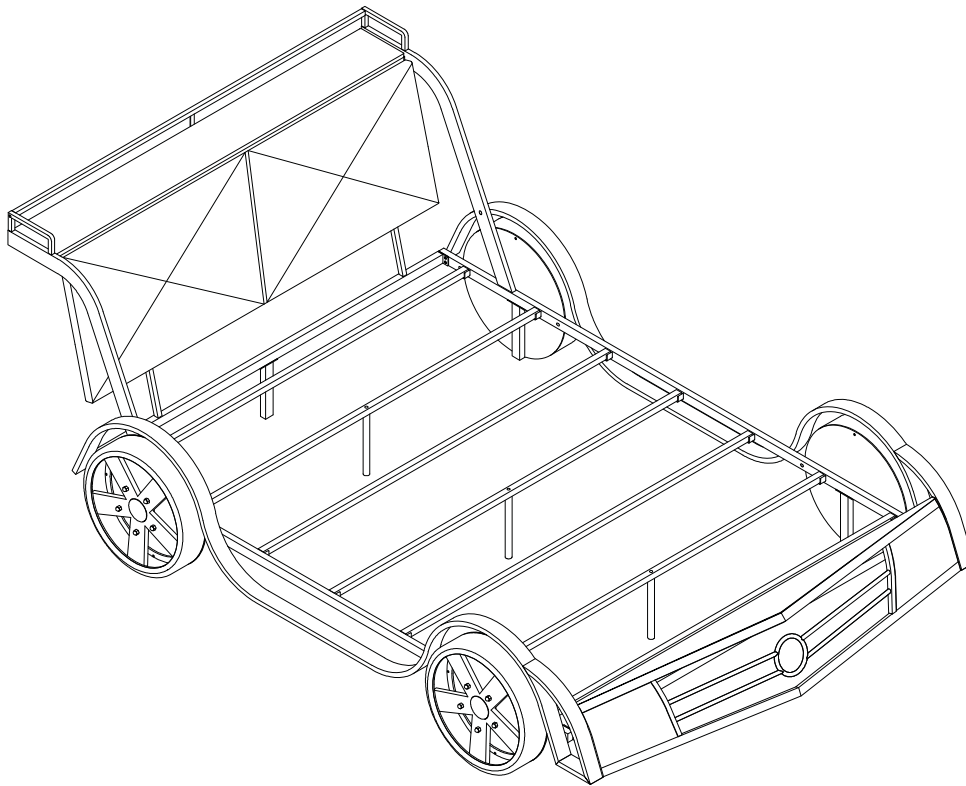

ASSEMBLY RATING

The Assembly Rating is a 5-point system that shows the degree of effort needed in assembling a specific product (with 1 being easy and 5 being difficult). For some products, two persons are recommended.

EASY



DIFFICULT

Tools Required For Assembly:

Allen Wrench

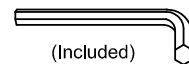

(Included)

Phillips Screwdriver



(Not Included)



2 PERSONS RECOMMENDED

ASSEMBLY & CARE ADVICE

FOR YOUR FURNITURE TO LAST, CORRECT ASSEMBLY AND PROPER MAINTENANCE ARE NECESSARY. PLEASE FOLLOW THE INFORMATION PROVIDED BELOW TO FULLY ENJOY YOUR FURNITURE.

BASIC ASSEMBLY TECHNIQUES

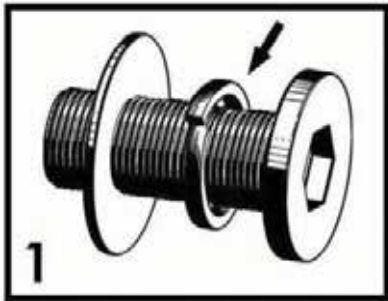

When lock or spring washer is used in an assembly, please make sure the lock or spring washer is placed between the larger flat washer and the head of the screw or bolt.



Position each part correctly and insert screws or bolts into their respective holes by hand tighten or using the proper hand tool. Only tighten when step is completed or when instructed to do so.



Use cardboard or carpet area when assembling furniture to prevent scratches. Make sure the furniture rests on a flat and level surface with each leg evenly touching the floor.

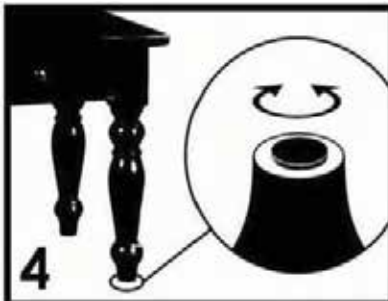

Some furniture comes with height adjustment knobs underneath each leg. To lower or to raise each leg, you need to turn clockwise or counterclockwise, respectively.

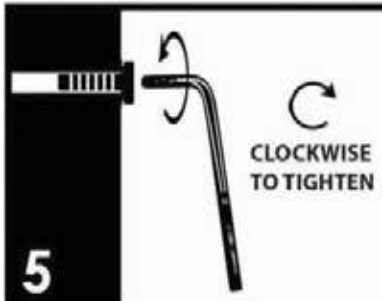

Make sure all parts are properly aligned, then use the appropriate hand tool to completely tighten the bolts or screws. Do not use power tools and do not overtighten.

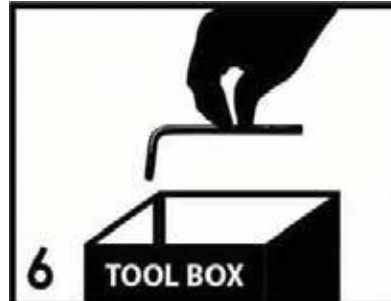

Save the instructions and store the Allen wrench or any supplied tool for later maintenance. After two weeks, check and tighten any loose hardware and repeat again every six months thereafter.

IT IS THE USER'S RESPONSIBILITY TO MAINTAIN THE FURNITURE. THE HARDWARE MAY LOOSEN OVER TIME AND MAY CAUSE THE FURNITURE TO BE WOBBLY AND UNABLE TO SUPPORT ITS INTENDED WEIGHT CAPACITY. THIS MAY LEAD TO COLLAPSE AND MAY CAUSE SERIOUS INJURY.

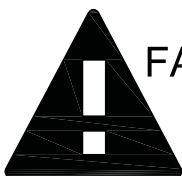

FAILURE TO FOLLOW THE GUIDELINES ABOVE MAY RESULT IN INJURY AND/OR PROPERTY DAMAGE.



Before you begin, please read Page 2 of "Assembly and Care Advice".

And remember, do not tighten until each step is completed or instructed.

Parts List



#1 x 1pc
Left Side Rail



#2 x 1pc
Right Side Rail

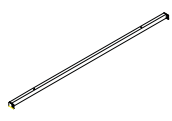

#3 x 1pc
Headboard connect

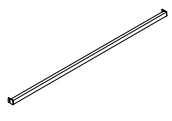

#4 x 1pc
Footboard connect

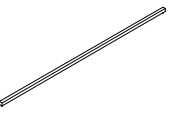

#5 x 4pcs
Slat A

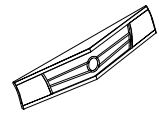

#6 x 1pc
Footboard



#7 x 1pc
Headboard Support A



#8 x 1pc
Headboard Support B

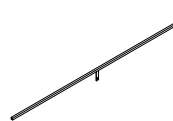

#9 x 1pc
Headboard Up connect

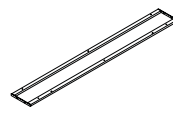

#10 x 1pc
Headboard Up Tube Frame



#11 x 1pc
Headboard Frame

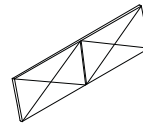

#12 x 1pc
Headboard Panel

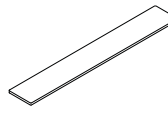

#13 x 1pc
Shelf



#14 x 5pcs
Rail Support Leg



#15 x 4pcs
Wheel

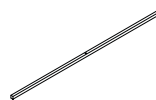

#16 x 3pcs
Slat B



Before you begin, please read Page 2 of "Assembly and Care Advice".

And remember, do not tighten until each step is completed or instructed.



#17 x 3pcs
Slat Support Leg

Hardware List



#A x 4pcs
Bolt 1/4"X1-3/4"



#B x 11pcs
Bolt 1/4"X1-3/8"



#C x 10pcs
Bolt 1/4"X1"



#D x 31pcs
Bolt 1/4"X1/2"



#E x 2pcs
Bolt 1/4"X1-1/4"



#F x 1pc
Allen Wrench M4



#G x 6pcs
Screw M4 X 25



#H x 6pcs
Flat Washer Ø12xØ5x0.8



#I x 6pcs
Flat Washer Ø16xØ7x1.0



1. Place the left/right side rails (#1,2) onto a protected surface, then align the headboard support (#7,8) as displayed and insert a bolt (#C). Secure using the Allen wrench.

#A x 2pcs
#C x 2pcs
#D x 6pcs

2. Align the rail support legs (#14) to the end of the side rails (#1,2) with the headboard supports (#7,8). Then insert a bolt (#A) and a bolt (#D). Secure using the Allen wrench.

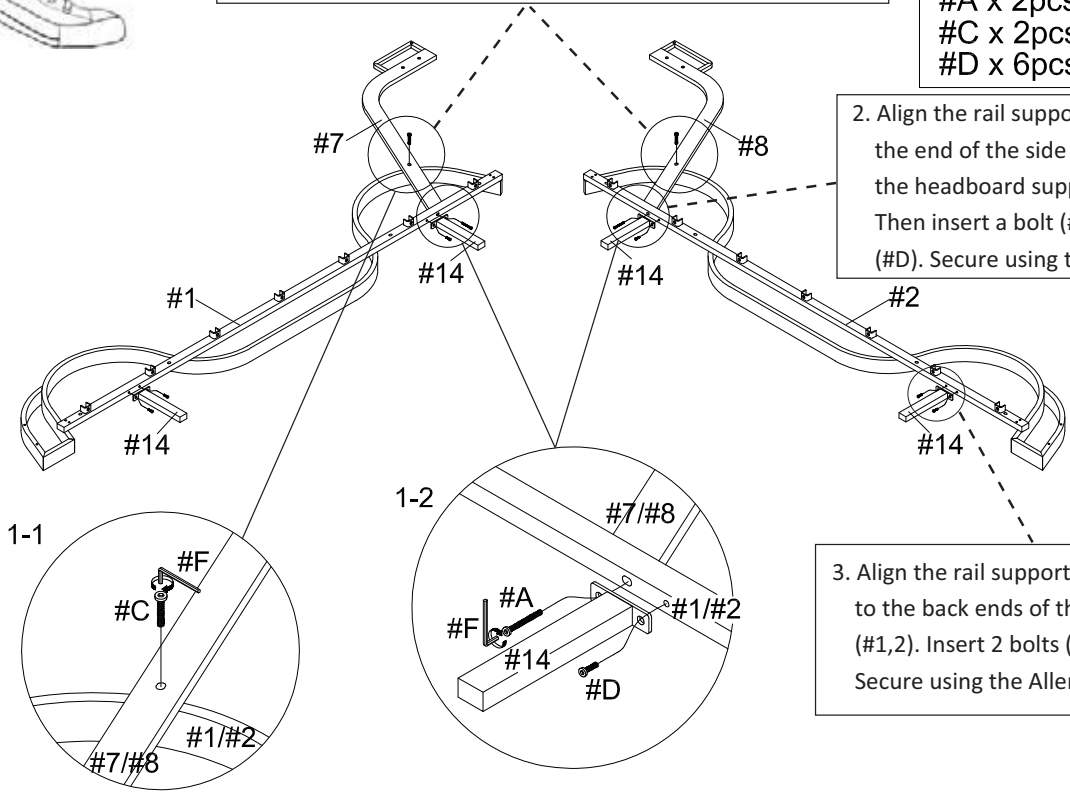

3. Align the rail support legs (#14) to the back ends of the side rail (#1,2). Insert 2 bolts (#D) into each. Secure using the Allen wrench (#F).



2. Align each end of the the headboard connect (#3) to the holes along the ends of the left/right side rails (#1,2). Insert 2 bolts (#D) into each end and secure using the Allen wrench (#F).

#D x 10pcs

3. Align each end of the the footboard connect (#4) to the holes along the ends of the left/right side rails (#1,2). Insert 2 bolts (#D) into each end. Secure using the Allen wrench (#F).

1. Align a rail support leg (#14) to the hole along the center of the headboard connect (#3). Insert 2 bolts (#D) into the leg. Secure using the Allen wrench (#F).

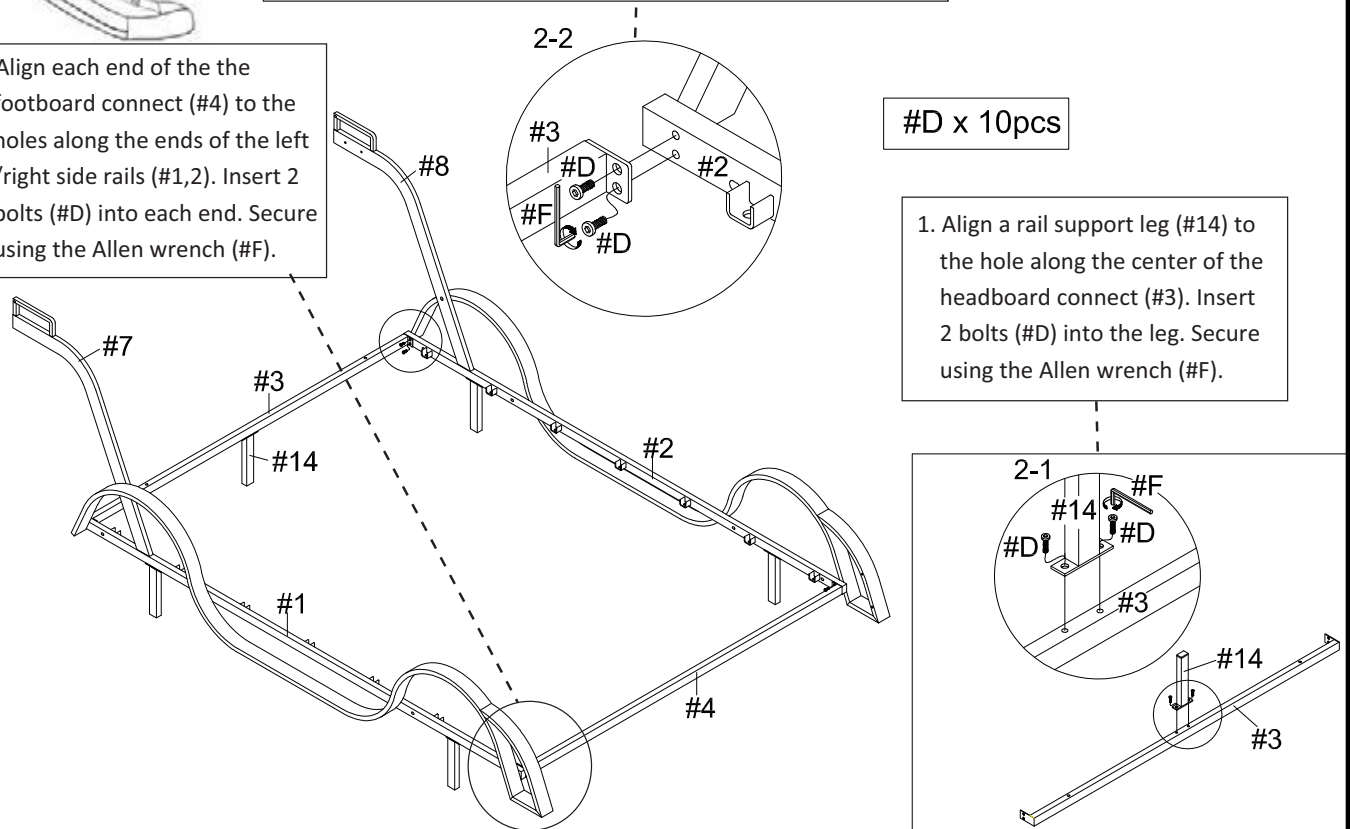



1. Align the headboard up tube frame (#10) to the top of the headboard supports (#7,8) then insert 2 bolts (#D) into each end. Align the headboard up connect (#9) and insert a bolt (#C) into each end. Secure using the Allen wrench (#F).

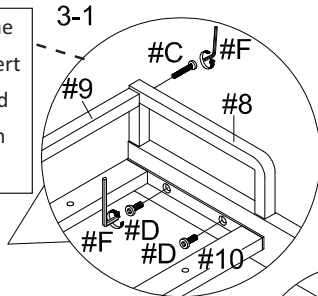

4. Apply a flat washer (#1) onto the bolt (#D), then place the slats (#16). Insert bolts from below and secure using the Allen wrench.

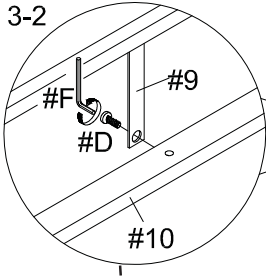

2. Align the bracket along the headboard up connect (#9) to the headboard up tube frame (#10). Insert a bolt (#D) and secure using the Allen wrench (#F).

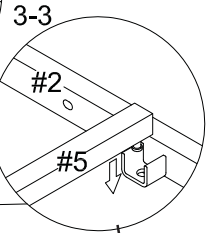
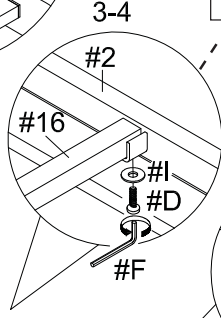

3. Place the slats (#5) onto every other slot along the side rails.

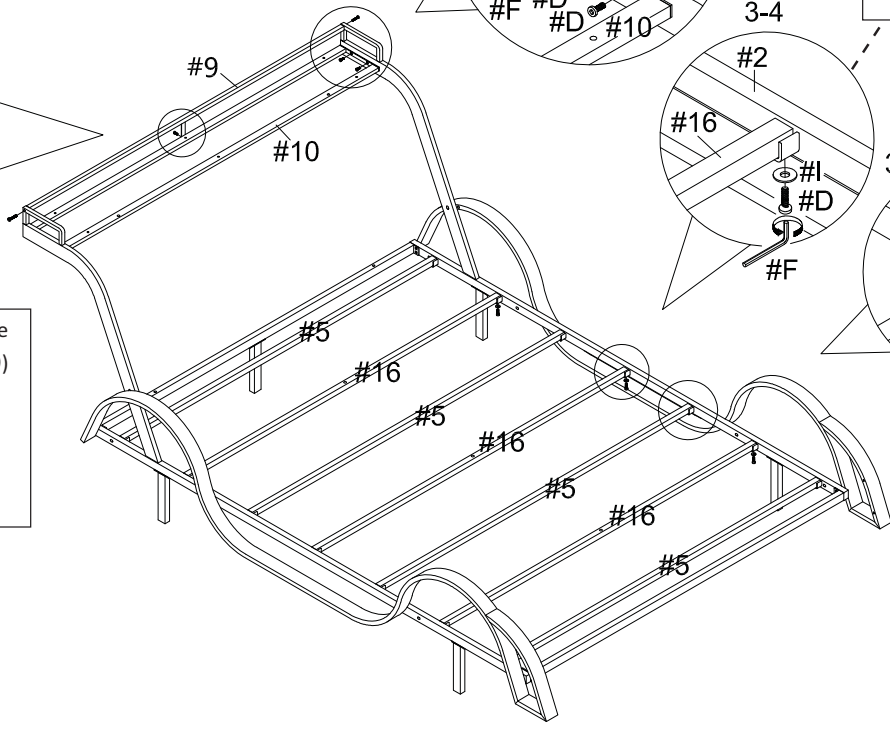

#C x 2pcs
#D x 11pcs
#I x 6pcs



#A x 2pcs
#E x 2pcs

4-1

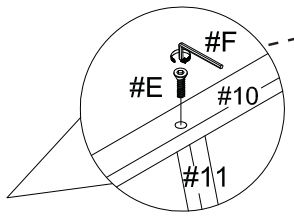

1. Align the headboard frame (#11) to the holes as displayed, then insert a bolt (#E) into each top end. Secure using the Allen wrench (#F).

4-2

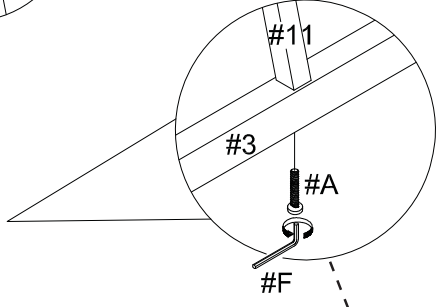

2. Insert a bolt (#A) into each bottom end. Secure using the Allen wrench (#F).

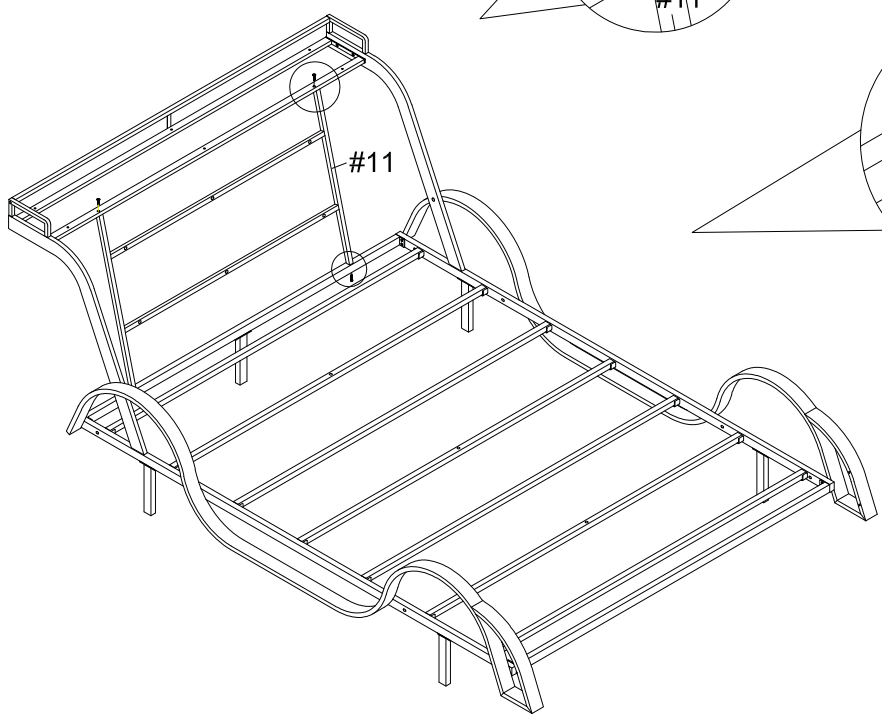



1. Prepare 6 screws by inserting a flat washer (#H) onto the screws (#G). Place the shelf (#13) on top, then insert the screw assemblies. Secure using a screwdriver.

#C x 6pcs
#G x 6pcs
#H x 6pcs

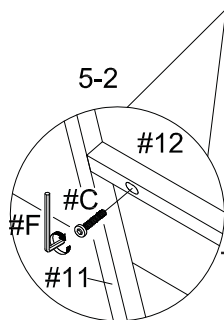
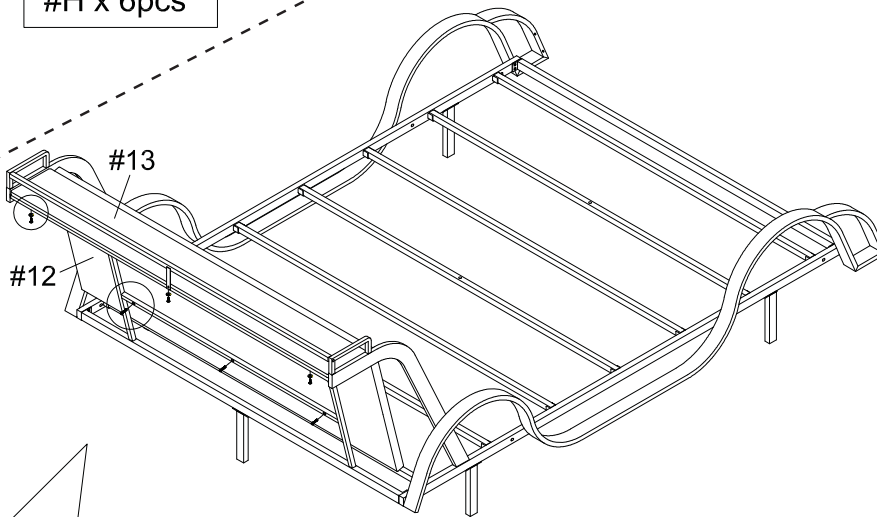
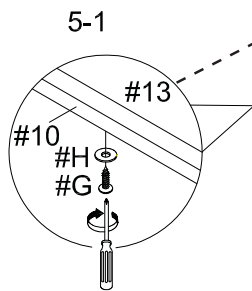

2. Place the headboard panel (#12), then insert a bolt (#C) into each hole from the back. Secure using the Allen wrench (#F).



#D x 4pcs

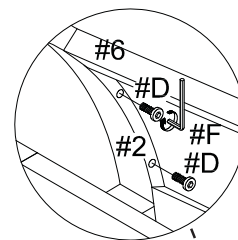
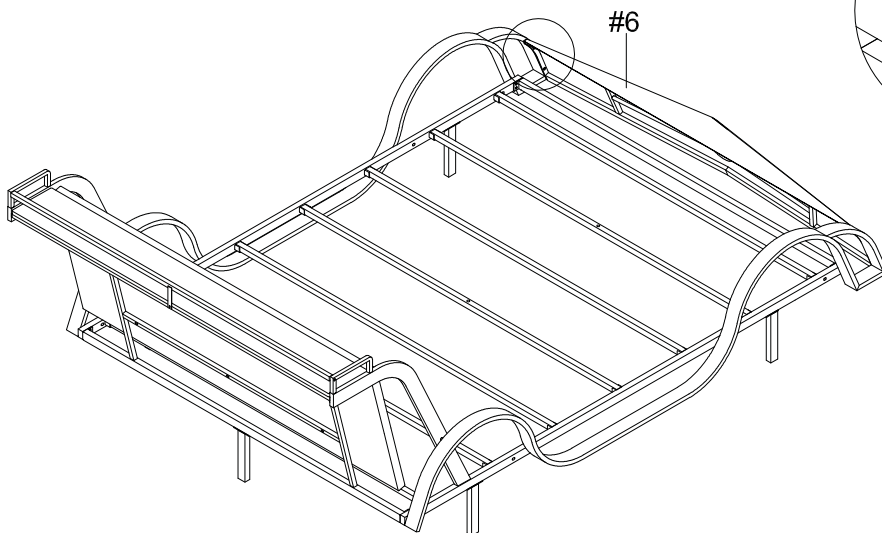

Align the footboard (#6) to the front, then insert 2 bolts (#D) into each end. Secure using the Allen wrench (#F).



1. Align the wheels (#15) to the holes along the sides of the side rails. Insert 2 bolts (#B) into each. Secure using the Allen wrench (#F).

#B x 11pcs

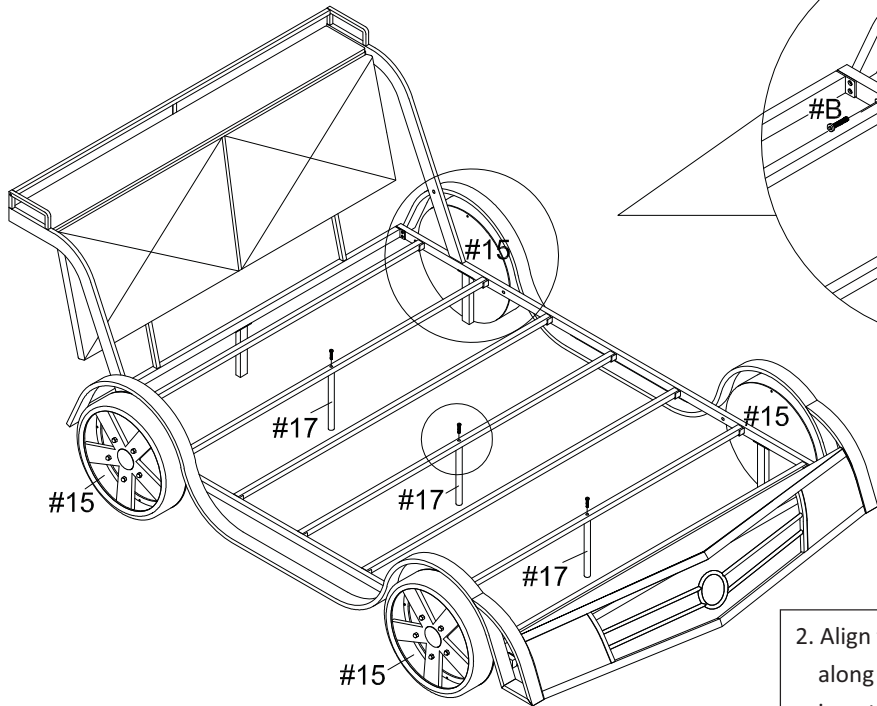

7-1

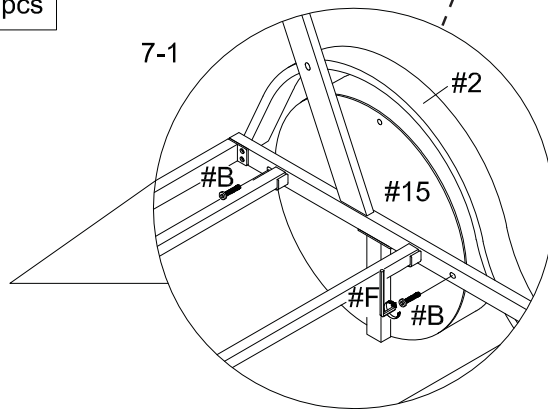

7-2

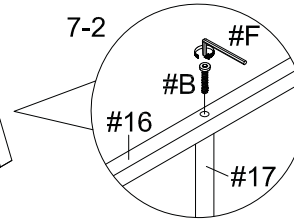

2. Align the slat support legs (#17) to the holes along the center of the slats. From above insert a bolt (#B). Secure using the Allen wrench.

