







ASSEMBLY INSTRUCTION

317-707L/M 44" Round Pedestal Table
 317-708L/M 54" Round Pedestal Table

HARDWARE LIST

A	B	C	D	E	F
					
Bolt	Bolt	Bolt	Lock Washer	Flat Washer	Allen Key
Ø5/16"*1-3/4"	Ø5/16"*2-1/2"	Ø5/16"*1-1/8"	Ø5/16"	Ø5/16"*19D	100*50*4mm
4 PCS	1 PC	6 PCS	11 PCS	11 PCS	1 PC

PART LIST

1	2	3	4
Table Top	Bridge Plate	Upper Half Quad Frame	Lower Half Quad Frame
1 PC	1 PC	1 PC	1 PC

IMPORTANT NOTES

- Place all wooden parts on clean and smooth surface such as rug or carpet to prevent the parts from being scratched.
- Check to be sure that you have all parts and hardware.
- Remove all wrapping materials, including staples and packing straps before you start to assemble.
- Do not tighten all screws and bolts until completely assembled.
- Keep all hardware out of the reach of children

STEP 5

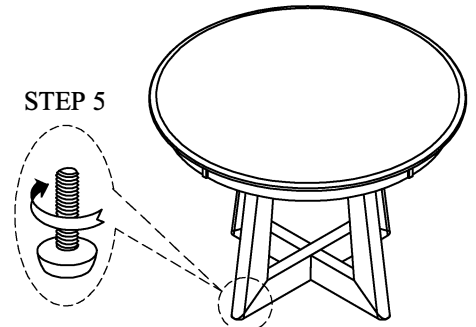

STEP 5. Carefully turn the table up. Adjust the levelers at the bottom of the feet if needed to level table on uneven floor.

STEP 1

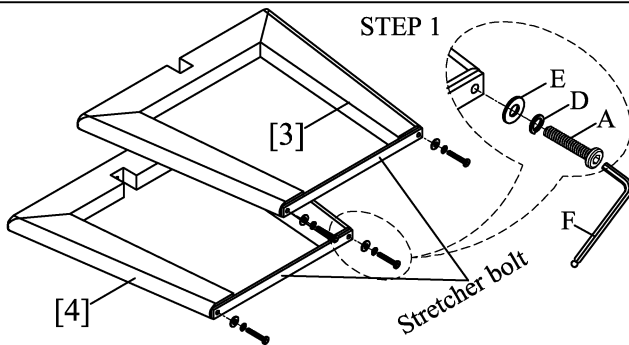

STEP 1. Stretcher bolt is installed for delivery protected purposes. Unbolt bolt (A), lock washer (D) and flat washer (E) by allen key (F) and keep them well for re-use in step 3. Remove the stretcher bolt.

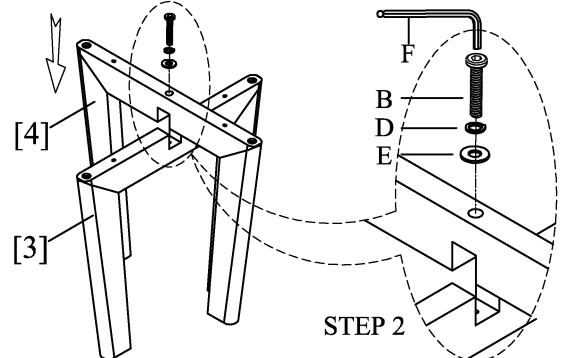

STEP 2. Assemble upper half quad frame (3) and lower half quad frame (4) using bolt (B), lock washer (D), flat washer (E) and tighten them by allen key (F).

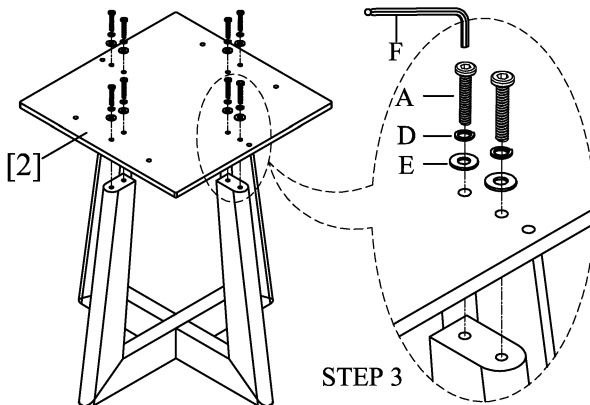

STEP 3. Assemble the bridge plate (2) to the leg by tighten bolts (A), lock washers (D), flat washers (E) from step 1 & hardware list with allen key (F).

STEP 4

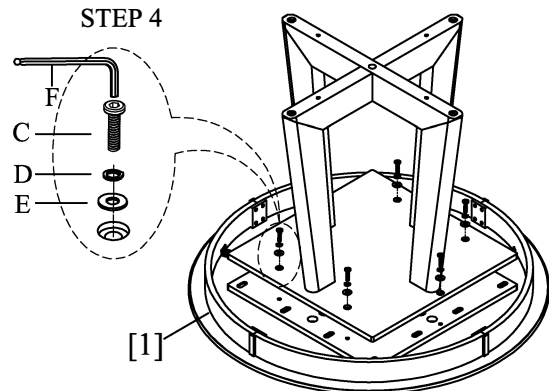

STEP 4. Turn the table top (1) upside down on clean soft surface and attach the leg assembly to the table top (1) as shown in the picture using bolt (C), lock washer (D), flat washer (E) and tighten them by allen key (F)

MADE IN VIETNAM