

INSTRUCTION MANUAL

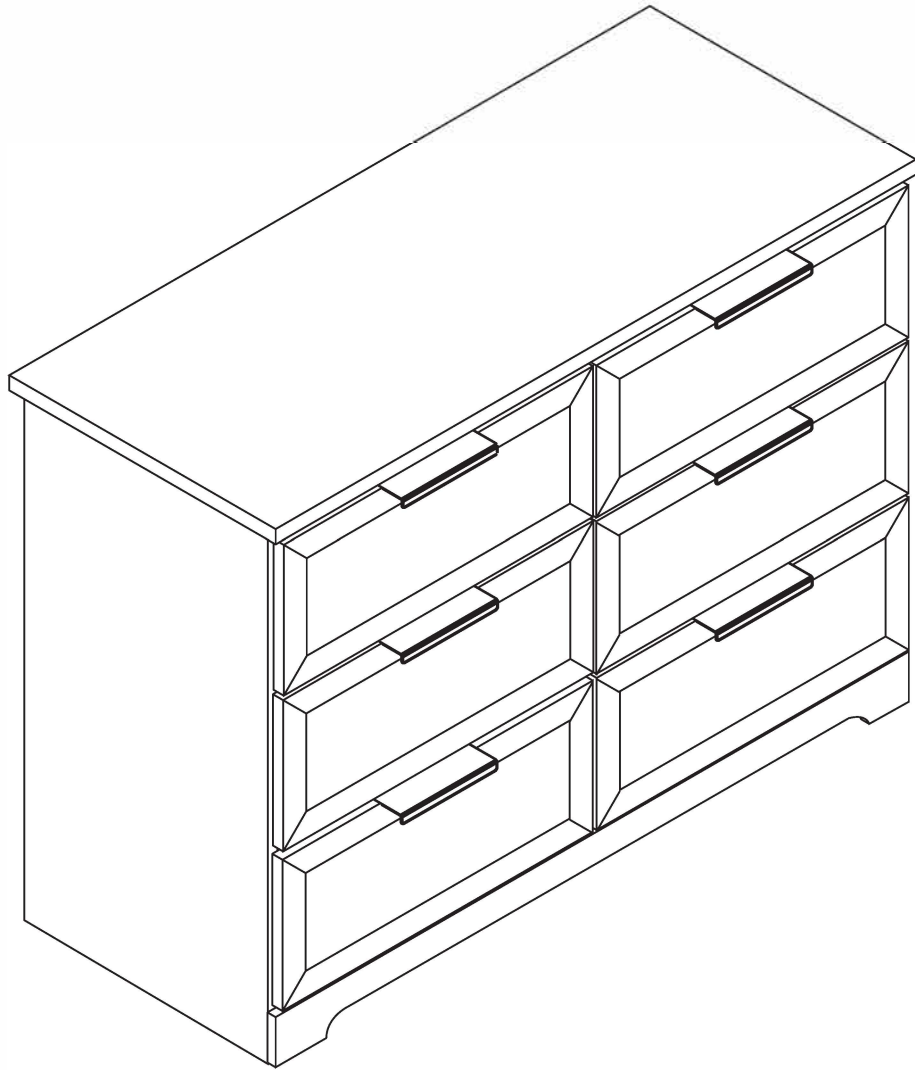

TOOLS REQUIRED



**PHILLIPS
SCREWDRIVER**

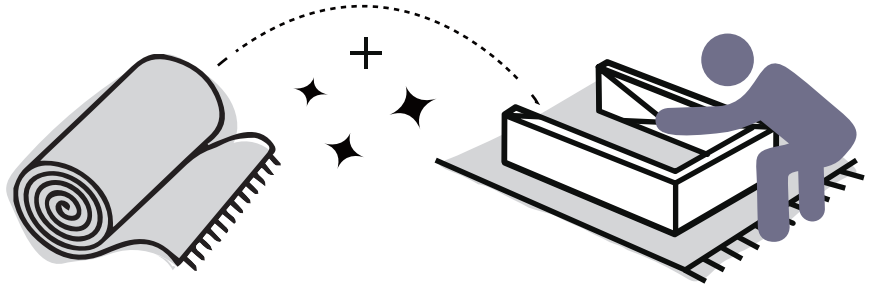

PARTS

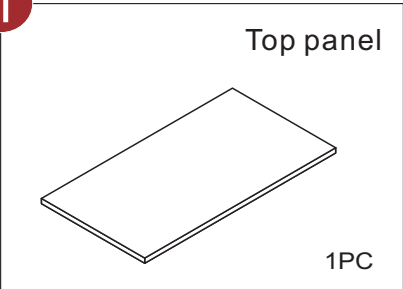
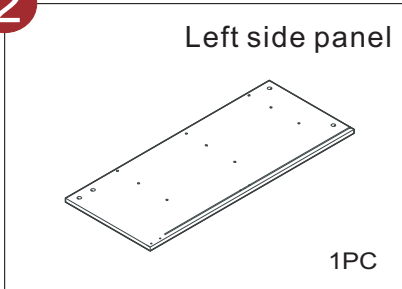
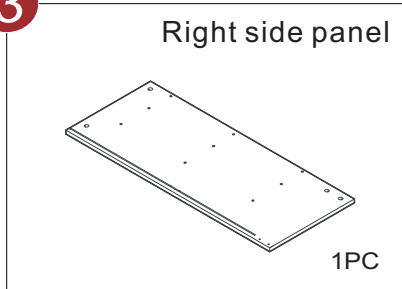
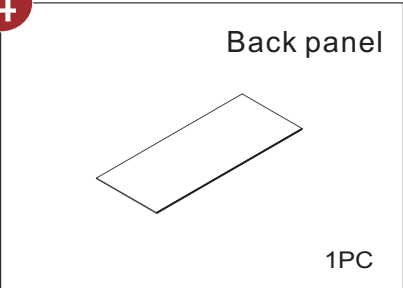
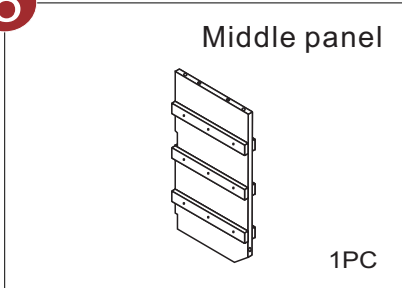
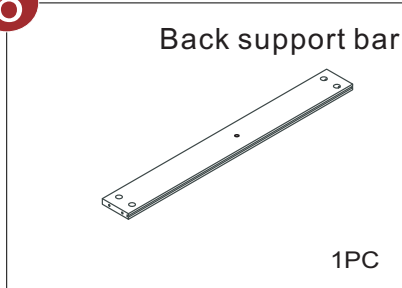
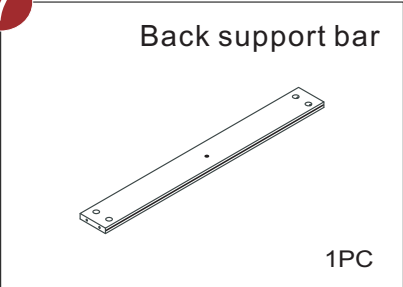
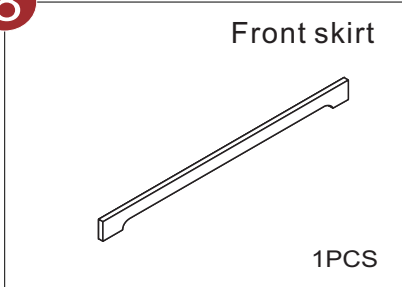
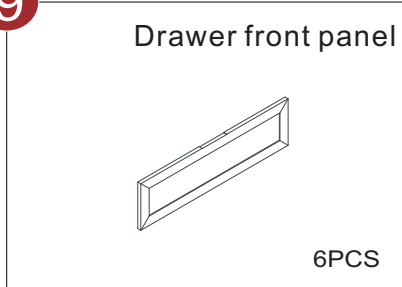
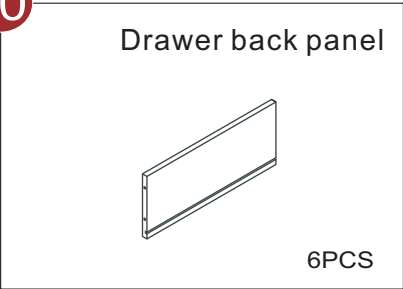
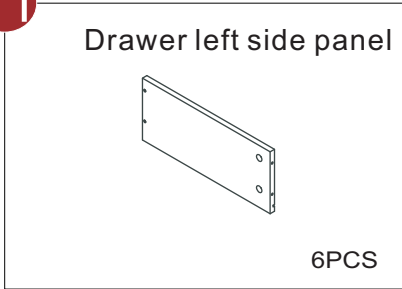
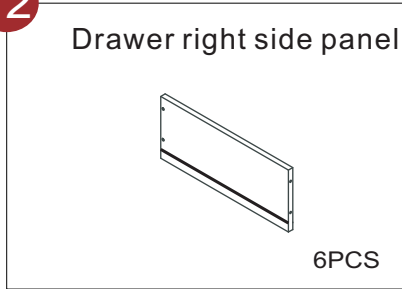
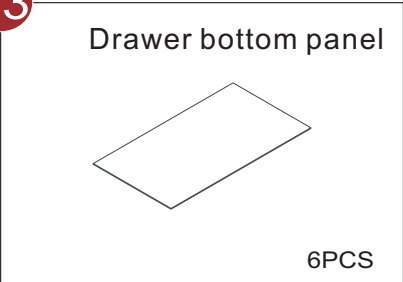
- 1** Top panel

1PC
- 2** Left side panel

1PC
- 3** Right side panel

1PC
- 4** Back panel

1PC
- 5** Middle panel

1PC
- 6** Back support bar

1PC
- 7** Back support bar

1PC
- 8** Front skirt

1PCS
- 9** Drawer front panel

6PCS
- 10** Drawer back panel

6PCS
- 11** Drawer left side panel

6PCS
- 12** Drawer right side panel

6PCS
- 13** Drawer bottom panel

6PCS

HARDWARE

A

Cam bolt



M6X35mm

43PCS

B

Cam lock



43PCS

CL

Drawer slide



6PCS

CR

Drawer slide



6PCS

DL

Drawer slide



6PCS

DR

Drawer slide



6PCS

E

Screw



M3x12mm

84PCS

F

Screw



M4X35mm

28PCS

G

Wooden dowel

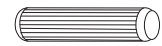

M6X30mm

6PCS

H

Screw



M3x14mm

8PCS

I

Corner brace

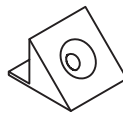

8PCS

J

Handle



6PCS

K

Anti-tip kit

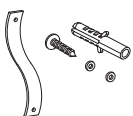

2PCS

! NOTICE

Please retain these instructions for future reference.

- Make sure that all screws are tightened. Check these regularly. Do not overtighten the screws!
- Do not use or store this item in the proximity of open flame or flammable/combustible chemicals.
- If any parts are missing, broken, damaged, or worn, stop using this item until repairs are made and/or factory replacement parts are installed.
- When cleaning do not use any abrasive or caustic agents or hard brushes etc.
- Clean the surfaces with a damp, lint-free cloth and wipe with a dry cloth.
- Carefully remove all packing material and discard it sorted. Make sure that you do not accidentally throw away mounting material.
- Any question or problem, please contact us freely!

PRODUCT ASSEMBLY

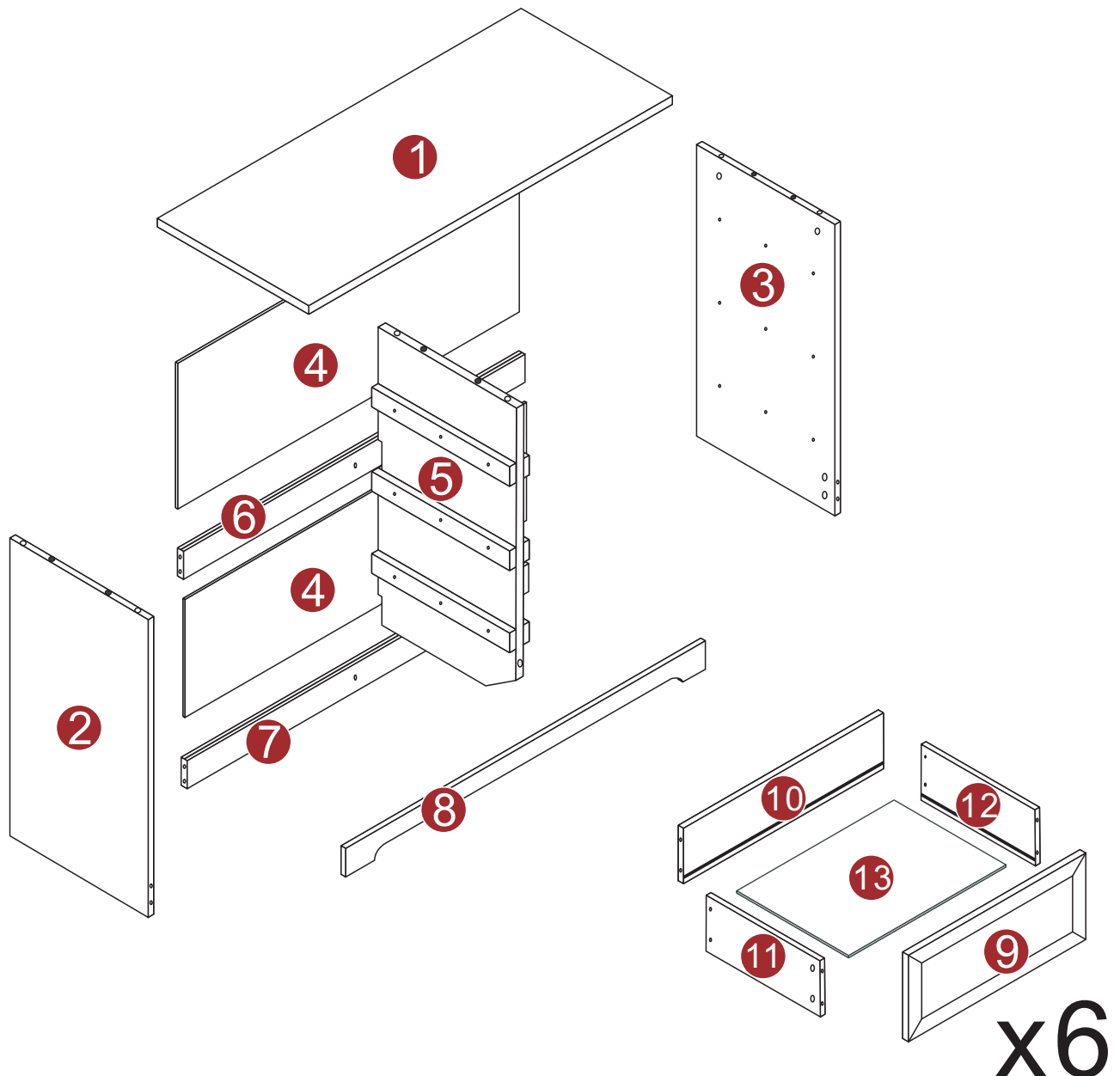

1

Attach four cam bolt A to panel #2.

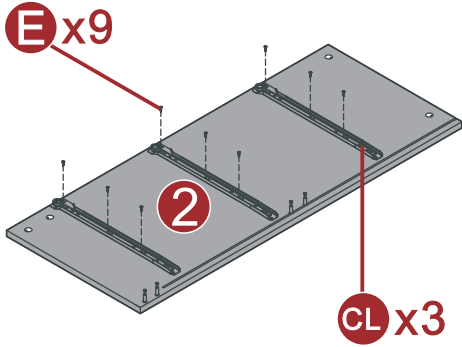
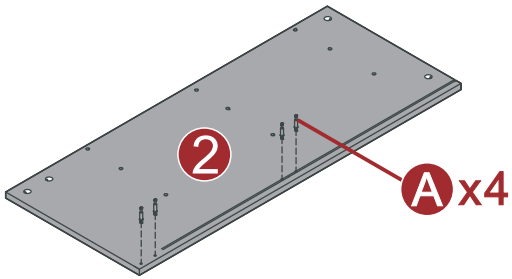

	CL x3
	A x4
	E x9

Attach three drawer slide CL to panel #2 with nice screw E, three screws per slide.

2

Attach four cam bolt A to panel #3.

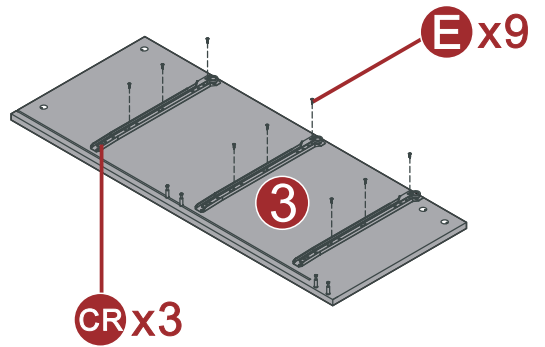
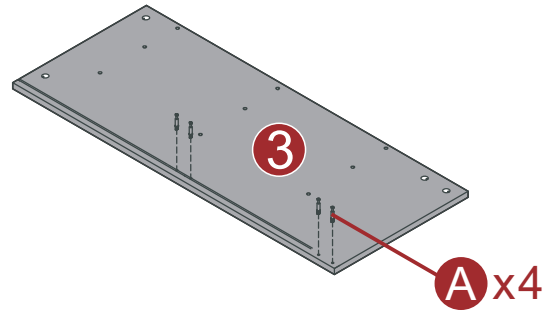

	CR x3
	A x4
	E x9

Attach three drawer slide CR to panel #3 with nice screw E, three screws per slide.

3

Attach three drawer slide CR to panel #5 with nine screw E, three screws per slide.

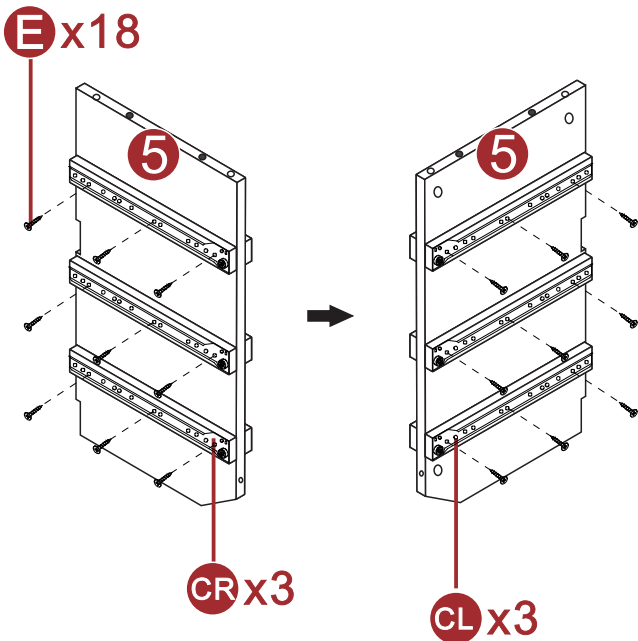

	CR x3
	CL x3
	E x18

Attach three drawer slide CL to panel #5 with nine screw E, three screws per slide.

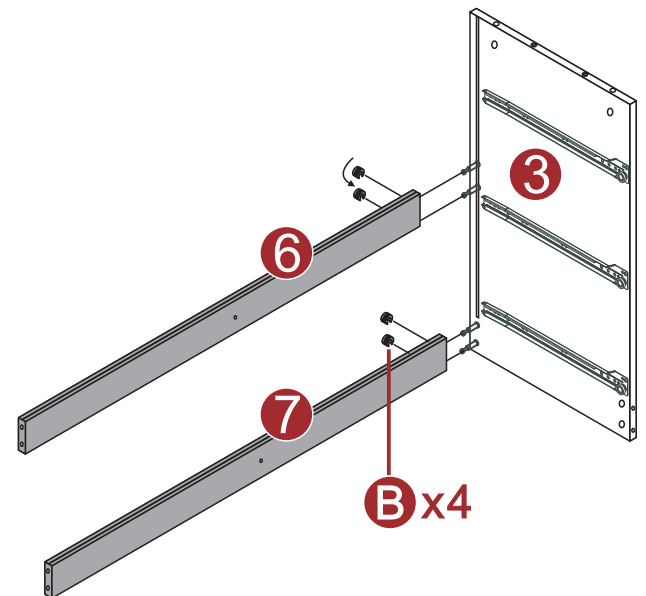
4

Attach panel #6 and #7 to panel #3, secure with four cam lock B, two locks per panel.

	B x4
--	------

5

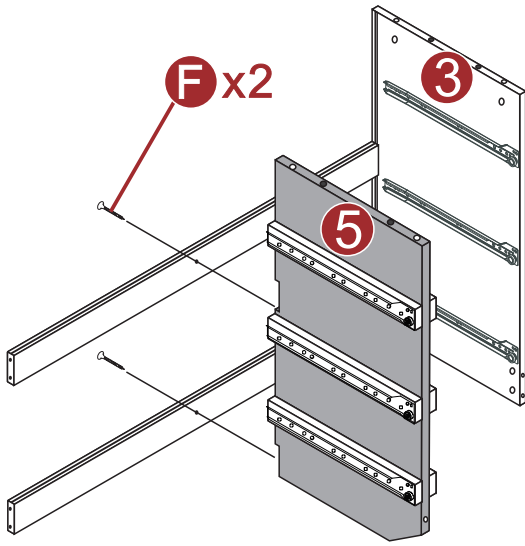

Attach panel #5 to panel #6 and #7 with two screw F.

Fx2

6

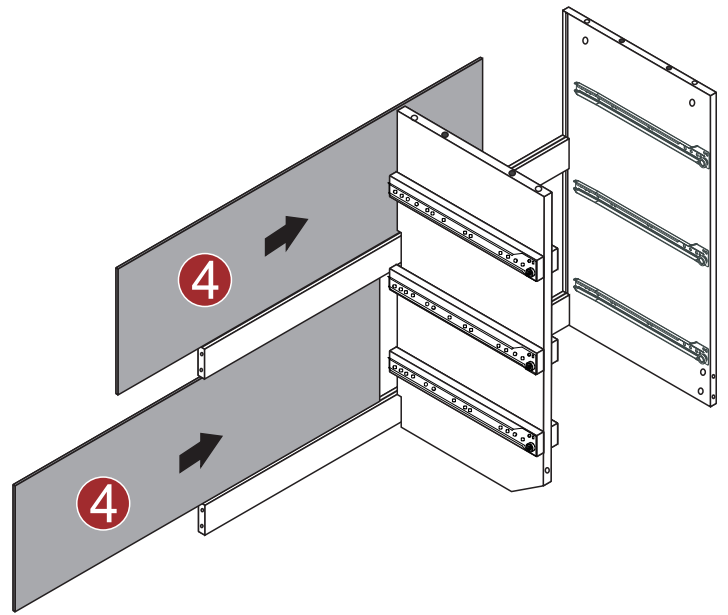

Insert back panel #4 as shown.

7

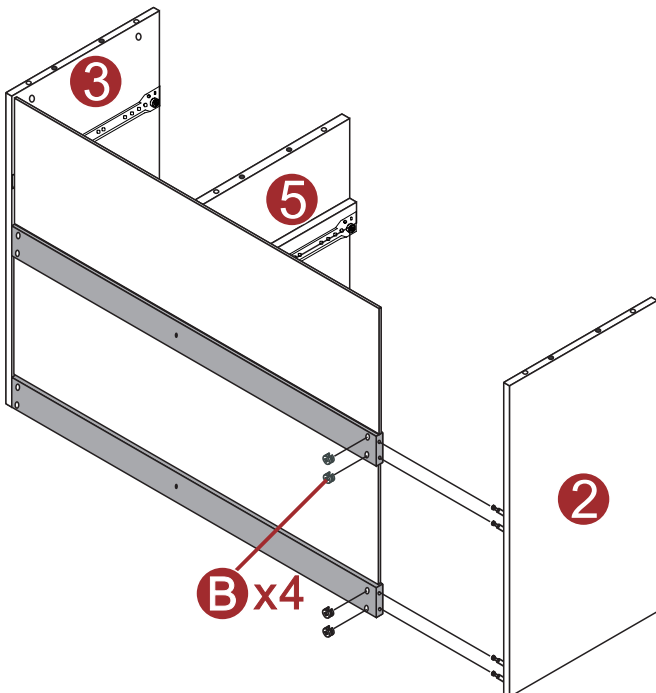

Attach panel #2 to panel #6 and #7, secure with four cam lock B.

Bx4

8

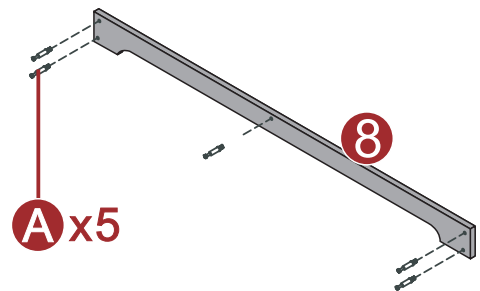

Attach five Cam bolt A to panel #8.

Ax5

9

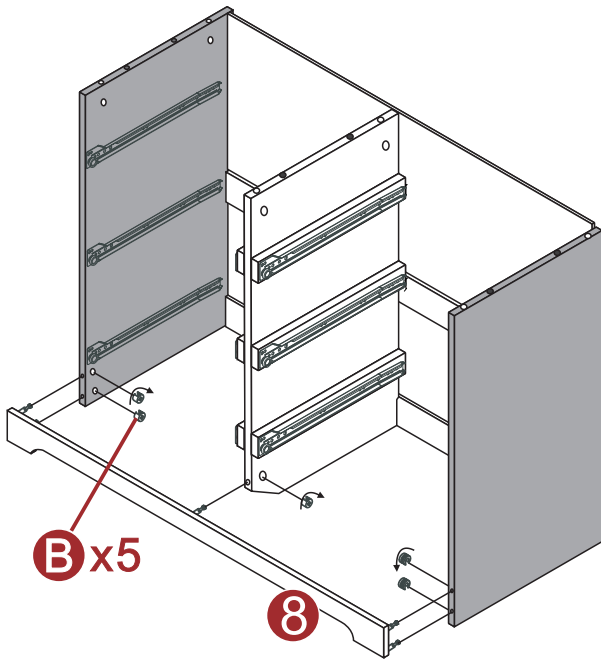

Attach front skirt to the cabinet and secure with five cam lock B.

 Bx5

10

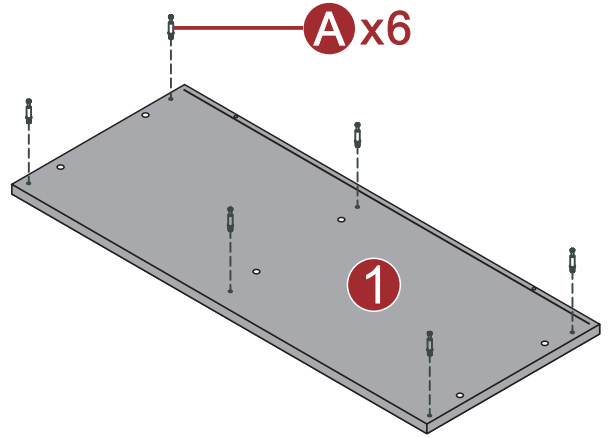

Attach six cam bolt A to panel #1.

 Ax6

11

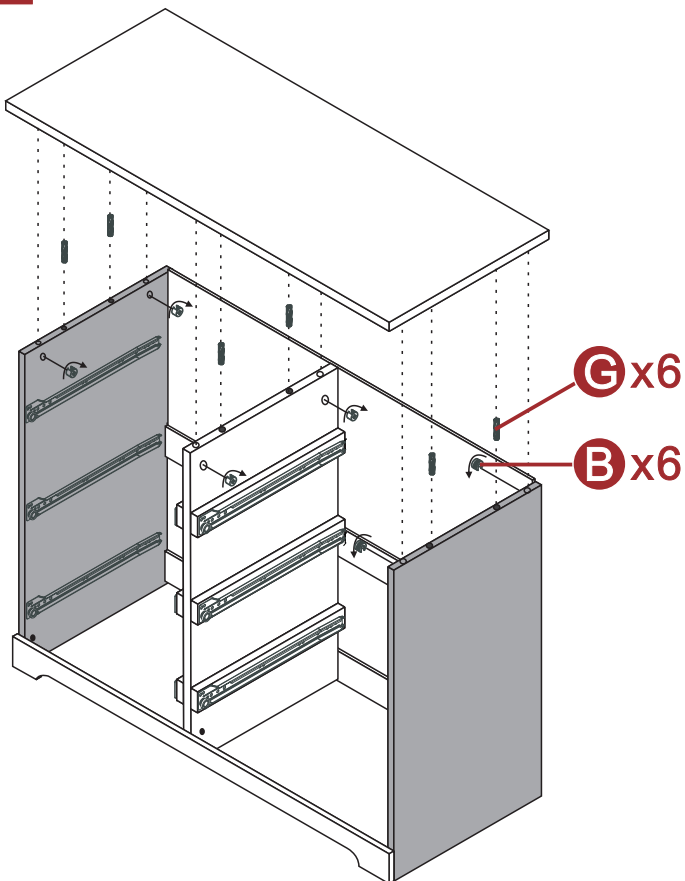

Insert wooden six wooden dowel G to panel #2, #3 and #5, two dowels per panel.

 Gx6
 Bx6

12

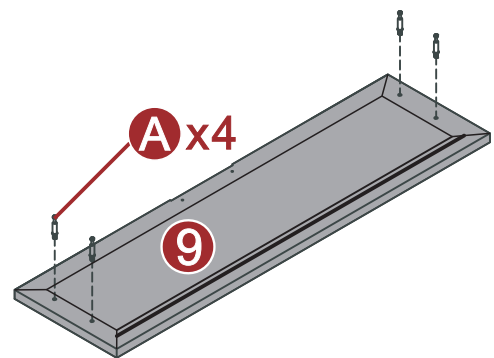

Attach four cam bolt A to panel #9.

 Ax24

x6

13

Attach panel #11 and #12 to panel #9 , then secure them with four cam lock B , two locks per panel.

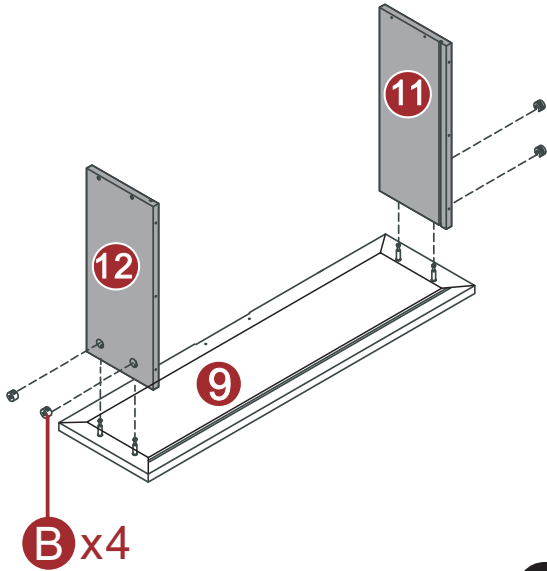

x6

Bx24

14

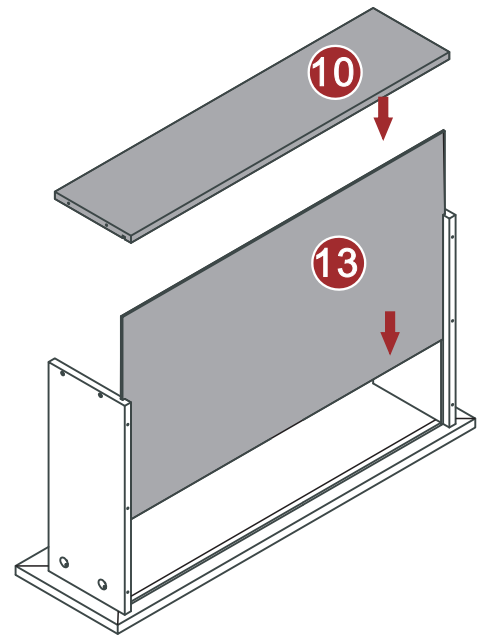

Insert panel #13 , then place panel #10 as shown.

x6

15

Attach panel #10 with four screw F , two screws per end.

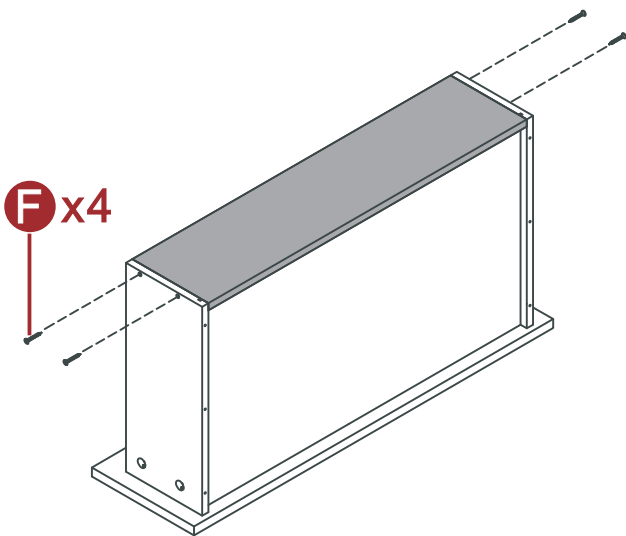



x6

Fx24

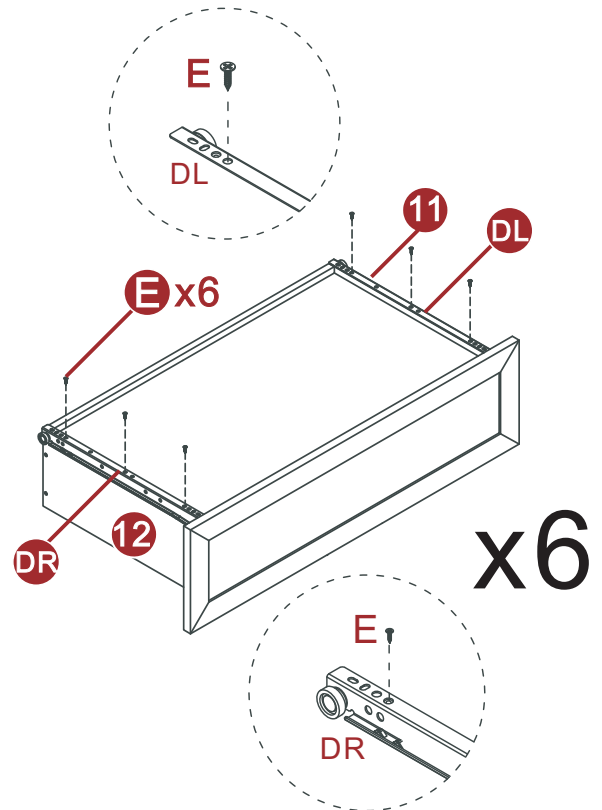
16



Attach part DR to panel #12 with three screw E. Attach part DL to panel #11 with three screw E.

-  DLx6
-  DRx6
-  Ex36

17

Attach handle J to panel #9 with two screw E.

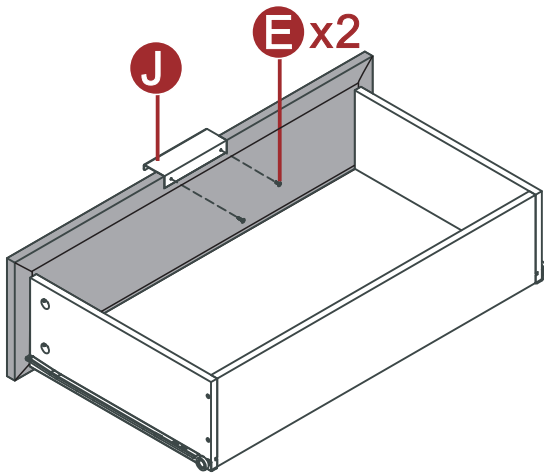

x6

- Jx6
- Ex12

18

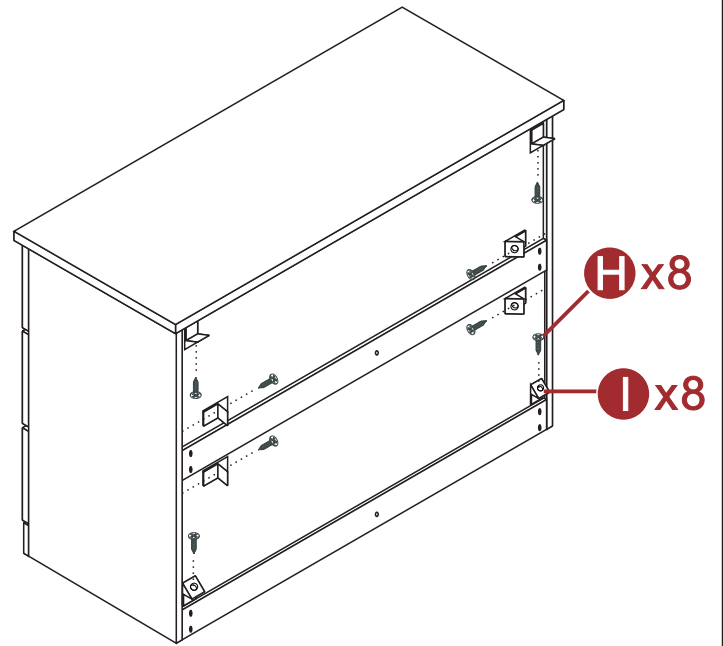

Insert eight corner brace I as shown , then secure with eight screw H.

- Ix8
- Hx8

19

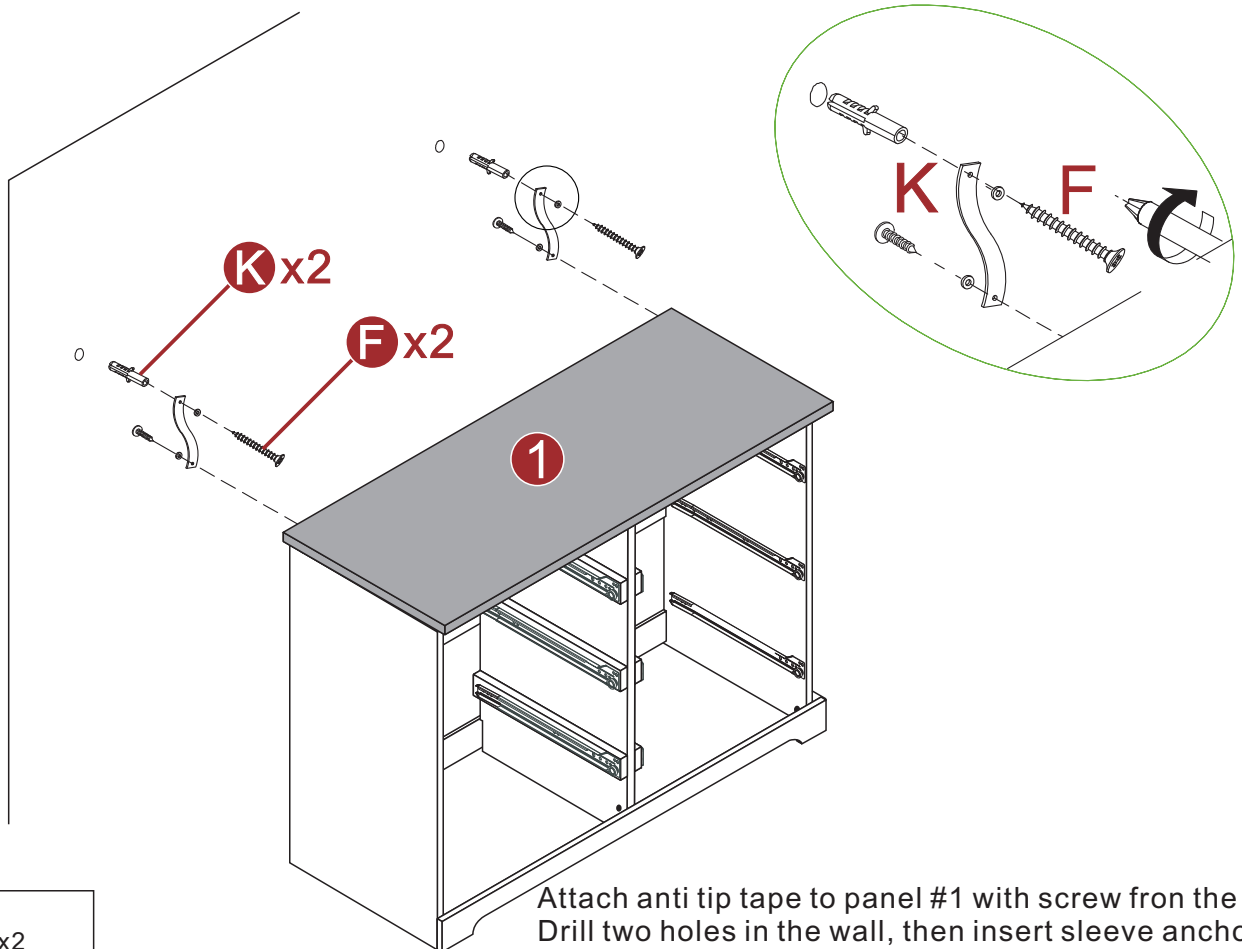

Attach anti tip tape to panel #1 with screw from the kit K. Drill two holes in the wall, then insert sleeve anchors , secure the other end of the tape to the wall with screw F.

- Fx2
- Kx2

20

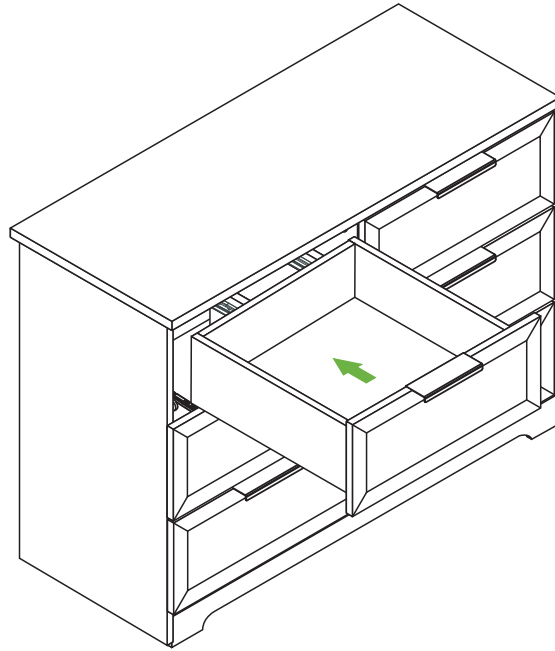

Insert drawers.

21

