

INSTALLATION INSTRUCTIONS

DeerValley®

Sliding Shower Door

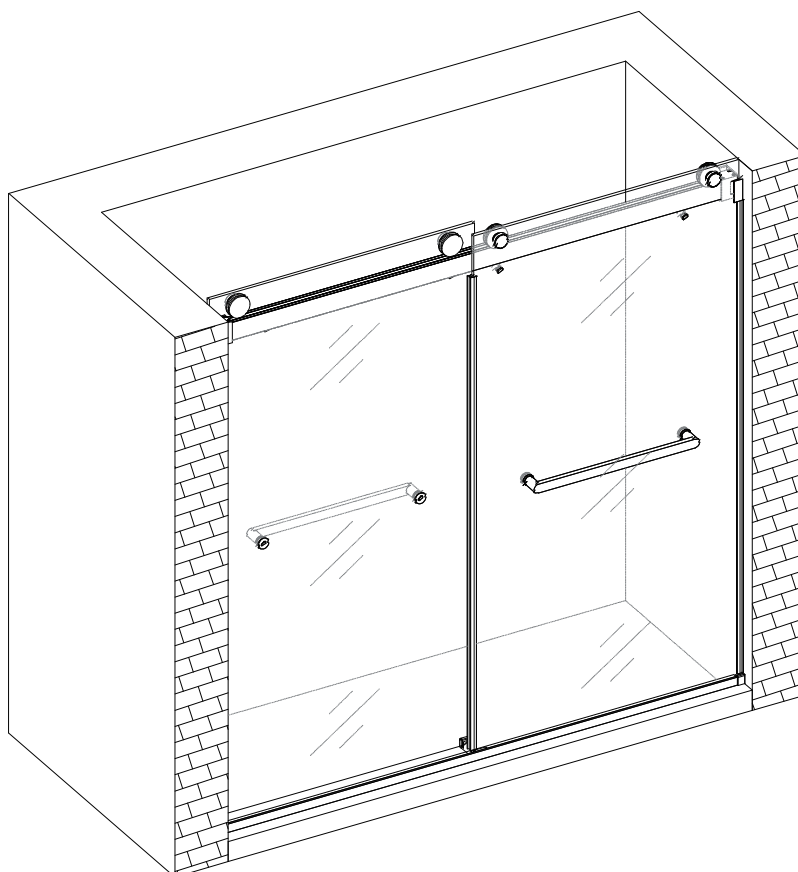

Product Breakdown Diagram

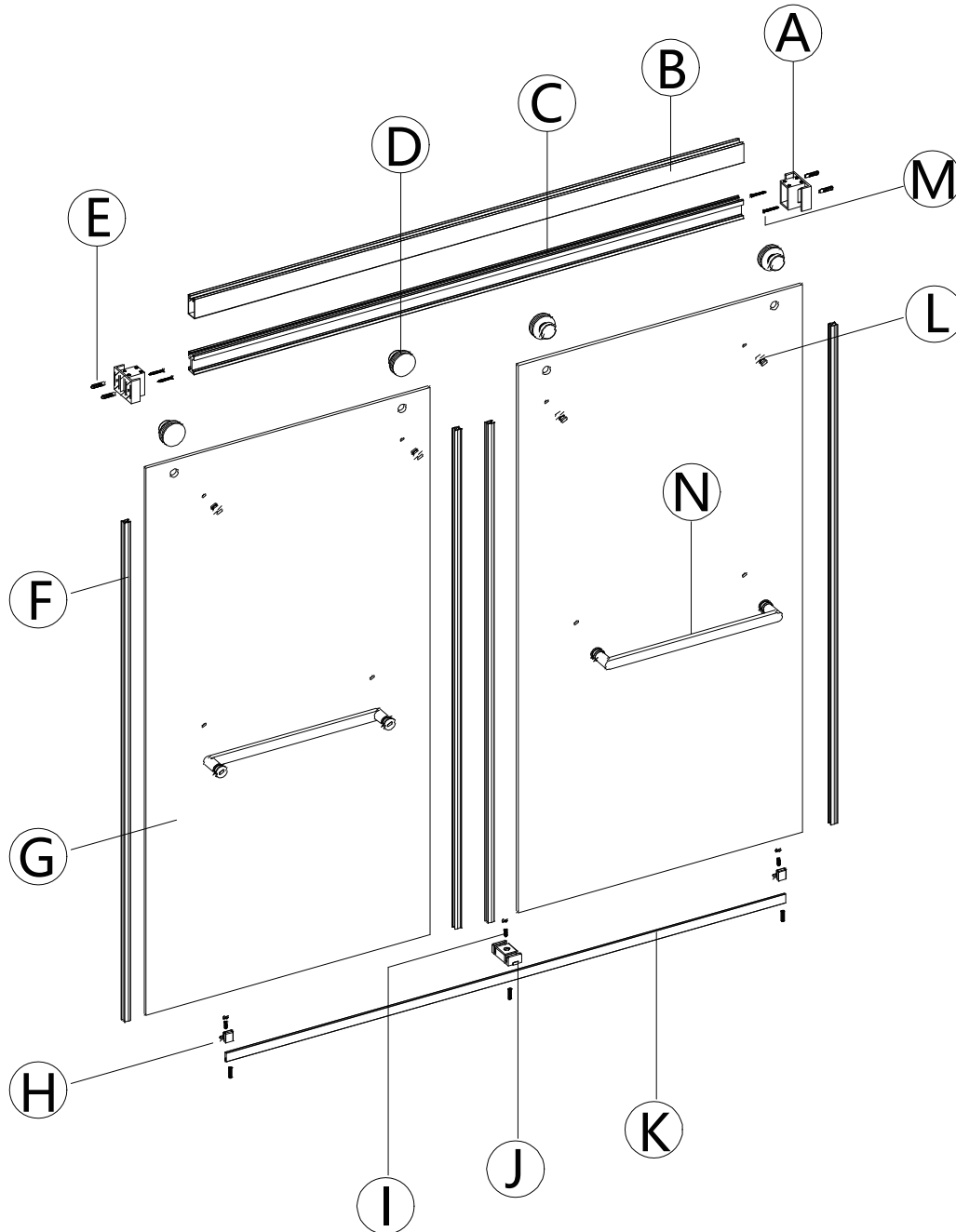

**If you have any questions or concerns
please contact us:**

(+1) 312-626-9466
service@deervalleybath.com

Delivery Notes

Upon receiving the product, please immediately inspect for any transportation damage, missing parts, or manufacturing defects.





Cleaning and Maintenance

1. For daily cleaning of the bathtub door, you can use common liquid detergent and a soft cloth.
2. For stains, use a clean soft towel or a small amount of neutral soap solution or toothpaste to gently wipe.
3. To keep the glass surface shiny, you can use a polishing agent for polishing treatment.

Precautions

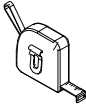
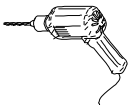
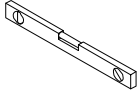
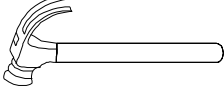
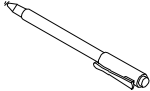
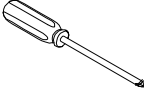
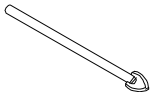
1. Do not use acidic, alkaline, or sharp tools during cleaning to avoid damaging the glossiness of shower trays, glass, metal materials, and other accessories' surfaces.
2. Avoid using strong detergents containing acetone or ammonia ingredients; when disinfecting, avoid using disinfectants containing formic acid and formaldehyde to prevent damage to the product's surface glossiness.
3. Do not allow body or hard objects to come into contact with or impact the glass surface during showering to avoid accidents.
4. Regularly check the usage condition of the bathtub door, and if any abnormalities are found, please contact the after-sales service department promptly.

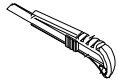
Tool List (Not Included)

Material Name	Illustration	Material Name	Illustration
Tape measure		Electric drill	
Spirit level		Hammer	
Marker pen		Screwdriver	
6mm drill bit		Allen wrench	
Utility knife		Silicone sealant	

Accessory List

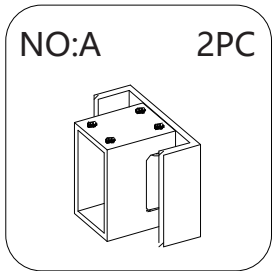

Guide Rail Wall Cover

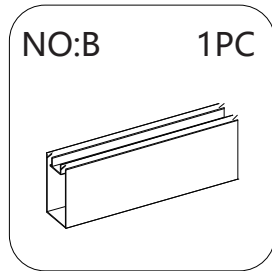

Guide Rail Sleeve

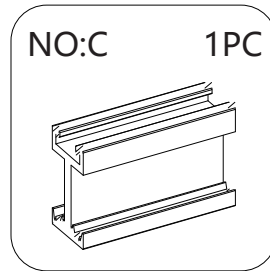

Inner Guide Rail

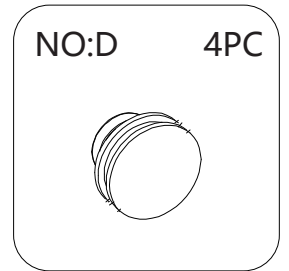

Pulley

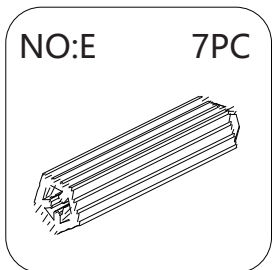

Wall Entry Plug

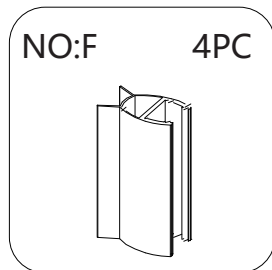

Collision Prevention Strip

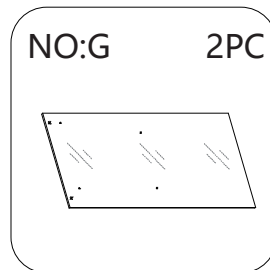

Door Glass

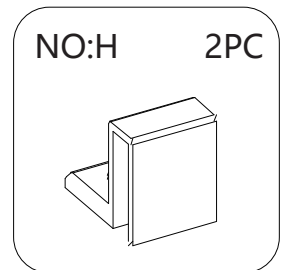

Lower Water Stop Bar
Fixing Parts

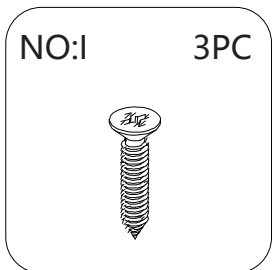

Screw-A

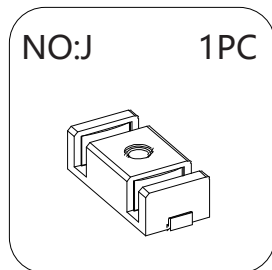

Lower Slider

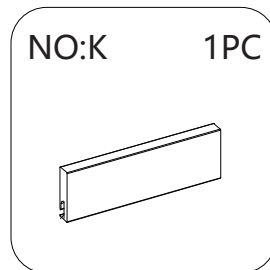

Lower Water Stop Bar

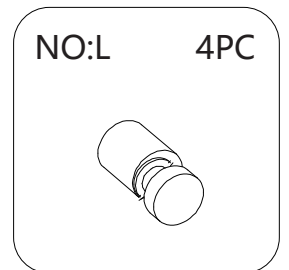

Pulley Anti-Detachment
Component

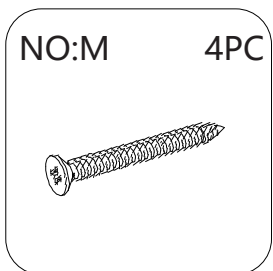

Screw-B

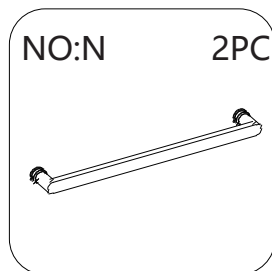

Handle

Drawings may not exactly define contour of the product.

Installation steps

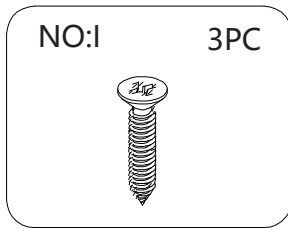

Screw-A

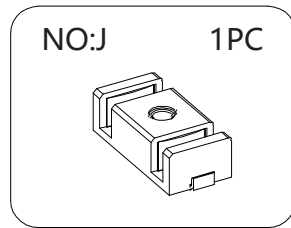

Lower slider

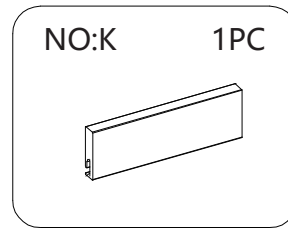

Lower Water Stop Bar

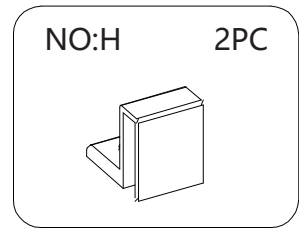

Lower Water Stop Bar Fixing Parts

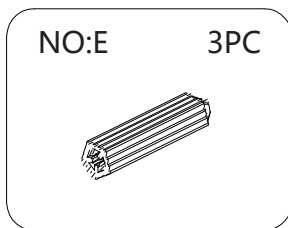

Wall Entry Plug

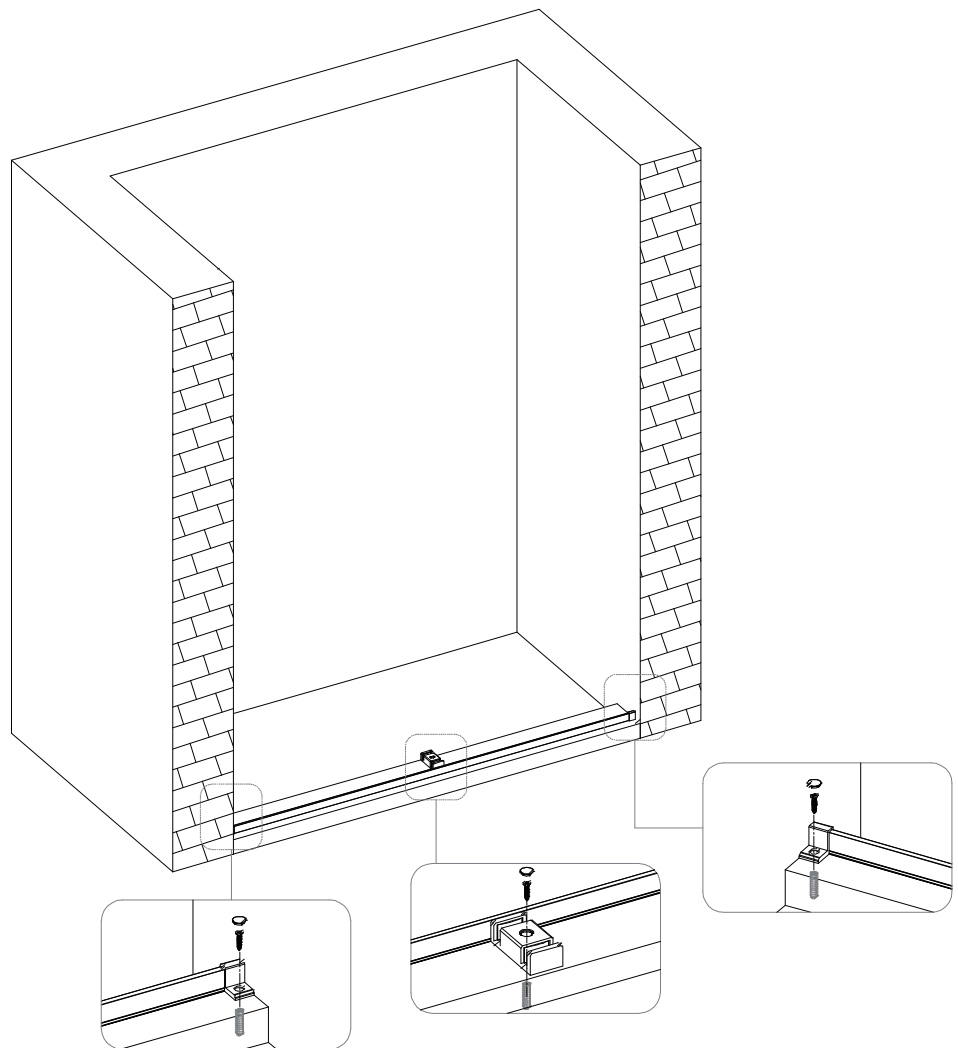
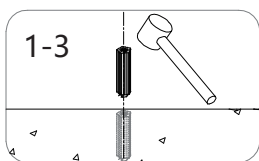
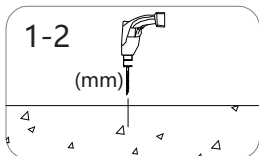
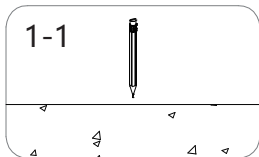

Step 1: Installation of Lower Water Stop Bar

- 1-1. Start by placing the lower water stop bar on the base/floor surface. Install each fixing part separately at both ends and mark the positions using a marker pen.
- 1-2. Use a drill bit to create holes for marking points, with a diameter of 6mm.
- 1-3. Insert wall plugs into the holes made on the base/floor surface, ensuring that the end face of the wall plug is flush with the base/floor surface.

Drawings may not exactly define contour of the product.

Installation steps

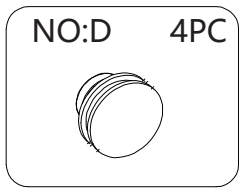

Pulley

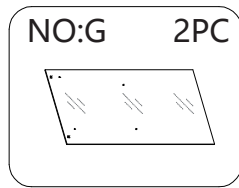

Door Glass

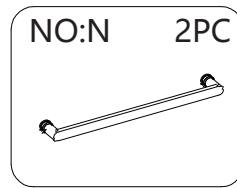

Handle

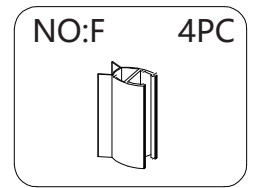

Collision Prevention Strip

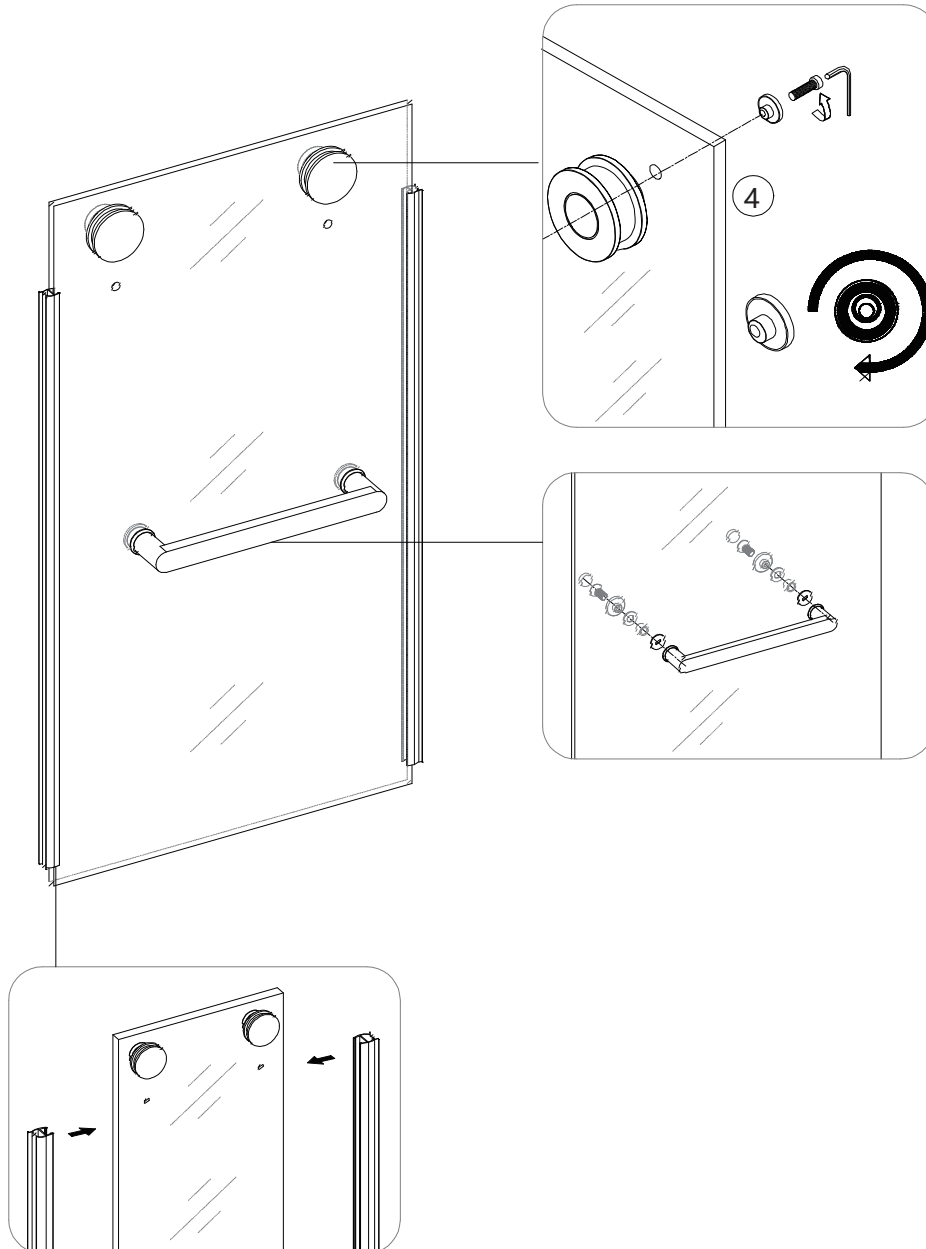

Step 2: Assemble the Door Glass Accessories

Install the pulleys and anti-collision strips.

(The two doors are opposite, please pay attention to assembly.)

Drawings may not exactly define contour of the product.

Installation steps

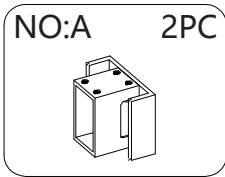

Guide Rail Wall Cover

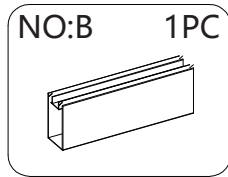

Guide Rail Sleeve

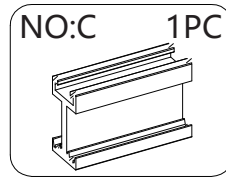

Inner Guide Rail

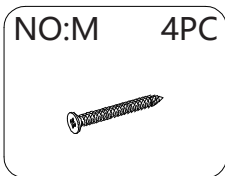

Screw-B

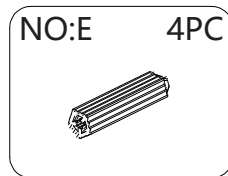

Wall Entry Plug

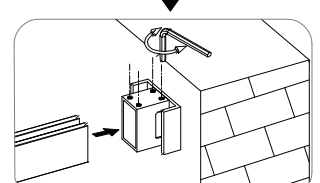
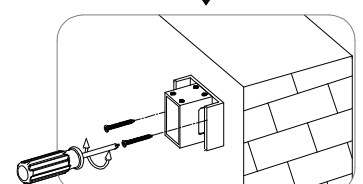
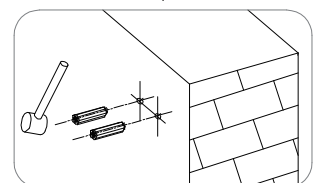
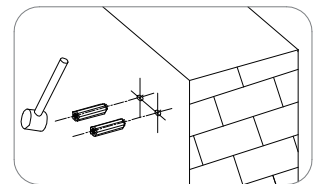
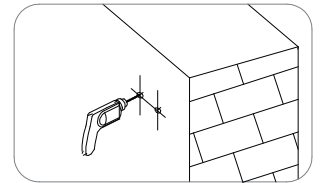
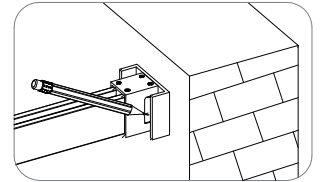
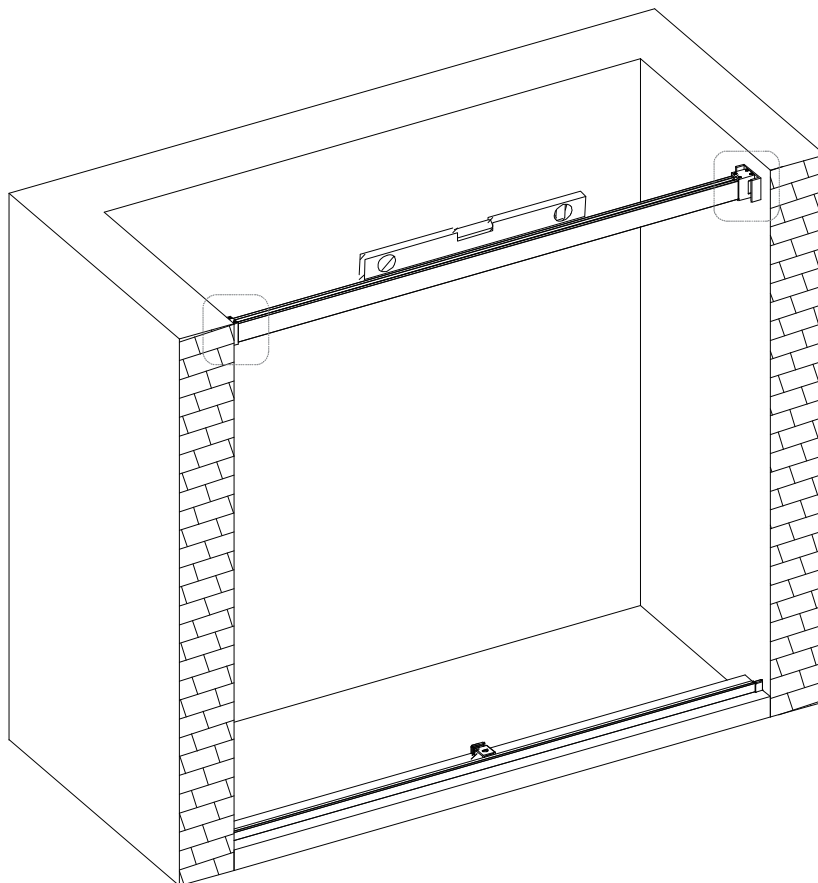

Step 3: Installation Sequence of Upper Guide Rail (Note: Ensure Horizontal Alignment)

Drawings may not exactly define contour of the product.

Installation steps

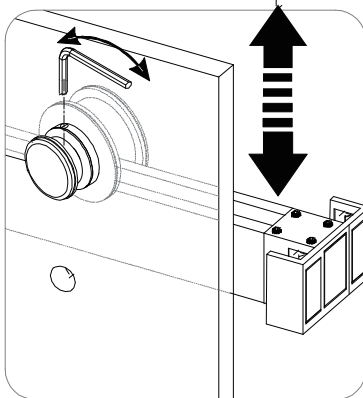
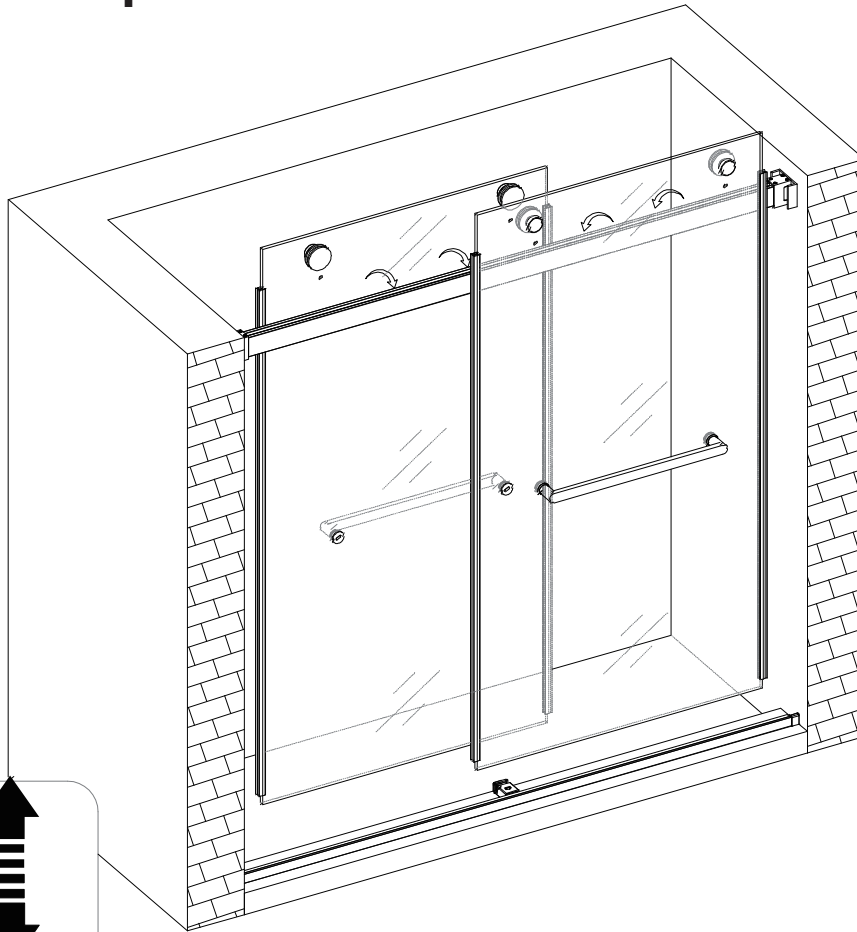

Debugging Guidelines for Door Glass.

Step 4: Hanging the Door Glass / Adjusting Horizontal Alignment
4-1. When hanging door glass, pay attention to the inner and outer door grooves. They are opposite each other, as are the handles. Do not put them in backwards or the door glass will not move.

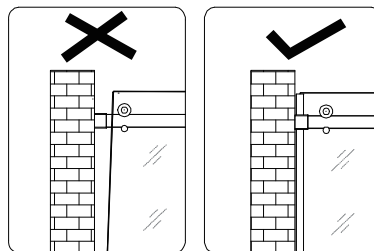

The door glass is considered qualified when it is in a vertical state without shaking.

Drawings may not exactly define contour of the product.

Installation steps

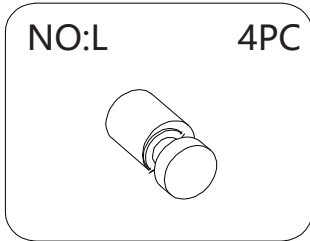

Pulley Anti-Detachment Component

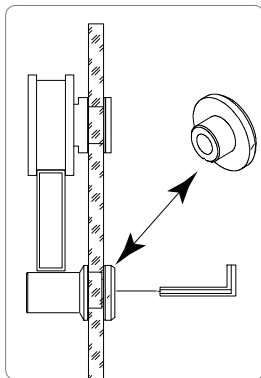
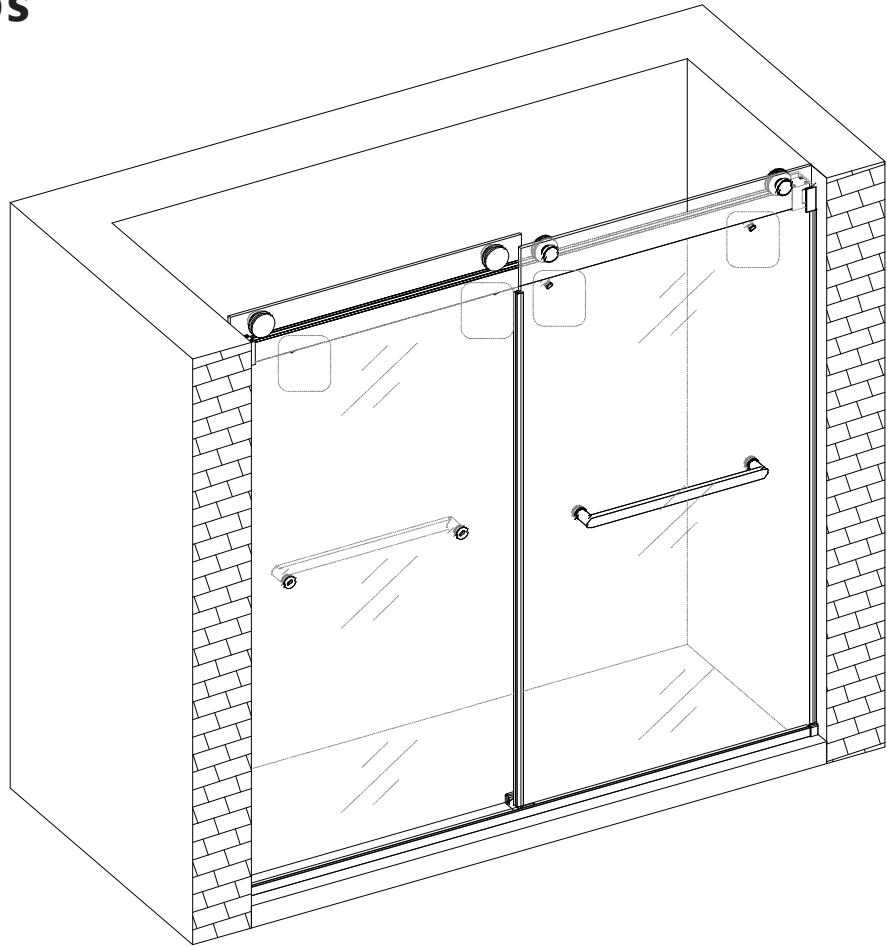

Debugging the anti-detachment positioning component of the door glass.
(The component should be snug against the guide rail.)

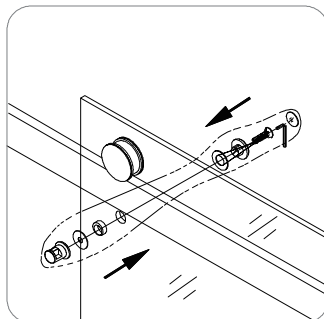

Installing anti-detachment positioning parts for the door glass.

Step 5: Install Anti-Detachment Accessories

Drawings may not exactly define contour of the product.

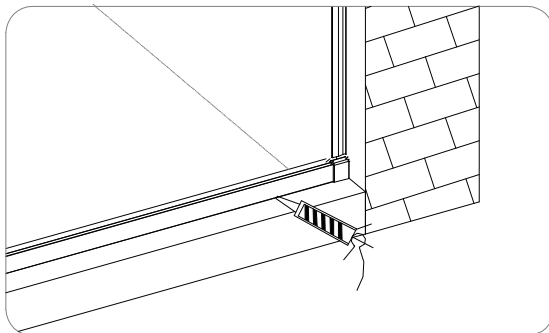
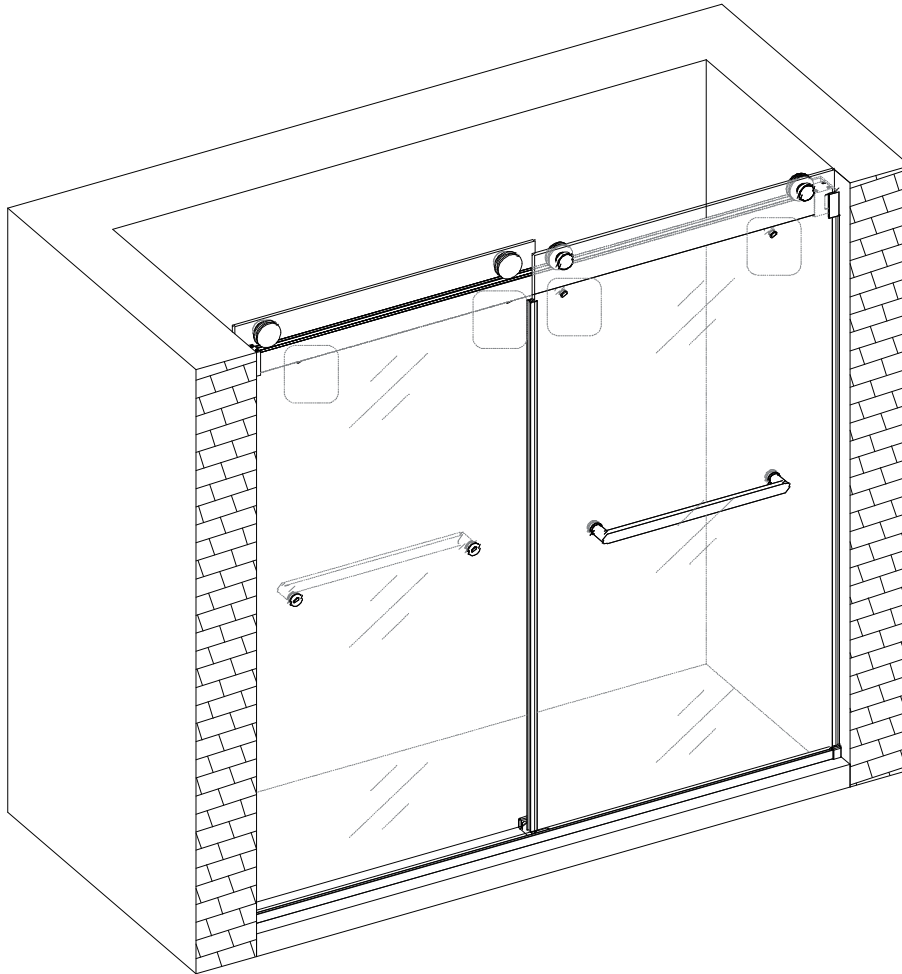
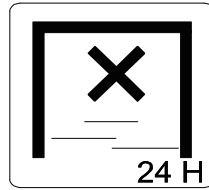
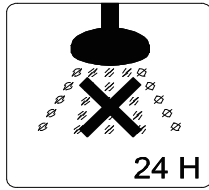
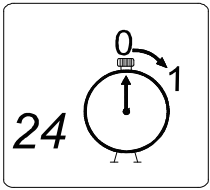

After installation, confirm that there are no abnormalities, and apply glass glue for waterproofing.

Drawings may not exactly define contour of the product.

LIMITED WARRANTY COVERAGE

1 YEAR LIMITED WARRANTY

DeerValley products are made with quality materials and excellent craftsmanship to provide the customers a long-lasting product. In the case of any defects in materials or craftsmanship under regular use were inspected in the first one year of delivery, DeerValley will provide replacement parts at no charge, or at its option, replace any product or part of the product that is deemed defective, under normal installation, use, service and maintenance. This warranty applies only to the original purchaser. Proof of purchase will be required in the case of a claim. **SCRATCHES ARE NOT COVERED UNDER WARRANTY.**

The manufacturer warrants this product to be free of manufacture defects during the above mentioned warranty time. Please keep a copy of the original invoice as proof of purchase.

DeerValley will, as its option, (1) repair or replace the defective part(s) or product(s) at no charge; (2) issue a refund of the original purchase price of the product(s) (Valid within 30 days from the date of delivery); or (3) issue a credit to be applied toward the purchase of a new DeerValley product shipping/delivery charges may apply and are in DeerValley sole discretion.

DeerValley recommends the installations to be made by a licensed, professional plumber. DeerValley will not be held responsible for any damage or product failure due to improper installation, misuse, or failure to use a licensed professional. DeerValley is not responsible for any removal or installation cost.

This limited warranty shall not apply to goods which have been subject to accident, negligence, improper installation, product abuse, product misuse, or use of cleaners containing abrasives, alcohol or other organic solvents, whether performed by a contractor, service company, or yourself, are excluded from this warranty.

DeerValley responsibility under this limited warranty is limited to only to replacement parts and no other costs. DeerValley will not be responsible for labor charges and/or damage incurred by installation, repair or replacement, nor for any indirect incidental or consequential damages, losses, injury or costs of any nature relating to this product Except as provided by law, this limited warranty is in lieu of and excludes all other warranties, conditions, and guarantees, whether expressed or implied, statutory or otherwise, including without restriction those merchantability of fitness for use.

RESPONSIBILITIES OF OTHERS

Inspecting the unit prior to installation is the responsibility of the installer or building contractor who acts on behalf of the user. They are responsible for ensuring the unit is free of defect or damage.

Notices are placed on and in the unit and on the shipping carton advising the installer of this responsibility.

In the event of a problem, the unit must not be installed. DeerValley is not responsible for failures or damage that could have been discovered, repaired, or avoided by proper inspection and testing prior to installation.

Damage occurring in transit is the responsibility of the carrier. The user or installer **MUST** open the crate and inspect the unit for damage when it is delivered. If damage is discovered, it must be reported immediately to the seller and the carrier in writing, and an inspection requested. Failure of the carrier to respond should be reported to the seller and the carrier. Your freight claims should be filed promptly thereafter.

LIMITATIONS AND EXCLUSIONS

This warranty does not cover instances of negligence, misuse, abuse, improper installation, carelessness, accident, hard water or mineral deposits, exposure to corrosive materials, misapplication, damages caused by improper maintenance, alteration of the product, or failure to follow care or installation instructions enclosed with your product. The warranty becomes invalid if the DeerValley product undergoes any alterations or if attempts are made to carry out repairs using unauthorized accessories or parts from DeerValley.

DeerValley will not be liable for loss of use of the DeerValley products, inconvenience, or any other incidental or consequential costs, expense or damages. Please note that some states do not allow the exclusion or limitation of incidental damages.

DISCLAIMER

Except as expressly provided, there shall be no warranty or obligation, express or implied, oral or statutory. No dealer or other person has the authority to make any warranties or representations concerning DeerValley or its products. In no event shall DeerValley be held responsible for any such warranties or representations.

WARRANTY SERVICE

NOTE: When requesting warranty, be sure to have the following:

- Copy of original invoice
- Date of installation
- Description and pictures of defect
- Model number or description of model

To obtain warranty service and replacement part, please contact DeerValley Customer Service. DeerValley will determine whether to repair or replace your product, issue a refund, or issue a credit.