

2' Garden Gnome Bridge

(Unassembled Kit)

Tools Required:

- You will need a #2 Philips or Robertson driver
- For your convenience we use Recex rust resistant zinc plated hardware.

Package Contents:

- (A) Sides...2
- (B) Foot Planks...10

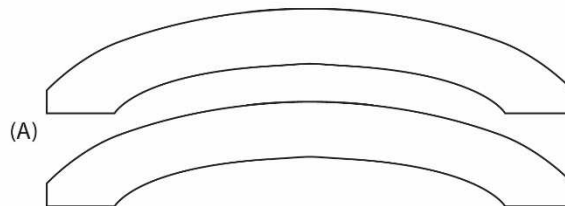

Hardware:

- 1-1/2" Screw ...20

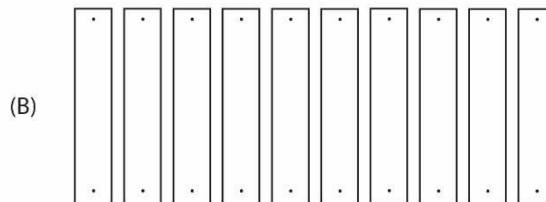

STEP 1. Align Sides

- Place Bridge Sides on edge and butt one end up to a wall to keep ends flush
- Use a foot plank to set the sides 22-1/2 inches apart (outside edge to outside edge).
- Align screw holes in foot planks with sides and allow planks to overhang each side by 1/2 inch
- To keep alignment in place, attach a foot plank to both ends of bridge

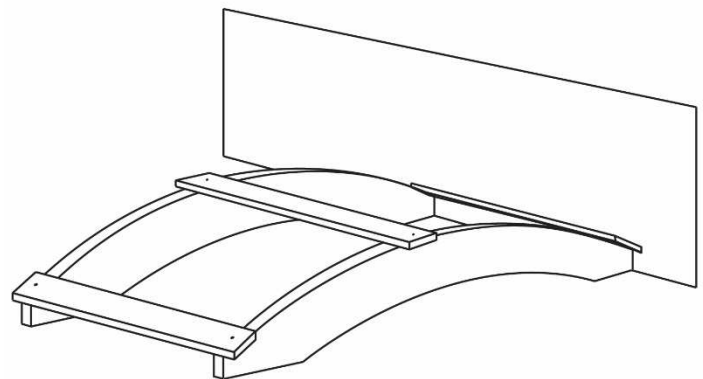

STEP 2. Attach Foot Planks

- Starting at the middle, lay out the remaining Foot Planks, and work your way to the ends
- Ensure the ends of all Foot Planks are flush, then attach using 1-1/2-inch screws
- Your new bridge is ready for use

