

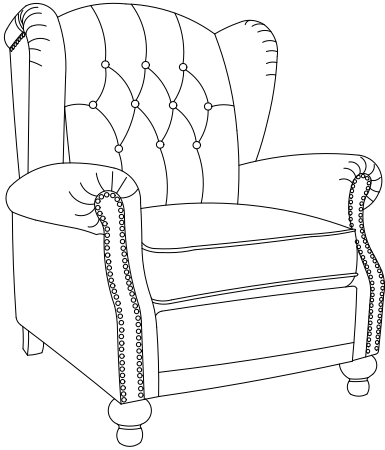

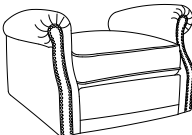

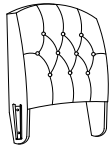

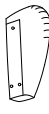

Assembly Instructions

1. Remove all parts from the carton and place them on a protected surface or carpet.

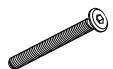

N0.	Parts	N0.	Parts
A	 *1	B	 *1
C	 *1	D	 *1
E	 *2	F	 *2
① Long Blot	 *7	② Short Blot	 *3
③	 *10	④	 *10
⑤	 *1		

2. Take out the wood legs (E & F) & HARDWARE (①&②&③&④&⑤) out from the Back(B).

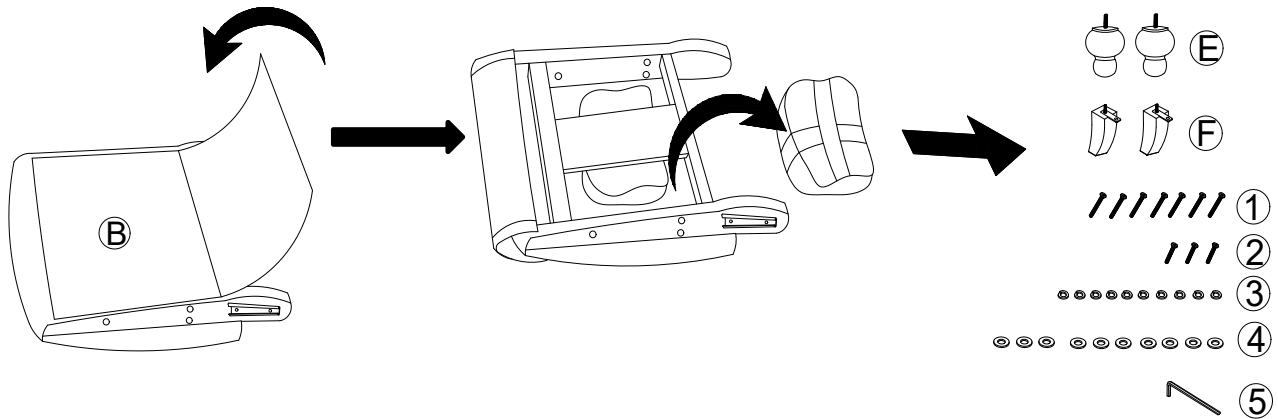

3. Attach the wood front legs (E) & back legs (F) to the corners of the seat cushion (A) as shown. Be careful not to hurt your hand when attach the wood back leg (F).

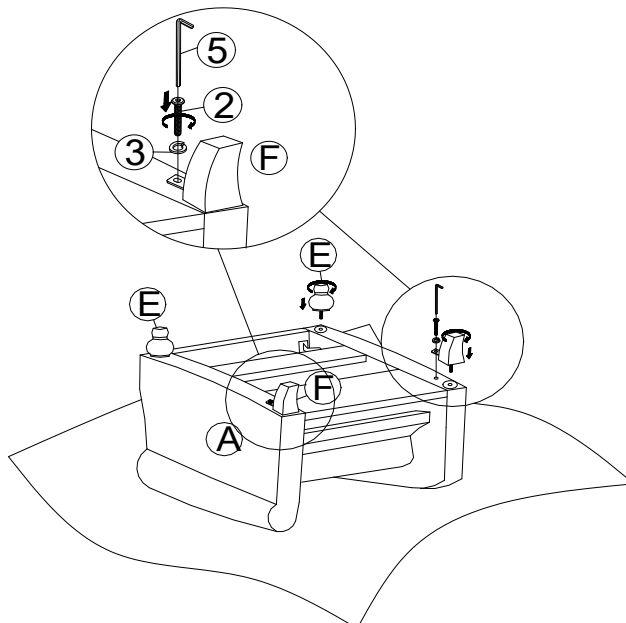

4. Turn the seat upside down, be sure to not hurt the wood legs.

5. Attach the back cushion (B) to the seat cushion (A) by sliding the receivers into the mechanism posts located on the seat cushion (A).

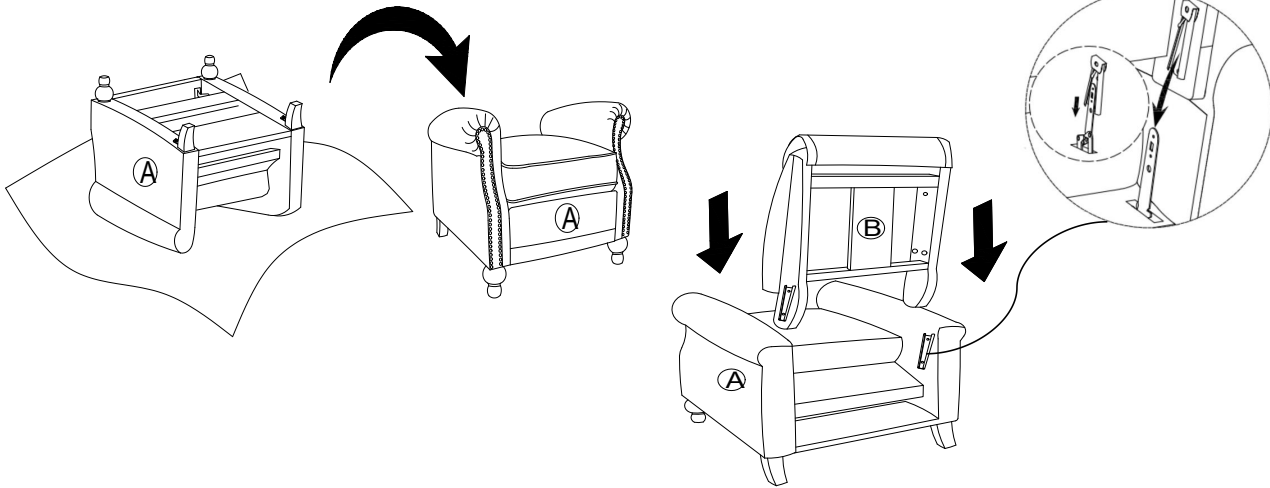

6. Attach the back wing (C) & back wing (D) to the back (B) as shown. Be careful not to hurt your hand when attach the back wings.

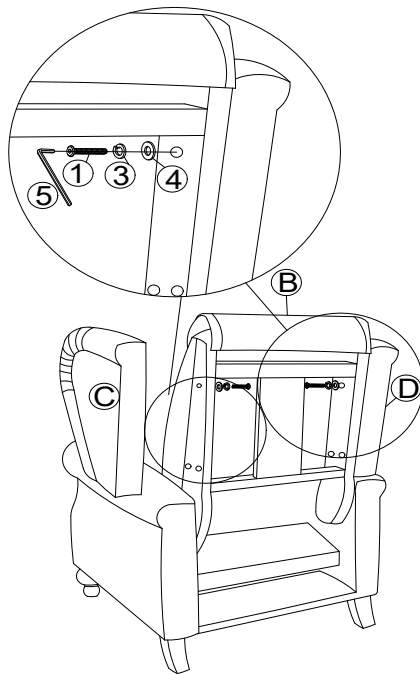

7. Stick the back flap under the bottom of the seat cushion.

