

ASSEMBLY INSTRUCTIONS & PARTS IDENTIFICATION

3 DRAWER SERVER

Thank you for purchasing this quality product. Be sure to check all packing material carefully for small parts that may have come loose inside the carton during shipment.

Key Parts		
No	Q'Ty	Description
1	4 pcs	LEGS
2	5 pcs	DOOR/DRAWER PULLW/SCREW
3	3 pcs	COMPLETE DRAWER
4	3 pcs	DRAWER STOP
5	3 pcs	DRAWER GUIDE(WOOD ON WOOD)
6	1 pc	DOOR-RIGHT SIDE FACING
7	1 pc	DOOR-LEFT SIDE FACING
8	4 pcs	DOOR HINGE
9	1 pc	SHELF
10	4 pcs	FLOOR GLIDE
11	1 set	ANTI-TIP KIT

Hardware kit		
No	Description	Q'Ty
A	Bolt 1/4" x 2 1/3"	12 pcs
B	Lock washer 5/16"	12 pcs
C	Flat washer 5/16"	12 pcs
D	Allen Key	1 pc

PLEASE NOTE:
To help prevent the possibility of tip-over, install the Anti-tip restraint provided.

DETAIL A

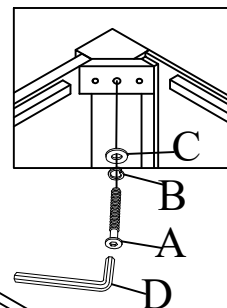

DRAWER STOP ENGAGED DRAWER STOP DISENGAGED

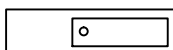
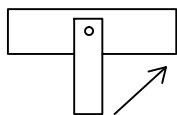

Rotate vertical stop to the horizontal position to disengage

STEP 1

- Carefully remove all Drawers complete from the Storage box. Then lay Storage box backside down on a smooth flat surface to prevent scratches.
- Insert Bolt (A), Flat washer (C), Lock washer (B) with Allen key (F) through holes inside Store box to Legs. See (DETAIL A). Do not fully tighten at this stage until all parts are in position.
- Carefully insert Shelf frame into designated locations then insert Bolt (A), Flat washer (C), Lock washer (B) with Allen key (F) through holes inside Shelf frame to Legs. See (DETAIL B).
- Once all parts are in place, tighten all bolts.

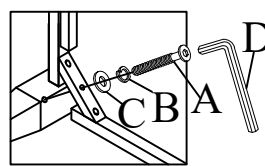
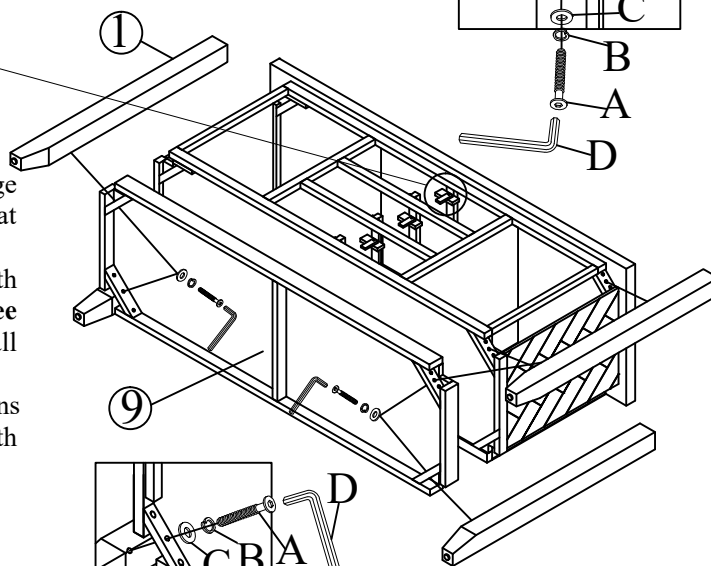

DETAIL B

STEP 2

- Carefully put the Drawers back in place and engage the drawer stop. Attach the Anti tip hardware.

