

# Assembly Instructions

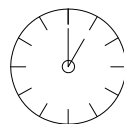

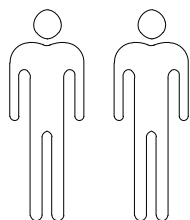

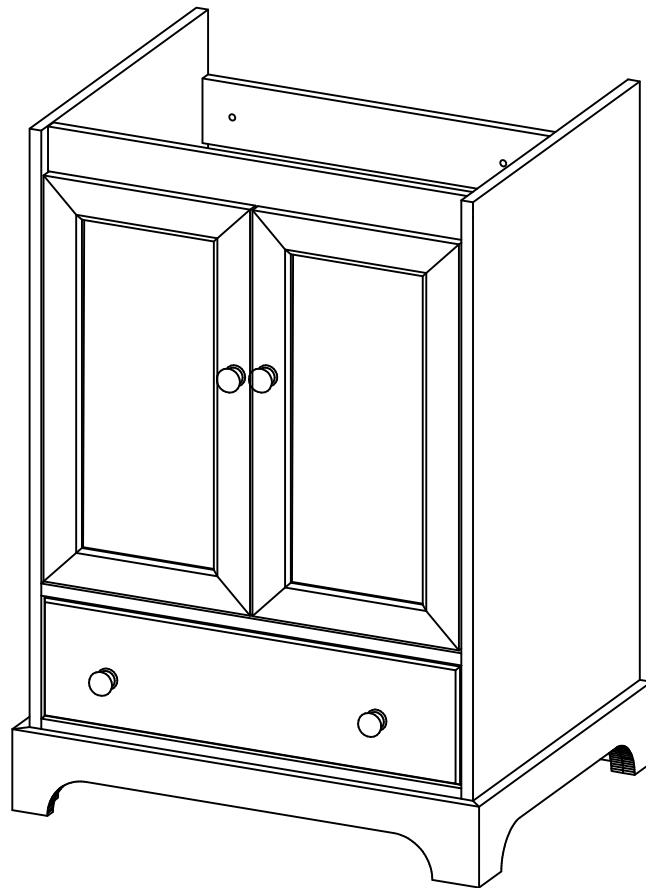

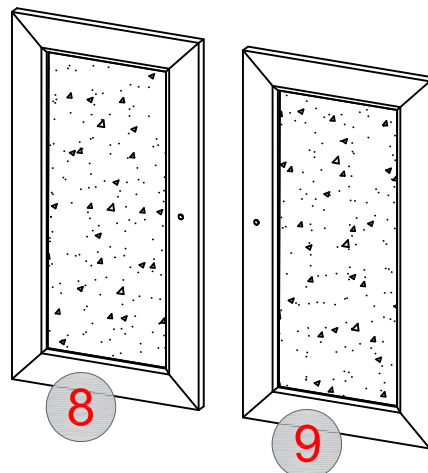
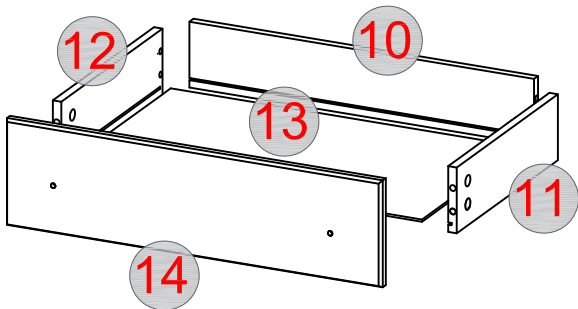
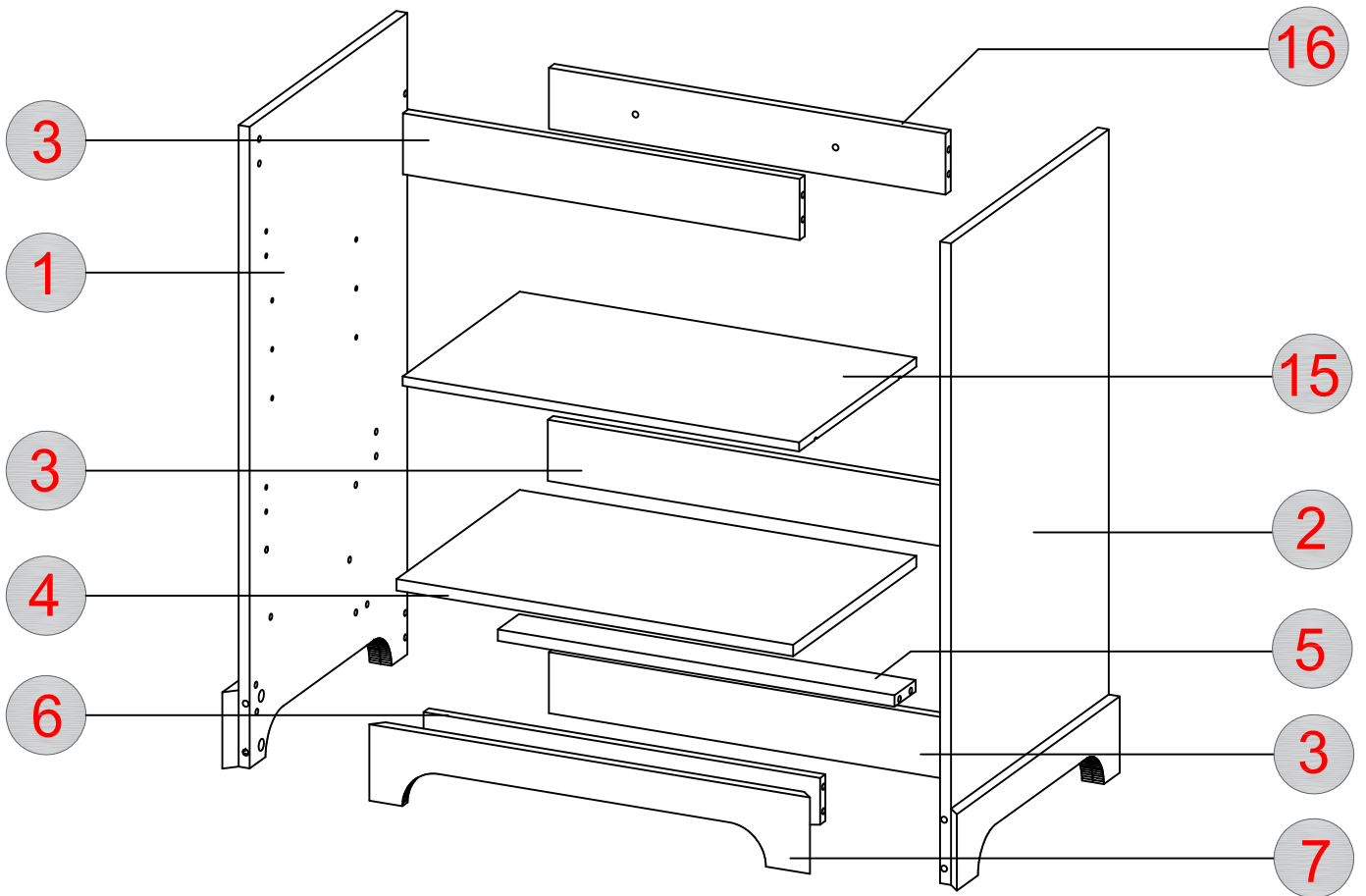

assembly need  
120 Mins



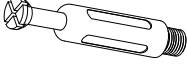

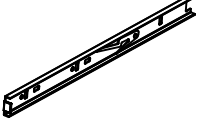
# HARDWARE LIST

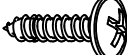
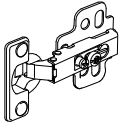
- 1 X1
- 2 X1
- 3 X3
- 4 X1
- 5 X1
- 6 X1
- 7 X1
- 8 X1
- 9 X1
- 10 X1
- 11 X1
- 12 X1
- 13 X1
- 14 X1
- 15 X1
- 16 X1

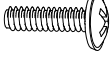

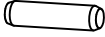
# HARDWARE LIST

Name	Part	Qty.	Spare
A		40	2
B		32	2
C1		2	
C2		2	
D	 3.5*12	8	
E	 4*25	1	
F		4	
G	 4*14	24	2
H		4	
I	 4*18	2	

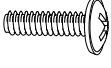
Name	Part	Qty.	Spare
J		8	1
K		4	
L		4	
M		2	
N	 4*50	2	
O	 4*22	2	

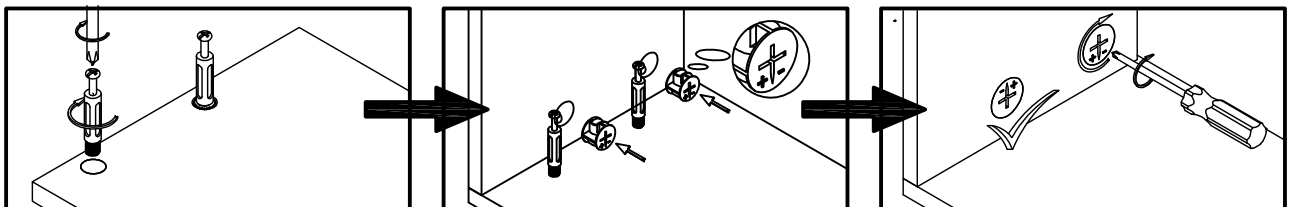

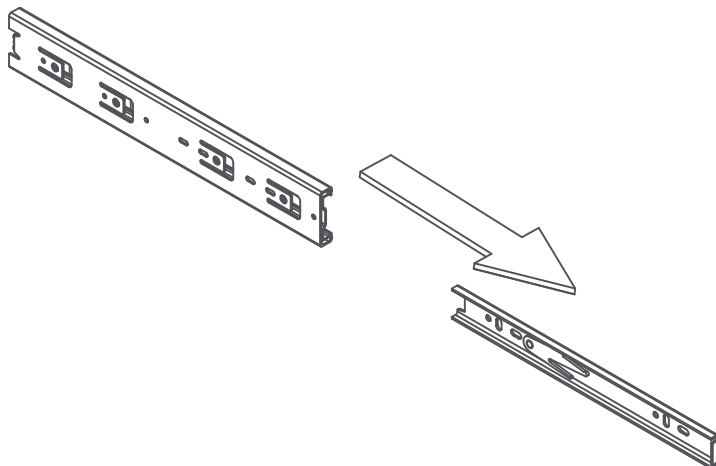
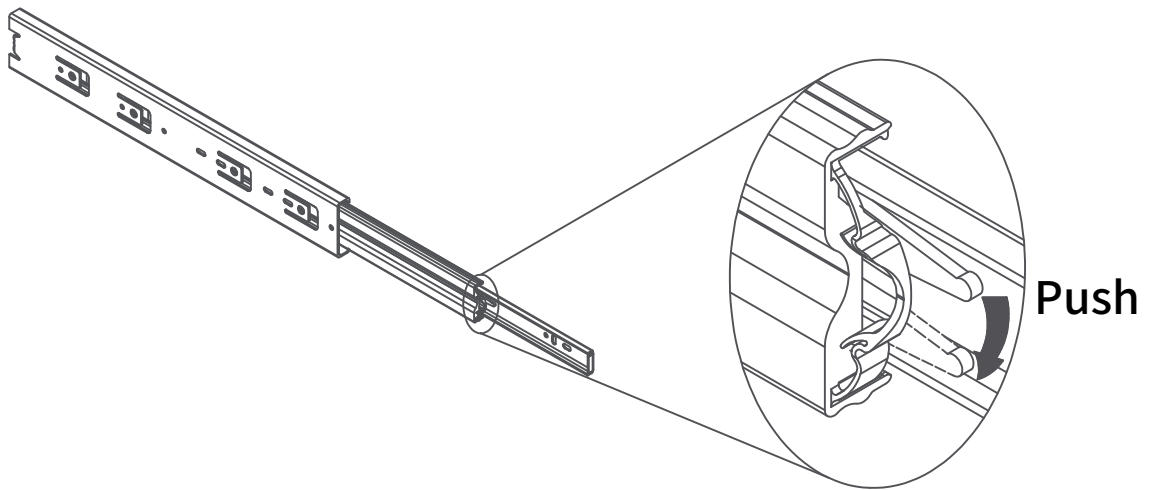
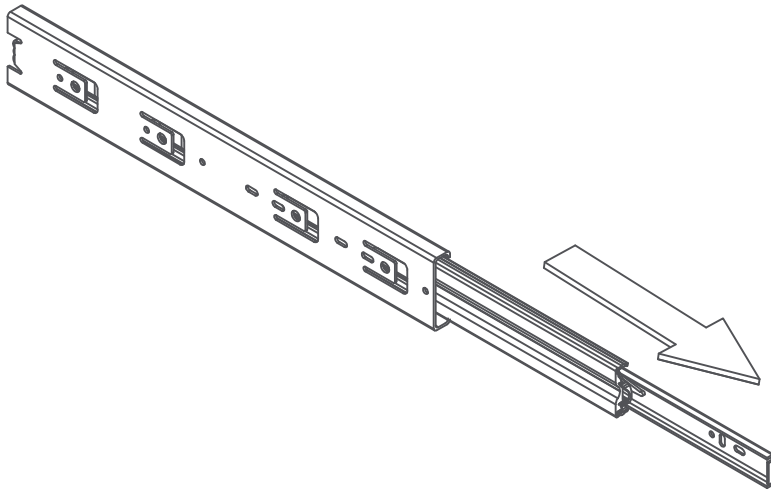
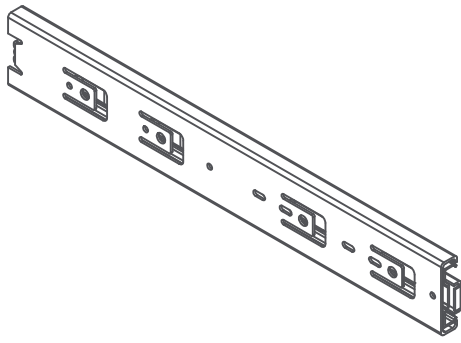

# STEP 1

**C1** x2 pcs

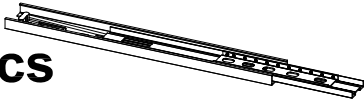

**D** x4 pcs

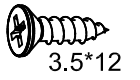

3.5\*12

**C1**

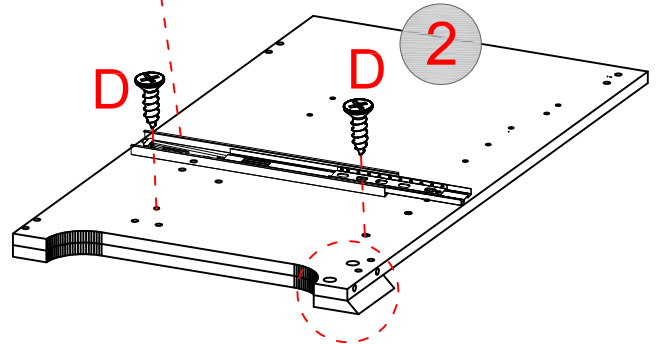
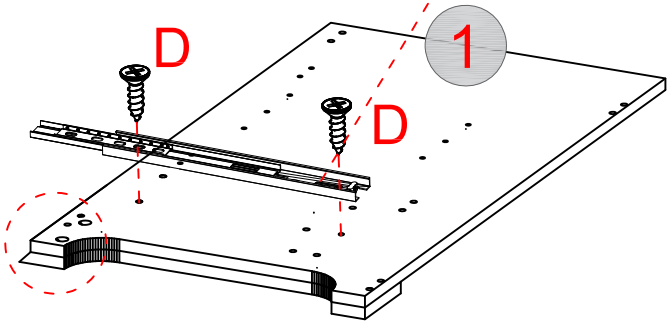
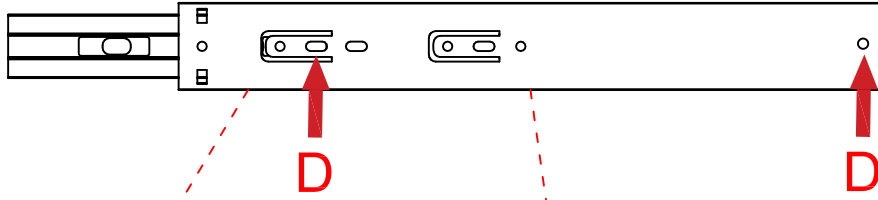

# STEP 2

**A** x14 pcs

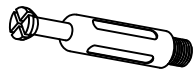

**B** x14 pcs

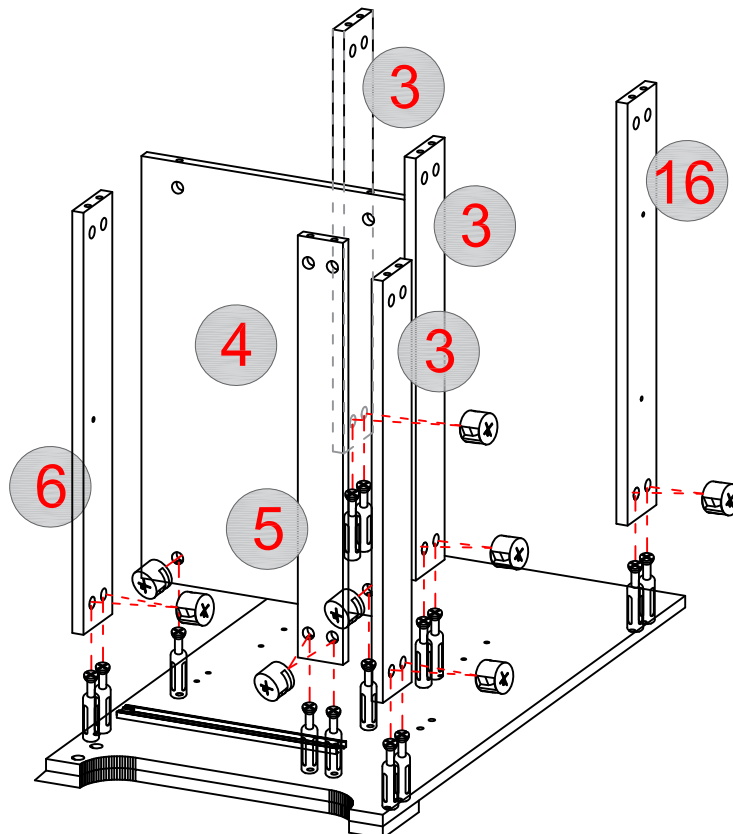

# STEP 3

**A** x14 pcs 

**B** x14 pcs 

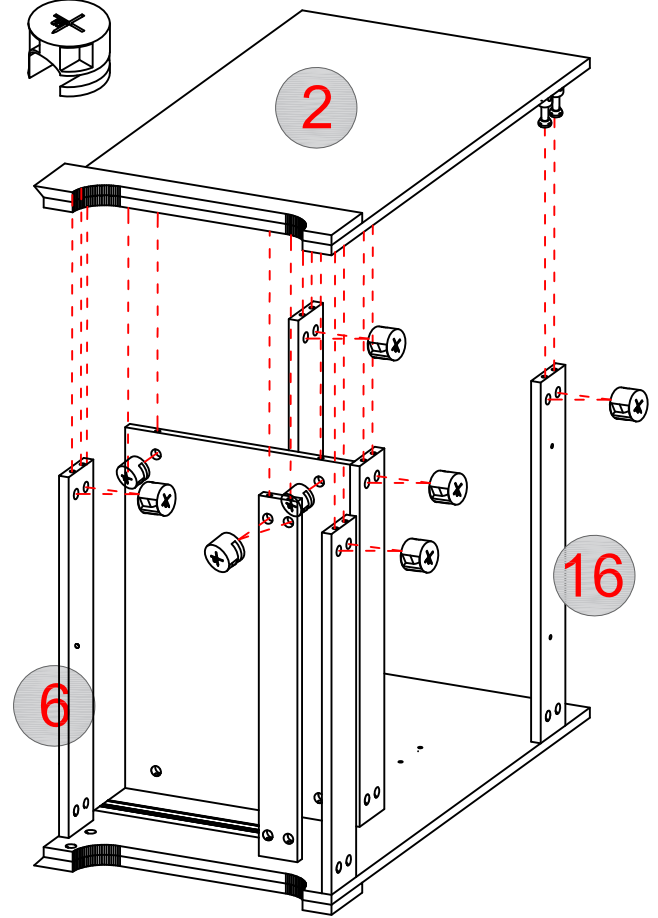
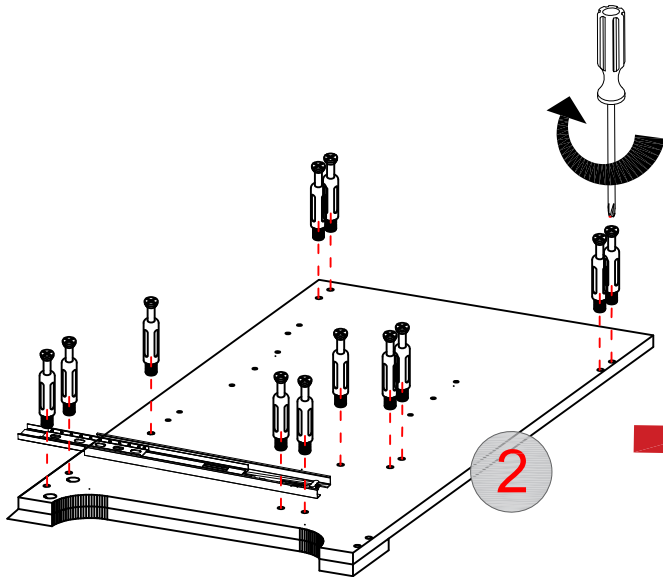

# STEP 4

**A** x4 pcs 

**B** x4 pcs 

**E** x1 pc 

4\*25

**L** x4 pcs 

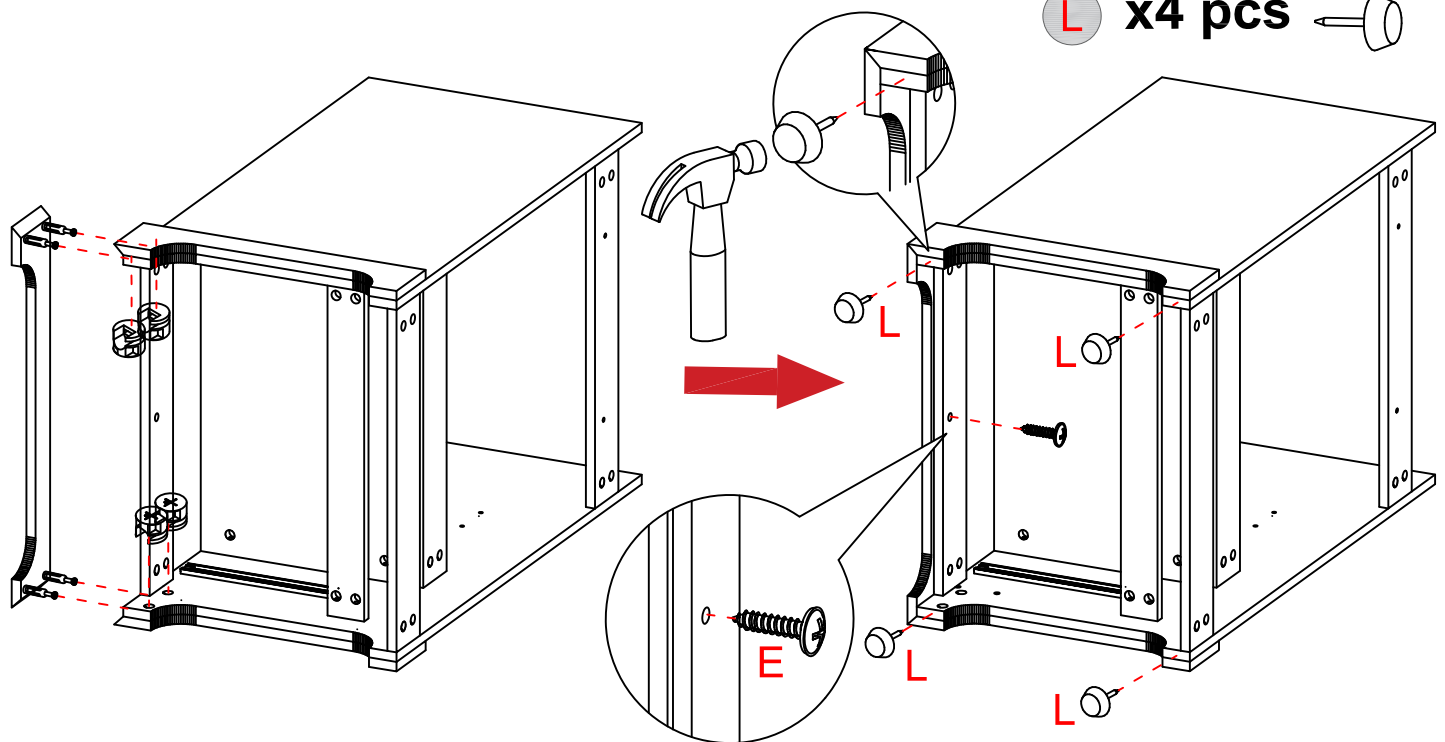

# STEP 5

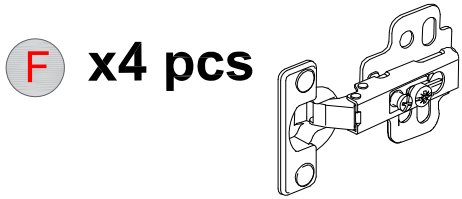

This is the location for the hole

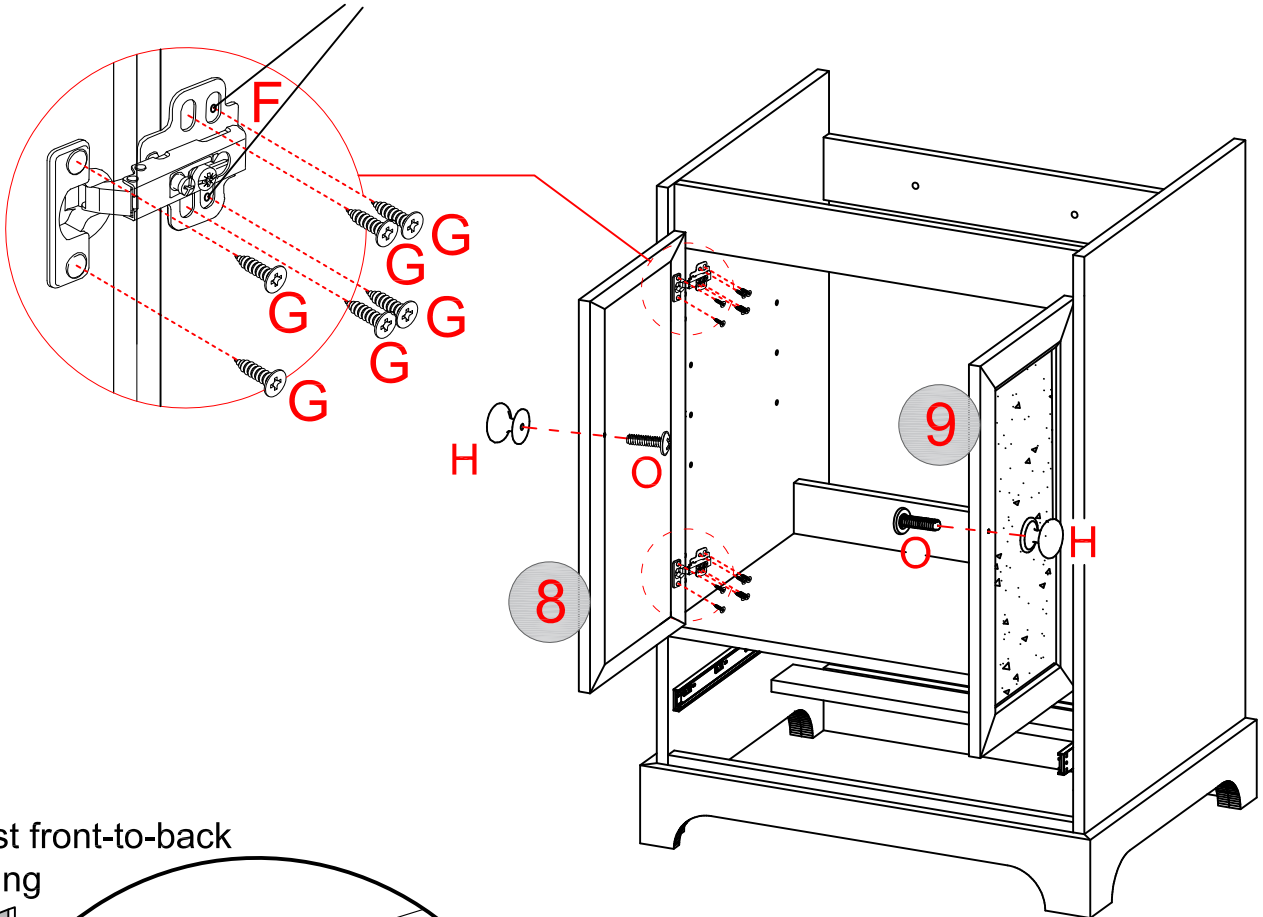

Adjust front-to-back spacing

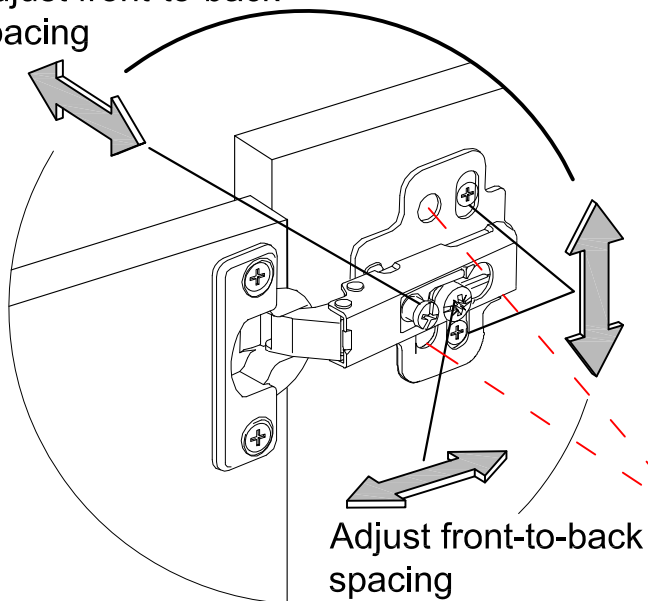

Adjust front-to-back spacing

Manual drilling is required to install this two screws

# STEP 6

**A** x8 pcs 

**J** x8 pcs 

**H** x2 pcs 

**I** x2 pcs   
4\*18

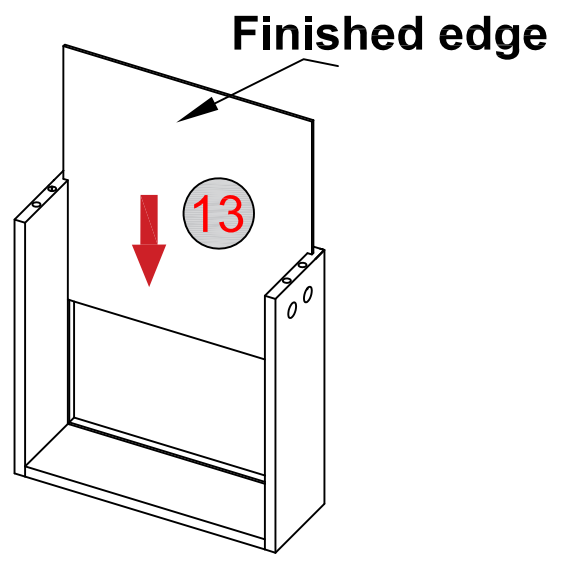
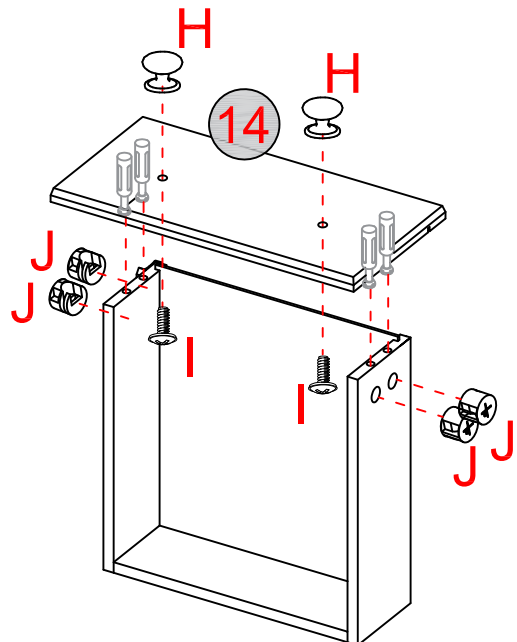
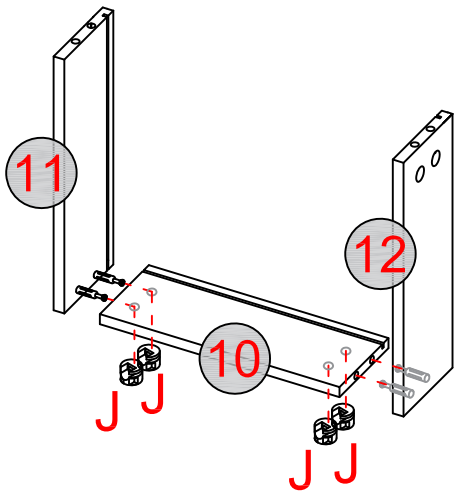

# STEP 7

**C2** x2 pcs 

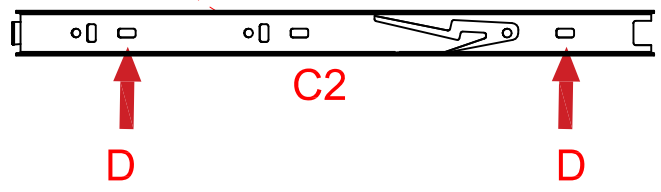
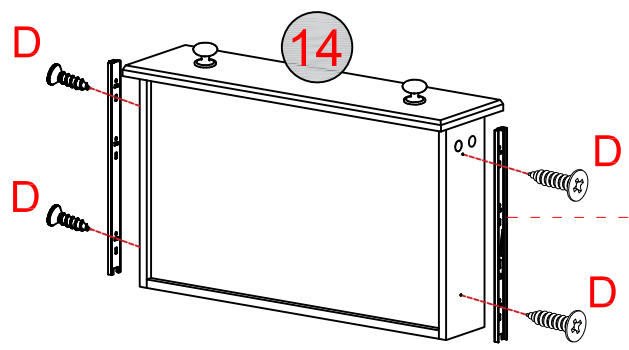

# STEP 8

**K** x4 pcs 

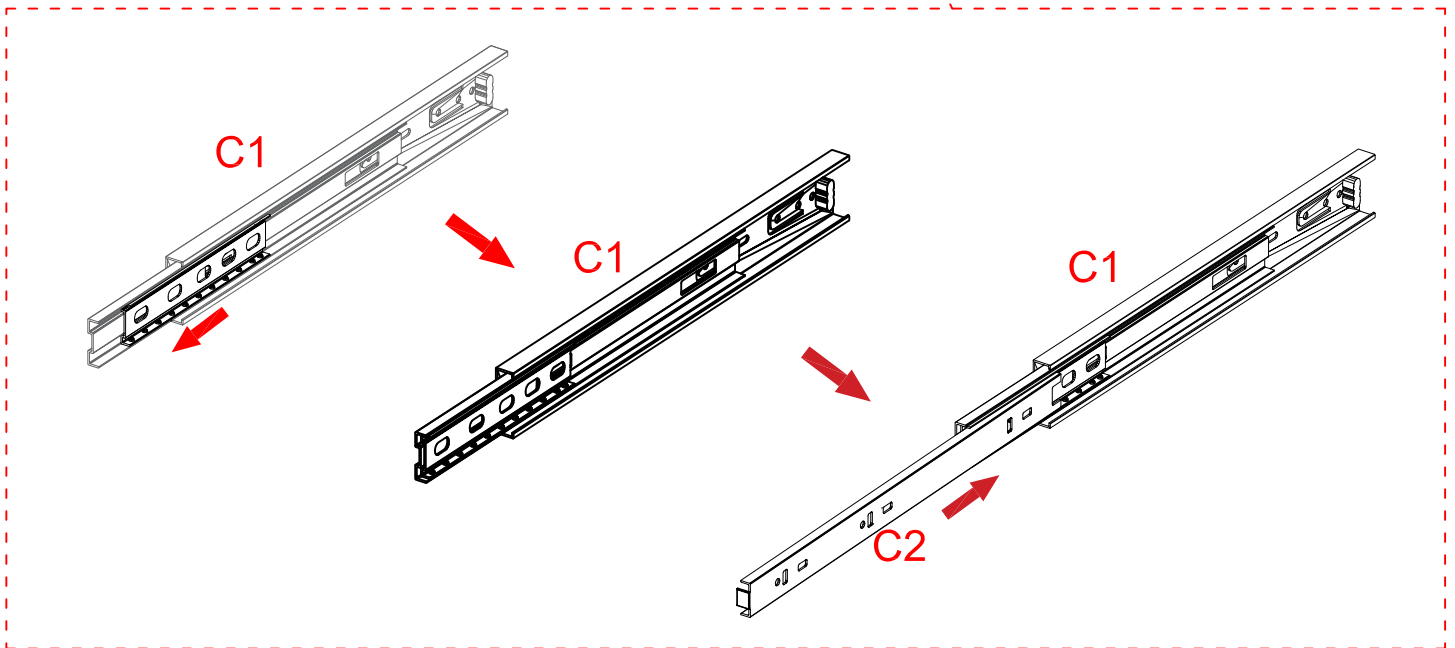
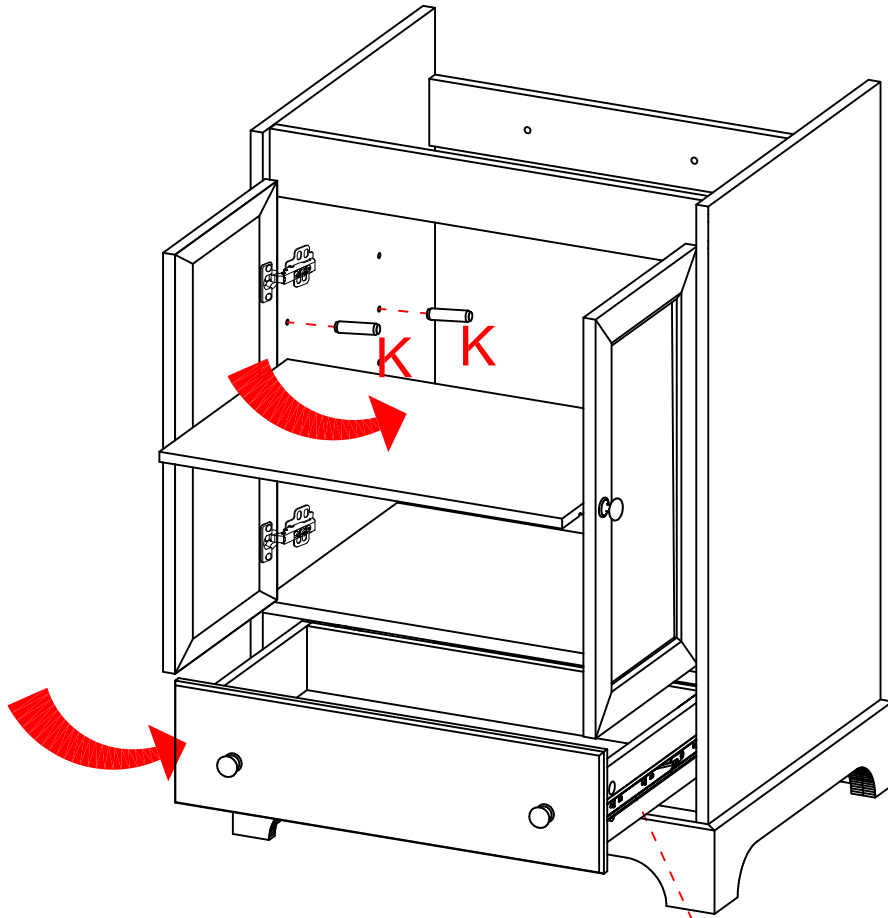

# STEP 9

**M** x2 pcs 

**N** x2 pcs 

