

# Desk with 2 drawers

Bureau avec 2 tiroirs

Schreibtisch mit 2 Schubladen

Scrivania con 2 cassetti

Escritorio con 2 cajones

서랍이 2개 달린 책상

引き出し2個付きデスク

侧框书桌

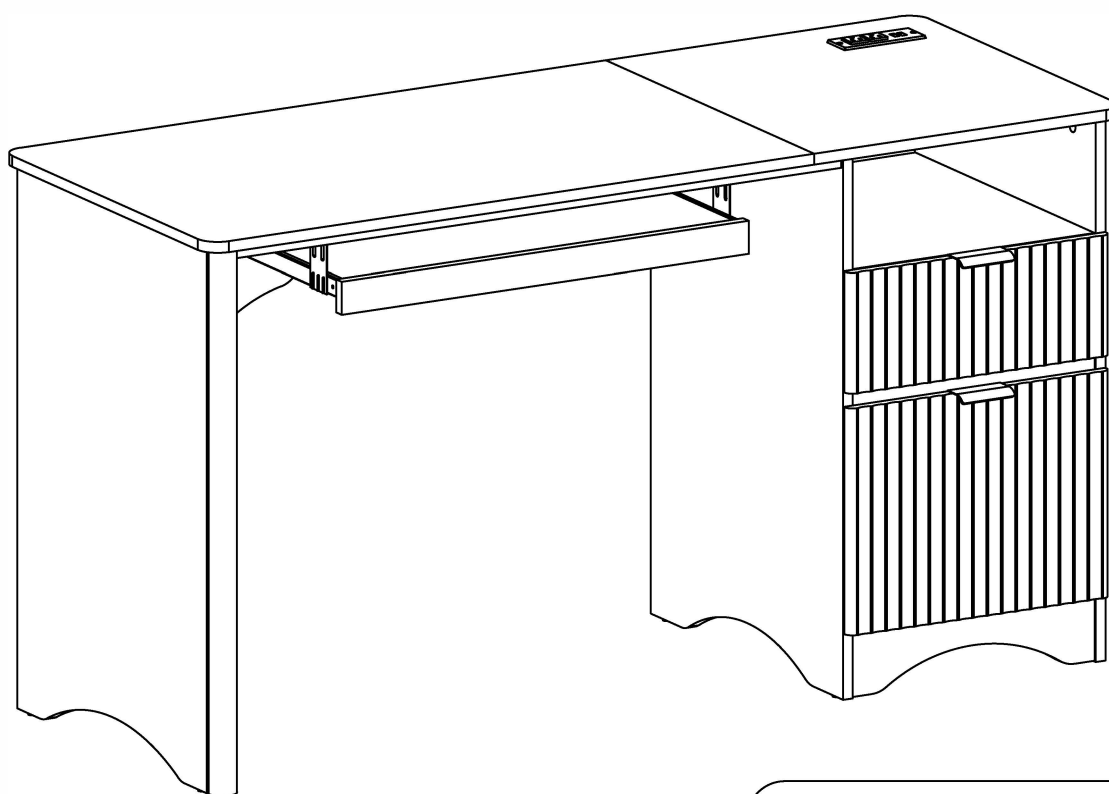

## ASSEMBLY INSTRUCTION

Montageanleitung

Instructions De Montage

Istruzioni Per L'assemblaggio

Instrucciones De Montaje

어셈블리 설명

組立説明書

安装说明书



## HELPFUL HINTS

### ⚠ BEFORE YOU START

- Inspect product packaging to ensure the appearance is good.
- Read the assembly instruction carefully and follow it step by step.
- To avoid any scratching, putting a soft blanket on the floor is suggested.
- Identify, sort and count all the parts with tags.
- Find out installation position according to the drawing and install it in correct steps.



#### OTHER

- People needed for assembly: 1-2.
- Estimated assembly time: 0.5-1h.

### ⚠ CAUTION

- Be cautious when using a power drill or power screwdriver.
- Please be aware to slow down and stop when screw is nearly tight.
- Do Not use any harsh chemicals or abrasive cleaners for this item.
- Push, pull or drag this item carefully.

## ASTUCES UTILES

### ⚠ AVANT DE COMMENCER

- Inspectez l'emballage du produit pour vous assurer que l'apparence est bonne.
- Lisez attentivement les instructions de montage et suivez-les étape par étape.
- Pour éviter toute rayure, posez une couverture douce sur le sol est suggéré.
- Identifiez, triez et comptez toutes les pièces avec des étiquettes.
- Trouver la position d'installation selon le dessin et l'installer dans les étapes correctes.



#### AUTRE

- Personnes nécessaires pour l'assemblage : 1-2.
- Temps de montage estimé : 0.5-1 h.

### ⚠ AVERTIR

- Soyez prudent lorsque vous utilisez une perceuse électrique ou un tournevis électrique.
- Veuillez être conscient de ralentir et d'arrêter lorsque la vis est presque serrée.
- N'utilisez pas de produits chimiques corrosifs ou de nettoyeurs abrasifs pour cet article.
- Poussez, tirez ou tirez cet article avec précaution.

## CONSEJOS ÚTILES

### ⚠ ANTES DE EMPEZAR

- Inspeccione el paquete del producto para asegurarse de que la apariencia es buena.
- Lea atentamente las instrucciones de montaje y sígalas paso a paso.
- Para evitar rayas, se sugiere poner una manta suave en el suelo.
- Identifique, clasifique y enumere todas las piezas con etiquetas.
- Averigüe la posición de instalación según el dibujo e instálela en los pasos correctos.



#### OTROS

- Personas necesarias para el montaje: 1-2.
- Tiempo de montaje estimado: 0.5-1 h.

### ⚠ PRECAUCIÓN

- Tenga cuidado al utilizar un taladro eléctrico o un destornillador eléctrico.
- Tenga en cuenta que debe hacerlo más despacio y detenerse cuando el tornillo esté casi apretado.
- No utilice productos químicos agresivos ni limpiadores abrasivos para este artículo.
- Empuje, tire o arrastre este elemento con cuidado.

## SUGGERIMENTI UTILI

### ⚠ PRIMA DI INIZIARE

- Controllare la confezione del prodotto per assicurarsi che sia in buono stato.
- Leggere con attenzione le istruzioni per l'assemblaggio e seguirle passo dopo passo.
- Per evitare graffi al pavimento, suggeriamo di stendervi una coperta morbida.
- Identificare, suddividere e contare tutte le parti con etichetta.
- Trovare la posizione adatta per il montaggio in base al disegno e montare lo scaffale seguendo correttamente i vari passaggi.



#### ALTRO

- Persone necessarie per l'assemblaggio: 1-2.
- Tempo di assemblaggio stimato: 0.5-1 ora.

### ⚠ ATTENZIONE

- Prestare molta attenzione quando si utilizza un trapano elettrico o un cacciavite elettrico.
- Rallentare con accortezza e fermarsi quando una vite è già sufficientemente serrata.
- Non utilizzare prodotti chimici aggressivi o detergenti abrasivi su questo articolo.
- Spingere, tirare o trascinare questo articolo con cautela.

## NÜTZLICHE HINWEISE

### ⚠ BEVOR SIE BEGINNEN

- Überprüfen Sie die Produktverpackung auf Schäden.
- Lesen Sie sich die Montageanleitung sorgfältig durch und befolgen Sie sie Schritt für Schritt.
- Um etwaiges Zerkratzen zu vermeiden, wird das Auslegen einer weichen Decke auf dem Boden empfohlen.
- Identifizieren, sortieren und zählen Sie alle Teile mit Tags nach.
- Identifizieren Sie die Montageposition gemäß der Zeichnung und bauen Sie das Regal den richtigen Schritten entsprechend auf.

**SONSTIGES**

- Für den Zusammenbau erforderliche Anzahl an Menschen: 1-2.
- Ungefähre Montagedauer: 0.5-1 h.

### ⚠ VORSICHT

- Seien Sie bei der Verwendung einer Bohrmaschine oder eines Akkuschraubers vorsichtig.
- Bitte vergessen Sie nicht darauf, langsamer zu werden und zu stoppen, sobald die Schraube fast festgezogen ist.
- Verwenden Sie keinerlei aggressive Chemikalien oder scheuernden Reinigungsmittel für dieses Produkt.
- Schieben oder ziehen Sie dieses Produkt vorsichtig.

## 유용한 힌트

### ⚠ 시작하기 전에

- 제품 포장 검사, 확보외관이 좋다.
- 어셈블리 지침 자세히 보기한 걸음 한 걸음 그것을 따르다.
- 굵기지 않도록 바닥에 부드러운 담요를 놓는 것이 좋습니다.
- 모든 부품을 라벨로 식별, 분류 및 계산합니다.
- 도면에 따라 설치 위치를 찾아 올바른 단계에 따라 설치합니다.

**기타**

- 조립에 필요한 인원: 1-2명.
- 예상 조립 시간: 0.5-1h.

### ⚠ 안전에 주의하다:

- 전기 드릴이나 전기 드라이버를 사용할 때는 조심해야 한다.
- 나사가 거의 조이면 속도를 줄이고 멈추십시오.
- 자극성 화학물질이나 연마성 세정제는 이 품목에 사용하지 마십시오.
- 이 항목을 조심스럽게 밀거나 당기거나 드래그합니다.

## 役に立つヒント

### ⚠ 組立の場所を確保し、順番通りに組み立てる

- 組立場所 (充分広くて平たい場 v 所) を確保してください。
- 床や壁、商品を傷つけないように、商品の下に厚めの布や段ボールなどを敷いてください。
- 組立の順番を守らないと、組立できなくなったり、商品を傷つけたりします。

**その他**

- 組み立てに必要な人: 1-2.
- 組立時間: 約0.5 ~ 1時間.

### ⚠ 部品を確認する

- ネジ類などの部品番号、形状を説明書の部品一覧で確認してください。
- 部品をなくさないように纏めて置いてください。
- 部品を取り出すときに使う分だけ取り出してください。

## 温馨提示

### ⚠ 安装前注意事项

- 检查产品包装, 确保外观良好.
- 仔细阅读安装说明, 按步骤操作.
- 为了避免刮伤, 建议在地板上放一条柔软的毯子.
- 标识、分类和清点所有部件.
- 根据图形找到安装孔位, 按正确步骤安装.

**其他:**

- 组装所需人员: 1-2人.
- 预计组装时间: 0.5-1小时.

### ⚠ 注意:

- 小心使用电钻或电动螺丝刀.
- 当螺丝快要拧紧时, 请注意减速.
- 不要使用任何刺激性化学物质或擦洗剂.
- 当推、拉或拖动产品时, 注意小心谨慎, 防止损坏.

UNIT:INCH/CM/厘米

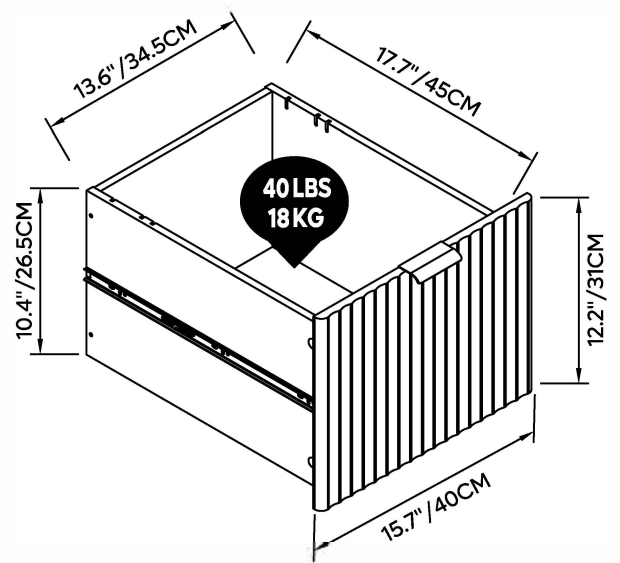
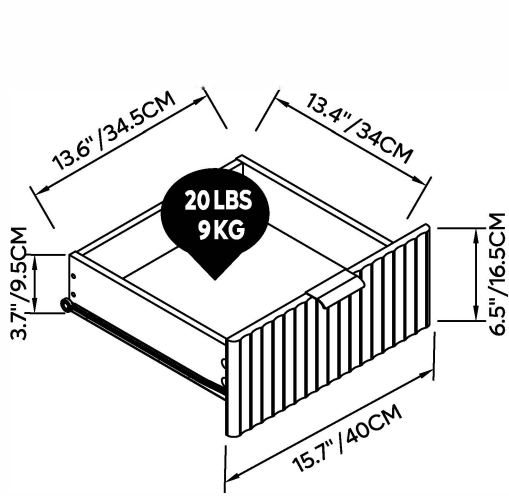
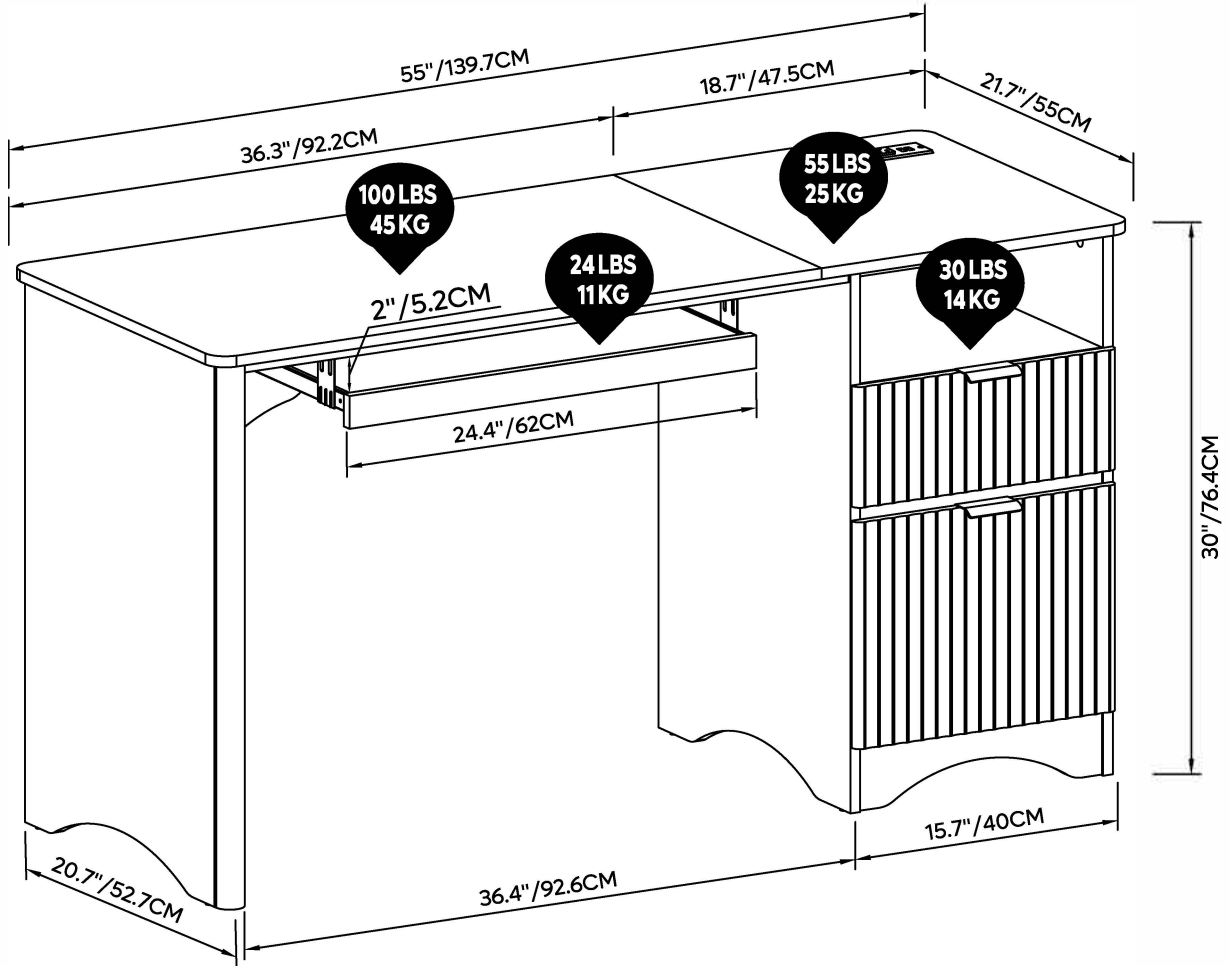

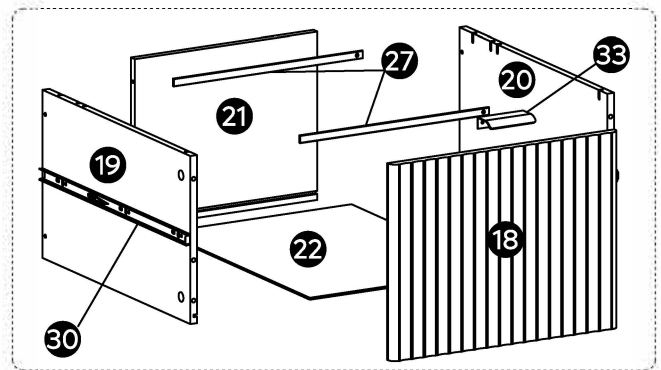
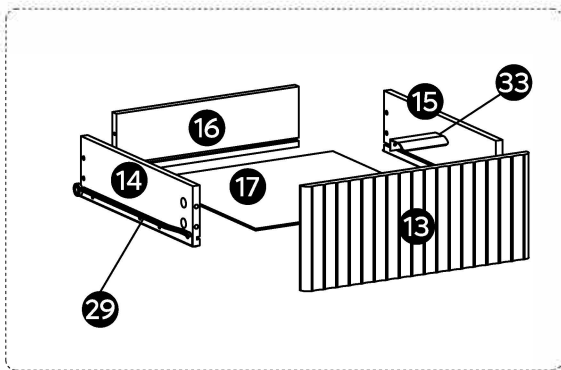
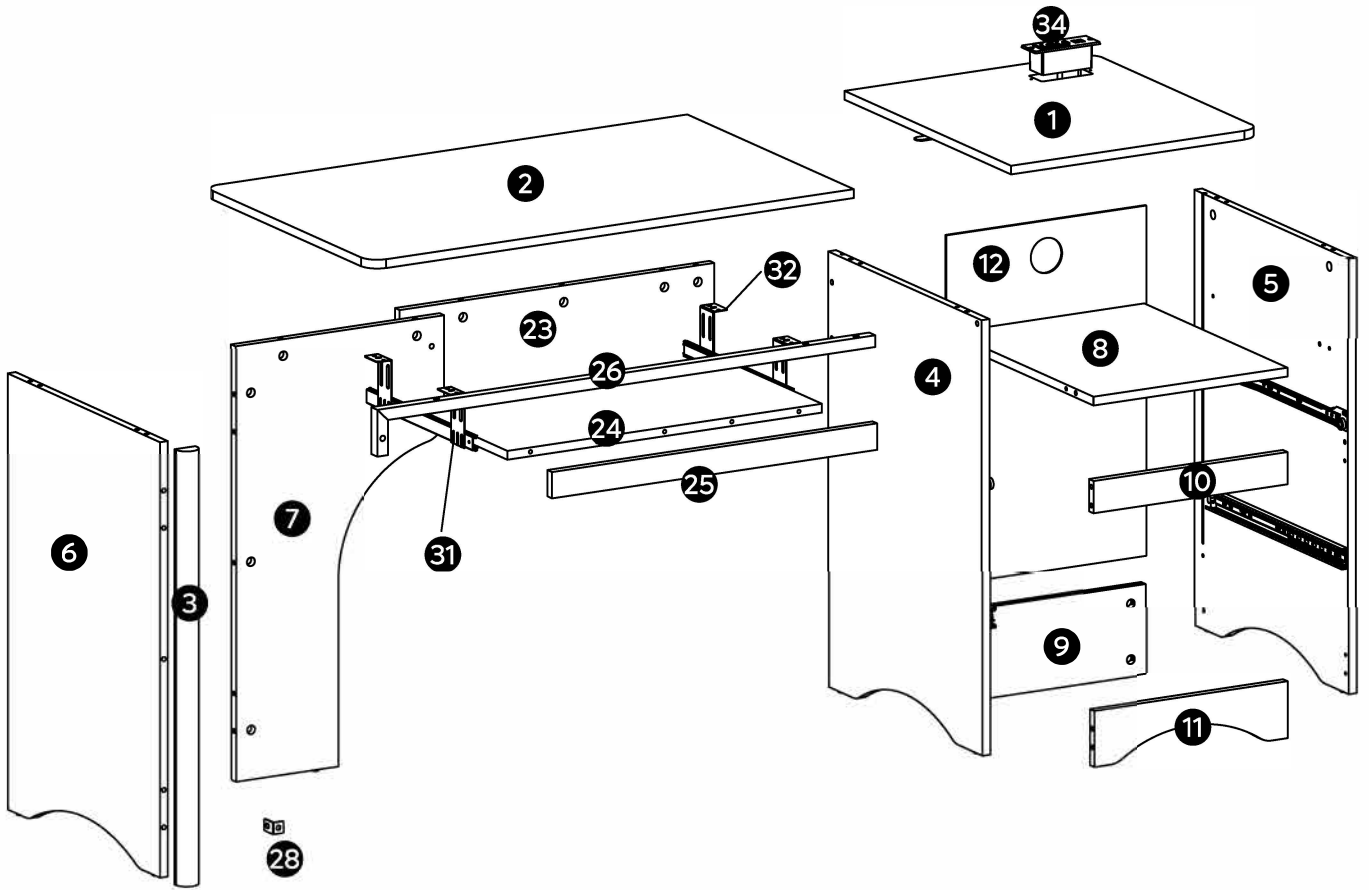

# PART LIST

STÜCKLISTE  
LISTE DES PIÈCES  
ELENCO DEI PEZZI

LISTA DE PIEZAS  
부품 목록  
部品の確認/部件清單

1

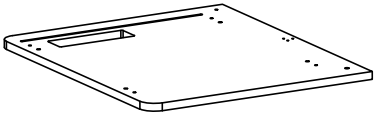

X1

2

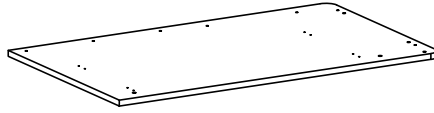

X1

3



X1

4

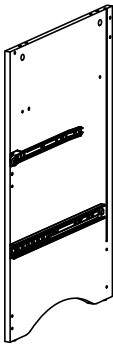

X1

5

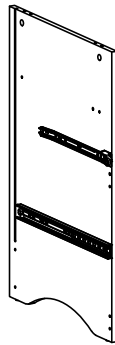

X1

6

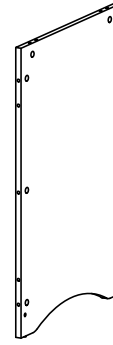

X1

7

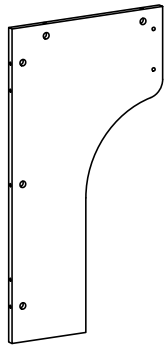

X1

8

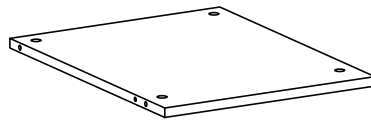

X1

9



X1

10



X1

11

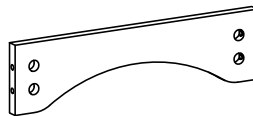

X1

12

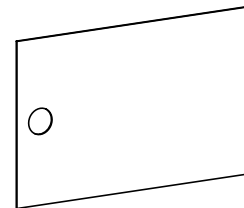

X1

13

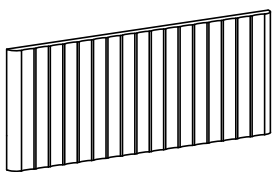

X1

14

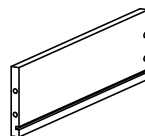

X1

15

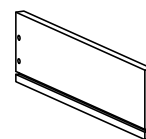

X1

# PART LIST

STÜCKLISTE  
LISTE DES PIÈCES  
ELENCO DEI PEZZI

LISTA DE PIEZAS  
부품 목록  
部品の確認/部件清單

16



X1

17

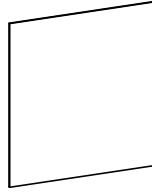

X1

18

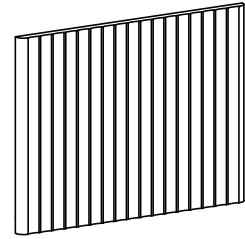

X1

19

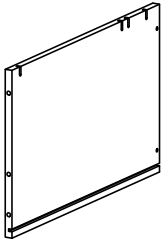

X1

20

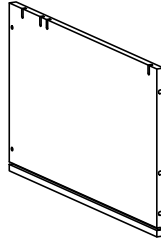

X1

21

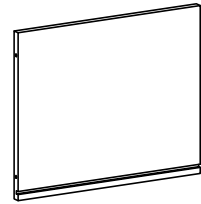

X1

22

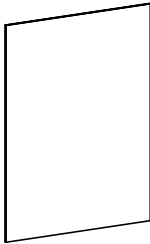

X1

23

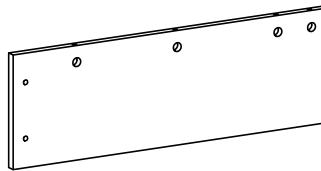

X1

24

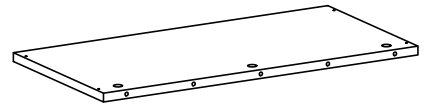

X1

25

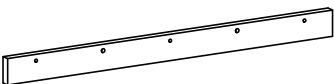

X1

26



X1

27



X2

28

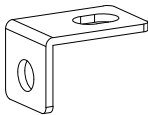

X1

29

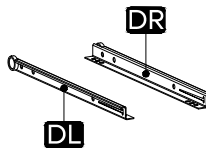

X1

30



X2

31

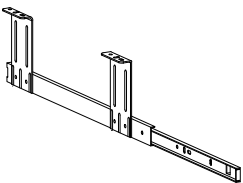

X1

32

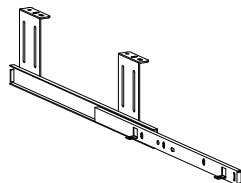

X1

33

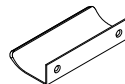

X2

34

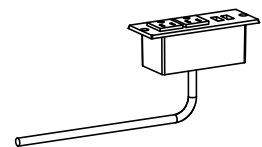









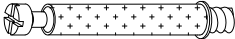

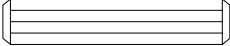
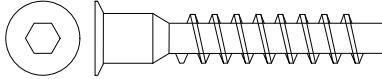
X1

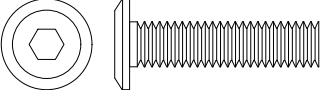
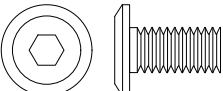
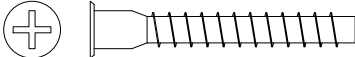
# ACCESSORY LIST

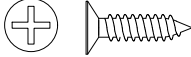
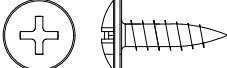
ZUBEHÖRLISTE  
LISTE DES ACCESSOIRES  
ELENCO DEGLI ACCESSORI

LISTA DE ACCESORIOS  
부품 목록  
付属品部品の確認/配件清單

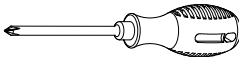
<b>A</b>	ST6x35mm	43+3	
<b>B</b>	Ø15mm	43+3	
<b>C</b>	Ø6x30mm	18+2	
<b>D</b>	ST7x38mm	2	
<b>E</b>	M6x28mm	5+1	
<b>F</b>	M6x25mm	2	
<b>G</b>	M6x12mm	2	
<b>H</b>	ST5x35mm	8+1	
<b>I</b>	ST3.5x12mm	14+1	
<b>J</b>	ST4x14mm	7+1	
<b>K</b>	ST4x14mm	12+1	
<b>L</b>		4+1	
<b>M</b>		1	
	M4	1	
		1	

# Detailed Installation for Accessory A B

Installation détaillée pour l'accessoire A B  
 Detaillierte Installation des Zubehörs A B  
 Installazione dettagliata per l'accessorio A B  
 Instalación detallada del accesorio A B  
 액세서리 A 및 액세서리 B의 상세 설치  
 カムロック取り付け方  
 配件A、B详细安装

1

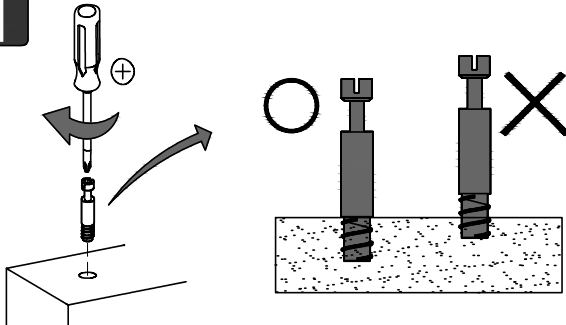

Screw cam dowel on the panel.  
 Vissez la goupille de came au panneau.  
 Nockendübel auf die Platte schrauben.  
 Avvitare il tassello a camme sul pannello.  
 tornillo de pasador de leva en el panel.  
 캠 핀을 패널에 조입니다.  
 カムロックネジを部品に取り付ける。  
 螺杆用十字螺丝刀装入对应的预留孔内

Place another panel via the dowel.  
 Placez un autre panneau par le goujon.  
 Setzen Sie eine weitere Platte über den Dübel ein.  
 Posizionare un altro pannello tramite il tassello.  
 Coloque otro panel a través del pasador.  
 핀을 통해 다른 패널을 배치합니다.  
 カムロックネジをカムロック穴に差し込む。  
 螺杆插入对应孔位，将两块板材对接起来。

2

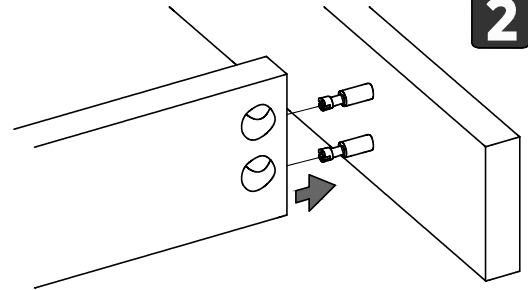

3

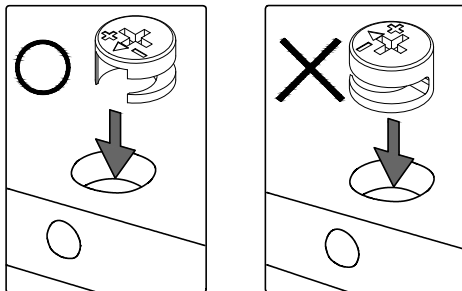

Pay attention to the direction of cam lock when putting it into hole.  
 Faites attention à la direction du verrou à came en entrant dans le trou.  
 Achten Sie auf die Richtung des Nockenschlosses, wenn Sie es in das Loch stecken.  
 Fare attenzione alla direzione della serratura a camme quando lo si inserisce nel foro.  
 Preste atención a la dirección de la leva de fijación al insertarla en el orificio.  
 캠 자물쇠를 구멍에 넣을 때 캠 자물쇠의 방향에 주의하십시오.  
 カムロックネジの方向にカムロックの穴の穴の向きを合わせ取り付け。  
 装入锁扣圆盘，注意锁扣圆盘的方向；

Tighten up cam lock clockwise until it stops.  
 Serrez le verrou à came dans le sens des aiguilles d'une montre jusqu'à ce qu'il s'arrête.  
 Ziehen Sie die Nockenverriegelung im Uhrzeigersinn bis zum Anschlag an.  
 Stringere la serratura a camme in senso orario fino all'arresto.  
 Apriete la leva de fijación en sentido horario hasta el tope.  
 타이밍에 맞춰 캠 자물쇠가 멈출 때까지 조입니다.  
 カムロックをドライバーで締め固定する。  
 顺时针旋转锁扣圆盘并锁紧。

4

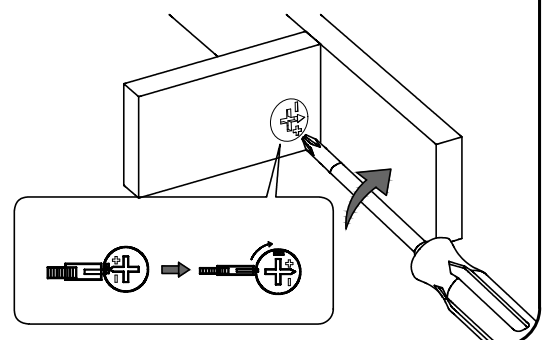

1

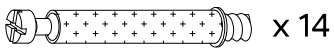
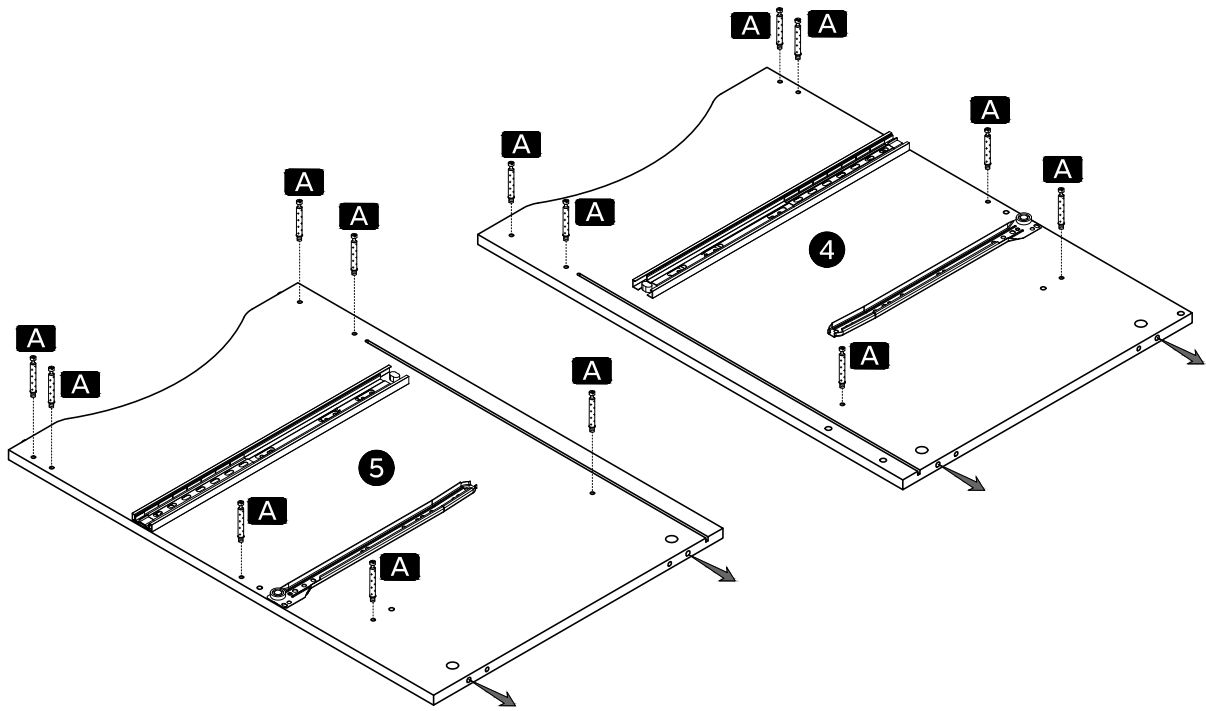

A ST6x35mm

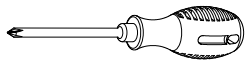

2

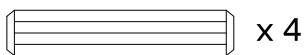
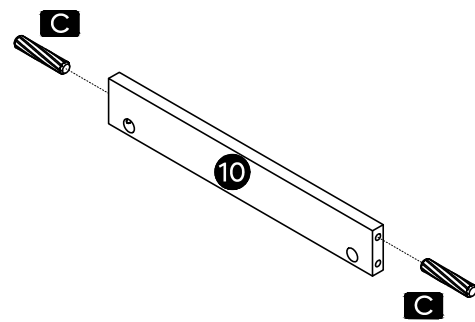
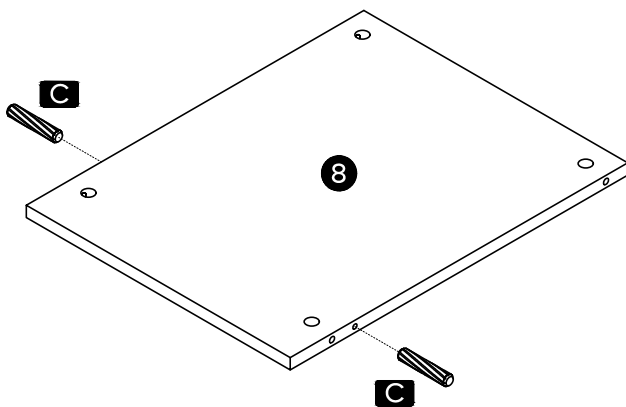

C Ø6x30mm

### 3

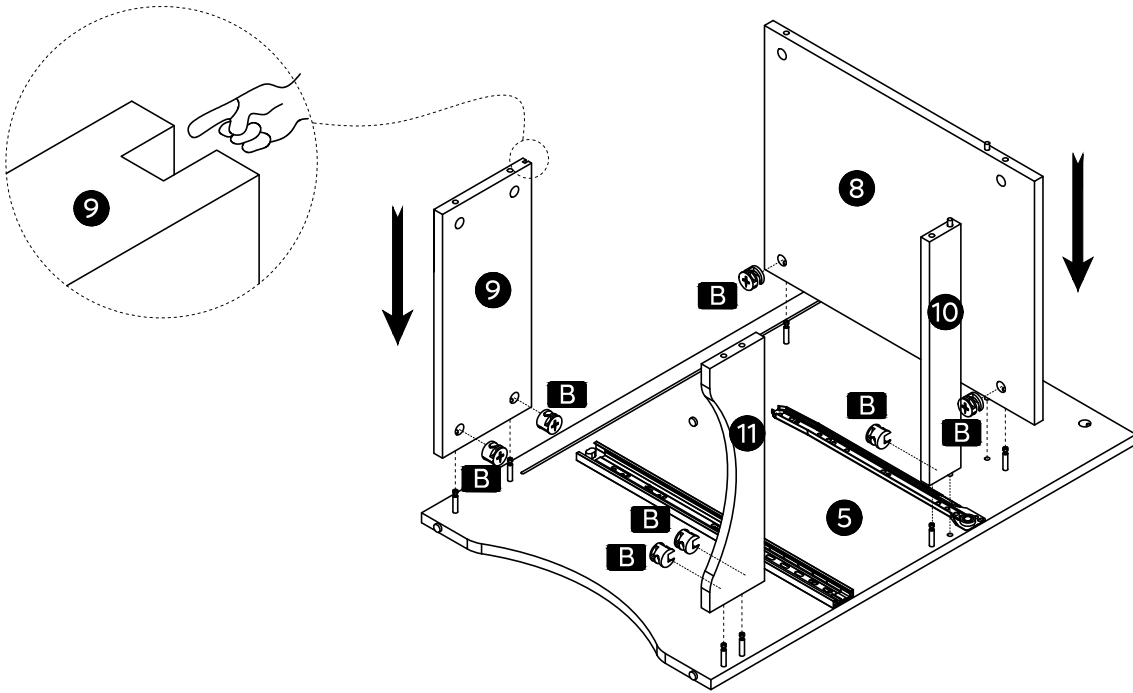

x 7

**B** Ø15mm

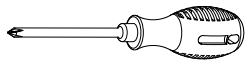

### 4

- ※ Two persons are needed.
- ※ Deux personnes sont nécessaires.
- ※ Zwei Personen sind erforderlich.
- ※ Sono necessarie due persone.
- ※ Se necesitan dos personas.
- ※ 두 사람이 필요합니다.
- ※ 必ず2人で作業してください。
- ※ 需要2个人协助。

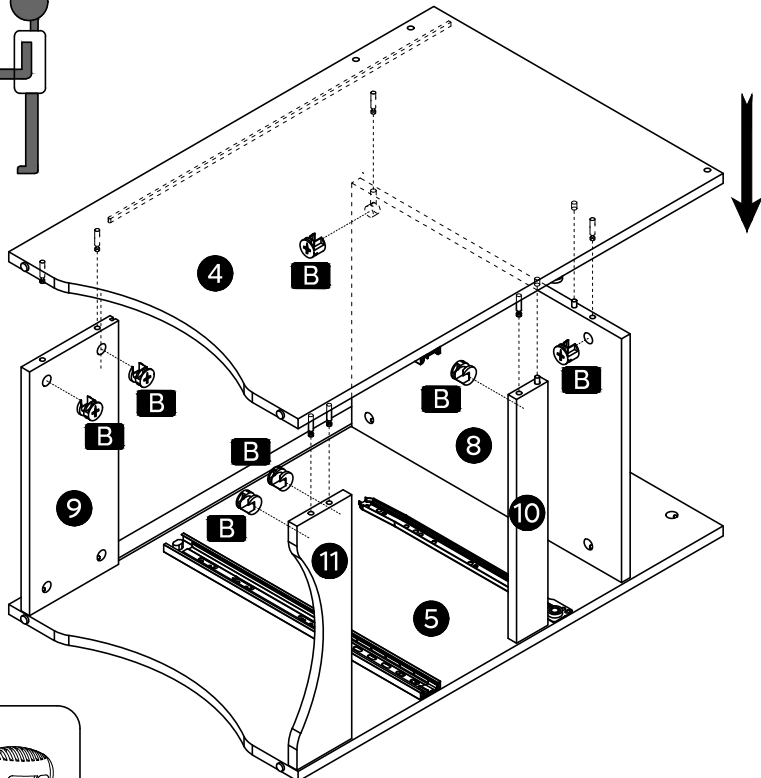
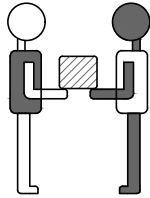

x 7

**B** Ø15mm

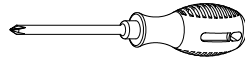

# 5

- ※ Turn over.
- ※ Retournement.
- ※ Umdrehen.
- ※ Capovolgere.
- ※ Girar.
- ※ 뒤집어.
- ※ 反転する。
- ※ 翻转过来。

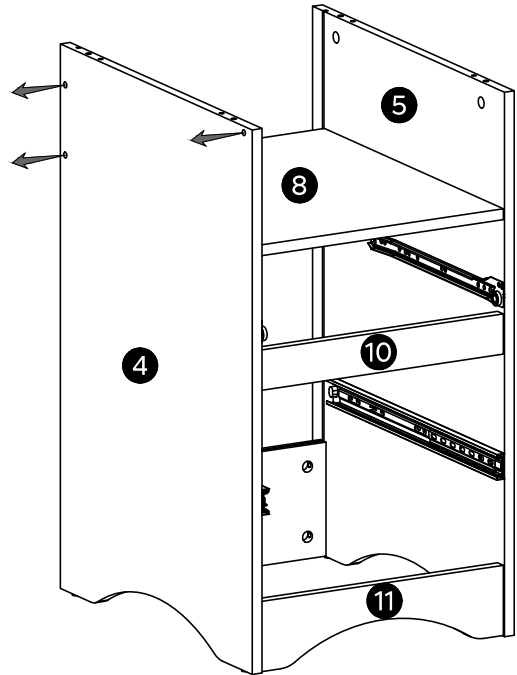

# 6

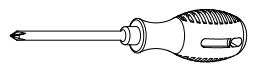
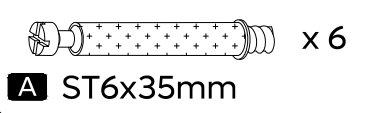
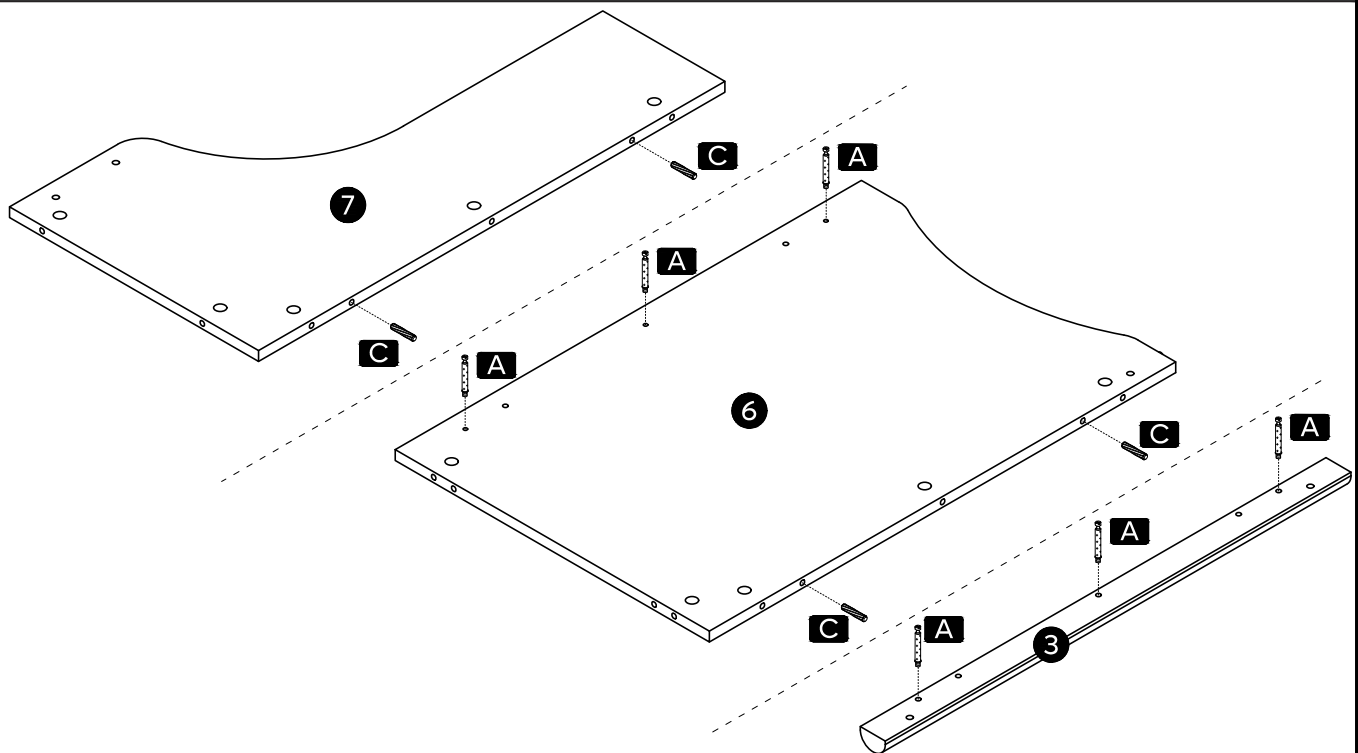

7

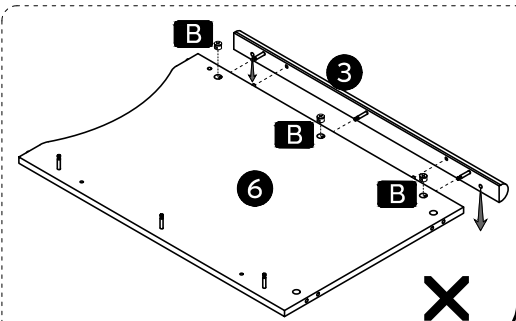
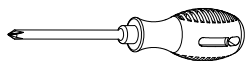
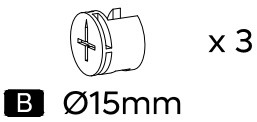
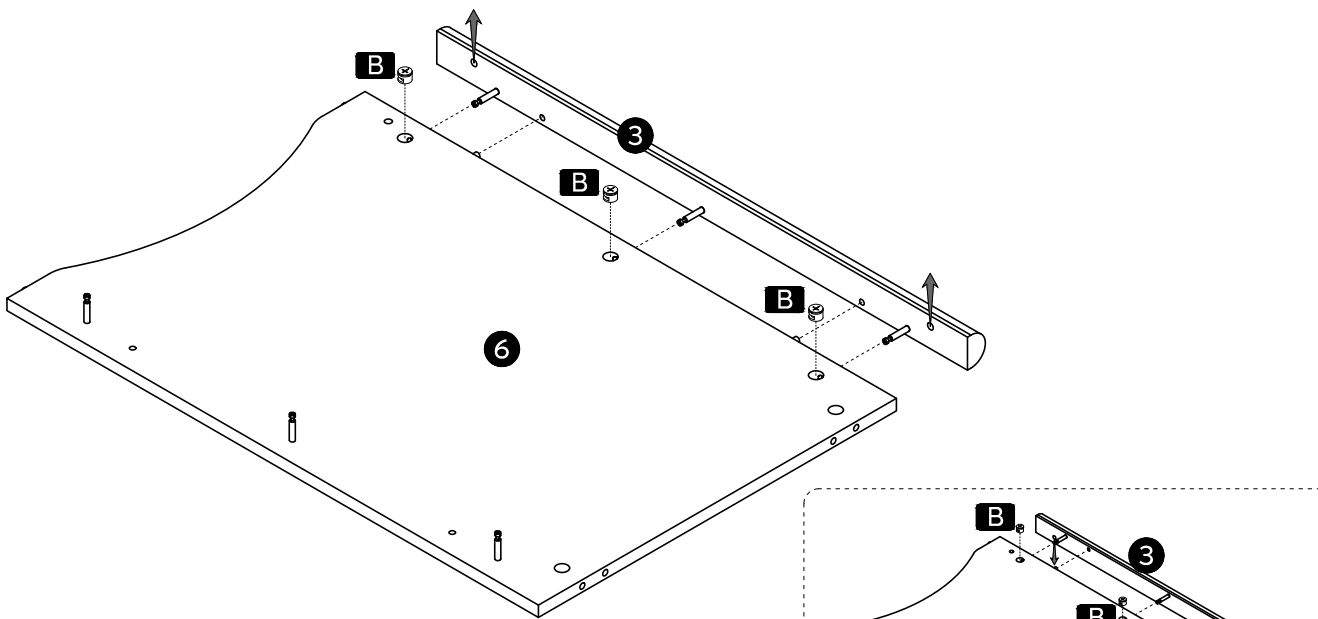

8

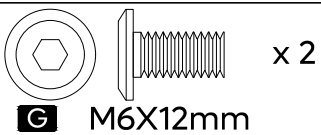
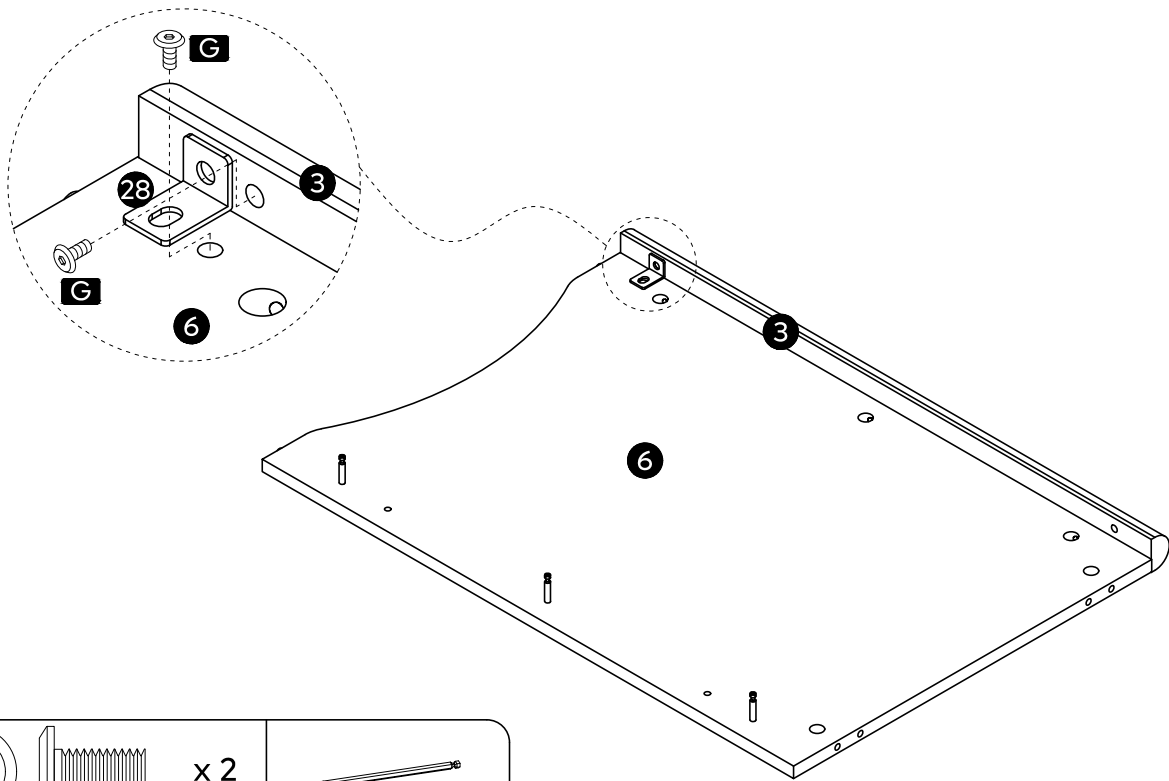

9

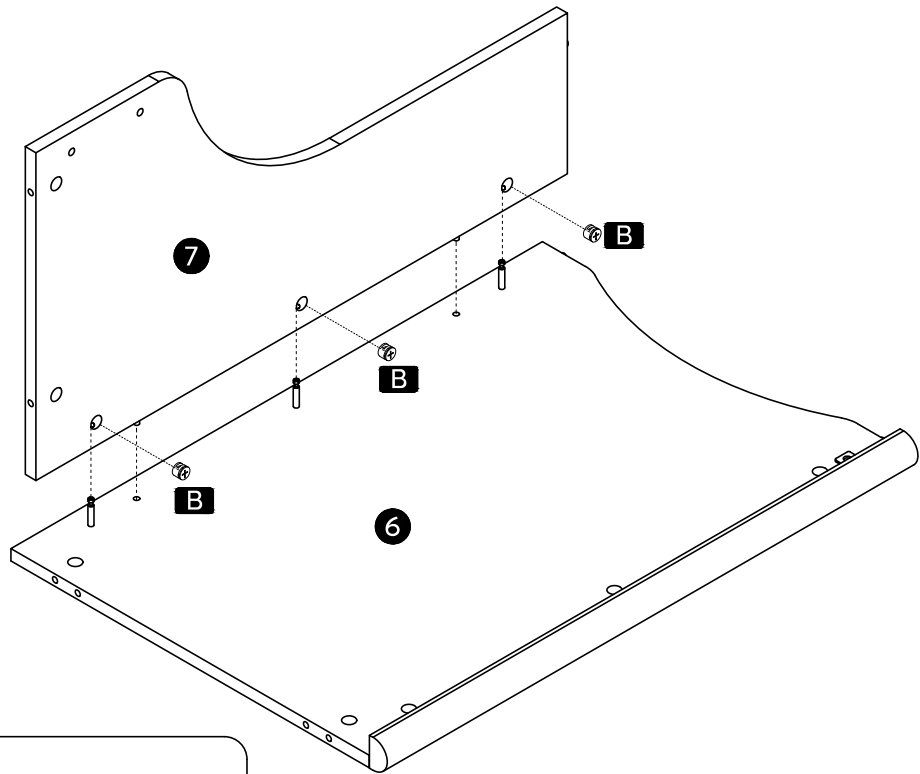

x 3

**B** Ø15mm

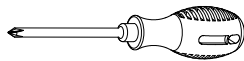

10

- ※ Two persons are needed.
- ※ Deux personnes sont nécessaires.
- ※ Zwei Personen sind erforderlich.
- ※ Sono necessarie due persone.
- ※ Se necesitan dos personas.
- ※ 두 사람이 필요합니다.
- ※ 必ず2人で作業してください。
- ※ 需要2个人协助。

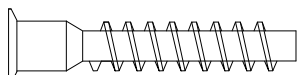
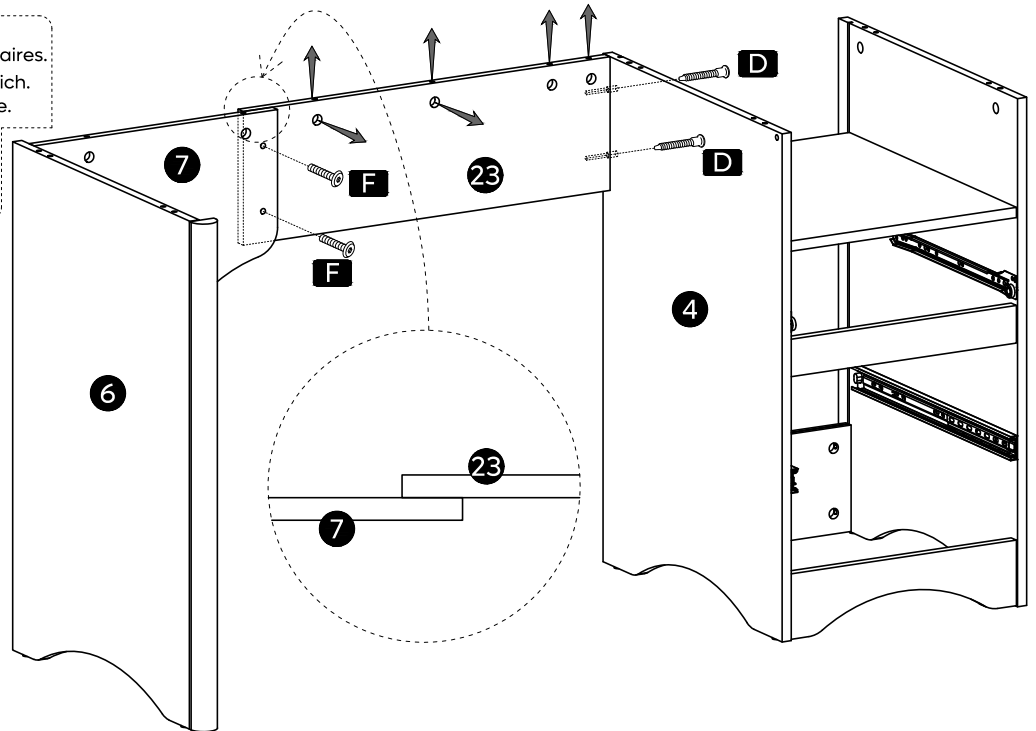
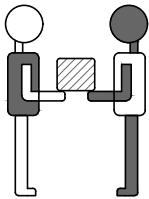

x 2

**D** ST7x38mm

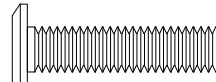

x 2

**F** M6x25mm



11

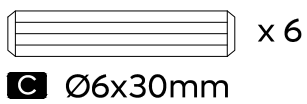
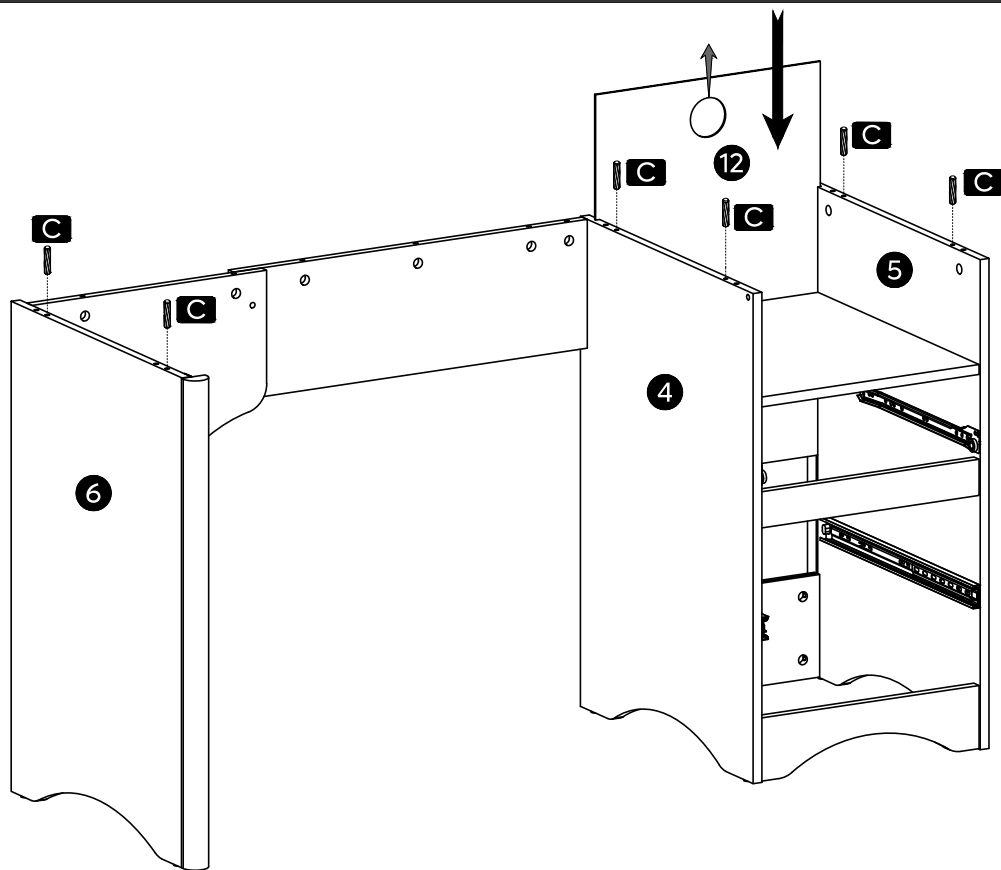

12

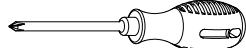
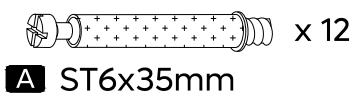
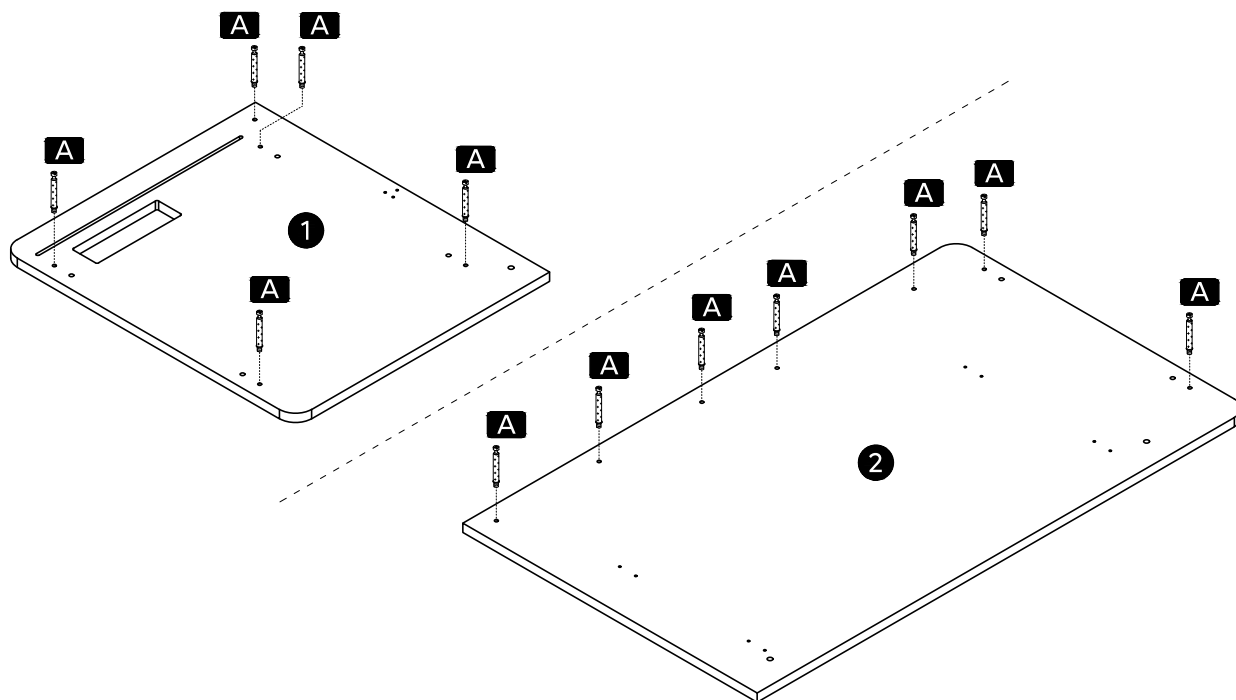

# 13

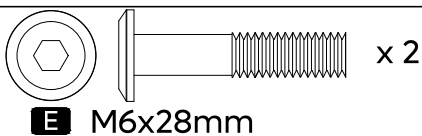
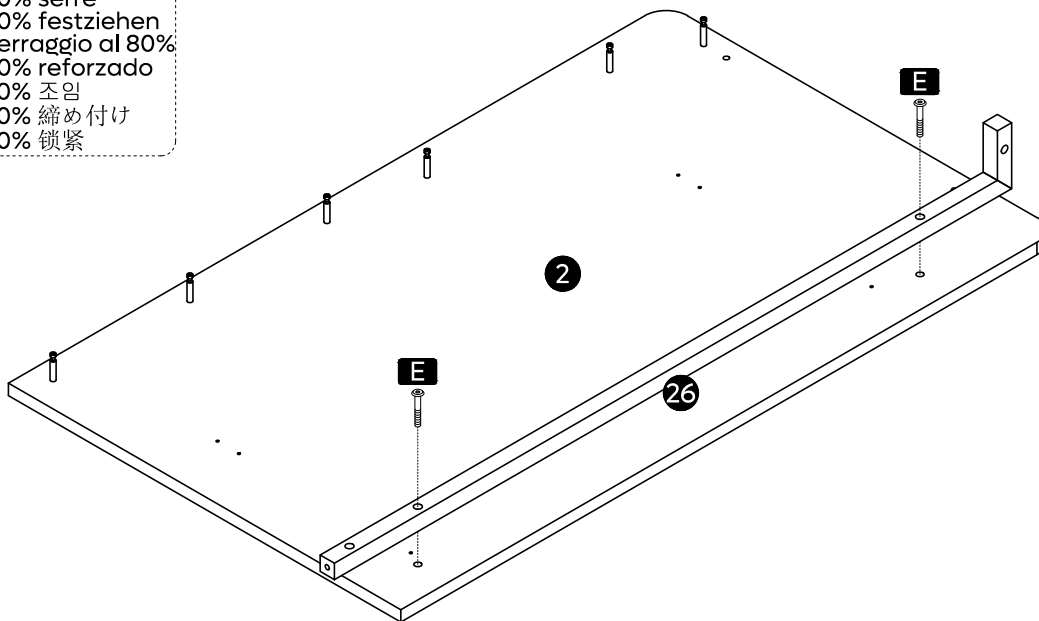

 80% tighten  
 80% serré  
 80% festziehen  
 Serraggio al 80%  
 80% reforzado  
 80% 조임  
 80% 締め付け  
 80% 锁紧

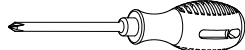
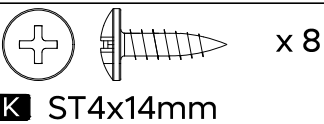
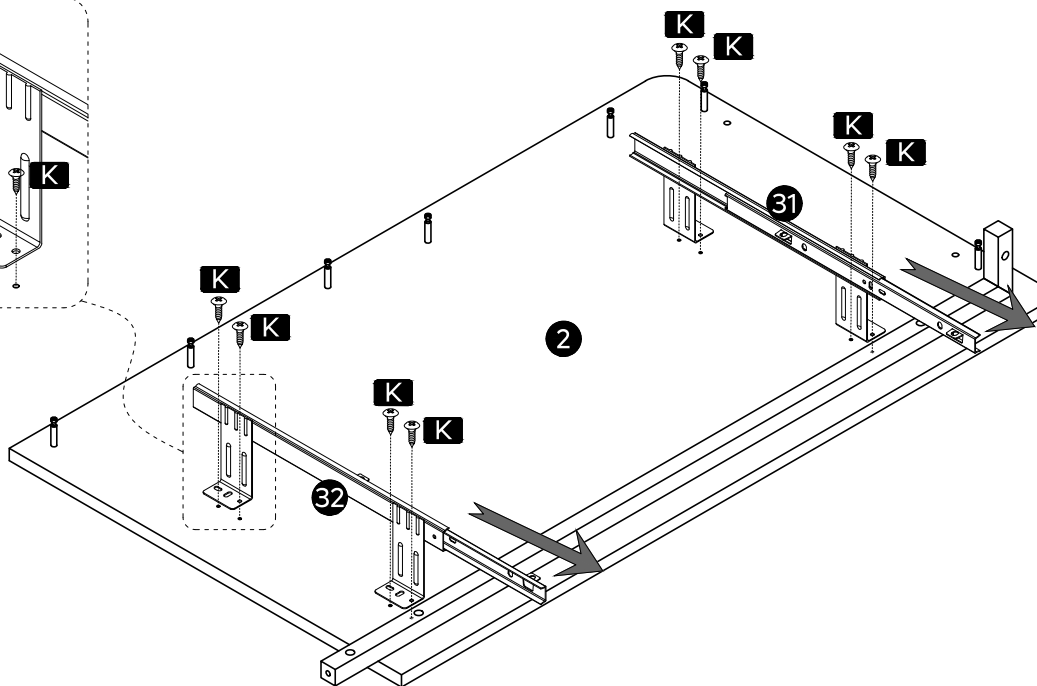
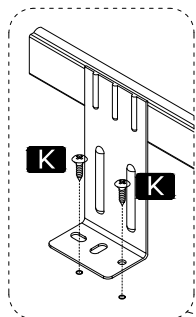

# 14

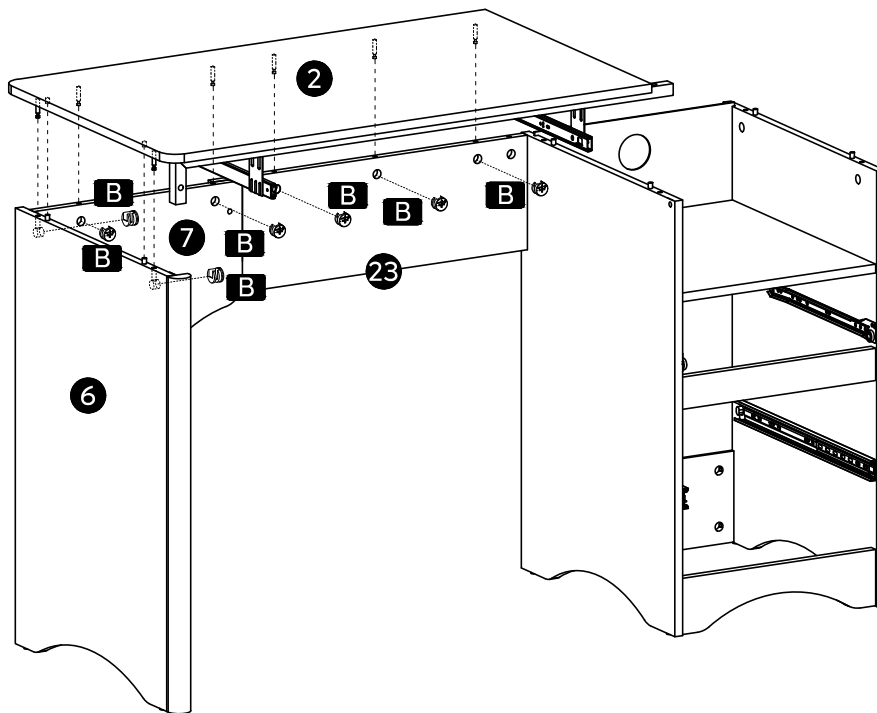

15



x 7

**B** Ø15mm

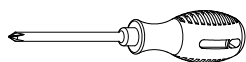

16

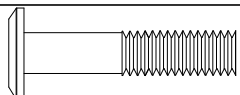
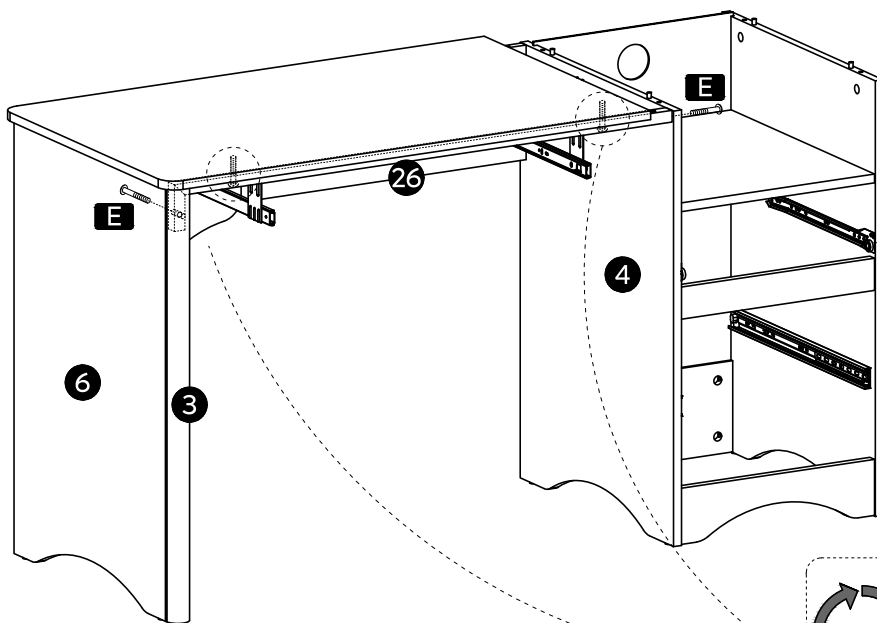

x 2

**E** M6x28mm



100% tighten  
 100% serré  
 100% festziehen  
 Serraggio al 100%  
 100% reforzado  
 100% 조임  
 100% 締め付け  
 100% 锁紧

17

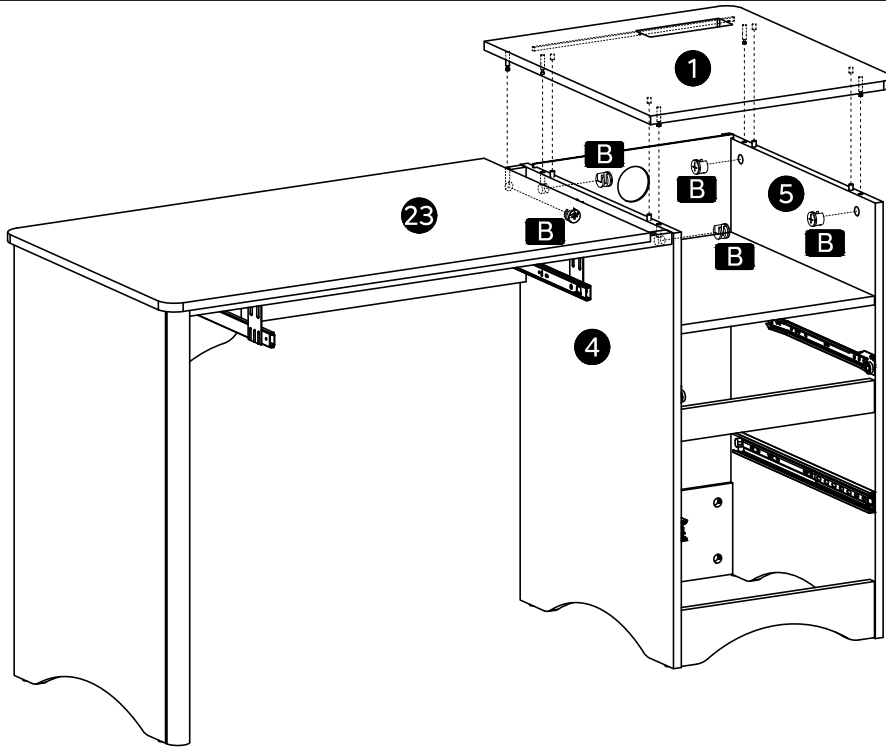

x 5

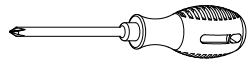

**B** Ø15mm

18

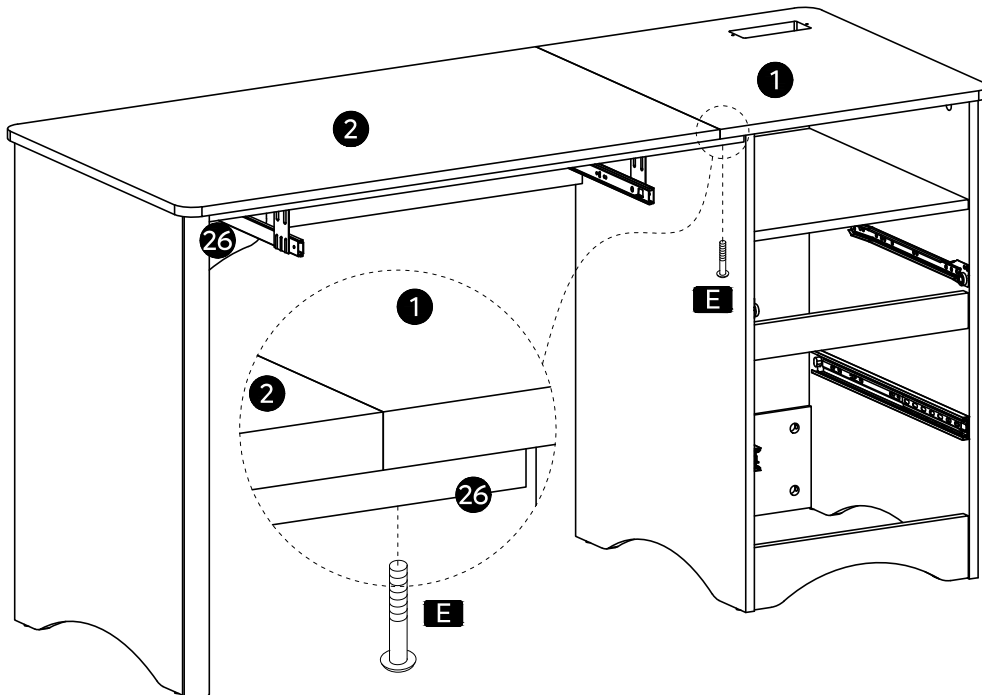

**E** M6x28mm

x 1



18

# 19

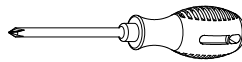
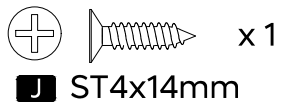
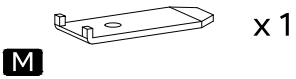
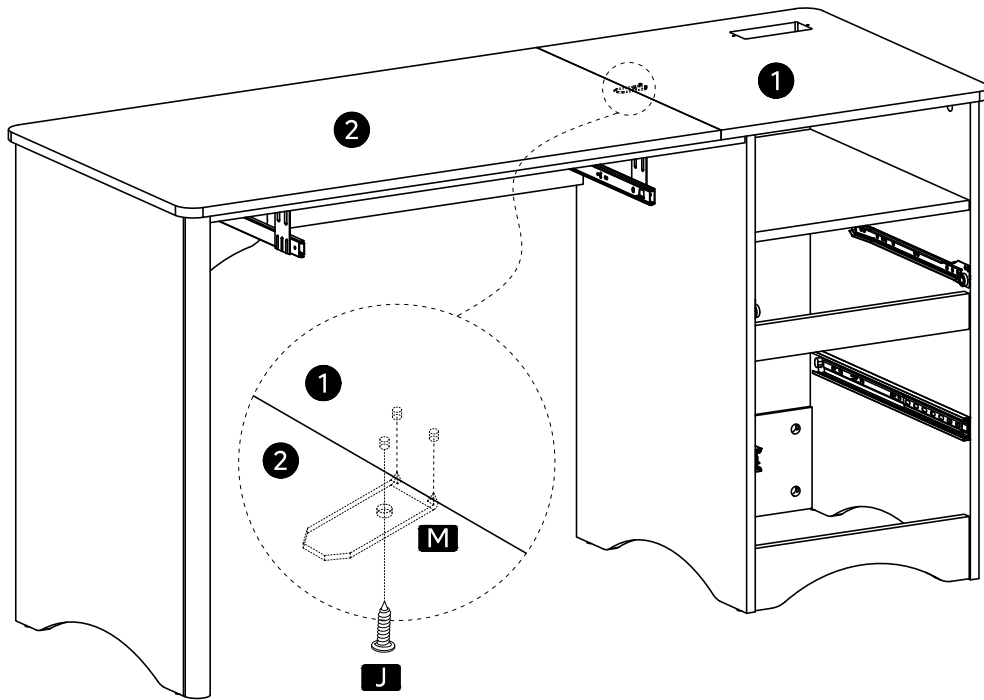

# 20

- ※ Back view.
- ※ Vue arrière.
- ※ Rückansicht.
- ※ Vista posteriore.
- ※ Vista trasera.
- ※ 후면 뷰.
- ※ バックビュー。
- ※ 背视图。

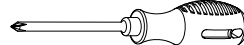
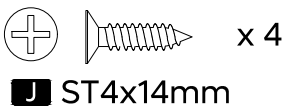
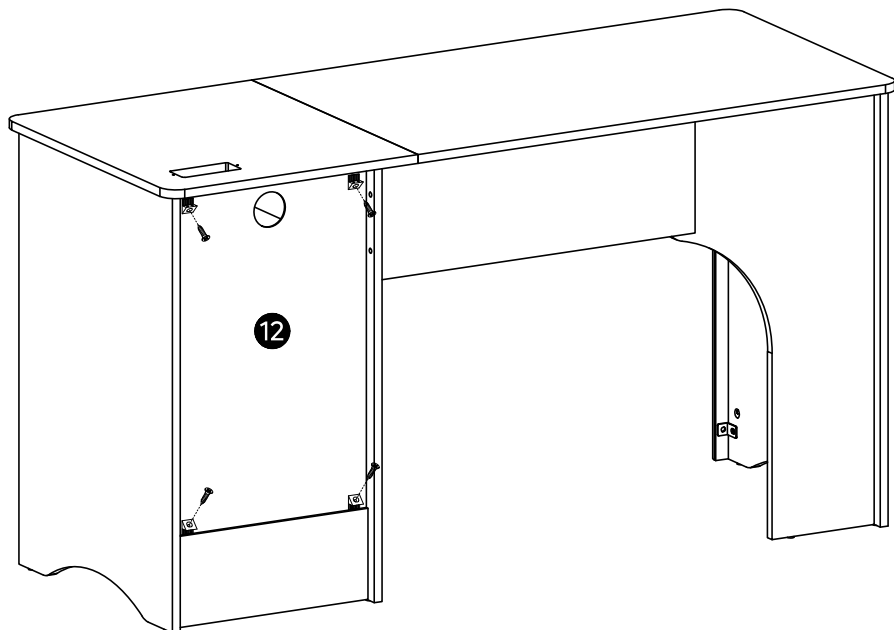
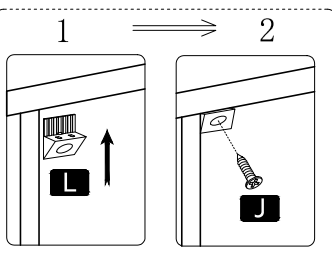

21

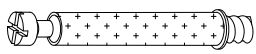
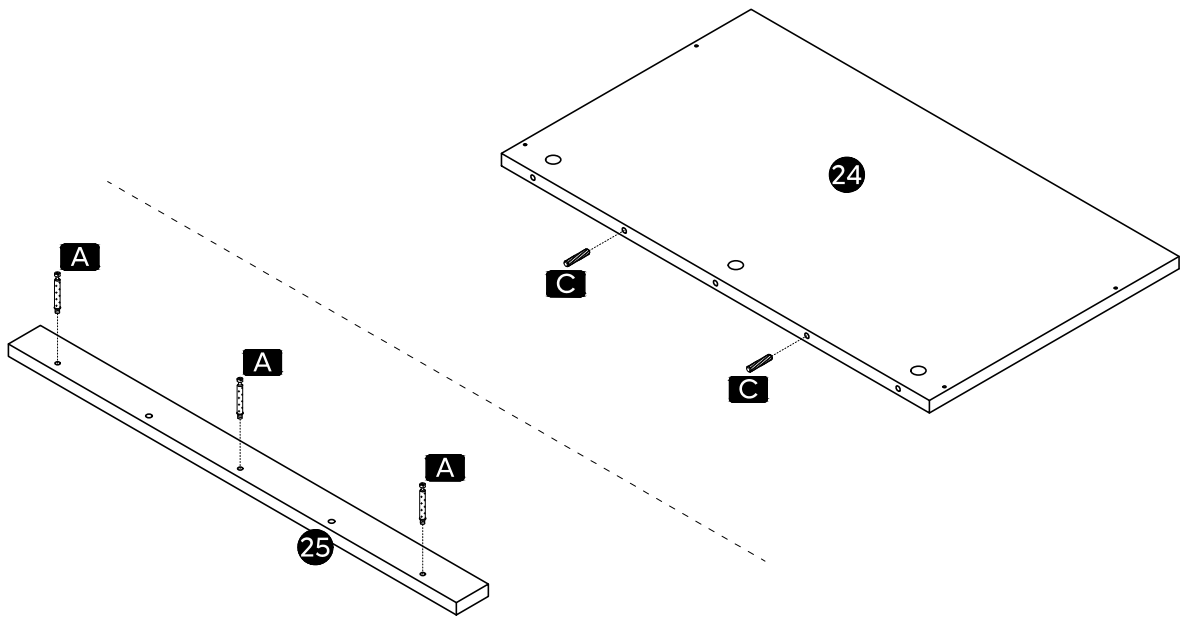

x 3

**A** ST6x35mm

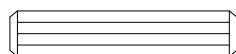

x 2

**C** Ø6x30mm

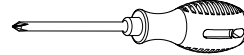

22

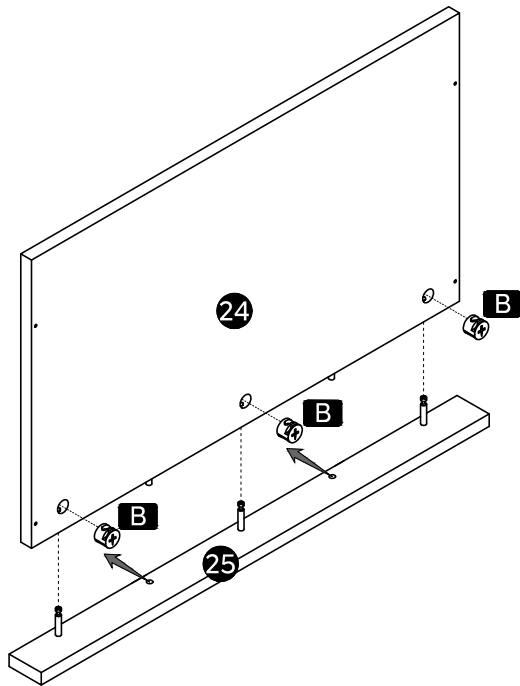

x 3

**B** Ø15mm

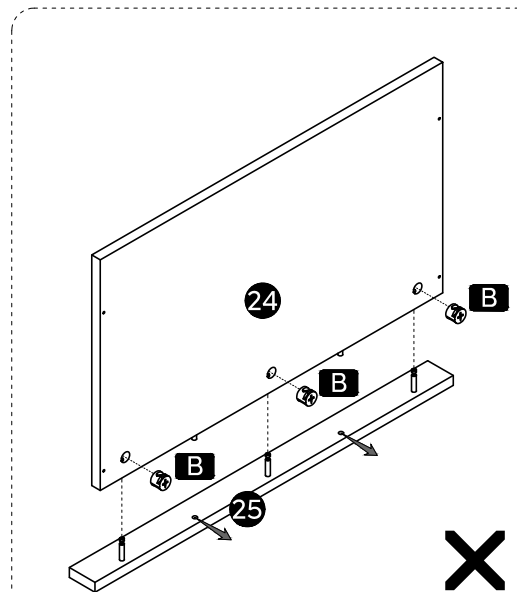
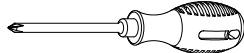

20

# 23

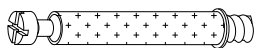
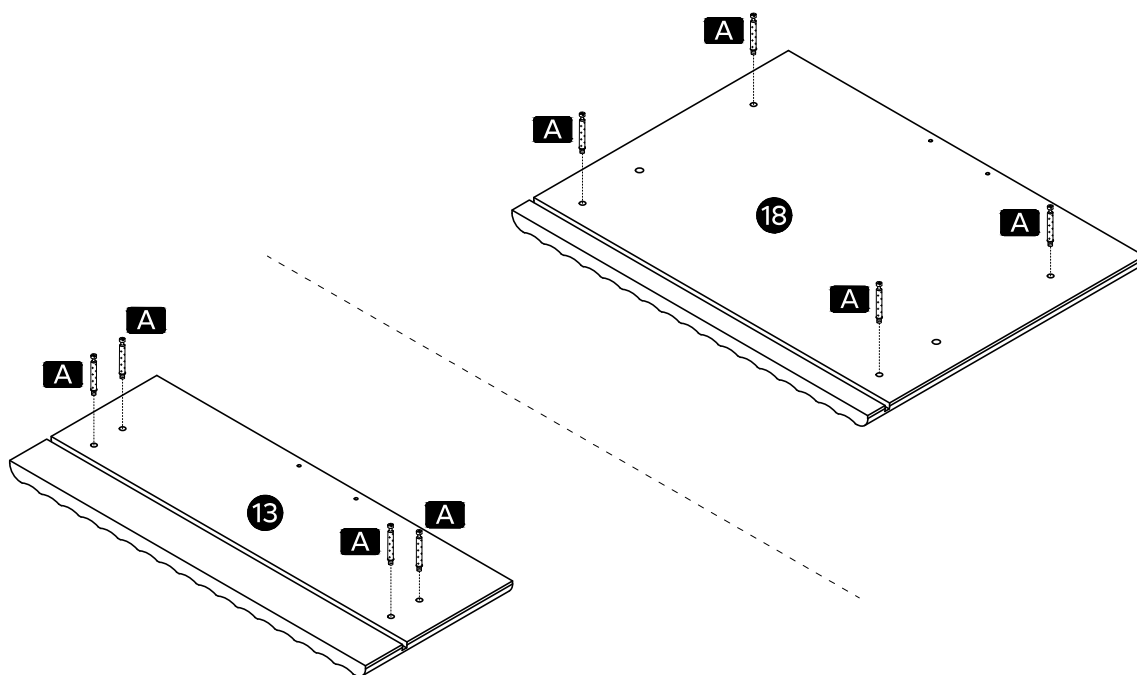

x 8

**A** ST6x35mm

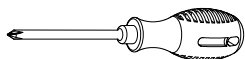

# 24

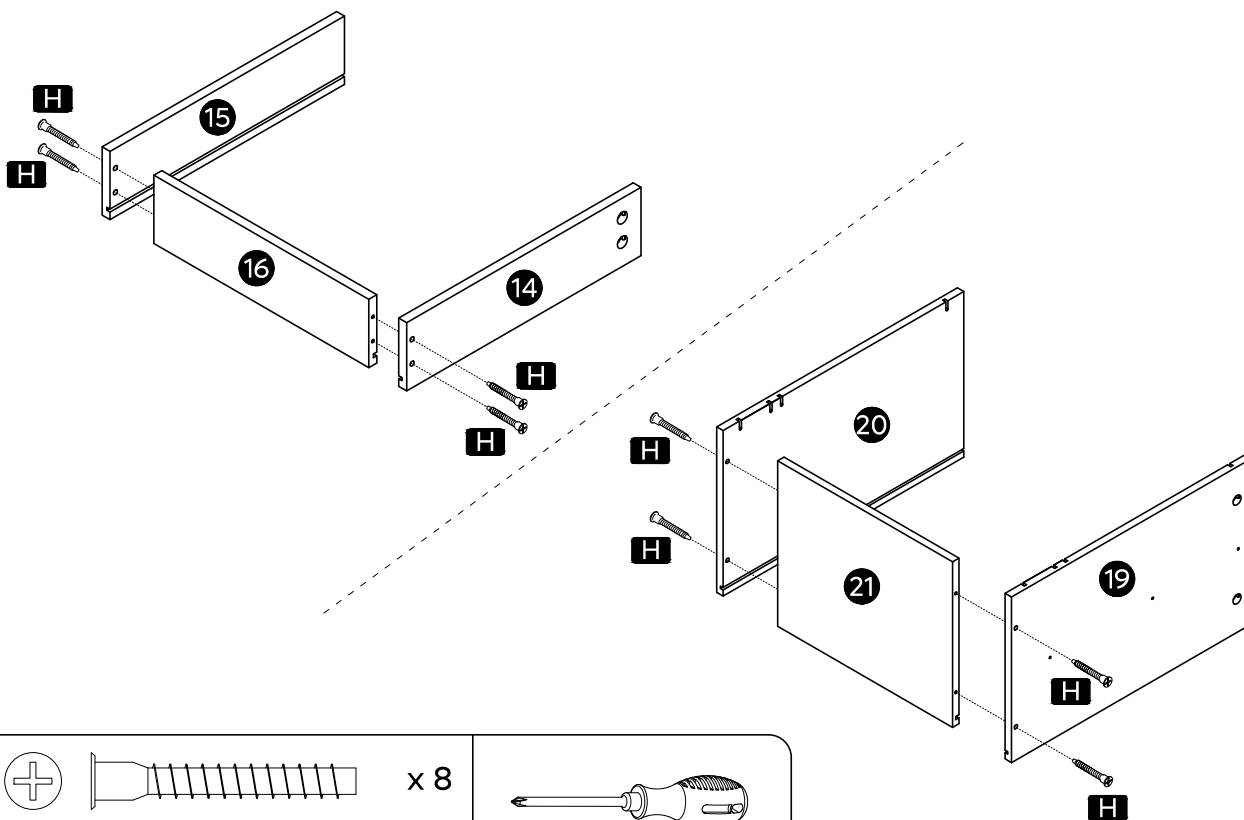

x 8

**H** ST5x35mm

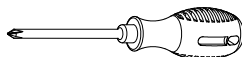

25

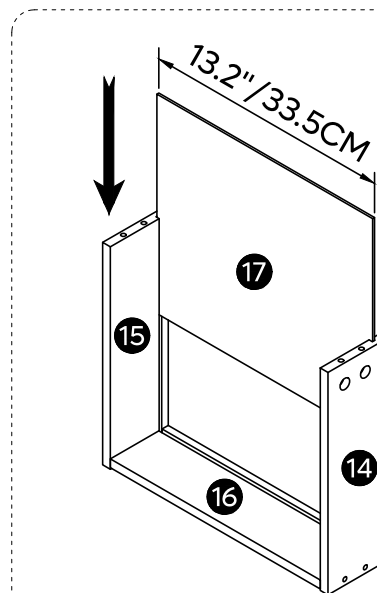
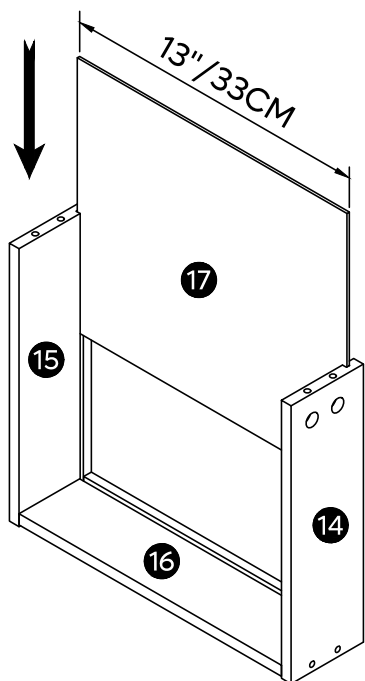

26

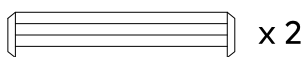
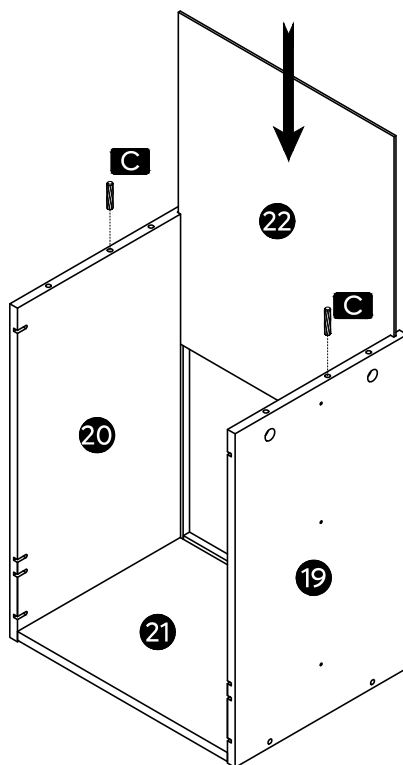

**C** Ø6x30mm

27

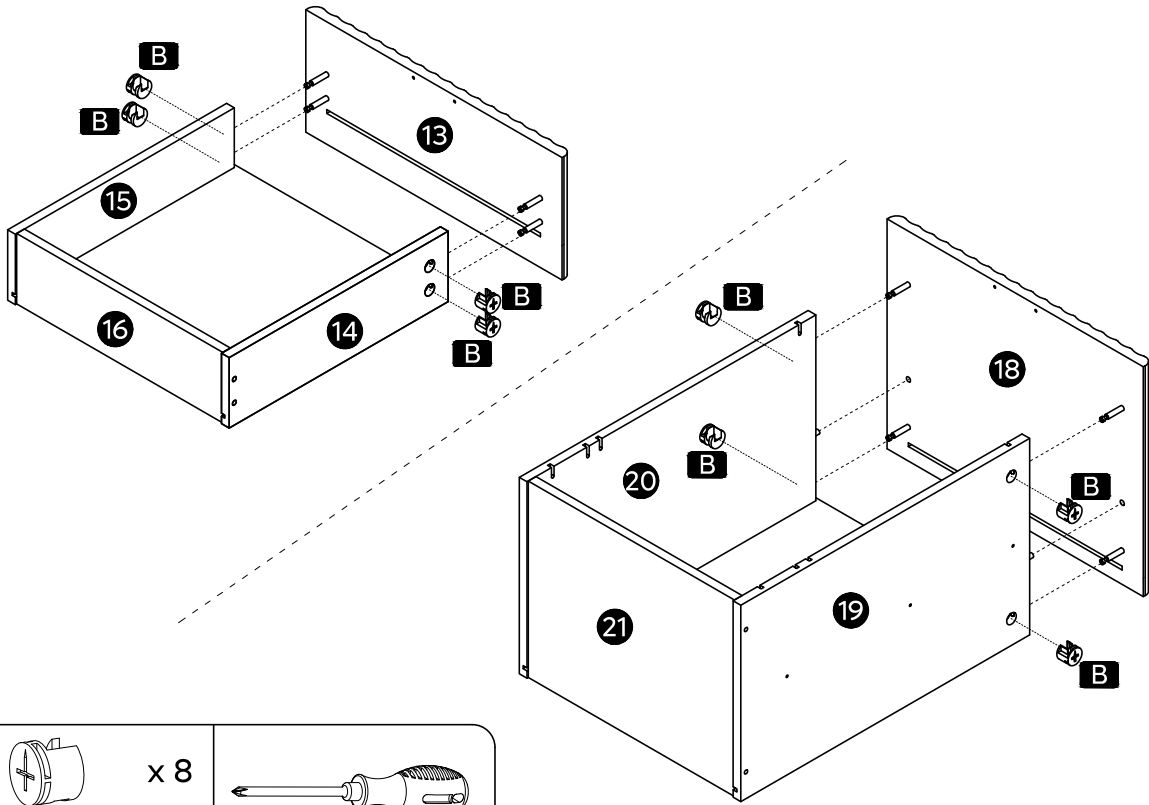

x 8

**B** Ø15mm

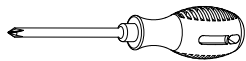

28

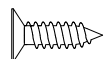
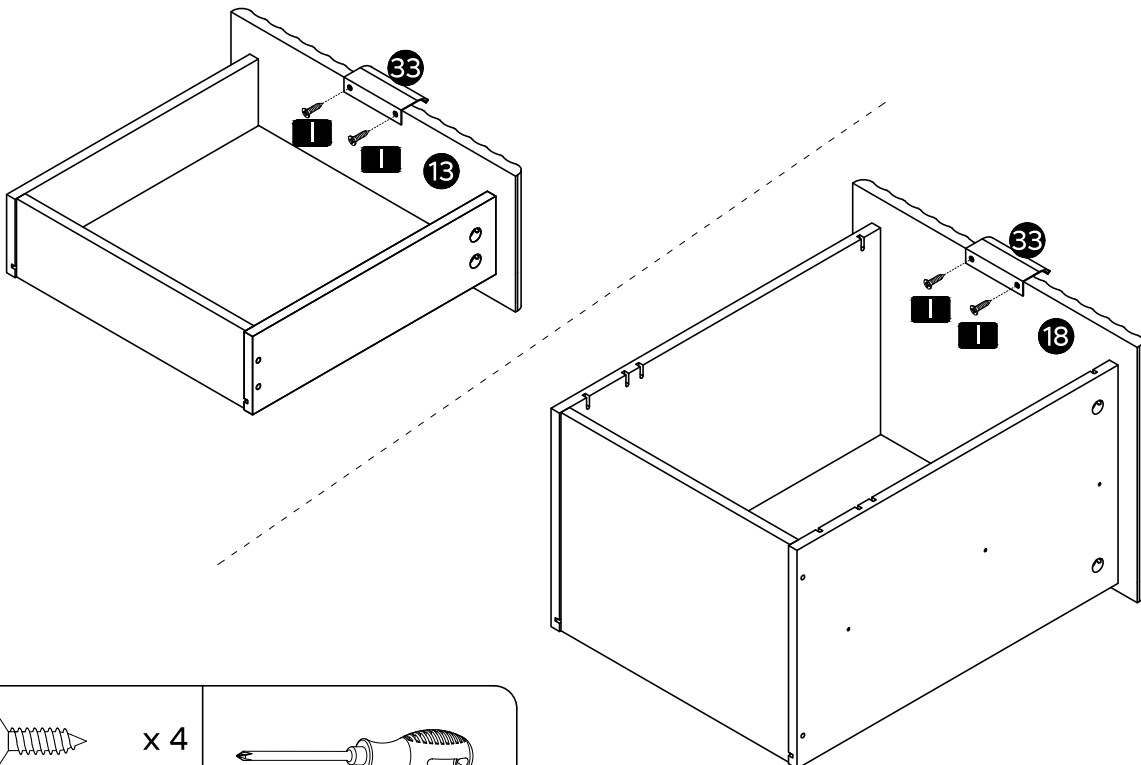

x 4

**I** ST3.5x12mm

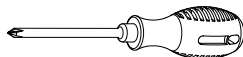

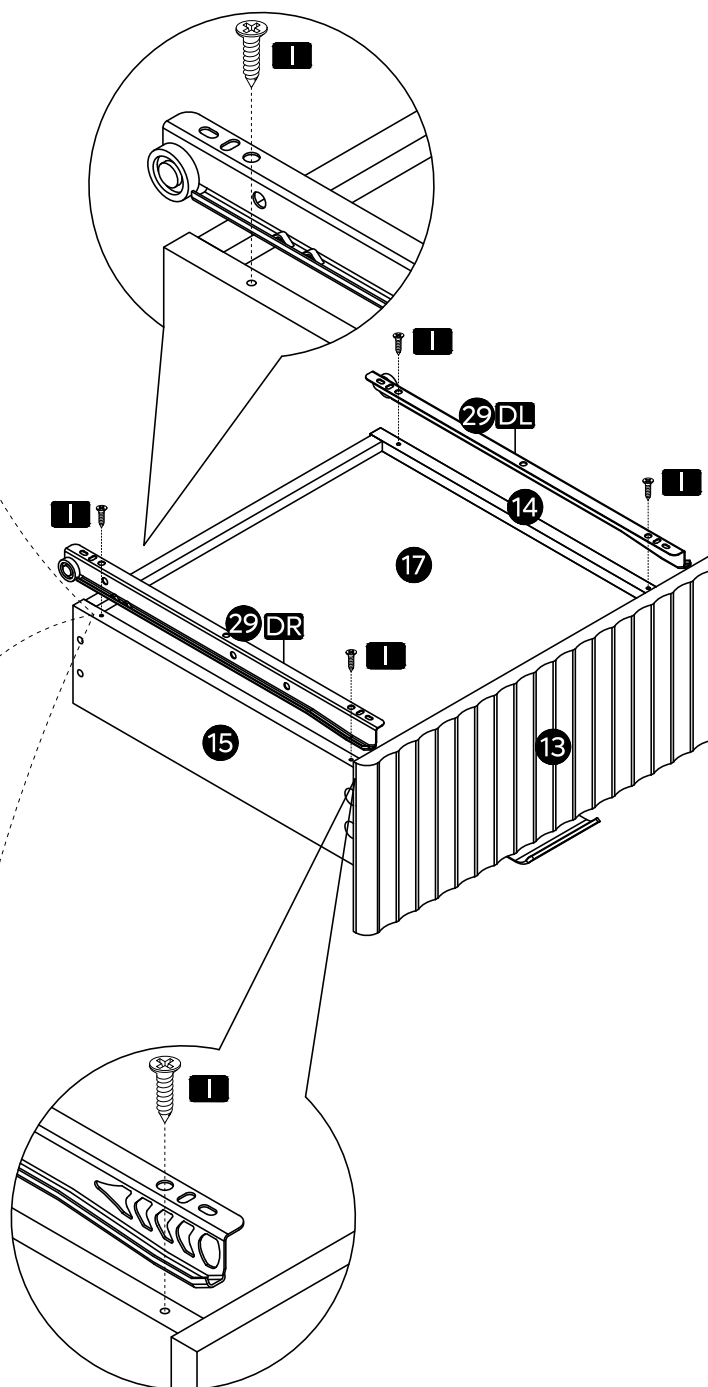
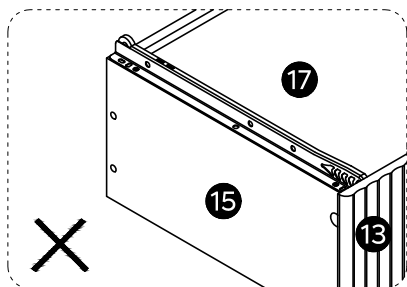
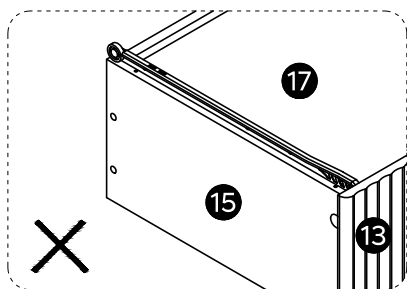
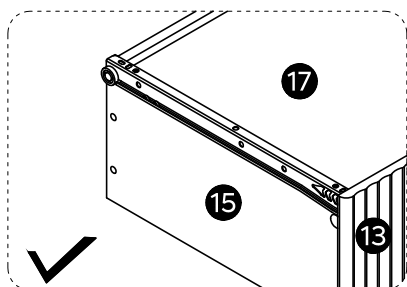

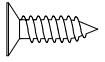

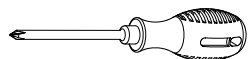
 x 4  
**I** ST3.5x12mm

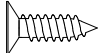
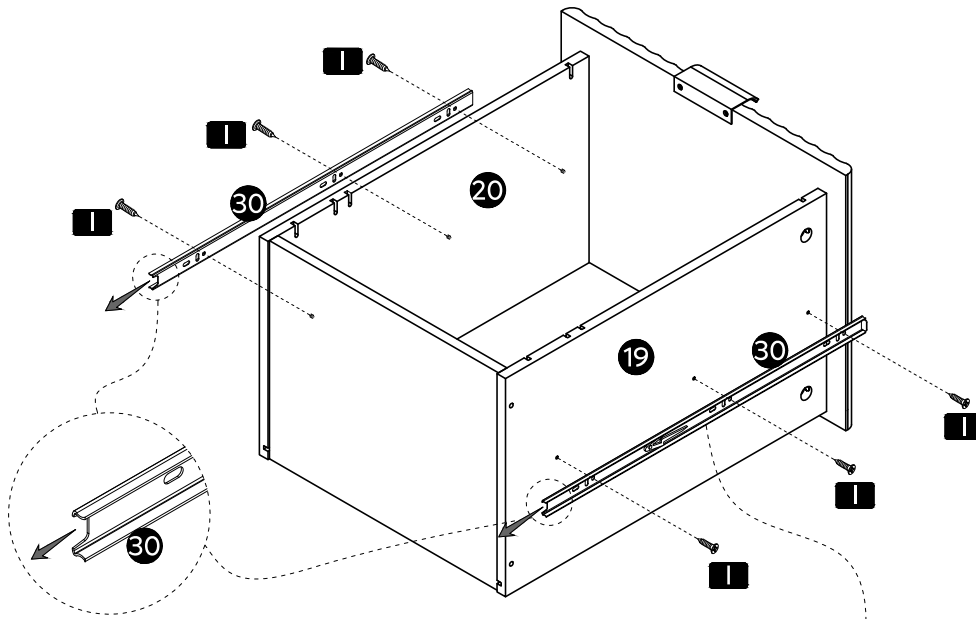

30



x 6

I ST3.5x12mm

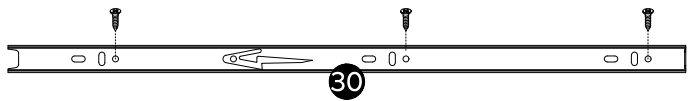
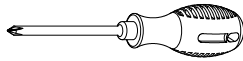

31

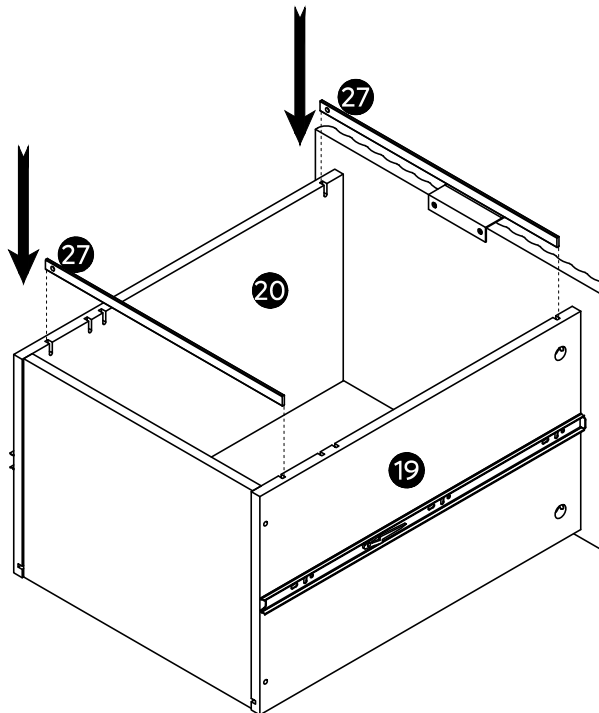

32

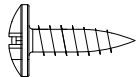
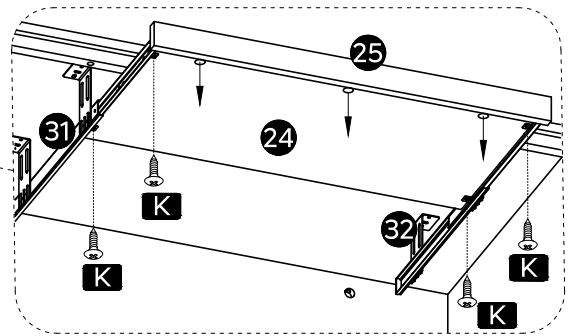
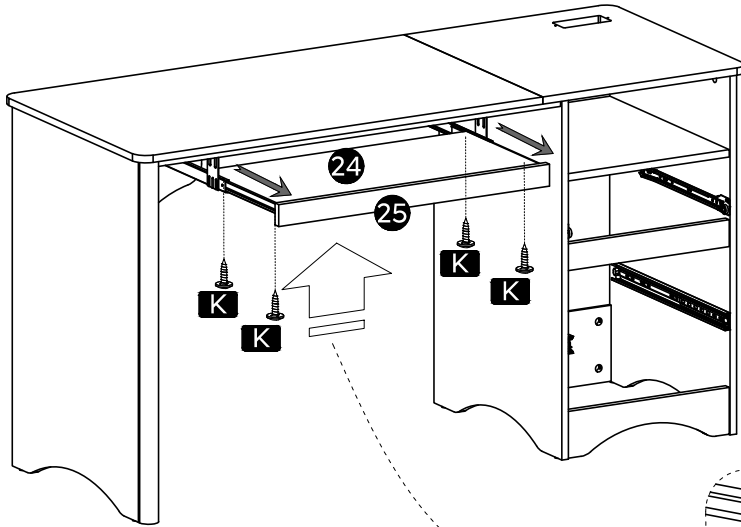

x 4

**K** ST4x14mm

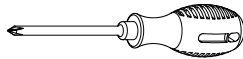

33

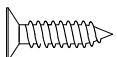
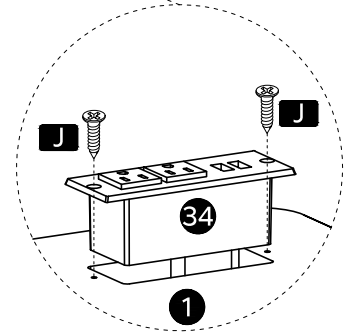
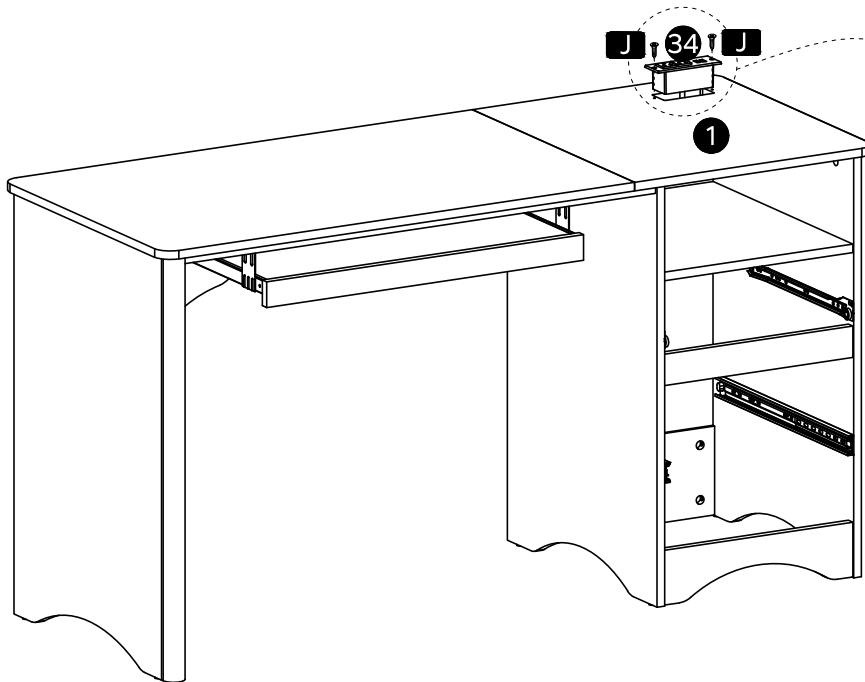

x 2

**J** ST4x14mm

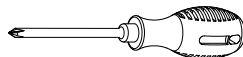

34

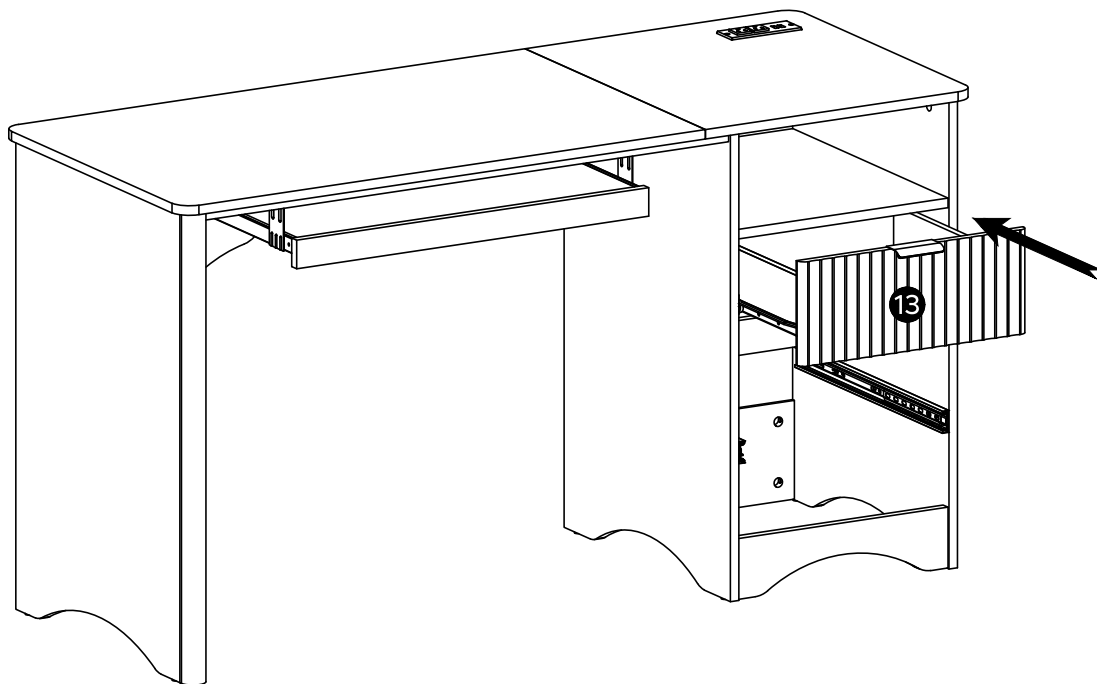

35

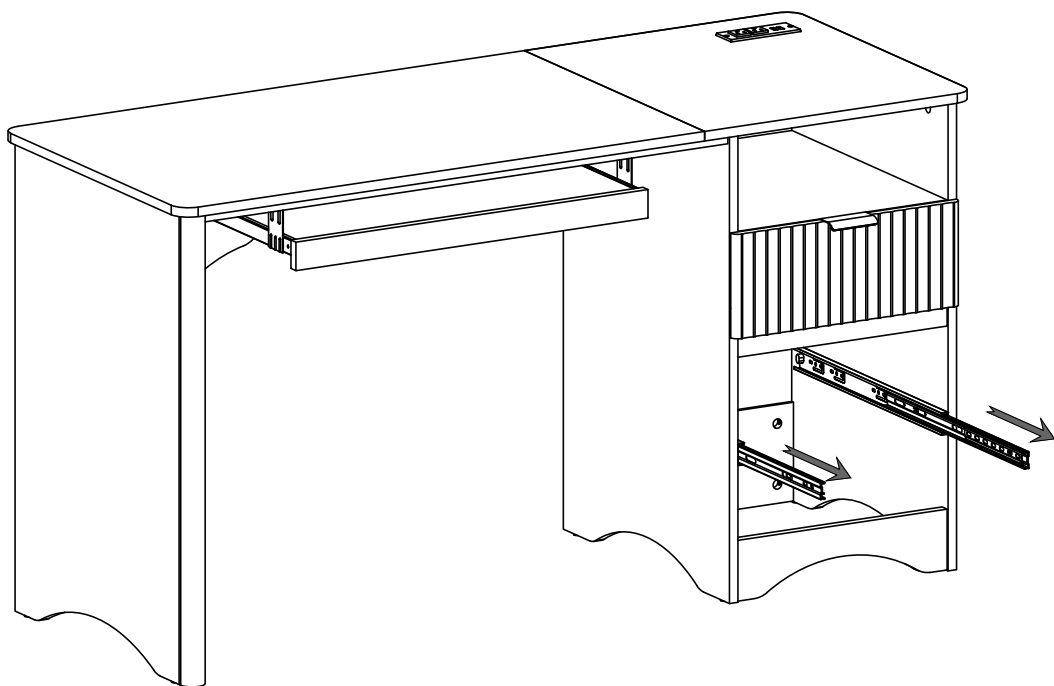

1

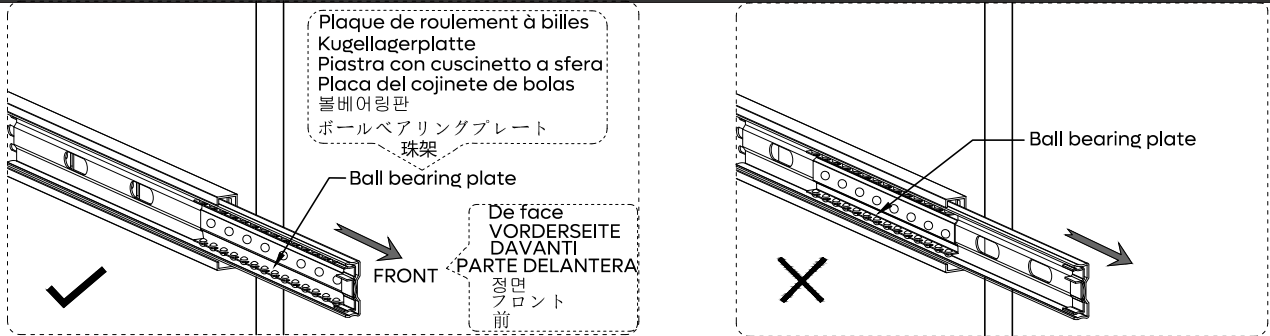

※Before inserting the Drawer, make sure to slide the ball bearing plates located on the Side Frames to the FRONT of the unit as illustrated.

※Avant d'insérer le Tiroir, assurez-vous de faire glisser les plaques de roulement à billes situées sur les cadres latéraux à l'AVANT de l'unité, comme illustré.

※Bevor Sie die Schublade einsetzen, schieben Sie die Kugellagerplatten an den Seitenrahmen wie abgebildet nach VORN.

※Prima di inserire il cassetto, assicurarsi di far scorrere le piastre con cuscinetto a sfera situate sui telai laterali verso la parte anteriore dell'unità, come illustrato.

※Antes de insertar el cajón, asegúrese de hacer deslizar las placas de los cojinetes de bolas situadas en los marcos laterales hasta la parte FRONTAL de la unidad, como puede verse en la ilustración.

※서랍에 삽입하기 전에 사이드 프레임에 있는 볼 탭을 기기의 앞부분으로 밀어 넣으십시오. 그림과 같습니다.

※引き出しを挿入する前に、図のように、サイドフレームにあるボールbearingプレートをユニットの前面にスライドさせてください。

※将两侧板上的导轨球架移至导轨最前端；

2

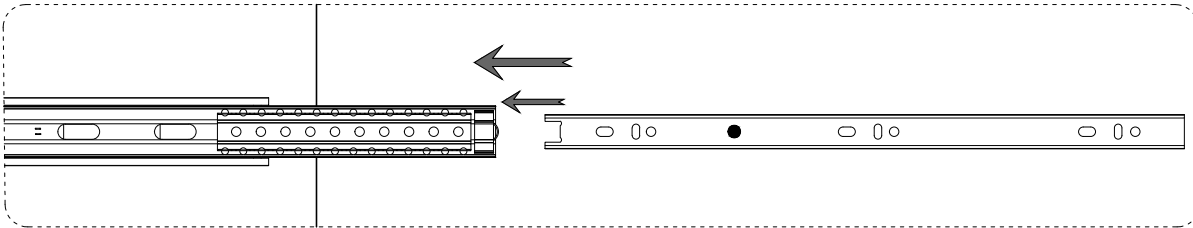

※Insert the rails on both sides of the drawer into the ball bearing plate and slowly push in horizontally.

※Insérez les rails des deux côtés du tiroir dans la plaque de roulement à billes et poussez doucement à l'horizontale.

※Führen Sie die Schienen auf beiden Seiten der Schublade in die Kugellagerplatte ein und schieben Sie sie langsam und waagrecht hinein.

※Inserire le guide su entrambi i lati del cassetto nella piastra con cuscinetto a sfera e spingere lentamente in orizzontale.

※Inserte los carriles de ambos lados del cajón en la placa de cojinete de bolas y empuje lentamente en dirección horizontal.

※서랍 양쪽의 레일을 볼 받침대에 꽂고 천천히 수평으로 밀어 넣는다.

※引き出しの両側にあるレールをボールbearingプレートに差し込み、ゆっくりと水平に押し込みます。

※将抽屉两侧的导轨片，对准导轨最前端，水平缓慢将其推入；

3

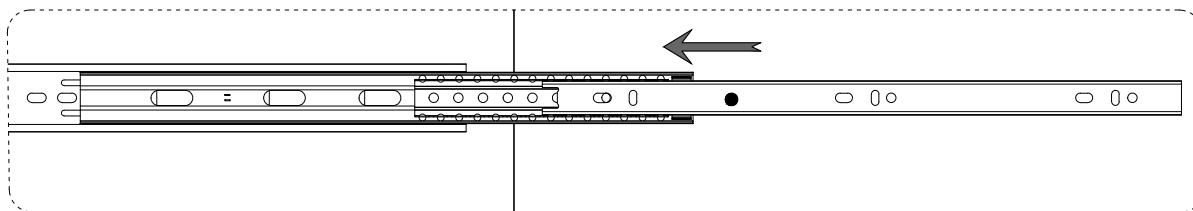

※Note: Push in slowly and horizontally.

※Remarque : poussez lentement et à l'horizontale.

※Hinweis: Schieben Sie sie langsam und waagrecht ein.

※Nota: Spingere lentamente e orizzontalmente.

※Nota Empuje lenta y horizontalmente.

※참고: 느린 수평 밀어넣기.

※注意: ゆっくり水平に押し込みます。

※注意: 水平缓慢推入。

