

ASSEMBLY INSTRUCTIONS
75-125P CATLINS
METAL BED

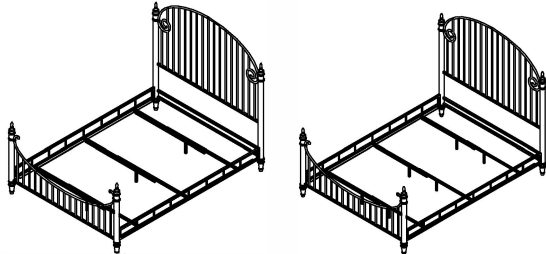

CATLINS QUEEN BED

CATLINS KING BED

IMPORTANT NOTES :

- . Place all parts on the clean and smooth surface such as a rug or carpet to prevent the parts from being scratched.
- . Check to be sure that you have all parts and hardware.
- . Remove all wrapping materials, including staples and packing straps before you start to assemble.
- . Do not tighten all screws and bolts until completely assembled.
- . Keep all hardware out of the reach of children.

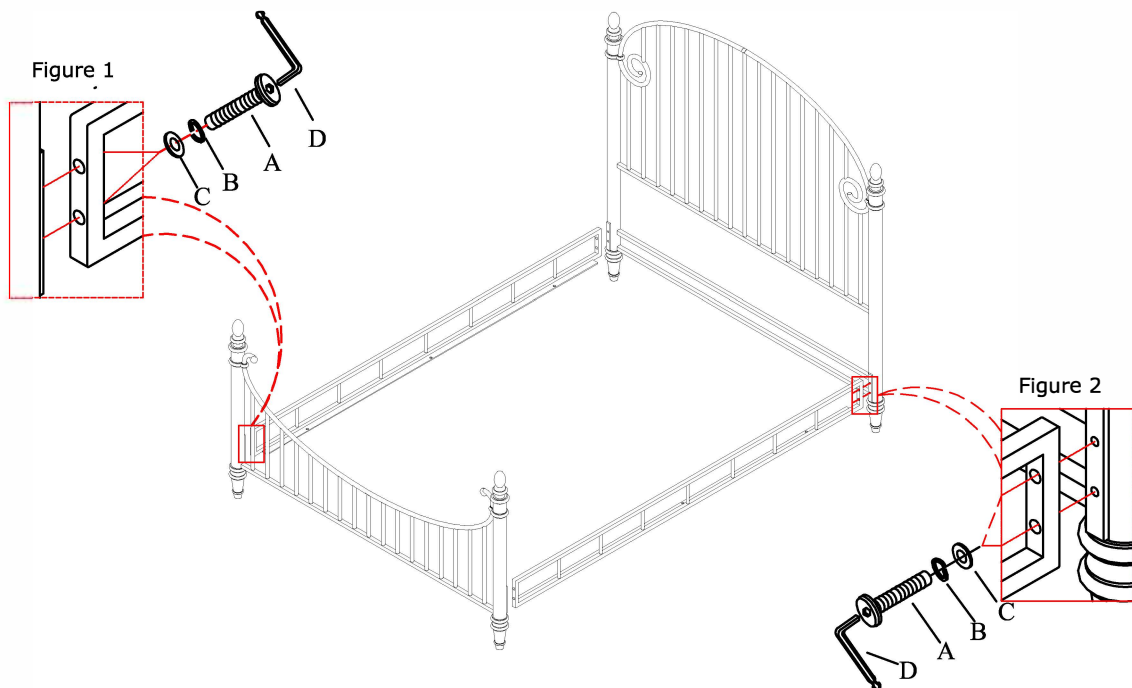

Step 1: Attach the side rail to the footboard and headboard using bolt(A), spring washer(B), flat washer(C) and tighten with the allen wrench(D). (Figure 1 and 2).

HARDWARE LIST

ITEM	DRAWING	DESCRIPTION	Q' TY
A		Bolt (Ø5/16**1-1/4")	8 PCS
B		Spring Washer (Ø5/16")	8 PCS
C		Flat Washer (Ø5/16**19mm)	8 PCS
D		Allen Wrench(5mm)	1 PC
E		Bolt (Ø1/4**3/4")	18 PCS
F		Spring Washer (Ø1/4")	12 PCS
G		Flat Washer (Ø1/4**16mm)	12 PCS
H		Allen Wrench(4mm)	1 PC
I		Nut (Ø1/4**5mm)	12 PCS
J		Wrench 10mm	1 PC

MADE IN VIETNAM

ASSEMBLY INSTRUCTIONS

75-125P

CATLINS METAL BED

Step 2: Attach slats to the side rail using bolt (E), flat washer (G), spring washer (F), nut (I) and tighten with wrench (J) and Allen Wrench (H). (Figure 3)

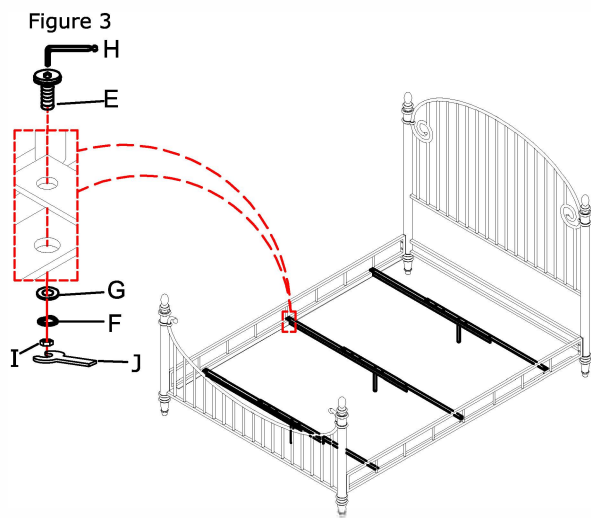

FOR QUEEN BED:

Step 3: Connect two slats together using bolt (E), flat washer (G), spring washer (F), nut (I) and tighten with wrench (J) and Allen Wrench (H). (Figure 4)

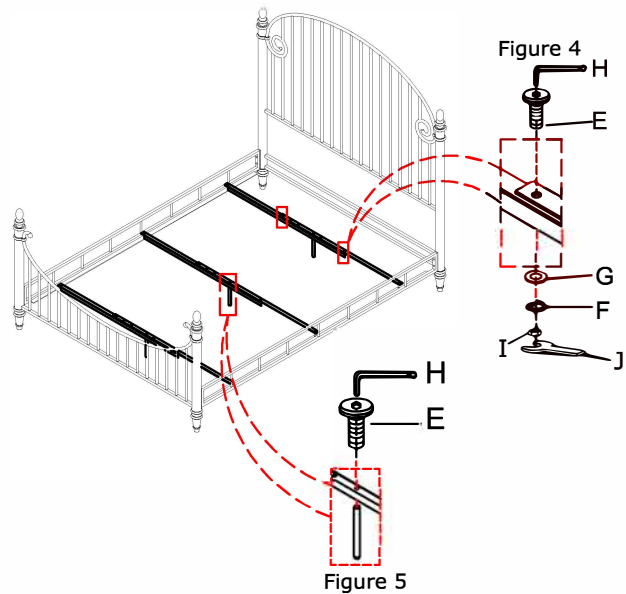

Step 4: Attach the support with slats using bolt (E) and tighten with allen wrench (H). (Figure 5).

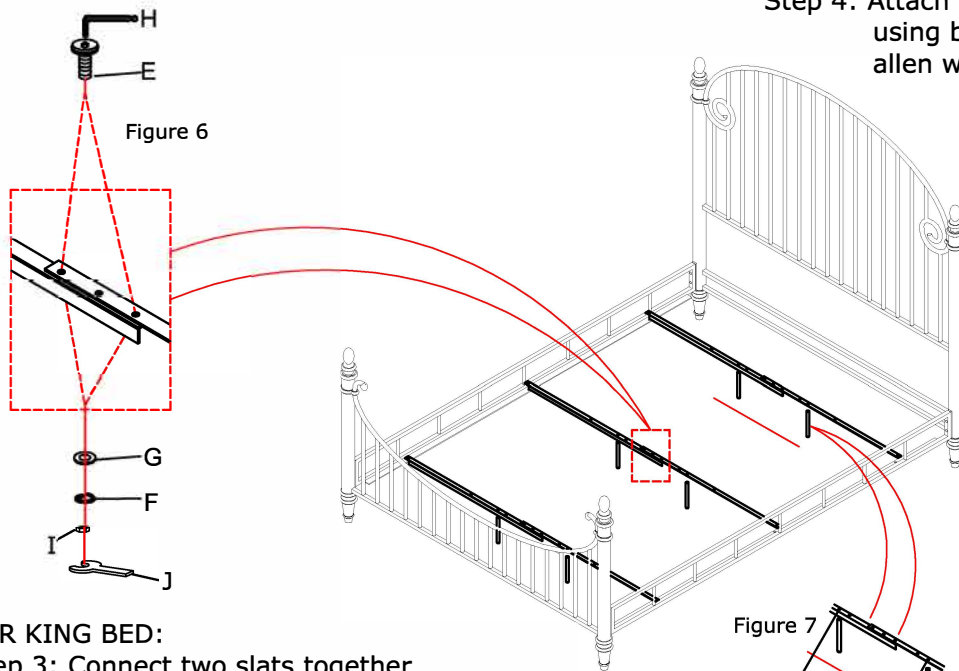

FOR KING BED:

Step 3: Connect two slats together using bolt (E), flat washer (G), spring washer (F), nut (I) and tighten with wrench (J) and Allen Wrench (H). (Figure 6)

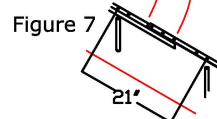

Step 4: Attach the support with slats using bolt (E) and tighten with allen wrench (H). (Figure 7).

MADE IN VIETNAM