

OUTDOOR 4PCS CONVERSATION SET

ASSEMBLY INSTRUCTIONS

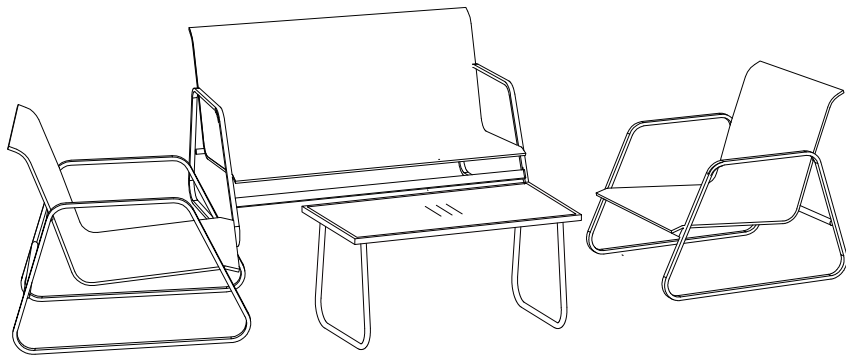



ASSEMBLY INSTRUCTIONS



- Prior to assembly, make sure you lay out and identify all the parts listed in the parts list below.
- Tighten all nuts and bolts securely. All bolts should be hand tightened before use. Never use power tools or excessive force during assembly or for tightening of bolts.
- Should you experience any difficulty during assembly or if any parts are missing or damaged:
Contact our customer service.

Warning:

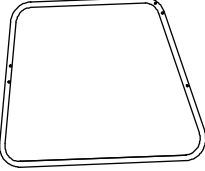
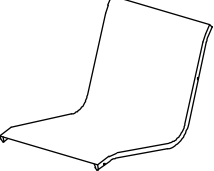
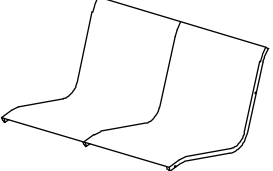
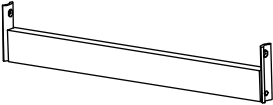
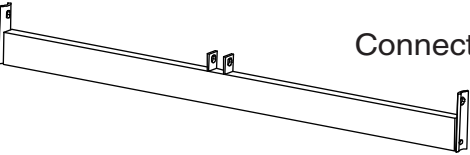



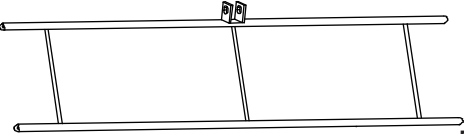
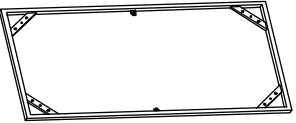

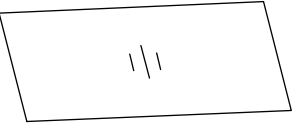

1. Make sure the conversation set is placed on a solid, level surface.

Part List

Part	Description	Qty
A	 Leg	6
B	 Single Seat	2
C	 Double Seat	1
D	 Connecting bar	2
E	 Connecting bar	1
F	 Supporting bar	4
G	 Supporting bar	4

Part	Description	Qty
H	 Back Frame	1
I	 TableTop Frame	1
J	 Table Leg	2
K	 Top Glass	1

Hardware Bag

 M6*20	 M6*32	 M6*42	 M6*60
L*8	M*2	N*18	O*12
 P*6	 Q*54	 R*1	 S*1

SINGLE CHAIR

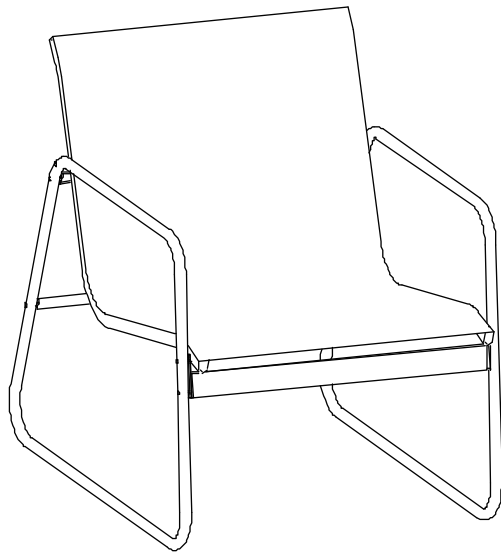

Don't screw thoroughly until Step 5.

1. Place legs (Part A) together by connecting bar (Part D) using bolt N and washer Q. Then affix the two connect bars (Part G) to legs (Part A) separately by using bolt N, and washer Q.

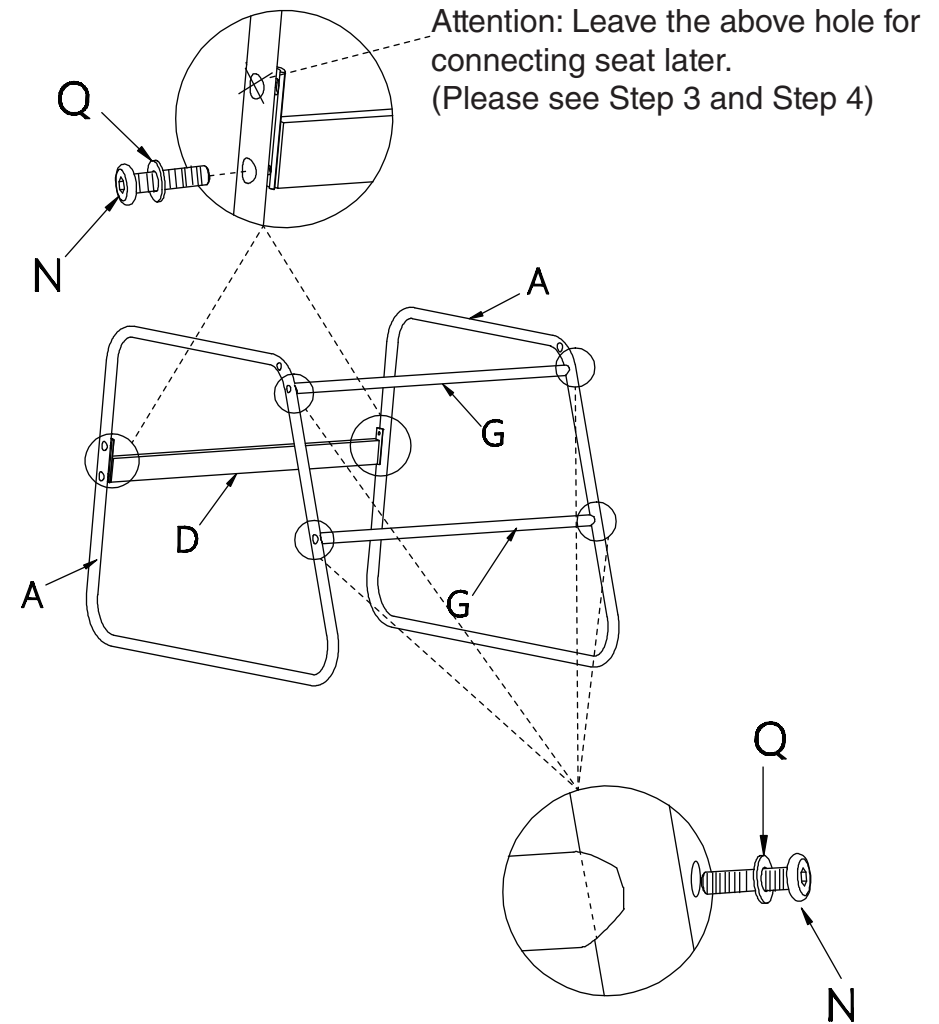

2. Attach supporting bar (Part F) under seat (Part B) as show in diagram.

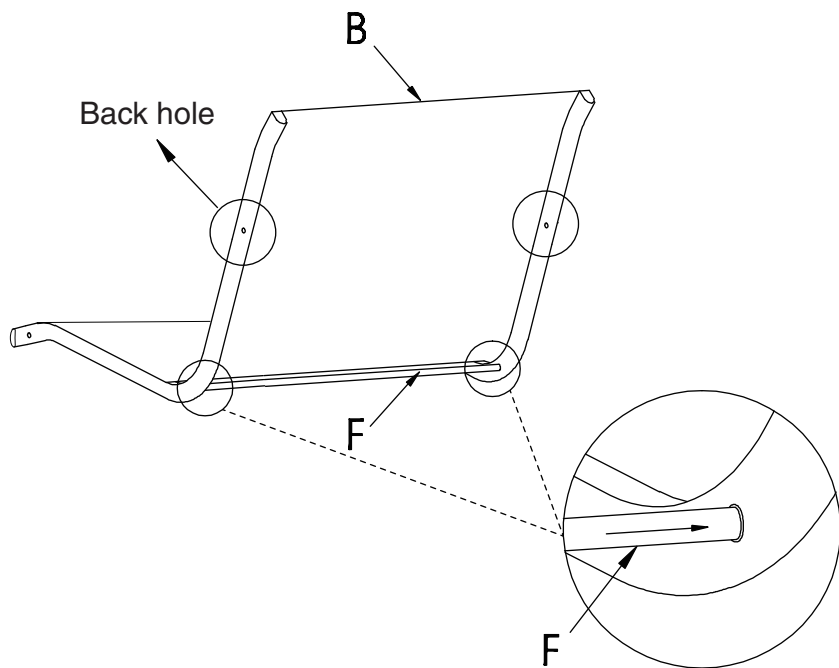

Do not skip this step, It is critical to fit Part F before the next step.

3. Place single seat (Part B) on legs (Part A) using bolt O, washer Q, plastic washer P, and nut as shown in diagram.

 Don't screw thoroughly until Step 5 as shown in diagram

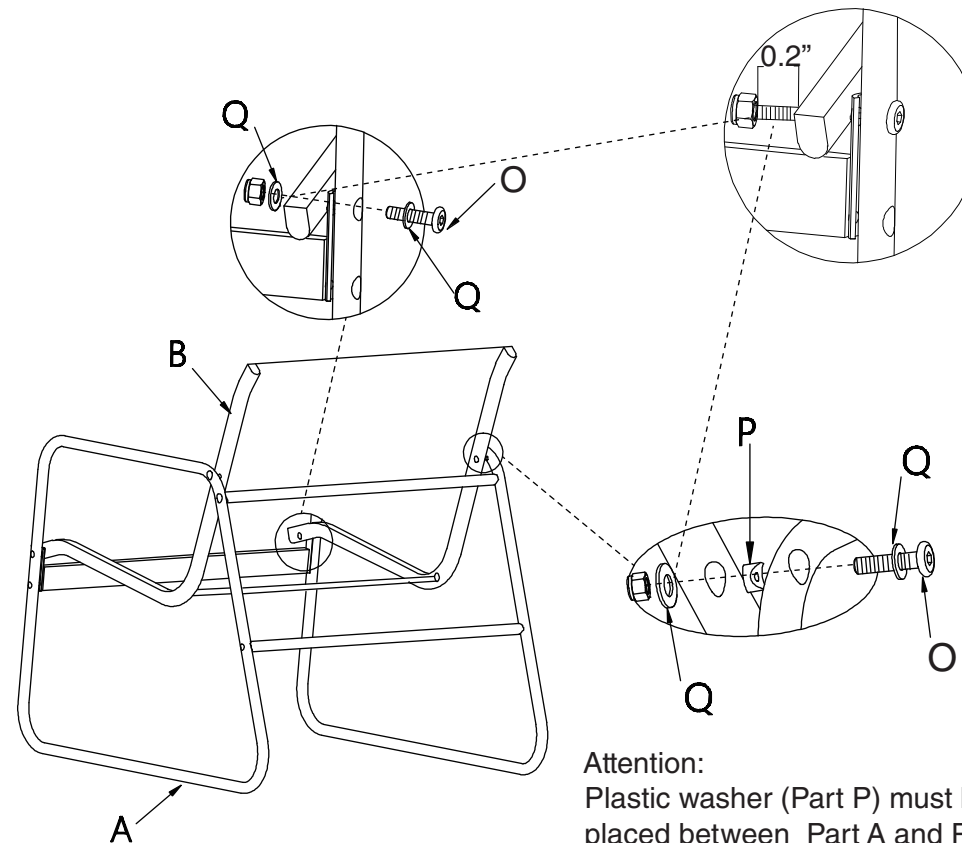

Attention:
Plastic washer (Part P) must be placed between Part A and Part B.

4. Attach other side of seat (Part B) to leg (Part A) using bolt O, plastic washer P, washer Q, and nut as shown in diagram.

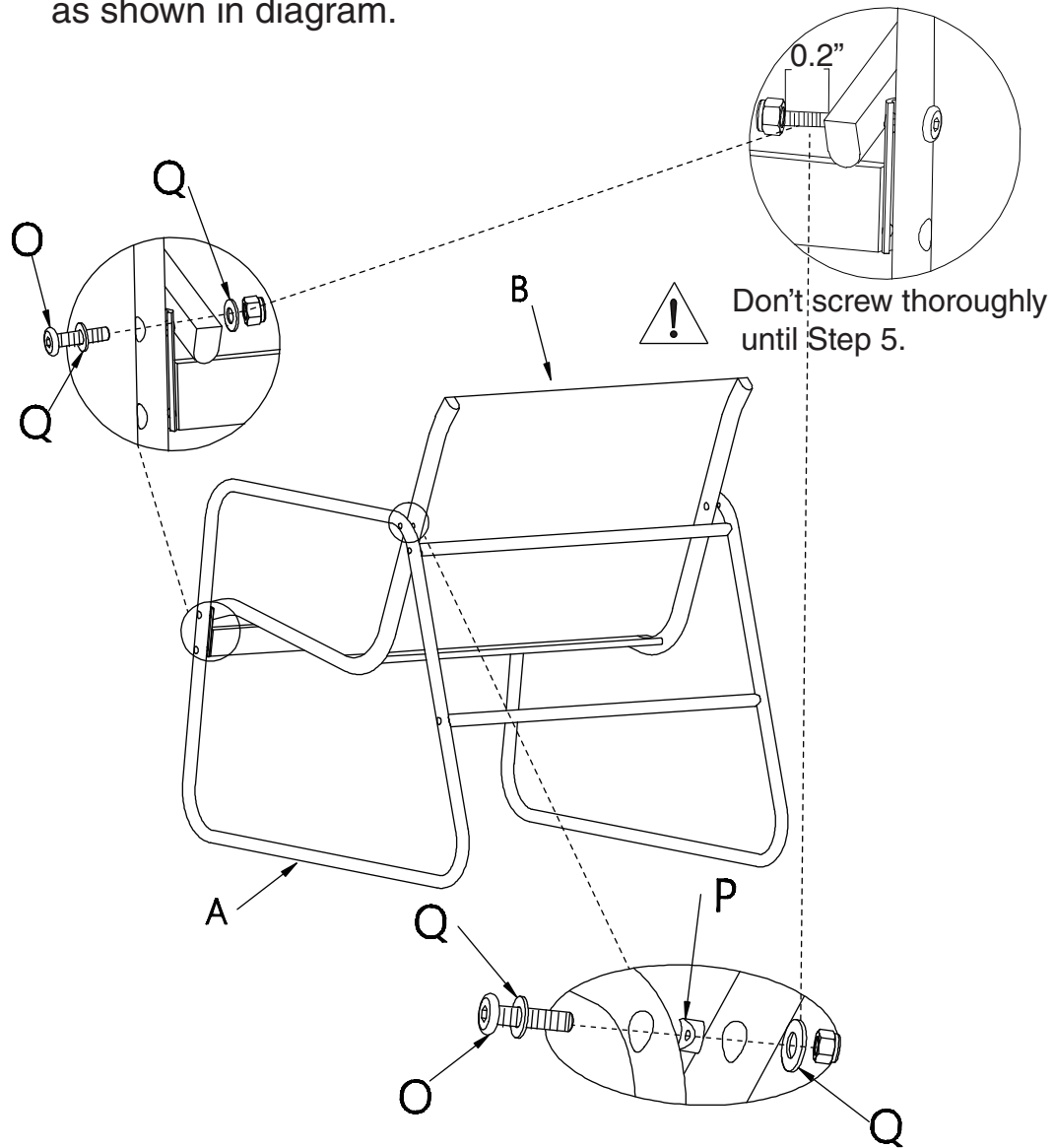

Attention: Part P must be placed between Part A and Part B.

5. Once finished, tighten all nuts and bolts securely before use.

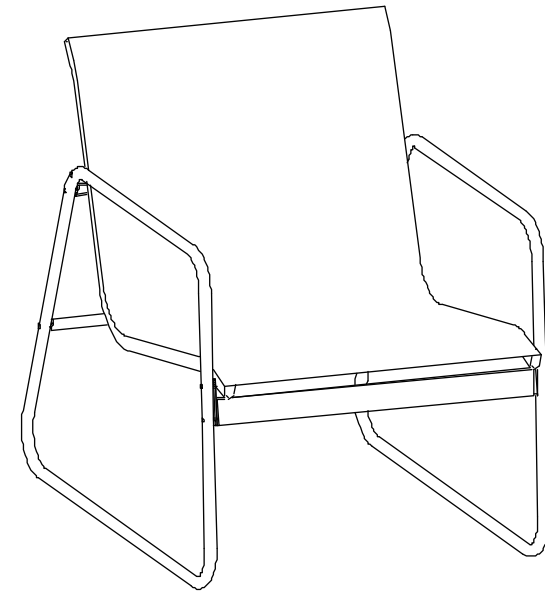

6. Repeat steps 1 to 5 for the other single chair.

LOVESEAT

1. First, set up legs (Part A) by connecting bar (Part E) using bolt N and washer Q. Then attach back frame (Part H) to legs (Part A) using bolt N and washer Q as shown in diagram.

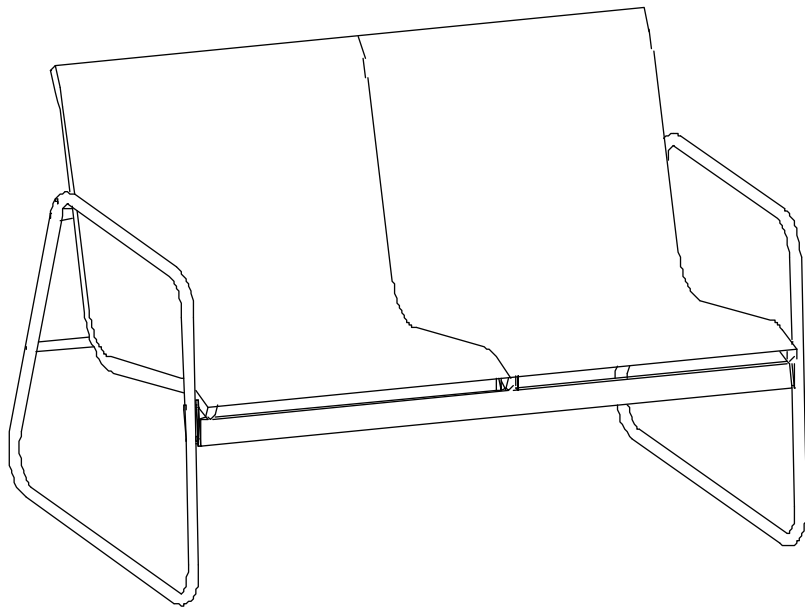

 Don't screw thoroughly until Step 5.

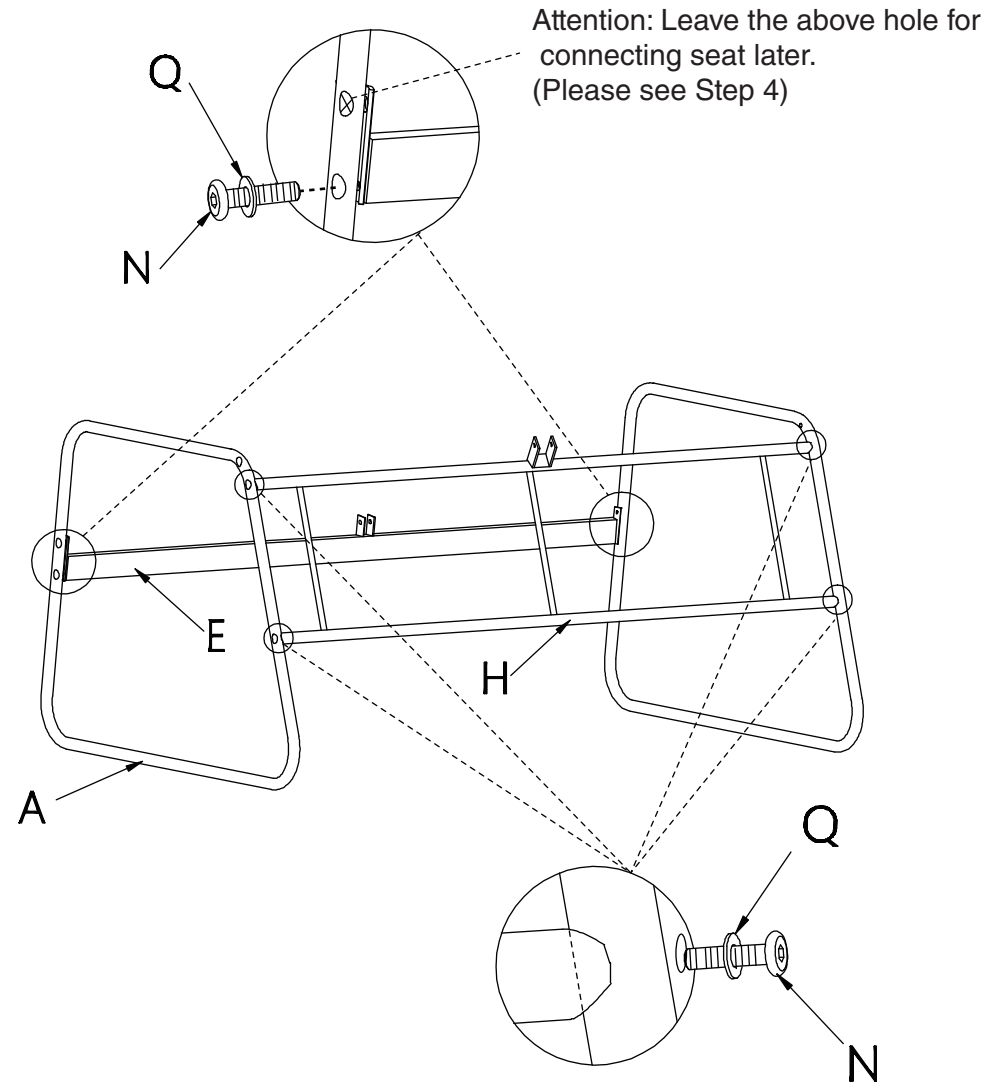

2. Attach supporting bar (Part F) under seat (Part C) as show in diagram.

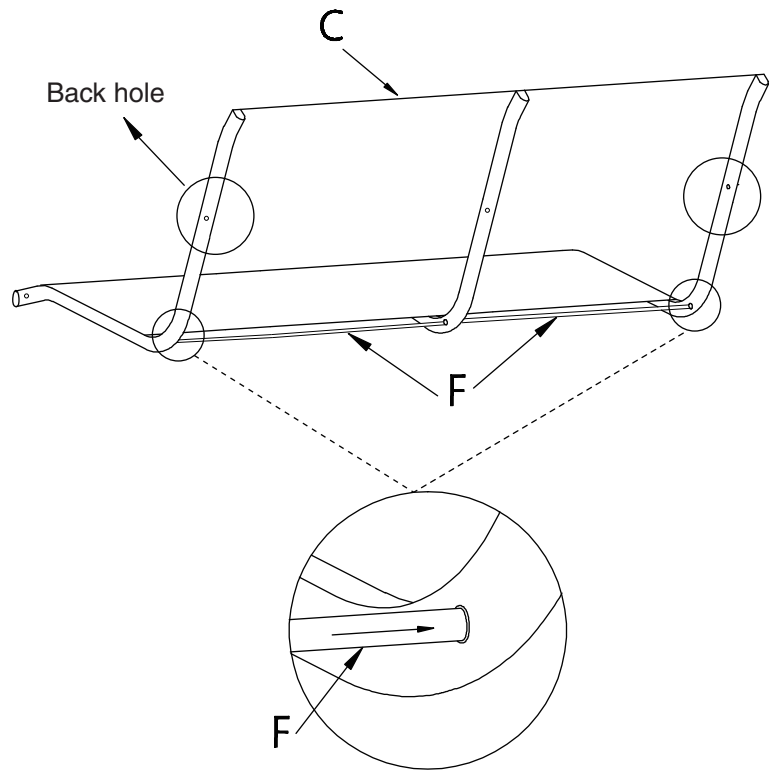

3. Attach the double seat (Part C) to back frame (Part H) and connecting bar (Part E) using bolt M, washer Q and nut as shown in diagram.

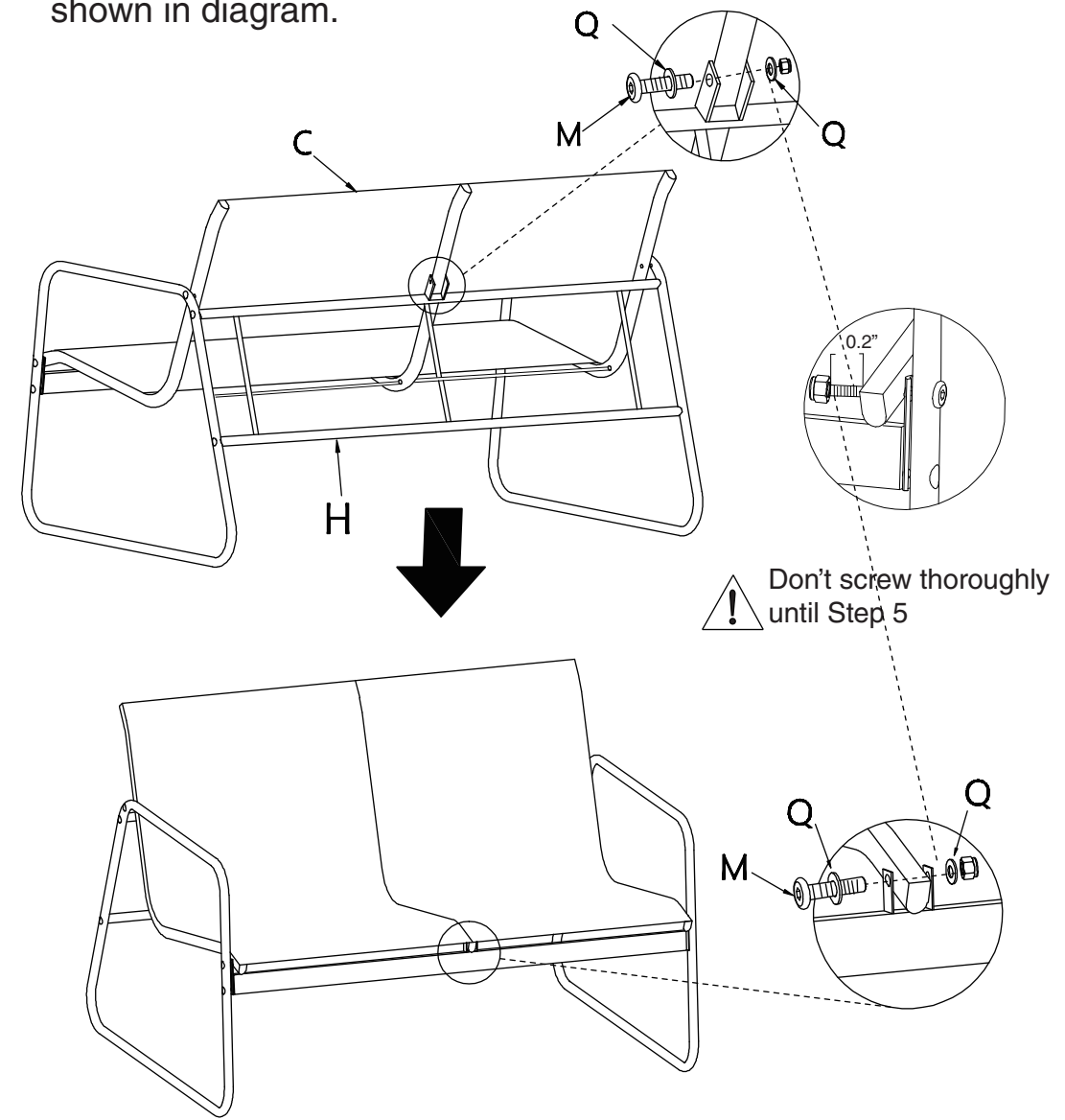

Do not skip this step, It is critical to fit Part F before next step.

4. Attach double seat (Part C) to legs (Part A) using bolt O, washer Q, plastic washer P, and nut as shown in diagram.

Attention: Plastic washer (Part P) must be put between Part A and Part C.

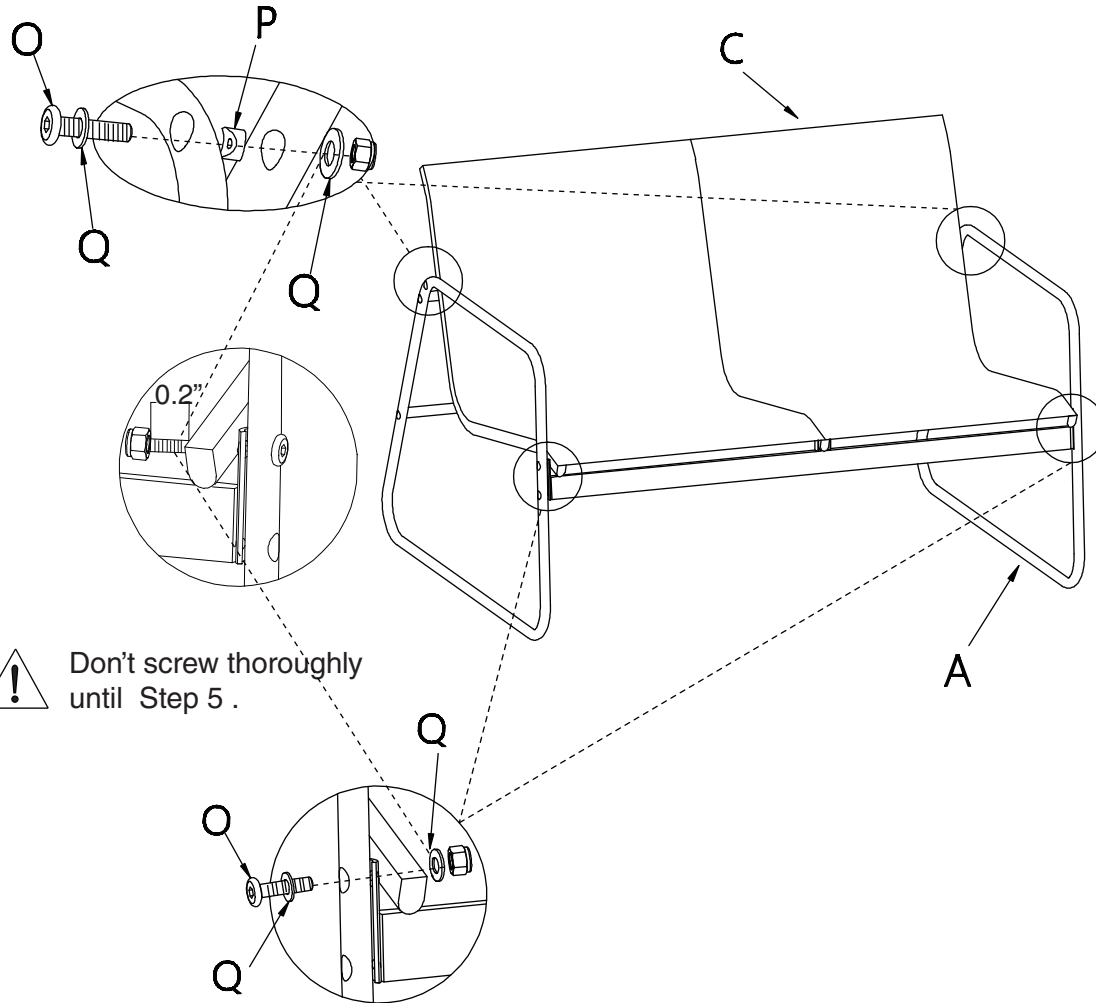

5. Once finished, tighten all nuts and bolts securely before use.

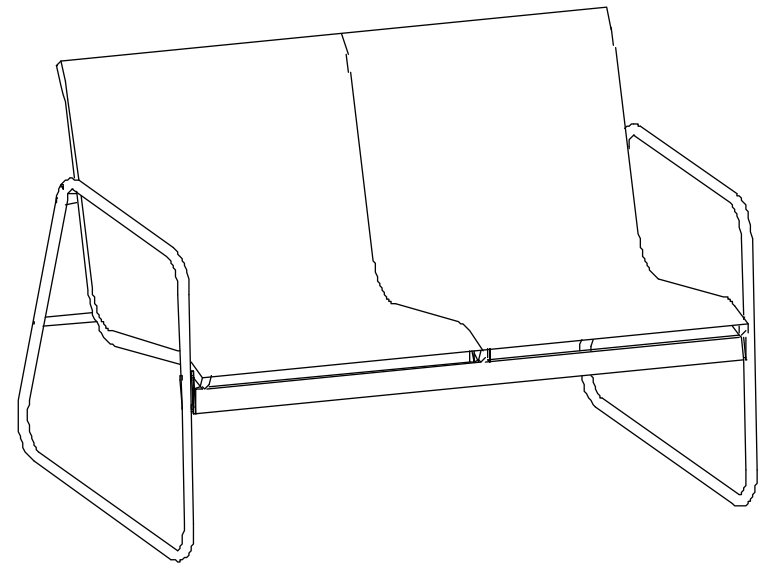

COFFEE TABLE

1. Attach table legs (Part J) to the table top frame (Part I) using bolt L and washer Q as shown in diagram.

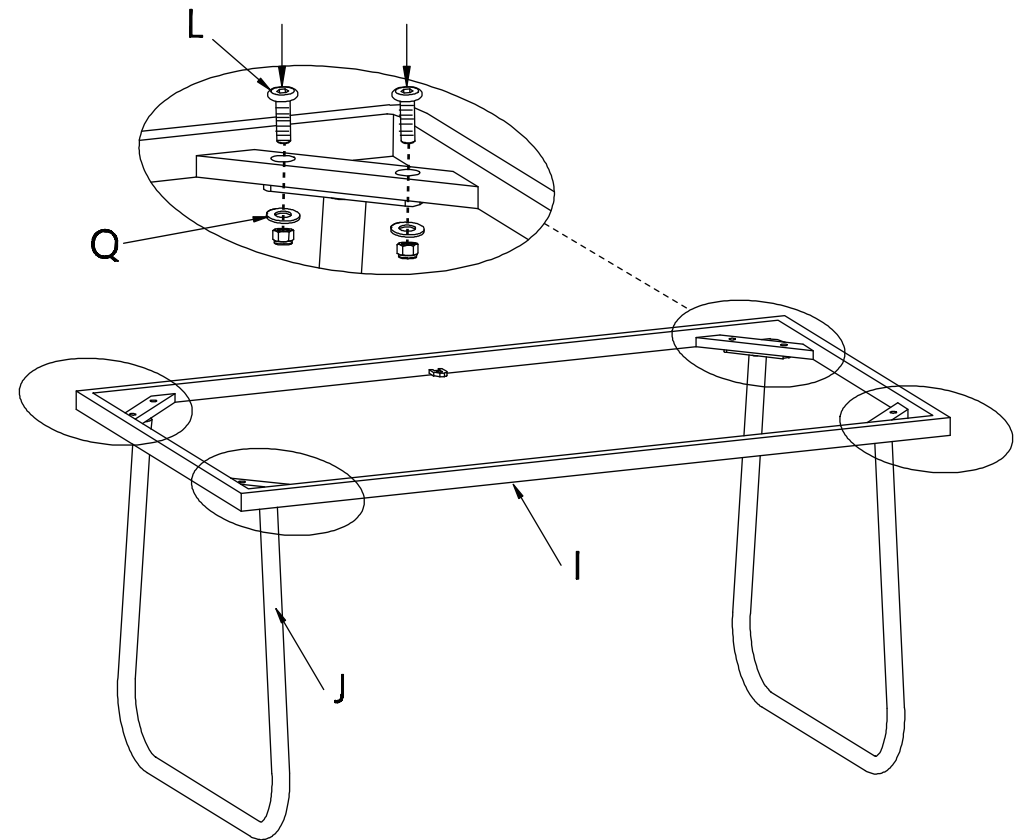
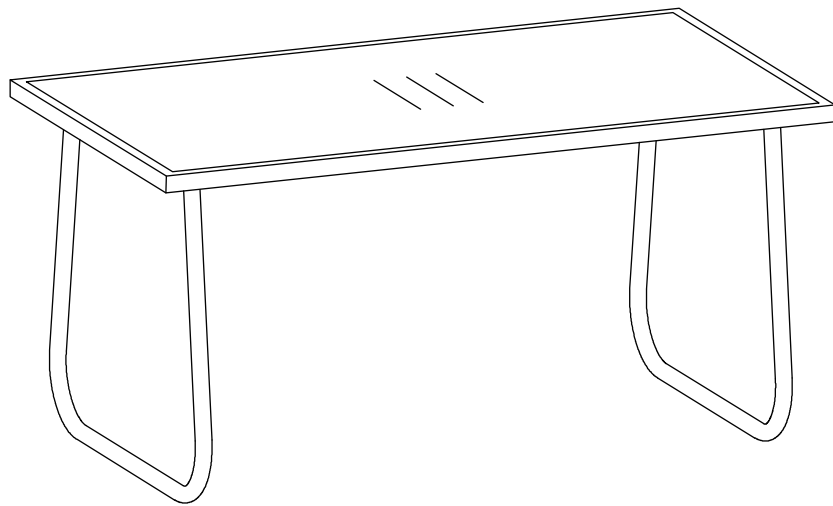

2. Put glass (Part K) on (Part I) as shown in diagram.

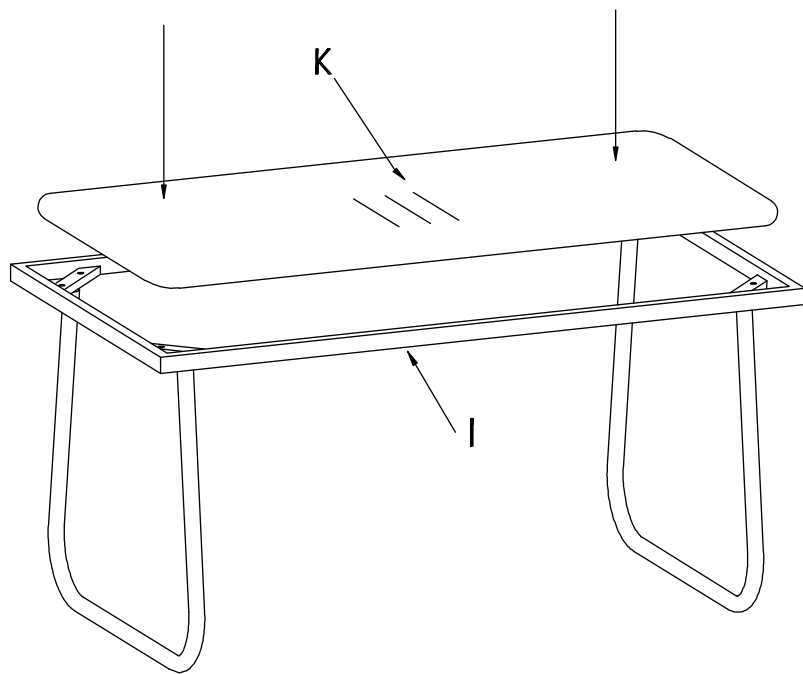

3. Once finished, tighten all nuts and bolts securely before use.