

ASSEMBLY INSTRUCTIONS



Fine Furniture for every stage of life

Dining Table

ASSEMBLY INSTRUCTIONS

ASSEMBLY TIPS:

1. Remove hardware from box and sort by size.
2. Please check to see that all hardware and parts are present prior to start of assembly.
3. Please follow attached instructions in the same sequence as numbered to assure fast & easy assembly.



WARNING!

1. Don't attempt to repair or modify parts that are broken or defective. Please contact the store immediately.
2. This product is for home use only and not intended for commercial establishments.



ASSEMBLY TIME

30 MINUTES

PARTS IDENTIFICATION

B1 (BOX 1)

A TOP



1PC

B LEAF



1PC

B2 (BOX 2)

C LEFT BASE WITH "L" LABEL



1PC

D RIGHT BASE WITH "R" LABEL



1PC

E CROSSBAR



1PC

F COVER CAP



2PCS

HARDWARE IDENTIFICATION

(BOX 2) - HARDWARE PACK IS LOCATED IN (B2)

1 BOLT
($\phi 5/16$ " x 45MM - RBW)



12PCS

3 FLAT WASHER
($\phi 5/16$ " - RBW)



12PCS

2 LOCK WASHER
($\phi 5/16$ " - RBW)



12PCS

4 ALLEN WRENCH
(M4 x 60MM - RBW)



1PC

NOTE:

Phillips head screw driver is required in the assembly process; however, manufacturer does not provide this item.

ASSEMBLY INSTRUCTIONS

STEP 1

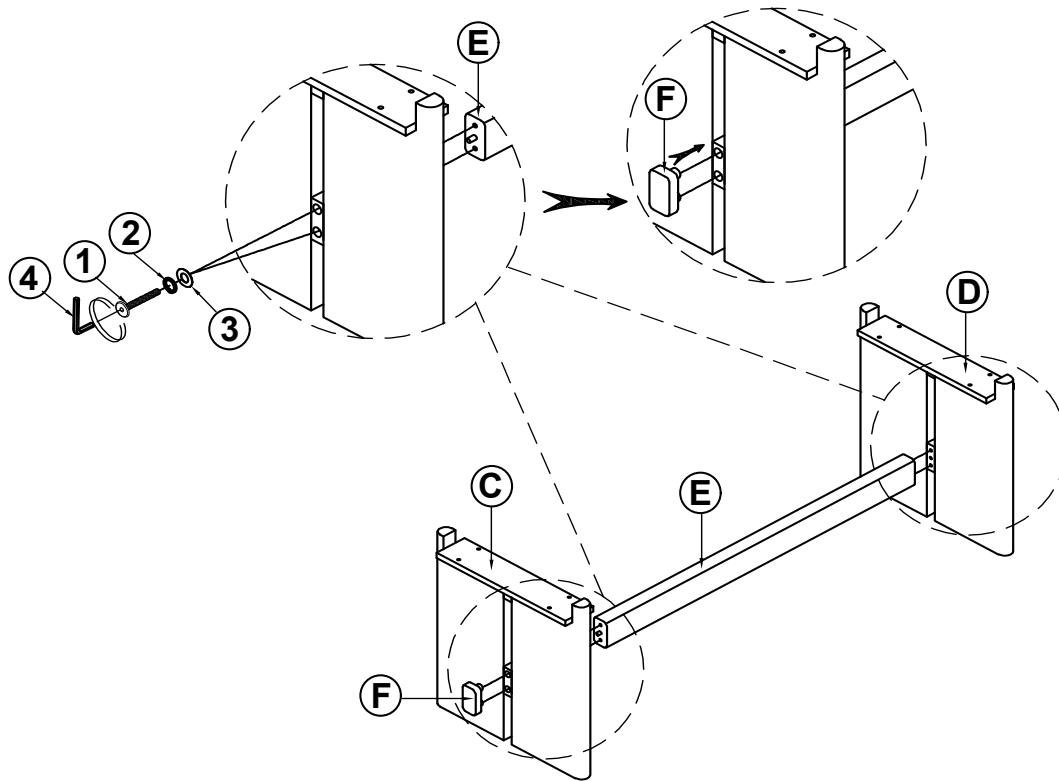

STEP 2

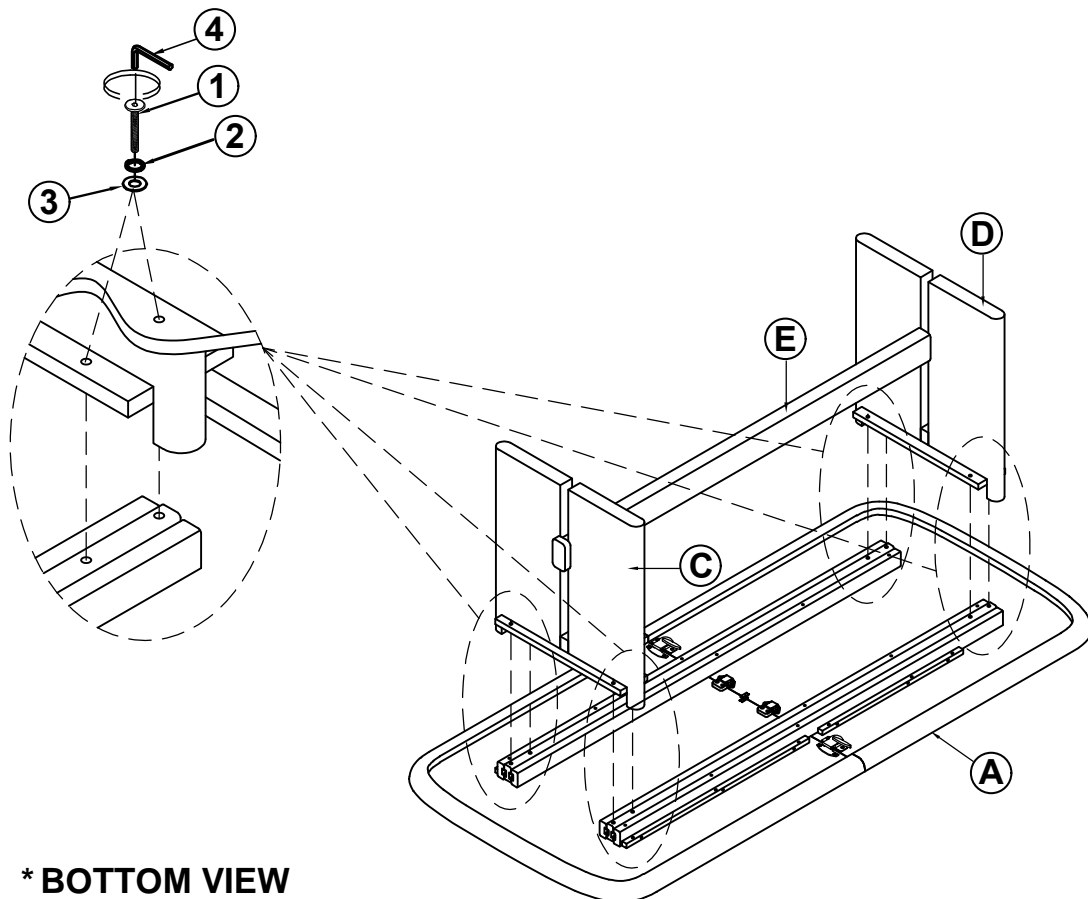

* BOTTOM VIEW

ASSEMBLY INSTRUCTIONS
STEP 3

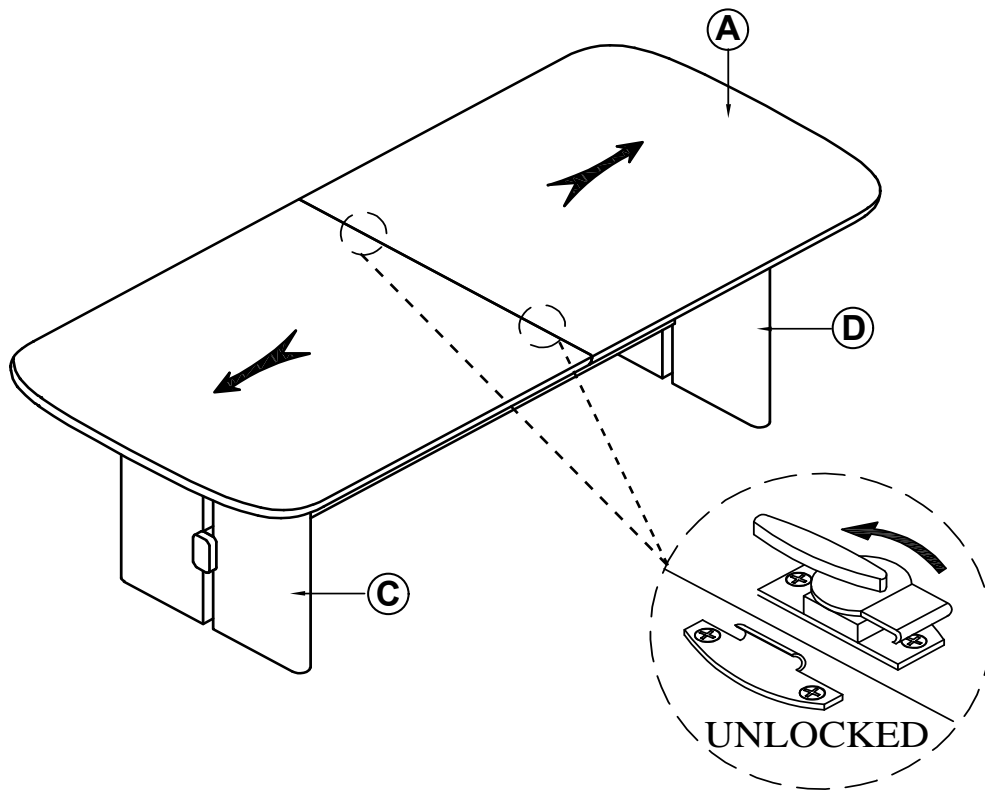

STEP 4

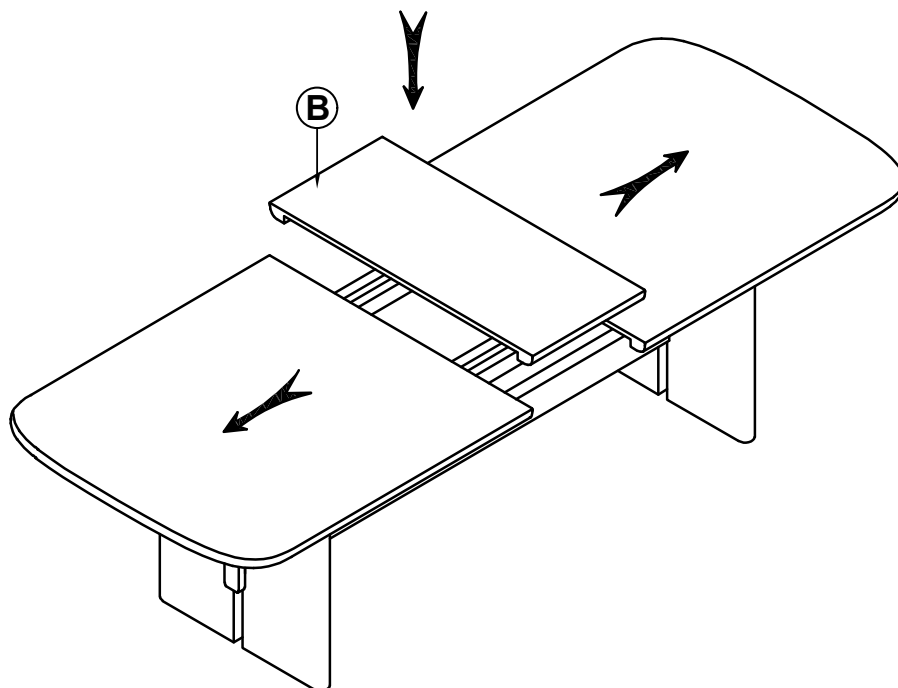

ASSEMBLY INSTRUCTIONS

STEP 5

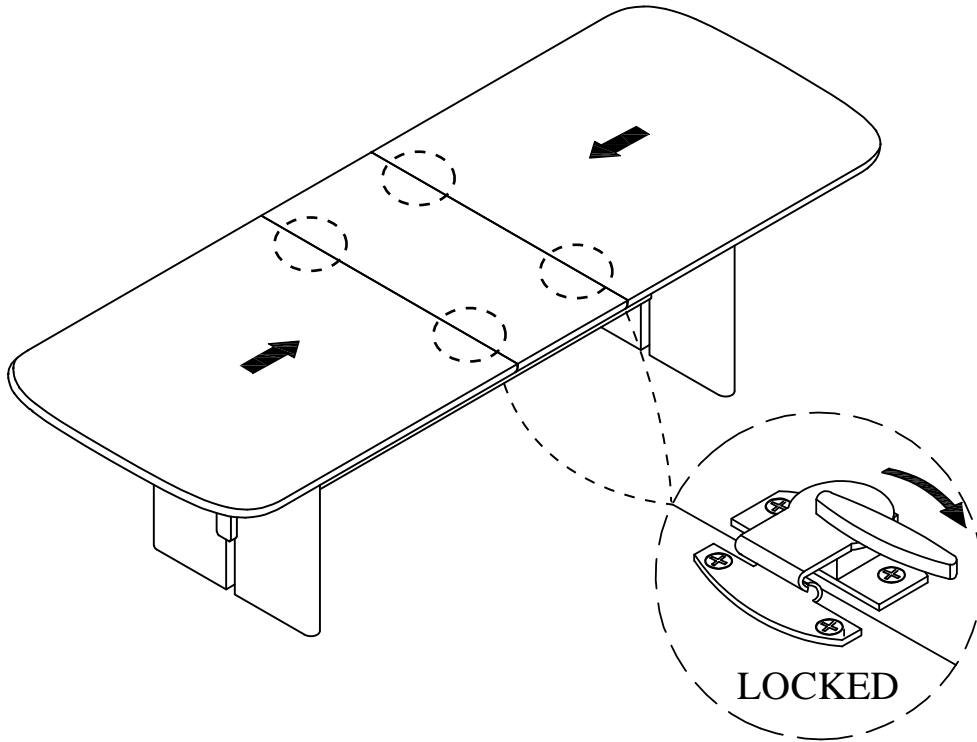

STEP 6

COMPLETE

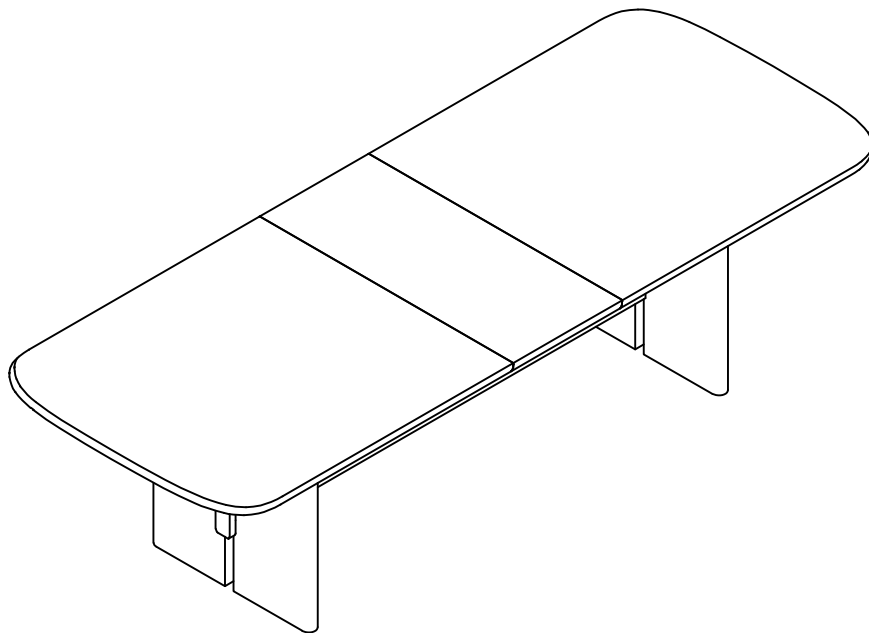

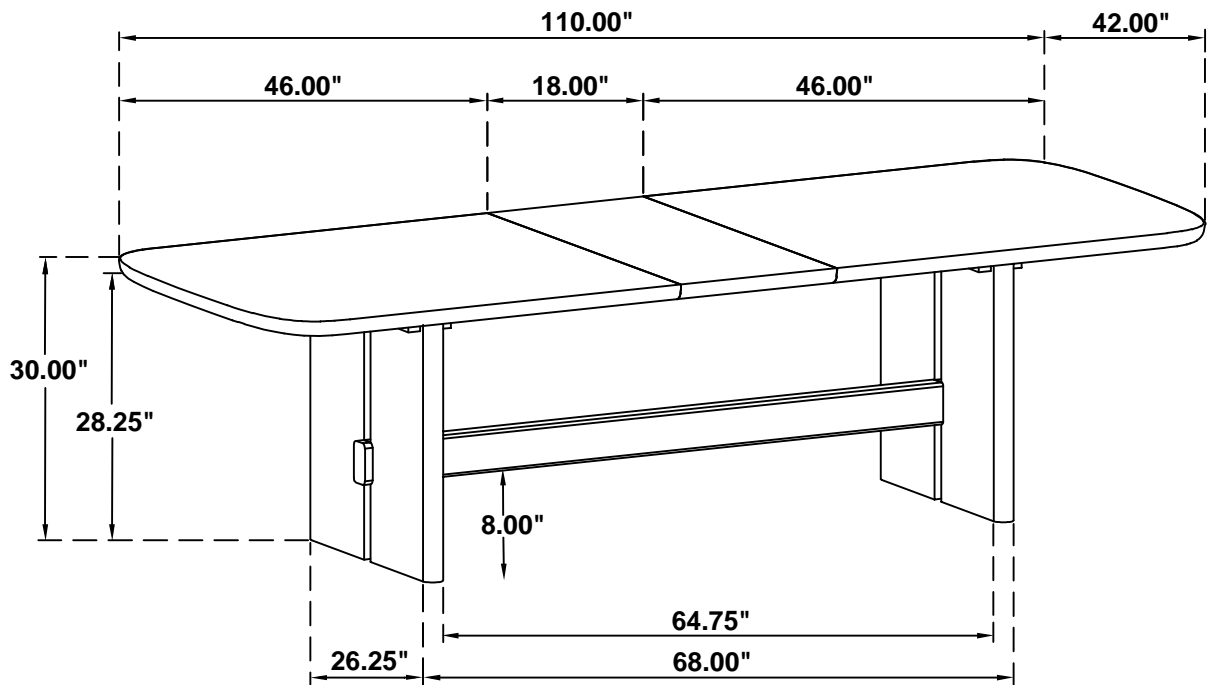

Note: Dimension tolerance $\pm 5\%$

ASSEMBLY INSTRUCTIONS



Fine Furniture for every stage of life

Side Chair

ASSEMBLY INSTRUCTIONS

ASSEMBLY TIPS:

1. Remove hardware from box and sort by size.
2. Please check to see that all hardware and parts are present prior to start of assembly.
3. Please follow attached instructions in the same sequence as numbered to assure fast & easy assembly.



WARNING!



1. Don't attempt to repair or modify parts that are broken or defective. Please contact the store immediately.
2. This product is for home use only and not intended for commercial establishments.







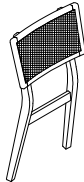
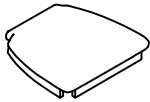
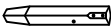
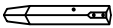

ASSEMBLY TIME

5 MINUTES

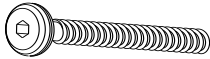
PARTS IDENTIFICATION

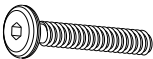
A	BACK FRAME		1PC	B	SEAT CUSHION WITH FRAME		1PC
C	LEFT FRONT LEG		1PC	D	RIGHT FRONT LEG		1PC
E	LEFT SIDE STRETCHER		1PC	F	RIGHT SIDE STRETCHER		1PC

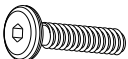
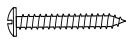
HARDWARE IDENTIFICATION

1	LONG BOLT ($\Phi 1/4$ " x 75mm - RBW)		4PCS	5	FLAT WASHER ($\Phi 1/4$ " - RBW)		10PCS
2	MEDIUM BOLT ($\Phi 1/4$ " x 60mm - RBW)		4PCS	6	ALLEN WRENCH (M4 x 60MM - RBW)		1PC
3	SHORT BOLT ($\Phi 1/4$ " x 45mm - RBW)		2PCS	7	PAN HEAD SCREW ($\Phi 4$ x 40MM - RBW)		4PCS
4	LOCK WASHER ($\Phi 1/4$ " - RBW)		10PCS				

NOTE:

Phillips head screw driver is required in the assembly process; however, manufacturer does not provide this item.

ASSEMBLY INSTRUCTIONS

STEP 1

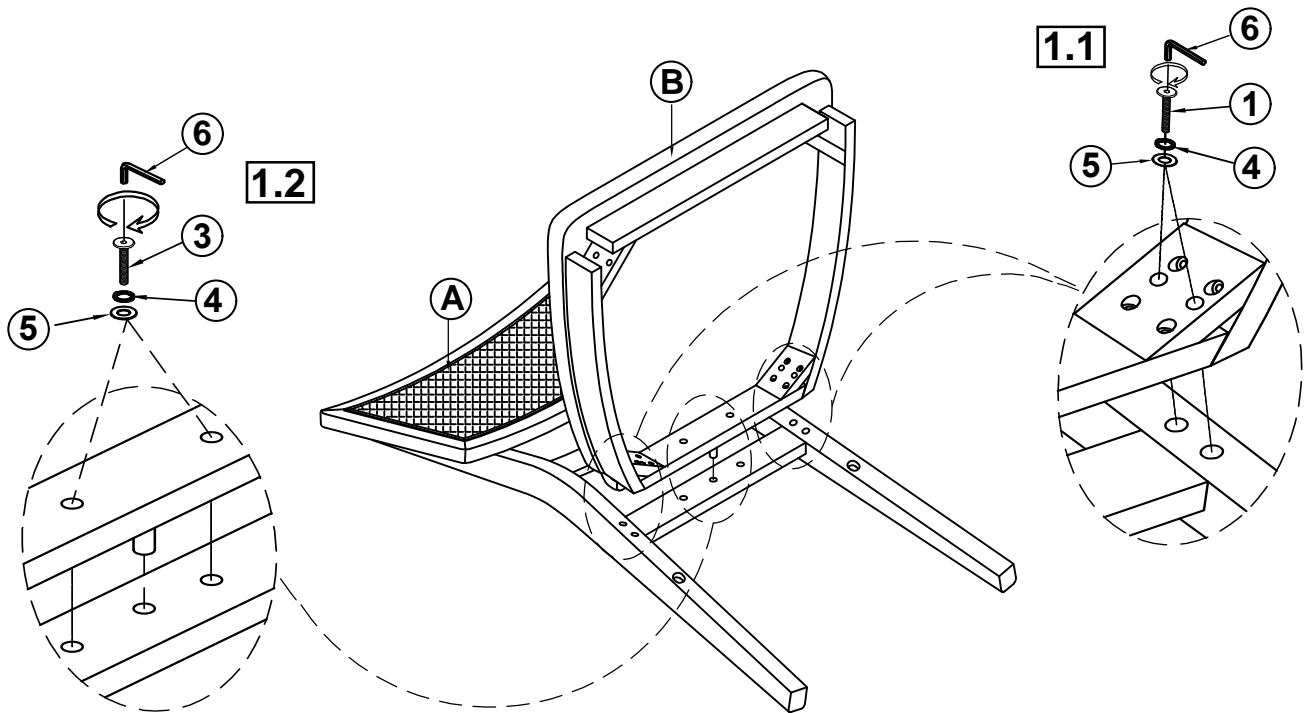

STEP 2

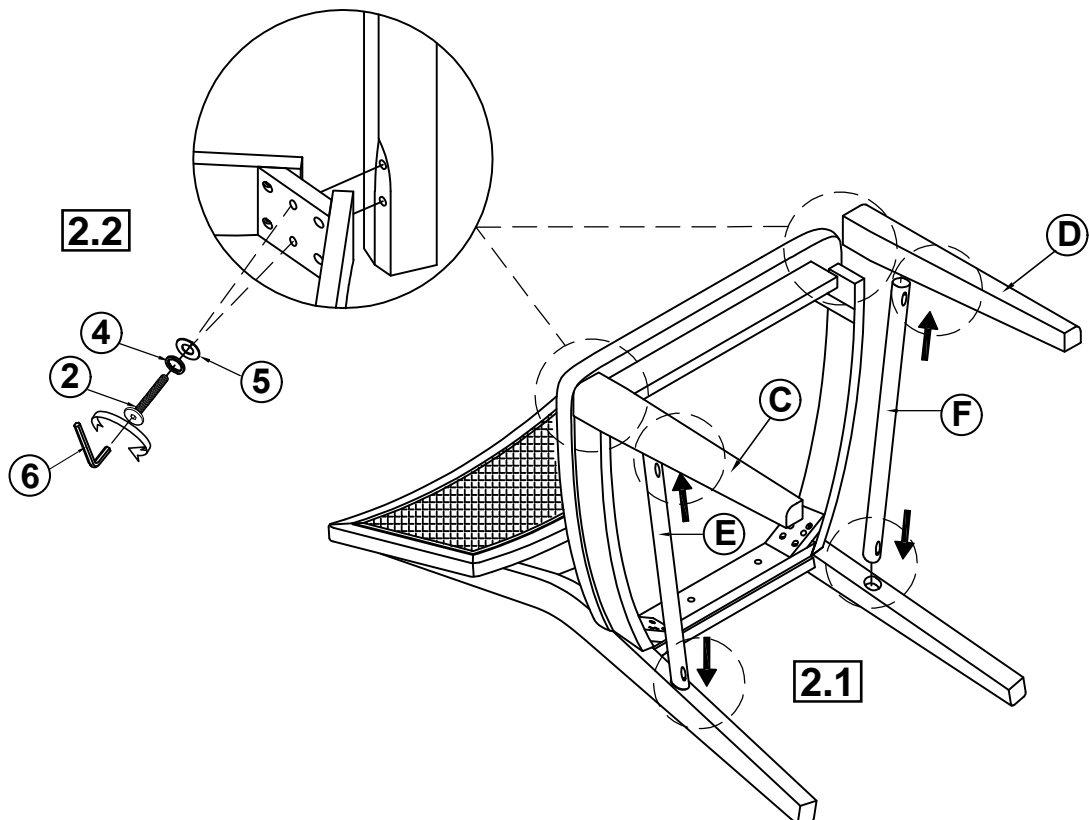

ASSEMBLY INSTRUCTIONS

STEP 3

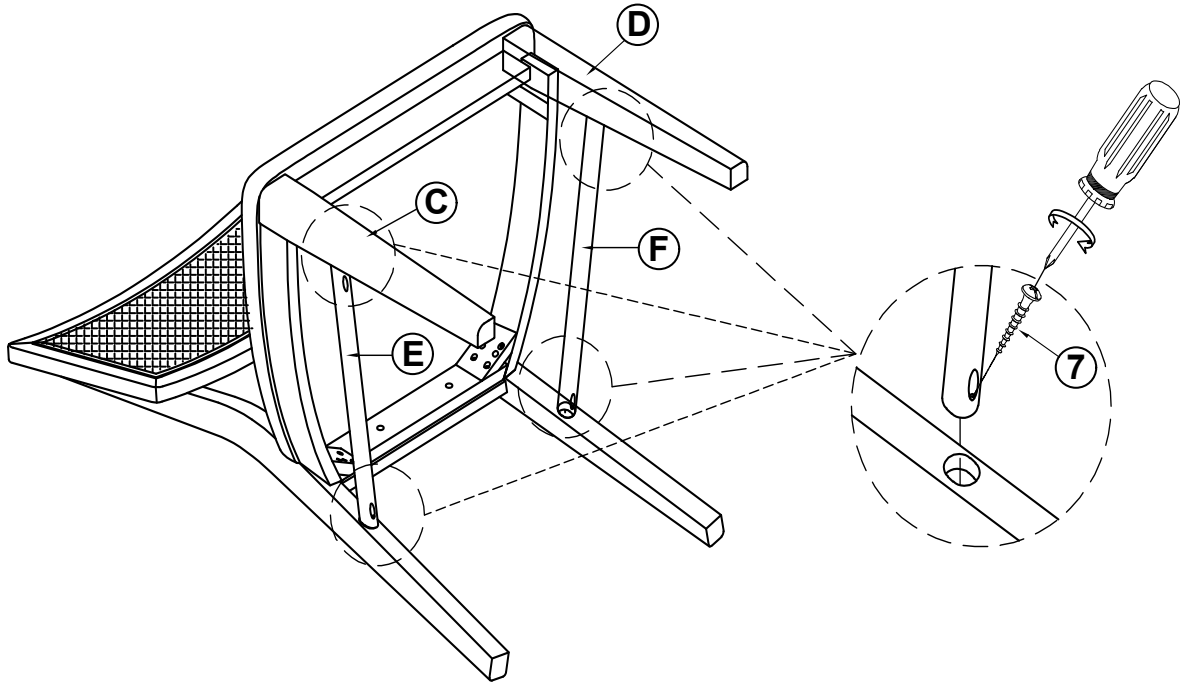

STEP 4 **COMPLETE**

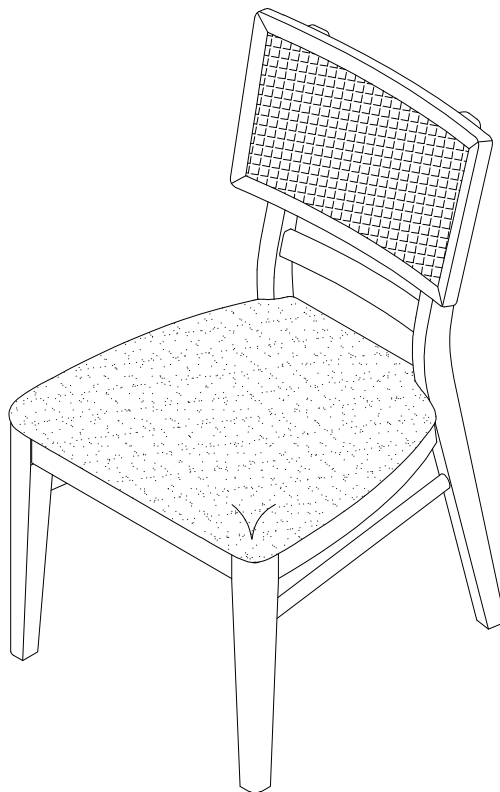

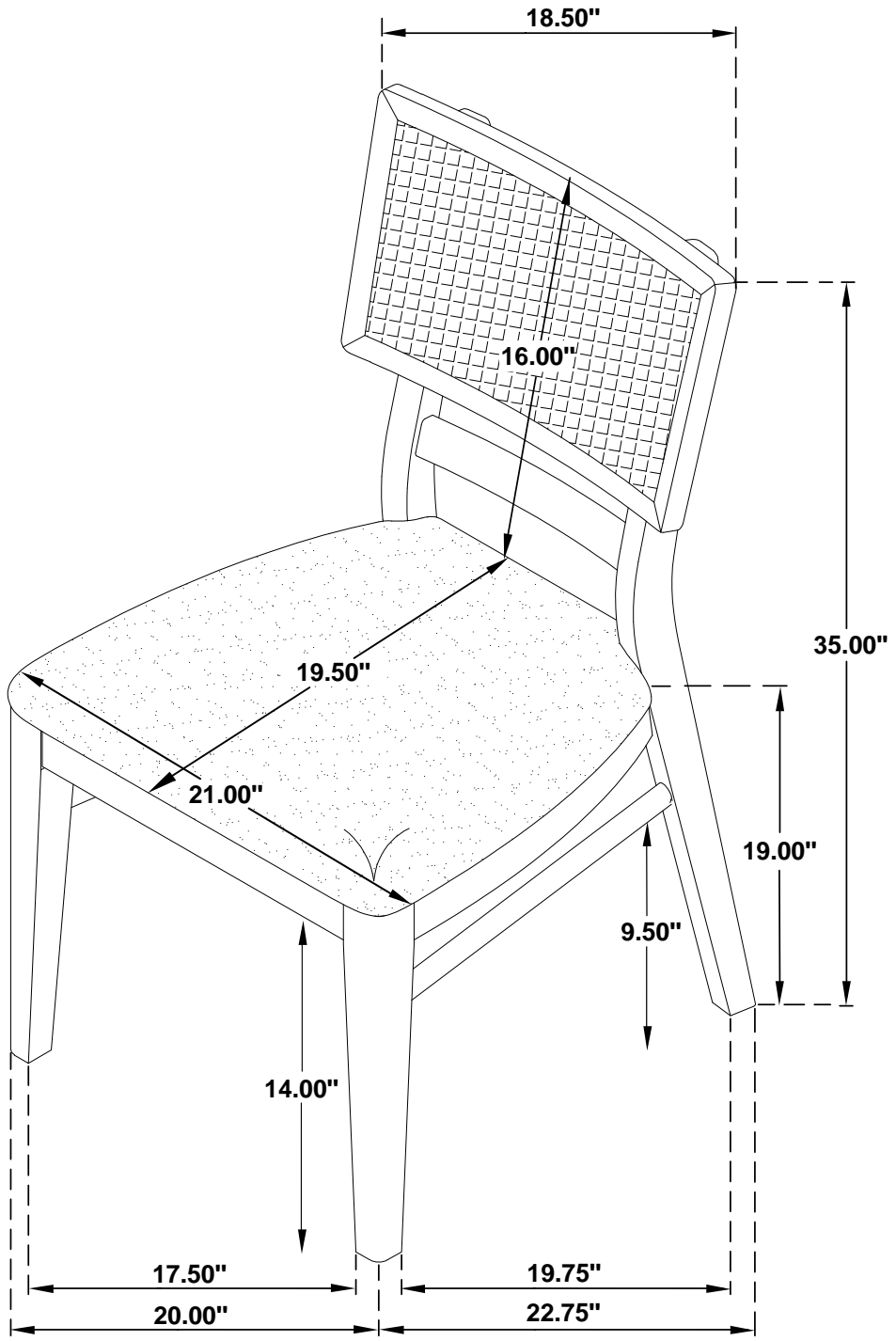

Note: Dimension tolerance $\pm 5\%$