

ASSEMBLY INSTRUCTIONS

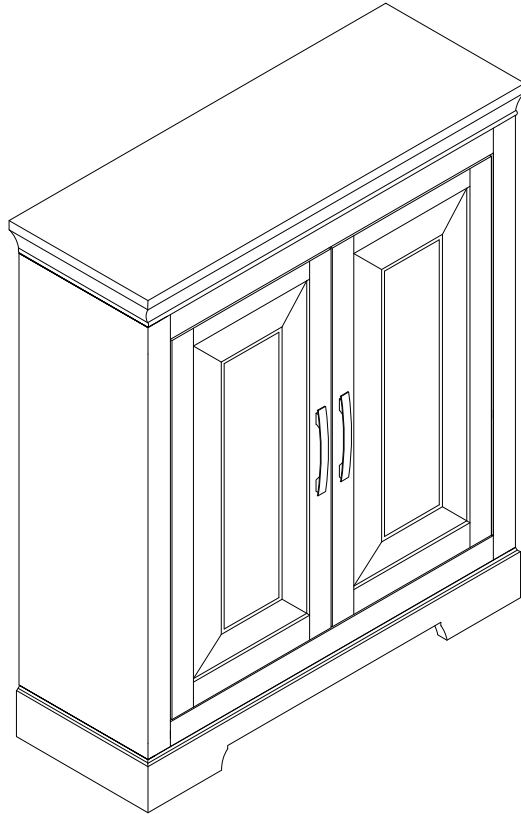

Please provide the following information when contacting for parts or questions: the name of the company you purchased from, the UPS/FedEx tracking number.

ASSEMBLY INSTRUCTIONS-IMPORTANT

Carefully unpack & identify each component before attempting to assemble. Refer to parts list. Please take care when assembling the unit and always set the parts on a clean, soft surface.

INSTRUCCIONES PARA ARMAR-IMPORANT:







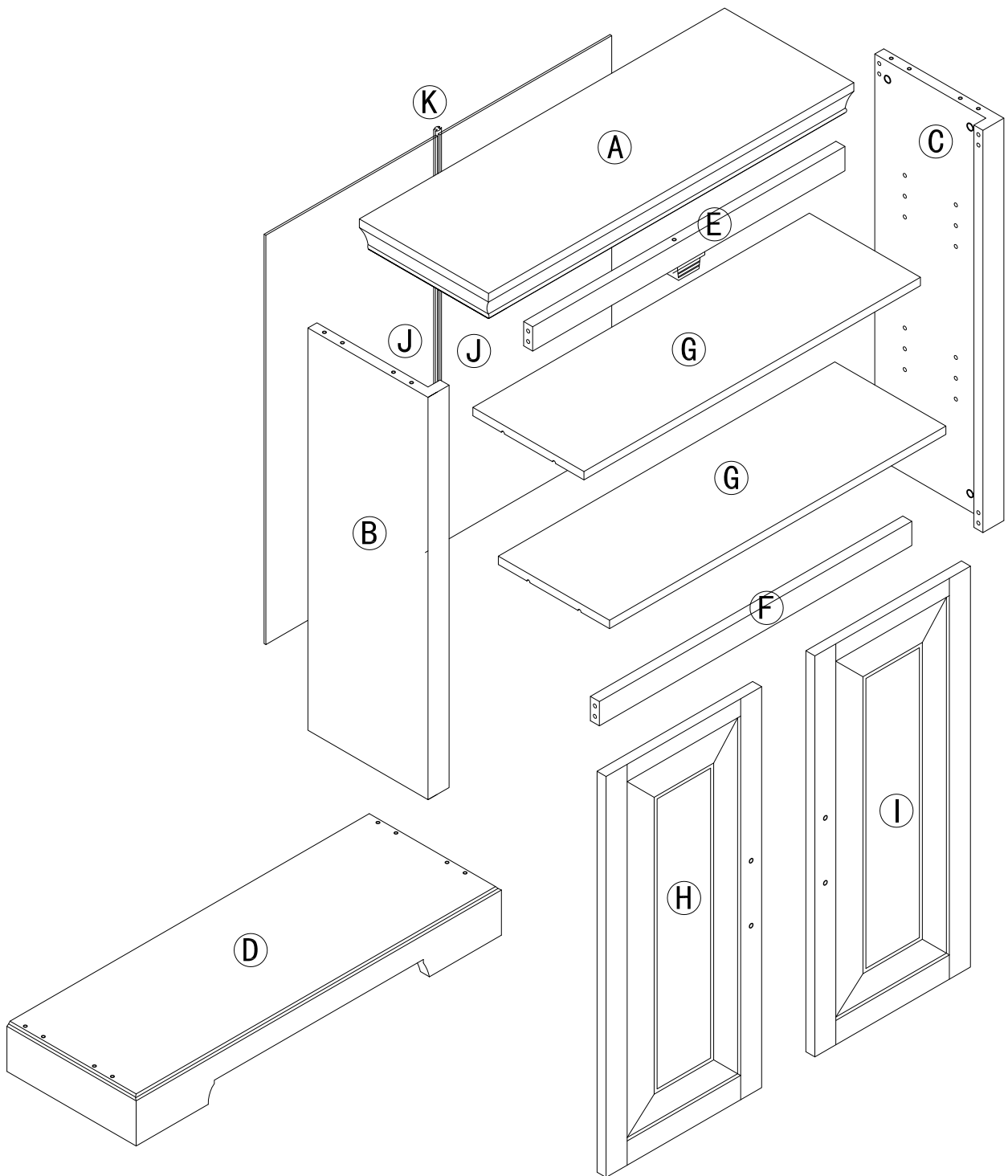



Desempaque cuidadosamente e identifique cada componente antes de tartar de empezar su ensambladura. Verifique la lista de partes. Por favor tenga cuidado cuando arme la unidad y siempre coloque las piezas sobre una superficie plana, suave y limpia.

DIRECTIVES DE MONTAGE-IMPORTANT:













Avant de commencer l'assemblage, déballez délicatement toutes les pièces et repérez-les sur la liste des pièces. Procédez avec soins durant l'assemblage et posez toujours les pièces sur une surface proper, douce et lisse.

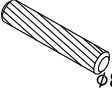

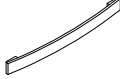
COMPONENTS

PART	FIGURE	DESCRIPTION	QTY	PART	FIGURE	DESCRIPTION	QTY
A		TOP PANEL	1PC	G		ADJUSTABLE SHELF	2PCS
B		LEFT SIDE PANEL	1PC	H		LEFT DOOR	1PC
C		RIGHT SIDE PANEL	1PC	I		RIGHT DOOR	1PC
D		BOTTOM BASE	1PC	J		BACK PANEL	2PCS
E		UPPER RAIL	1PC	K		PLASTIC BAR	1PC
F		BOTTOM RAIL	1PC				

HARDWARE & TOOLS

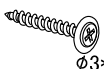
PART	FIGURE	DESCRIPTION	QTY	PART	FIGURE	DESCRIPTION	QTY
1		CAM BOLT	8PCS	8		SHELF PIN	8PCS
2	 ø15*12	CAM LOCK	8PCS	9	 ø4*35	SCREW	1PC
3	 ø8*30	WOODEN DOWEL	16PCS	10		FIX BELT	1PC
4		HANDLE	2PCS	11		WASHER	2PCS
5		HANDLE BOLT	4PCS	12		ANCHOR	1PC
6	 ø3*12	SCREW	8PCS	13	 ø4*25	SCREW	2PCS
7	 ø3*12 D=7	SCREW	16PCS				

TOOL NEEDED:



**PHILIPS SCREWDRIVER REQUIRED
- NOT INCLUDED**

SUGGESTION:

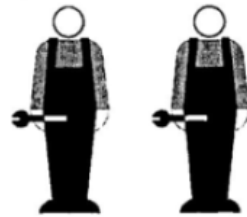

TWO PEOPLE FOR ASSEMBLING



WARNINGS:

1. DO NOT LET ANY SHARP OBJECTS TOUCH OR RUB THE SURFACE OF THE PRODUCT.
2. WHEN ASSEMBLING, DO NOT LET CHILDREN PLAY AROUND THE WORKING AREA.
3. PLEASE CONFIRM ALL PARTS ARE CORRECT BEFORE STARTING THE ASSEMBLY PROCESS.
4. DO NOT TIGHTEN ALL BOLTS AND SCREWS COMPLETELY UNTIL THE ENTIRE UNIT HAS BEEN ASSEMBLED AND SET UP.

1

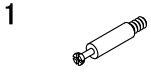

4 PCS



16 PCS

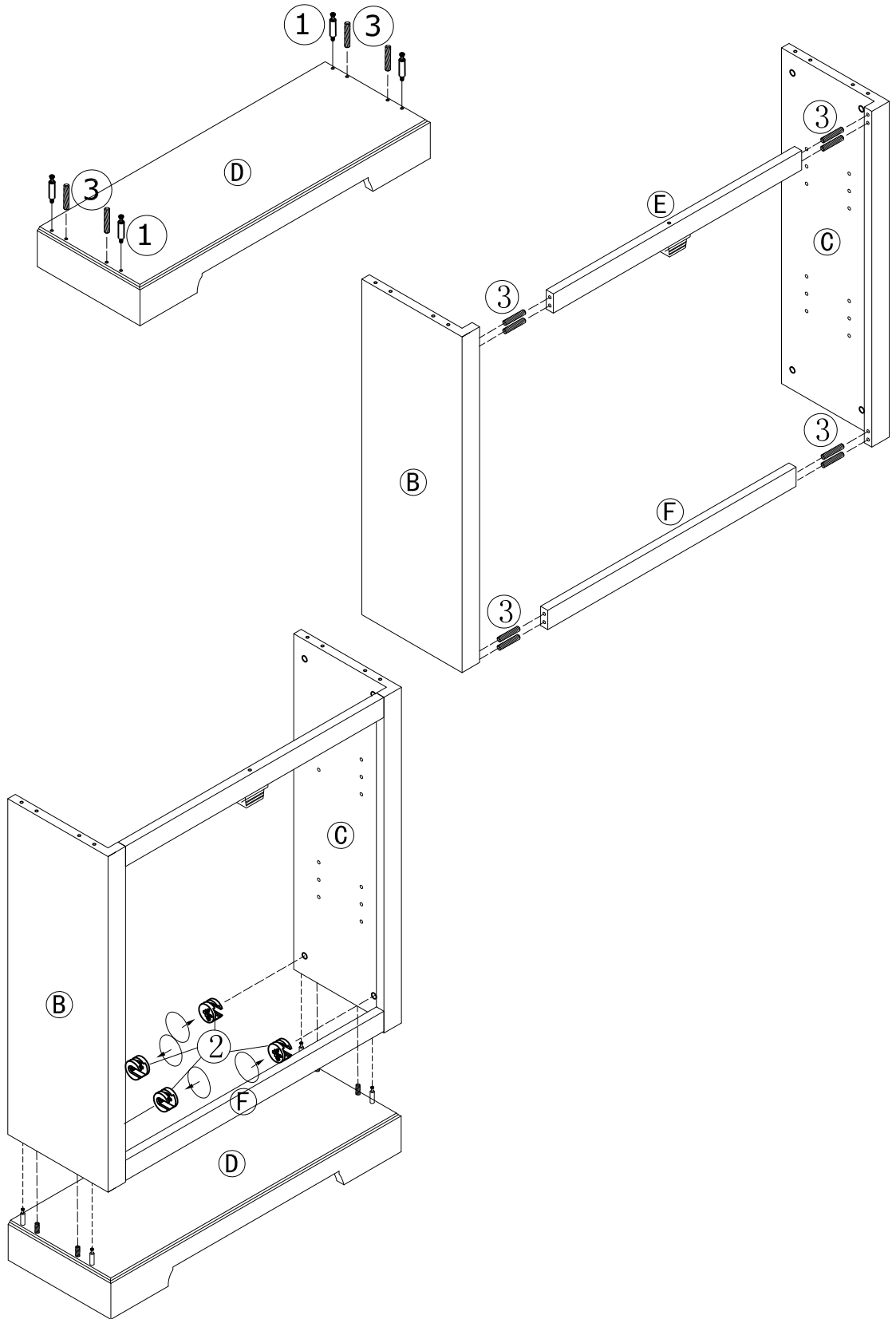

STEP 1:

1. Screw cambolts (1) and insert dowels (3) in panel D.
2. Attach panels B & C to rails E & F with dowels (3).
3. Attach panels B & C to panel D and secure with camlocks (2).

2

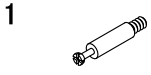

4 PCS



4 PCS



4 PCS



1 PC

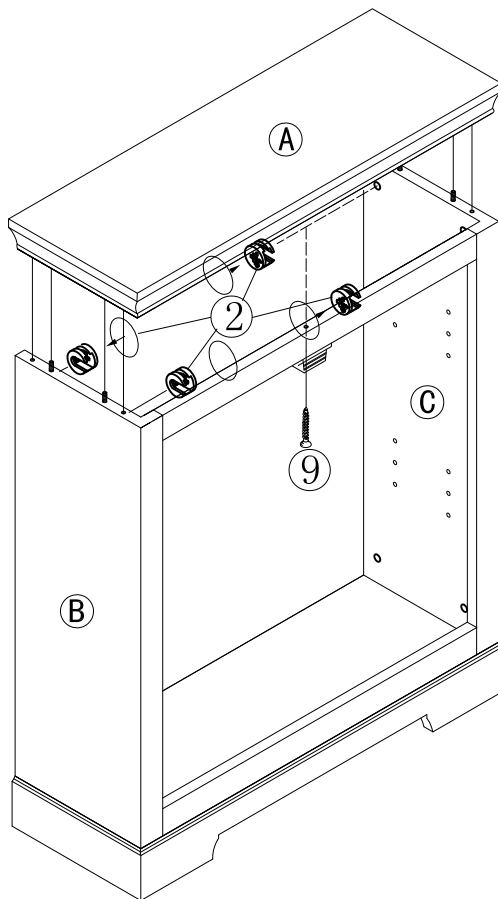
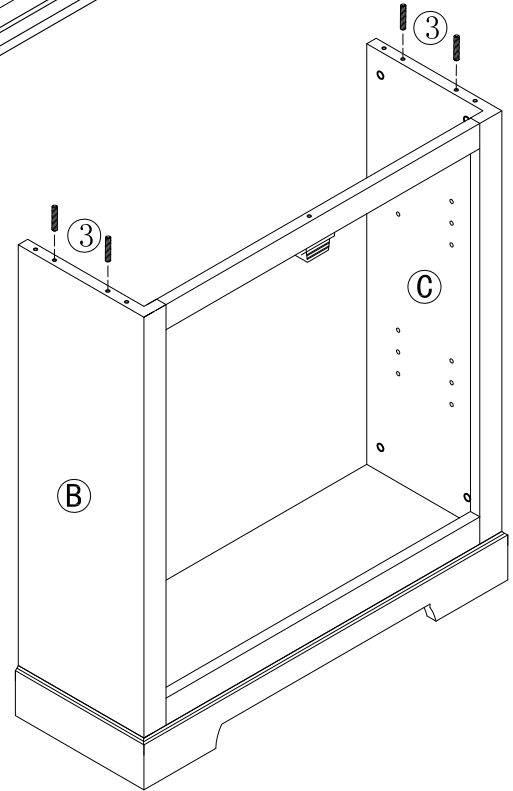
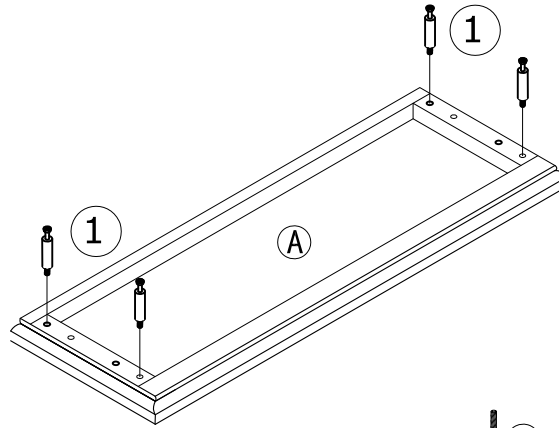

STEP 2:

1. Screw cambolts (1) into panel A.
2. Insert dowels (3) to the tops of panels B & C.
3. Attach panel A to panels B & C and secure with camlocks (2) & screw (9).

3

7



16PCS $\phi 3 \times 12$ D=7

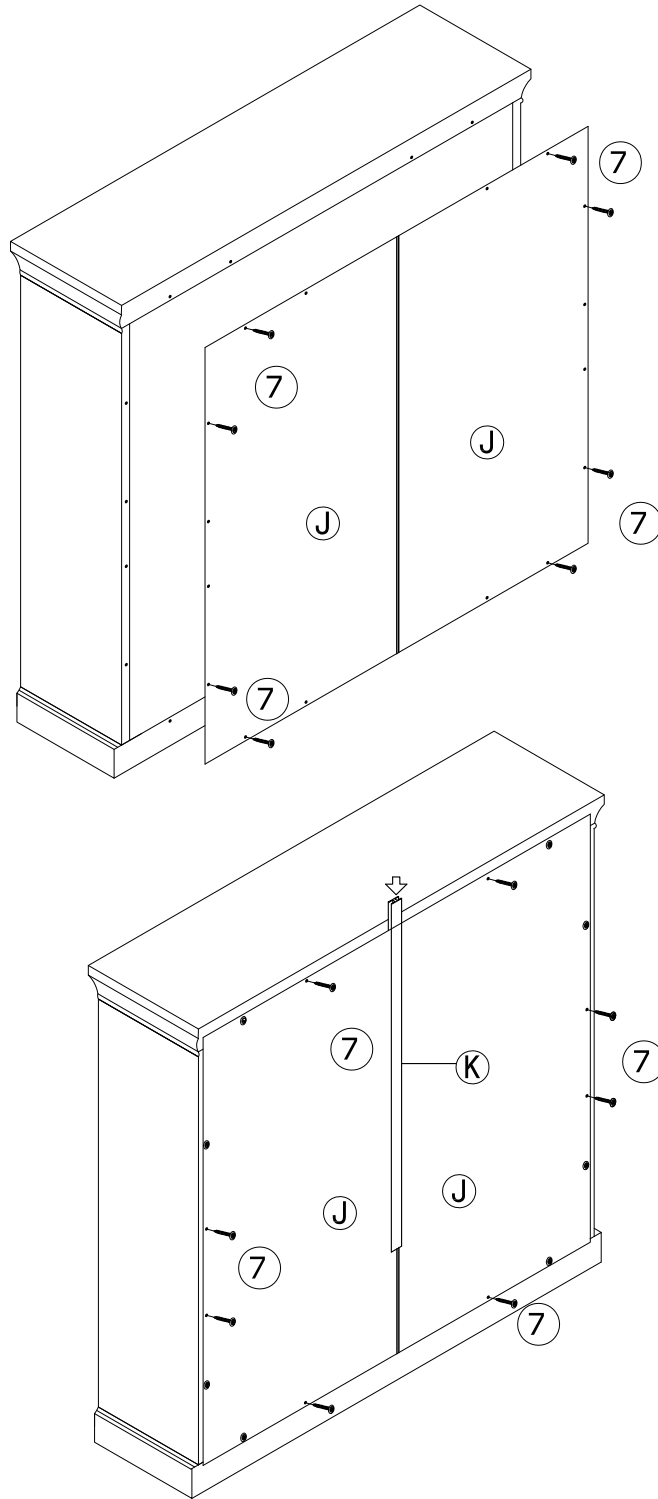

STEP 3:

1. Attach panels J to the back of the cabinet and secure the corners with screws (7).
2. Insert plastic bar K between panels J and finish securing the panels with screws (7).

4

4



2 PCS

5



4 PCS

6

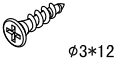

8 PCS

8



8 PCS

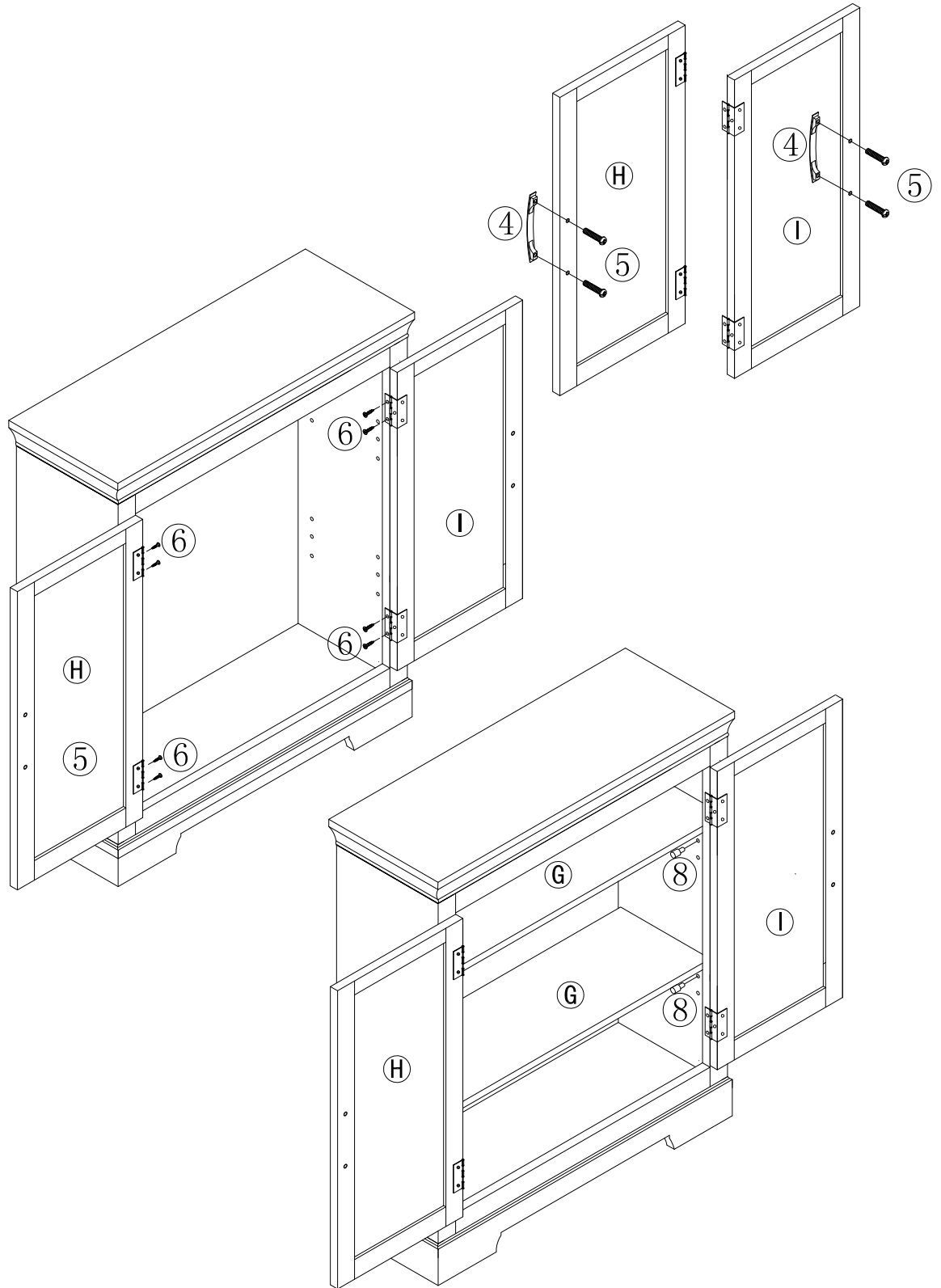

STEP 4:

1. Attach handles (4) to doors H & I with bolts (5).
2. Attach doors H & I to the cabinet with screws (6).
3. Insert shelf pins (8) into panels B & C.
4. Rest adjustable shelves G on the shelf pins.

5

10



1 PC

11



2 PCS

12



1 PC

13



2 PCS

Ø4*25

