

ASSEMBLY INSTRUCTIONS

Lewis TV Stand

ASSEMBLY

2 HOURS

2 -Person Assembly

Tools Required (Not Provided):

REQUIREMENTS

Assembly Time

(Approximate)

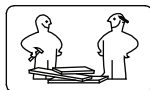

Phillips Screwdriver

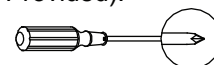

Flat Head Screwdriver

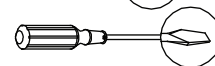

ASSEMBLY PREPARATION

1. Remove all packaging materials, staples and packing straps from the carton.
2. Refer to Parts List and Hardware List and ensure they are complete before you start assembling.
3. Place all wooden parts on a clean, flat and soft surface (e.g. carpet or rug) to prevent parts from getting scratched.

SAFETY PRECAUTION:

1. KEEP ALL HARDWARE PARTS OUT OF REACH OF CHILDREN.
2. DISPOSE PLASTIC PACKAGING MATERIAL IMMEDIATELY TO AVOID ANY RISK OF SUFFOCATION TO CHILDREN AND ANIMALS.

TIPS FOR ASSEMBLY:

1. Allow ample room for assembly and in close proximity to where product will be placed.
2. Assemble the product on a surface that does not scratch or damage the exterior gloss and finish of the furniture.
3. Please check all of the parts and quantities are included before assembly.
4. Identify all of the parts, hardware and quantities required for each step.
5. During assembly, do not over-tighten any fittings as this may cause damage.
6. DO NOT USE POWER TOOLS TO ASSEMBLE THIS PRODUCT.
7. Always place the product on a flat stable surface.
8. Do not sit or stand on the partially assembled product; only use the product for which it is intended.

CARE AND MAINTENANCE

- Use a slightly damp cloth to clean the product. Do not use bleach or abrasive cleaning material.
- Check all the fittings periodically and re-tighten as necessary. Do not use the product if any of the parts is damaged or broken.
- Never allow any kind of liquid to remain on your furniture. Absorption can cause wood to warp or delaminate.
- Do not place hot items (e.g. hot drinks) directly onto the wood surface.
- Do not drag and/or pull the furniture.







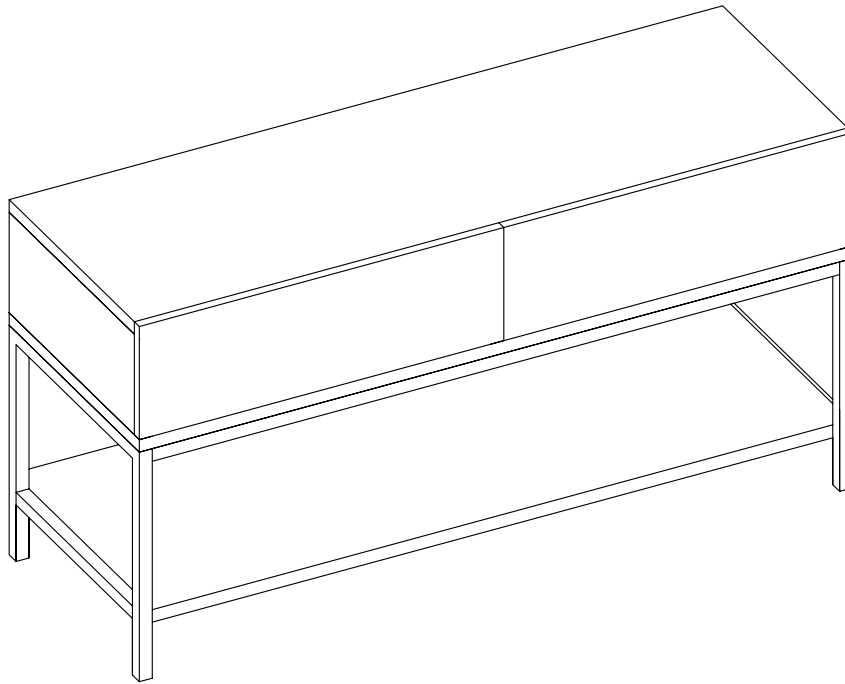

This product is for indoor and household use only - not for commercial use.

ASSEMBLY INSTRUCTIONS

TV Stand



Hardware List

ITEM	DESCRIPTION	PART	QTY	ITEM	DESCRIPTION	PART	QTY
A	Cam-lock	 14*11mm	30PCS	E	Allen Wrench		1PC
B	Cam-bolt	 5*40 mm	30PCS	F	Screw	 4*12 mm	16PCS
C	Flat Washer	 6*16 mm	28PCS	G	Metal Glide		2 sets
D	Allen-Head Bolt	 6*15 mm	28PCS	H	Screw	 4*35mm	8PCS

CAM-BOLT and CAM-LOCK INSTRUCTIONS

CAM-LOCK



Align the arrow of the Cam-lock to the Cam-bolt head and insert the Cam-lock.

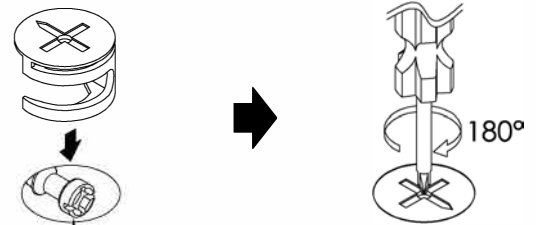
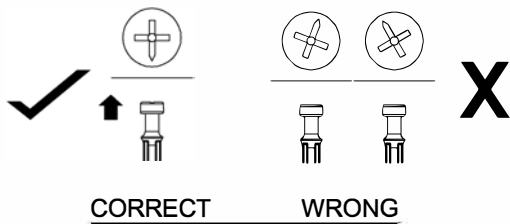

Use a flat screwdriver to turn the Cam-Lock clockwise one half a turn so it locks onto the head of the Cam-lock. Turn only until it is snug – over-tightening could damage Cam-lock or/and Cam-bolt

CAM-BOLT



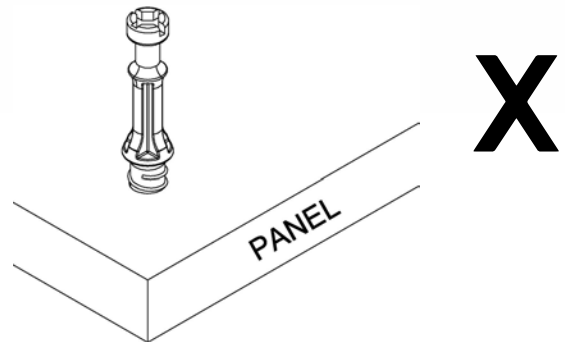
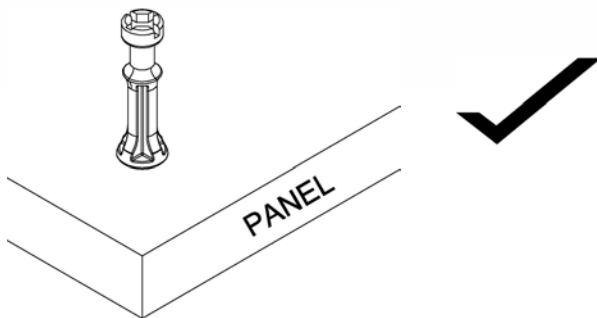
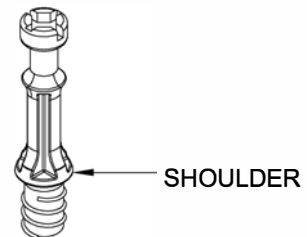

Insert Cam-bolt into the pre-drilled hole. Use a Phillips Screwdriver to tighten until shoulder is flush with the panel. See illustrations below.

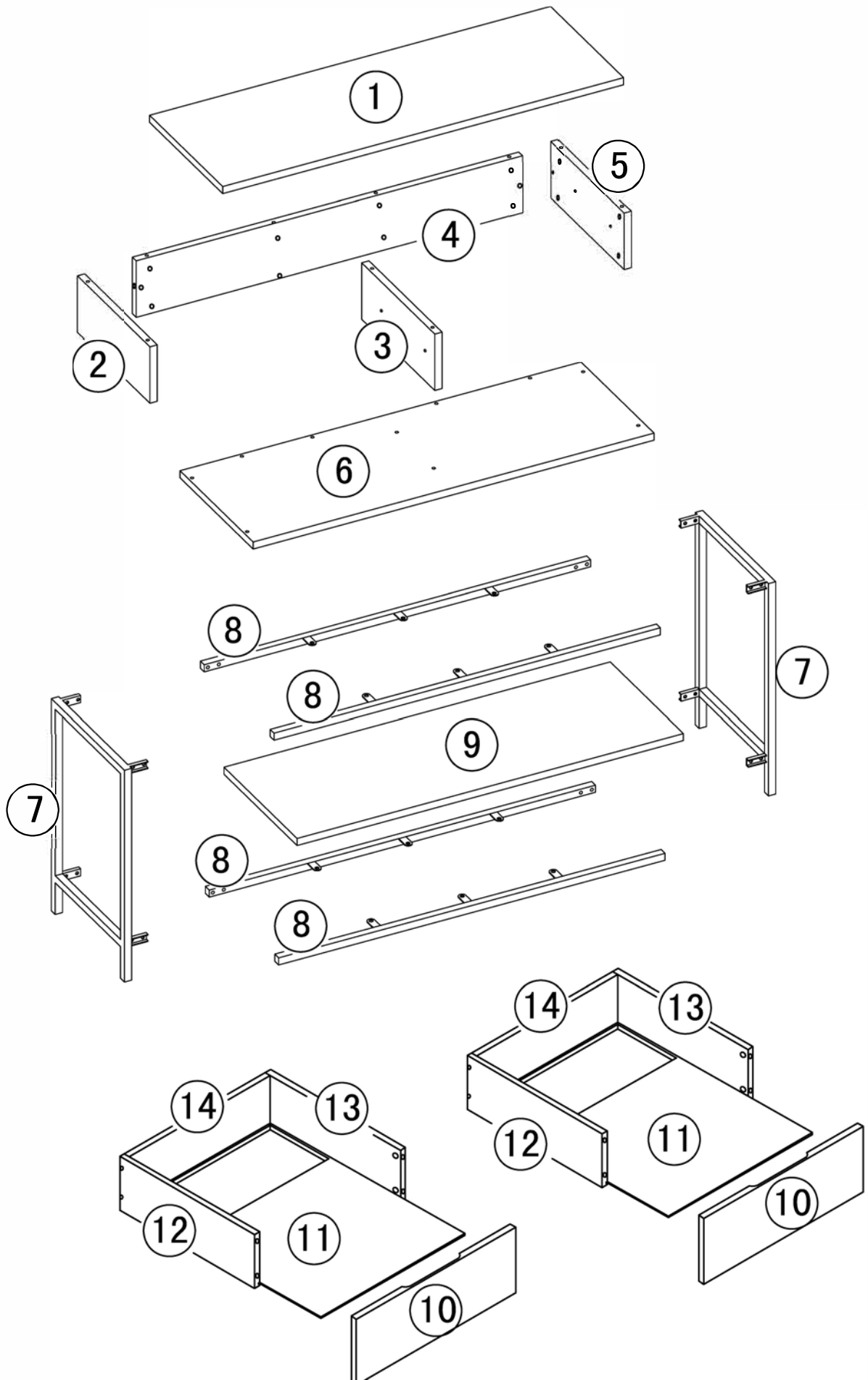

Parts & Assembly Overview

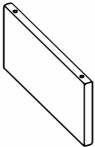
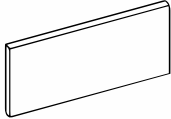
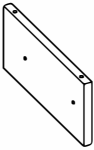
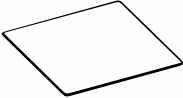
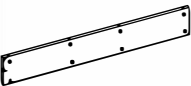
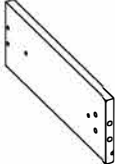
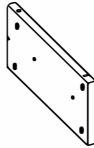
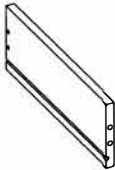
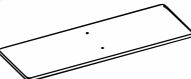
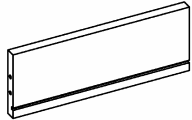

Parts List

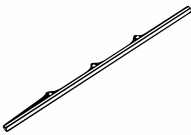
ITEM	DESCRIPTION	PART	QTY	ITEM	DESCRIPTION	PART	QTY
1	Top Panel		1PC	9	Foot Panel		1PC
2	Left Side Panel		1PC	10	Drawer Front Panel		2 PCS
3	Divide Panel		1PC	11	Drawer Bottom Panel		2 PCS
4	Back Panel		1PC	12	Drawer Left Side Panel		2 PCS
5	Right Side Panel		1PC	13	Drawer Right Side Panel		2 PCS
6	Bottom Base		1PC	14	Drawer Back Panel		2 PCS
7	Leg		2 PCS				
8	Connect Base		4 PCS				

STEP 1

1. Distinguish Metal Glide (G) between Part A and Part B.

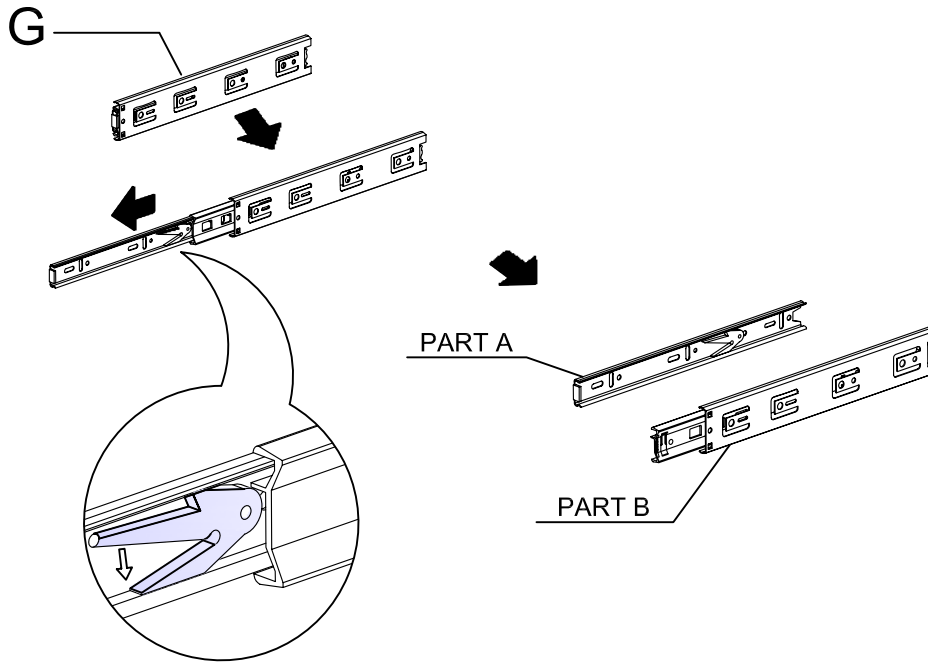

G		2 sets
---	---	--------



Push Lever downwards to slide out Part A

X 4

STEP 2

A		8 pcs
B		8 pcs

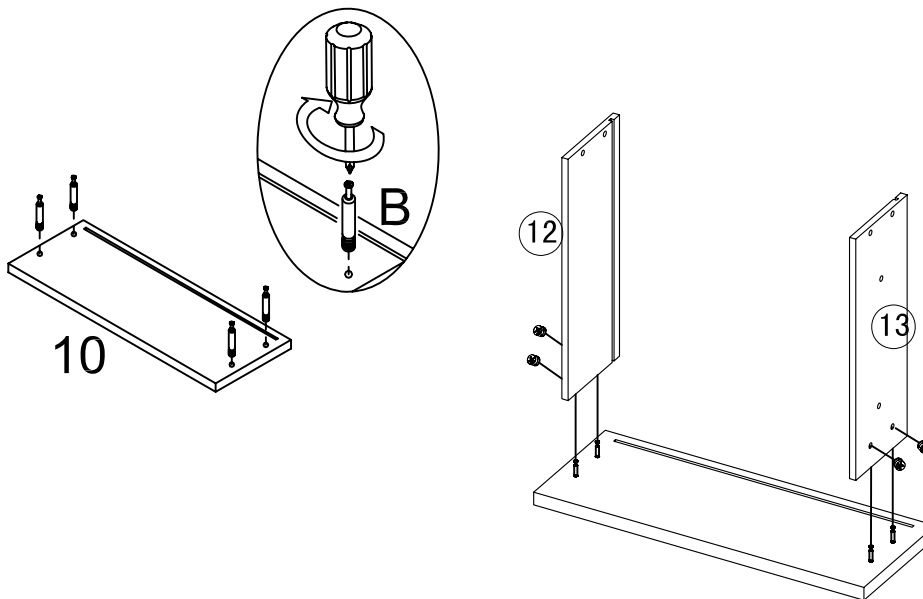

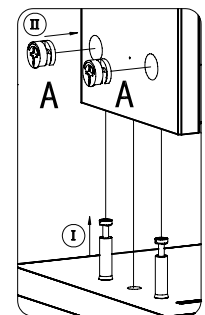

DO NOT USE POWER TOOLS



1. Attach Cam-bolt (B) to Drawer Front Panel (10).
(Refer to page on Cam-bolt and Cam-lock Instructions)
2. Attach Drawer Front Panel (10). Next, insert Cam-lock (A) then turn clockwise to lock Cam-bolt in place. (Refer to page on Cam-bolt and Cam-lock Instructions.)

X 2

STEP 3

H		8 pcs
---	---	-------

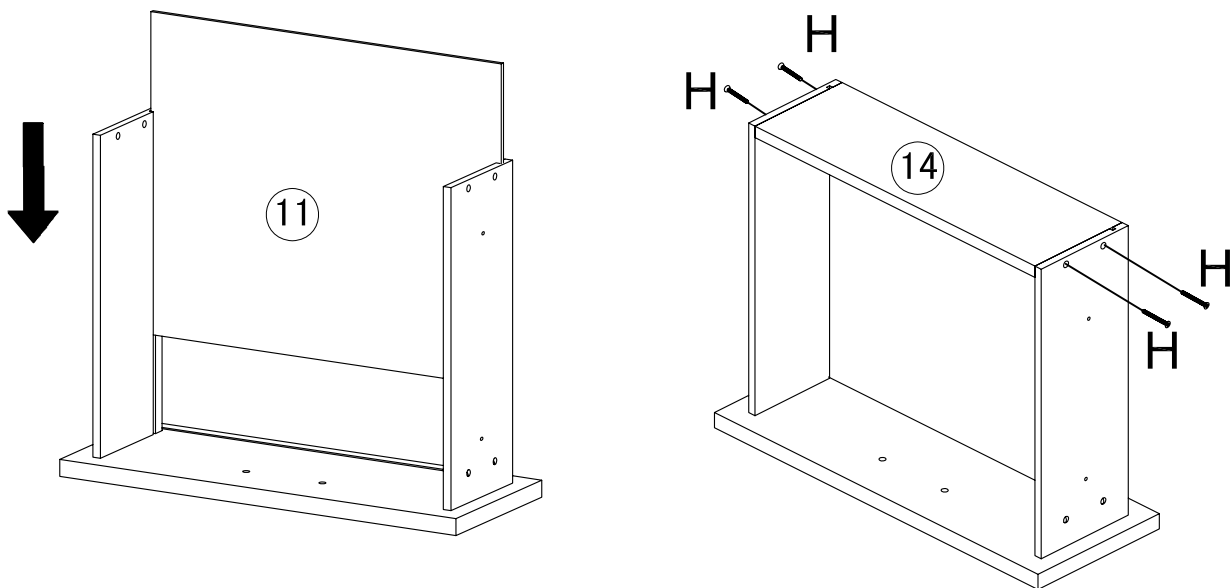

1. Insert Drawer Bottom Panel (11) by fitting (11) into the groove on Drawer Front & Side Panels.

2. Attach Drawer Back Panel (14) to Drawer Side Panel (12 & 13) by using Screw (H).

(Check that Bottom Panel (11) fits into the groove on Back Panel before fastening)

X 2

STEP 4

F		8 pcs
---	---	-------

METAL GLIDE
PART A



DO NOT USE POWER TOOLS

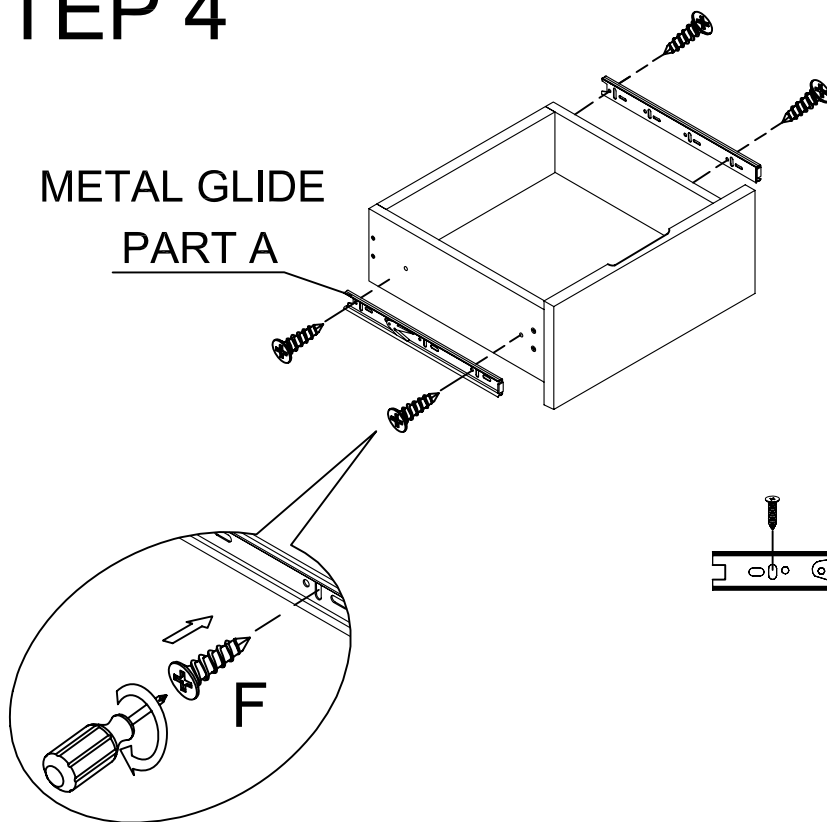



PART A

X 2

1. Install Part A of Metal Glide (G) to pilot holes on drawer by using Screw (F).

STEP 5

F		4 pcs
B		2 pcs

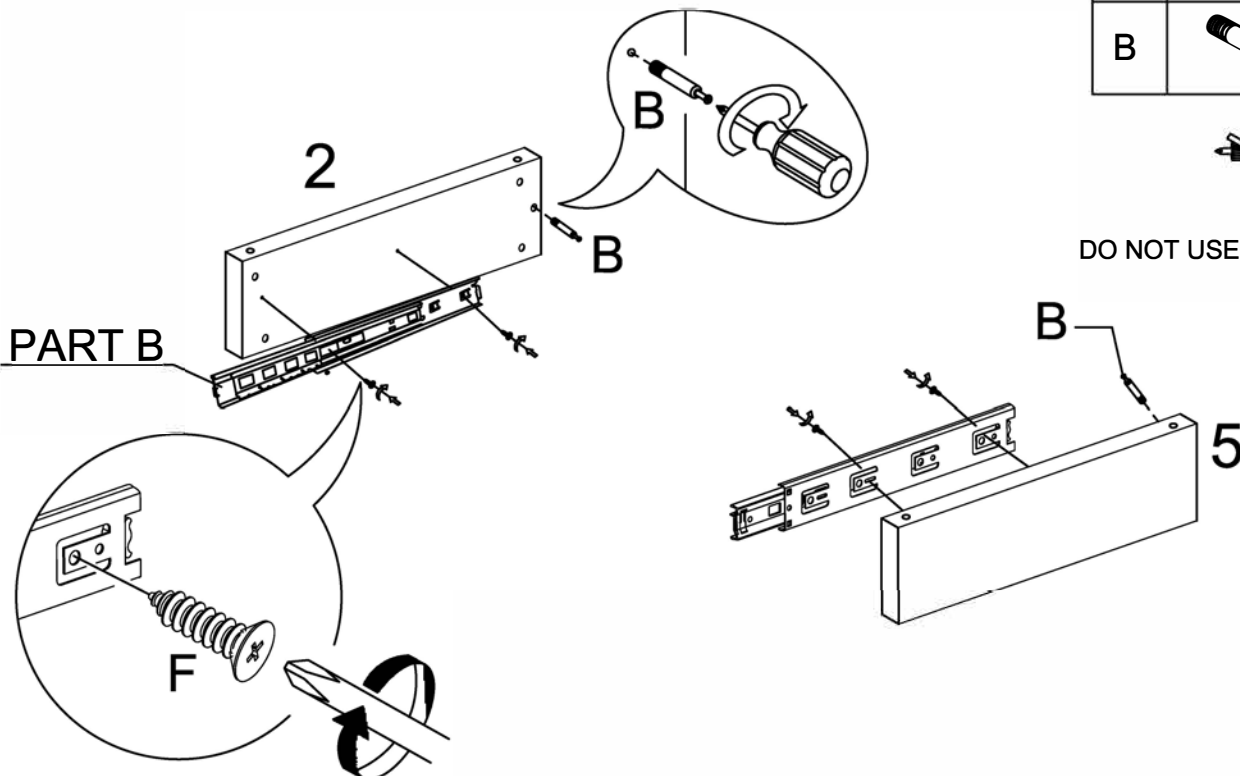

DO NOT USE POWER TOOLS

1. Install Part B of Metal Glide (G) to Left Side Panel (2) and Right Side Panel (5) by using Screw (F) .
2. Screw in Cam-bolt (B) to Left Side Panel (2) and Right Side Panel (5) (Refer to page on Cam-bolt and Cam-lock Instructions.)

STEP 6

A		2 pcs
---	---	-------

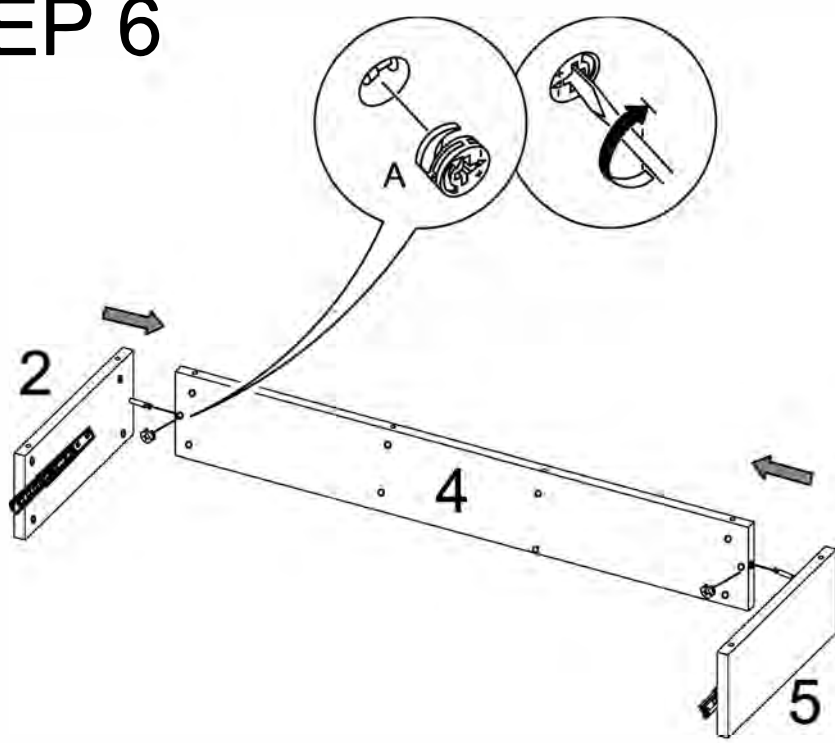

DO NOT USE POWER TOOLS

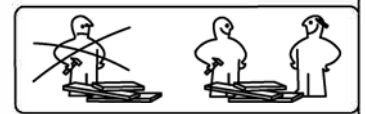

1. Attach Side Panels (2 & 5) to Back Panel (4), insert Cam-lock (A) then rotate clockwise to secure Cam-bolt in place. (Refer to page on Cam-bolt and Cam-lock Instructions.)

STEP 7

A		10 pcs
B		10 pcs

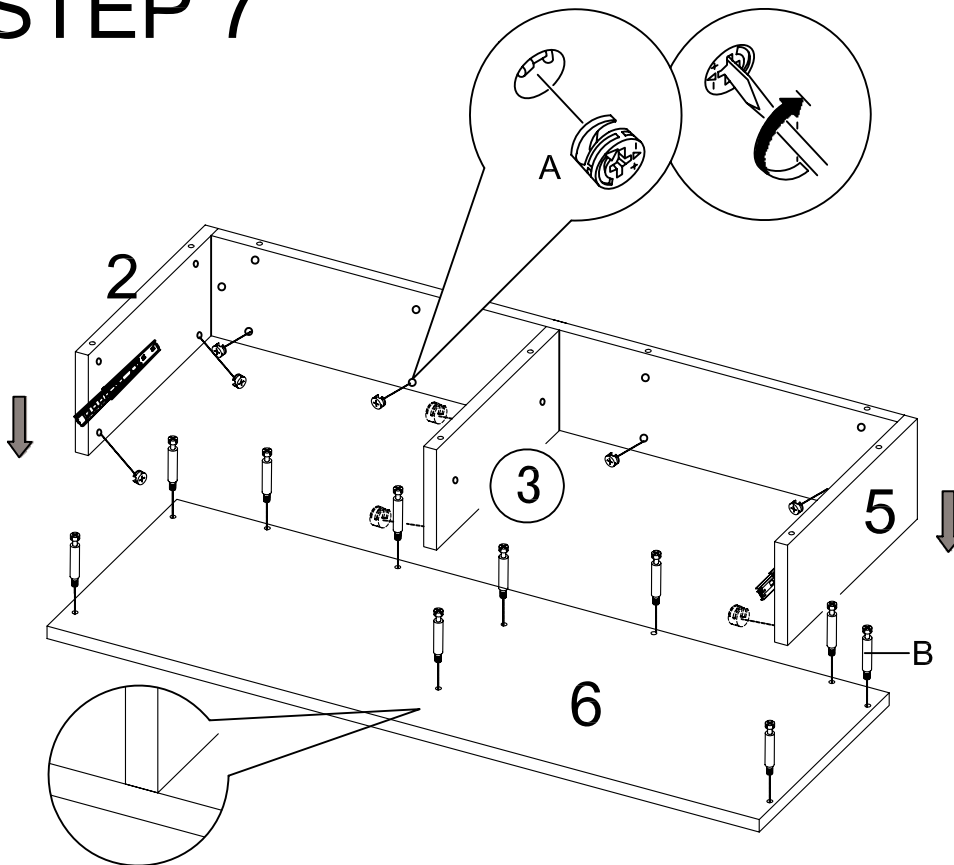

DO NOT USE POWER TOOLS

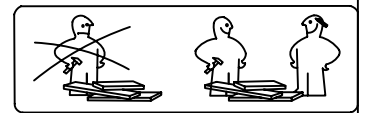

Refer to page on Cam-bolt and Cam-lock Instructions.

1. Attach Cam-bolt (B) to all of the pre-drilled holes on Bottom Base (6).
2. Install Panel (2), (4) & (5) from Step 6 and Divide Panel (3) to Bottom Panel (6). Secure with Cam-lock (A).

STEP 8

F		4 pcs
---	--	-------



DO NOT USE POWER TOOLS

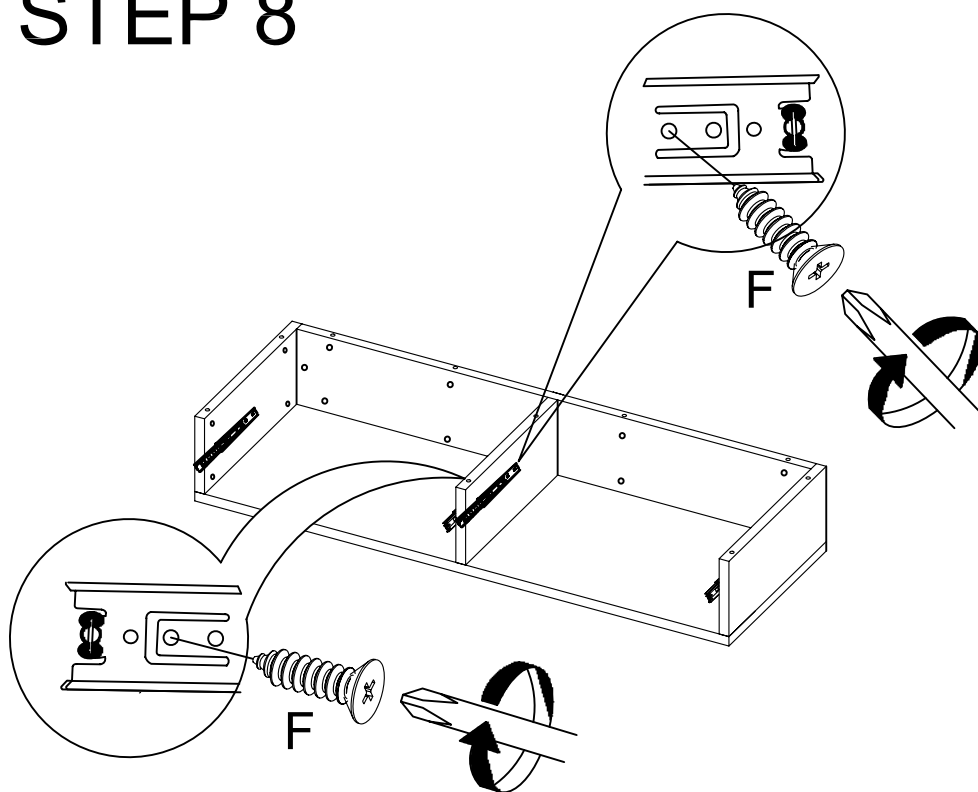
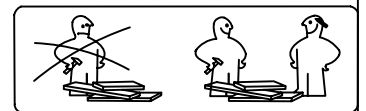

1. Install Part B of Metal Glide (G) to the left of Divide Panel (3) by using Screw (F) through the second hole.
2. Install Part B of Metal Glide (G) to the right of Divide Panel (3) by using Screw (F) through the third hole.

STEP 9

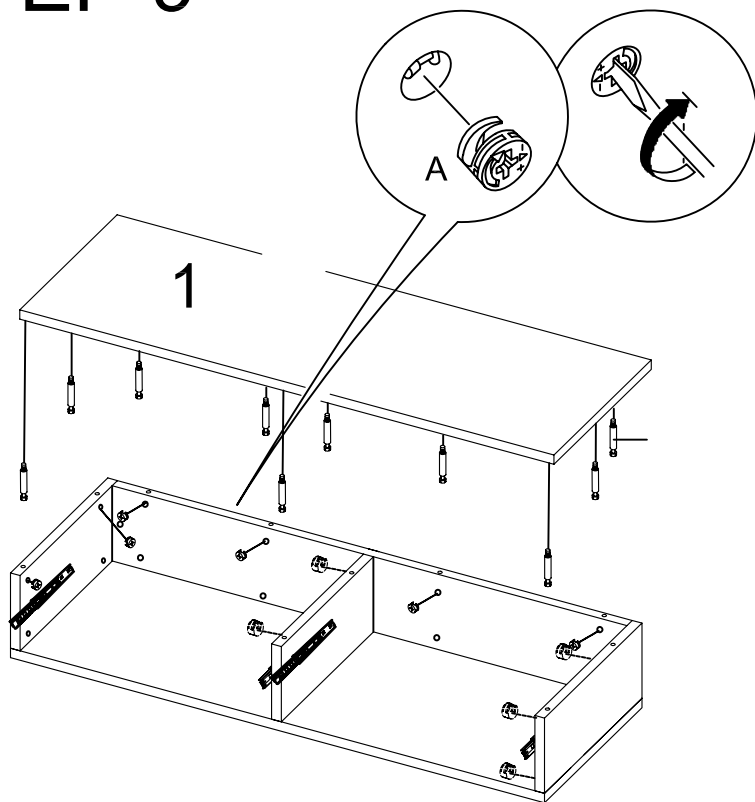

A		10 pcs
B		10 pcs

DO NOT USE POWER TOOLS

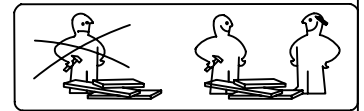

Refer to page on Cam-bolt and Cam-lock Instructions.

1. Attach Cam-bolt (B) to all of the pre-drilled holes on Top Panel (1) .
2. Install Top Panel (1) as shown. Secure with Cam-lock (A)

STEP 10

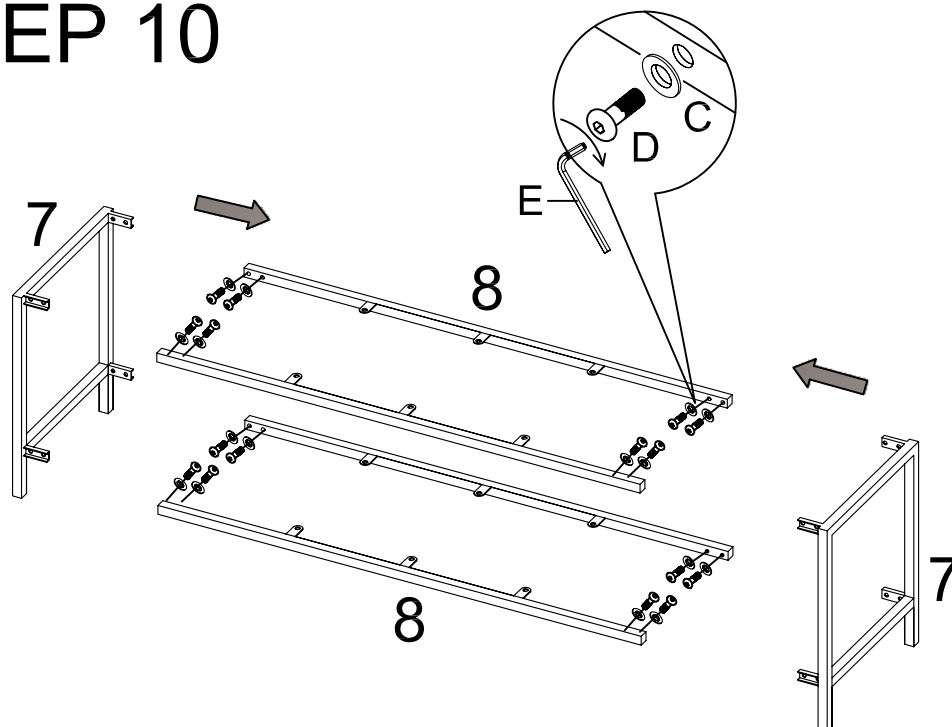

C		16 pcs
D		16 pcs
E		1pc

DO NOT USE POWER TOOLS

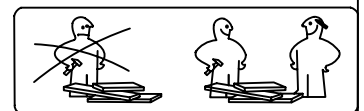

1. Attach Leg (7) to Connect Base (8) by using Allen-Head Bolt (D) and Lock Washer (C).
2. Tighten Allen-head Bolt (D) with Allen Wrench (E). Do not tighten completely until all of the Bolts are in place.

STEP 11

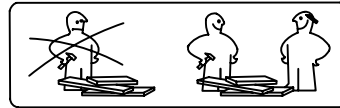

C		12 pcs
D		12 pcs
E		1pc

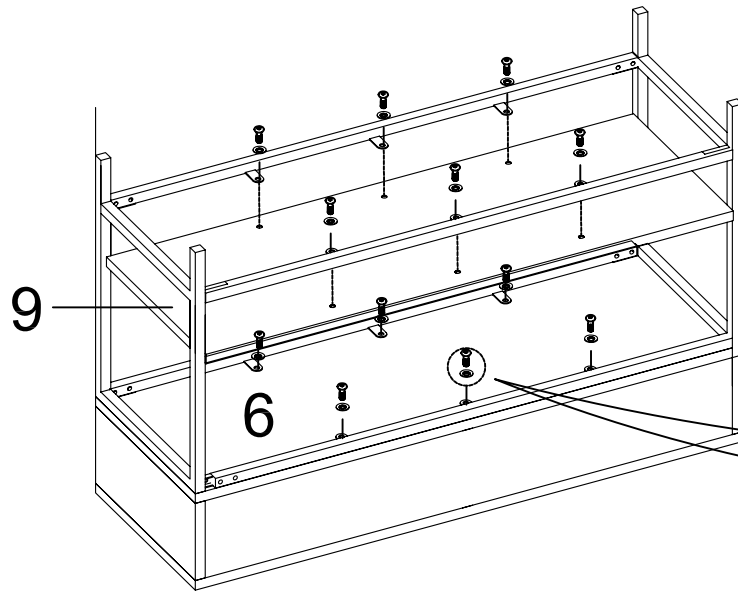

DO NOT USE POWER TOOLS

1. Place the sub-assembly completed in Step 9 bottom-side up with Bottom Base (6) face up.
2. Place Leg assembly from Step 10 bottom-side up and directly over Bottom Base (6) as shown.
3. Use Allen-Head Bolt (D) and Lock Washer (C) to attach Connect Base of Leg assembly to Bottom Base (6). Tighten the Bolt (D) by using Allen Wrench (E)
4. Position and attach Foot Panel (9) to Leg assembly as shown. Use Allen-head Bolt (D) and Lock Washer (C) to attach Foot Panel (9) to Connect Base of Leg assembly.

STEP 12

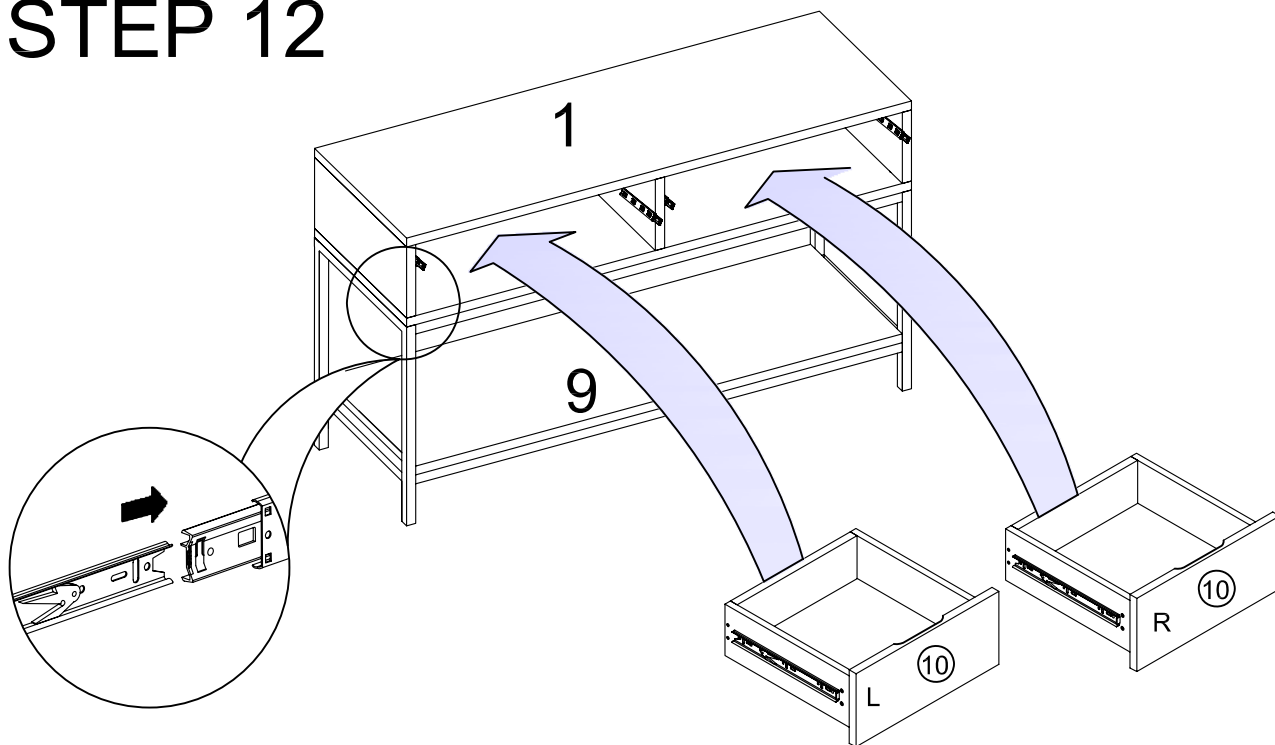

1. Insert drawers as shown.