

ASSEMBLY INSTRUCTIONS

Wave Dining Chair Item# 97118

ASSEMBLY
REQUIREMENTS

1-Person
Assembly

Assembly Time
Per Chair 30 Minutes
(Approximate)

Tools Required
(Not Provided)

 Phillips Screwdriver

 Mallet

Thank you for purchasing our product!

Please refer and use this assembly instruction to assemble the product. Contact our customer service department in case there are any missing or damage parts or hardware. Replacement parts are normally shipped within 2 or 3 days.

Email: replacementparts@buylateral.com
Within 30 days from delivery date

**PRODUCTS PURCHASED THROUGH OUR AUTHORIZED VENDORS
ONLY ARE ELIGIBLE FOR REPLACEMENT PARTS**

We appreciate your business!

**THIS PRODUCT IS FOR INDOOR AND HOUSEHOLD USE ONLY
– NOT FOR COMMERCIAL USE.**

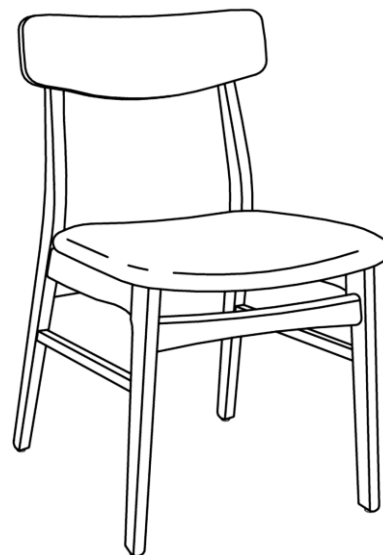

ASSEMBLY PREPARATION

1. Remove all packaging materials, staples and packing straps from the carton.
2. Refer to Parts List and Hardware List, and ensure parts and hardware are correct before assembly. Contact customer service for missing parts.
3. Place all wooden parts on a clean, flat and soft surface (e.g. carpet or rug) to prevent scratch and damage to parts.

SAFETY PRECAUTION

1. KEEP ALL HARDWARE PARTS OUT OF REACH OF CHILDREN.
2. DISPOSE PLASTIC PACKAGING MATERIAL IMMEDIATELY TO AVOID ANY RISK OF SUFFOCATION TO CHILDREN AND ANIMALS.

TIPS FOR ASSEMBLY

1. Allow ample room for assembly and in close proximity to where the product will be placed.
2. Assemble the product on a surface that does not scratch or damage the exterior gloss and finish of the furniture.
3. Identify all of the parts, hardware and quantities required for each step.
4. During assembly, do not over-tighten any fittings as this may cause damage.
5. DO NOT USE POWER TOOLS TO ASSEMBLE THIS PRODUCT.
6. Always place the product on a flat, level surface.
7. Do not sit or stand on the partially assembled product; only use the product for which it is intended.







CARE AND MAINTENANCE

- Wipe clean with a soft, dry cloth; avoid the use of harsh chemicals or household cleaners as they may damage the exterior finish of the furniture.
- Hardware may loosen over time. Periodically, check that all connections are tight; re-tighten as necessary.
- Solid wood is impacted by heat and humidity fluctuations and may result in small joint separations or hairline cracks; place the furniture away from direct sunlight and air conditioning vents, heating vents or units to protect the furniture.

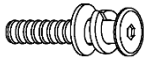
ASSEMBLY INSTRUCTIONS

Wave Dining Chair Item# 97118

HARDWARE LIST (FOR 1 CHAIR)

Item	Description	Part	Qty	Extra
A	JCBC Bolt M6x25mm + Spring Washer M6 + Flat Washer M6x13mm		4	1
B	JCBC Bolt M6x45mm + Spring Washer M6 + Flat Washer M6x13mm		4	1
C	Allen Key M4		1	
D	L Bracket		4	
E	PH CB Screw M4x12mm		8	1
F	Leg Stud 5/8" (With Pin)		4	1
G	Wood Button Ø14.5		4	1

PARTS LIST (FOR 1 CHAIR)

Item	Description	Qty
1	Right Side Frame	1
2	Left Side Frame	1
3	Front Stretcher	1
4	Back Stretcher	1
5	Back Rest	1
6	Cushion Seat	1

*EXTRA HARDWARE FOR SPARE USE

STEP 1

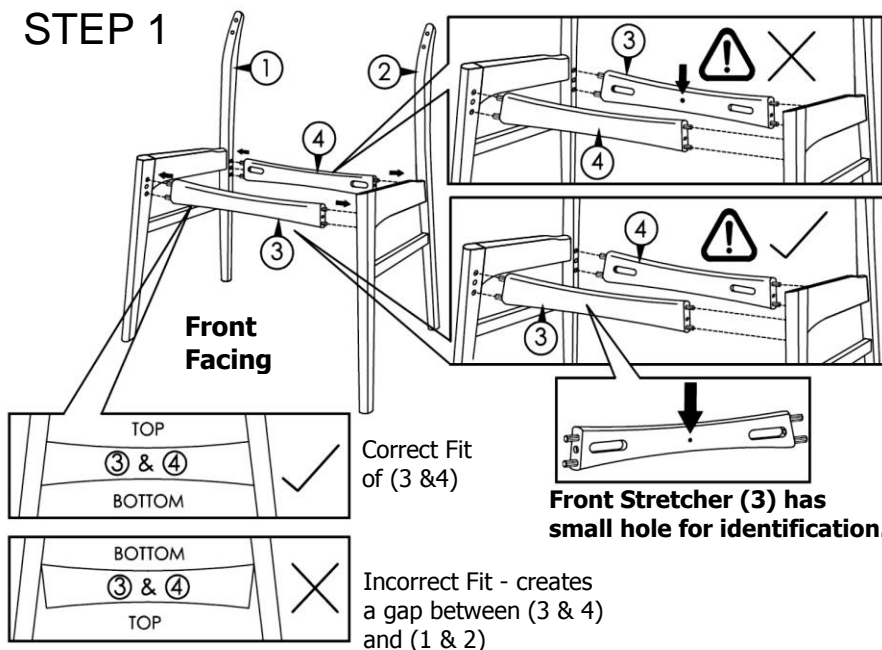

- A) Attach Front Stretcher (3) and Back Stretcher (4) to Right Frame (1) and Left Frame (2) via pre-installed wood dowels on (3) & (4).

Note:

- Be sure Front Stretcher (3) – with small hole – is attach to front position of chair.
- Refer to Correct Fit of (3 & 4) – Be sure the TOP edge (shorter edge) and BOTTOM edge (longer edge) of (3 & 4) are fitted as shown. Otherwise (3 & 4) will not fit correctly and create a gap as shown in Incorrect Fit.

STEP 2

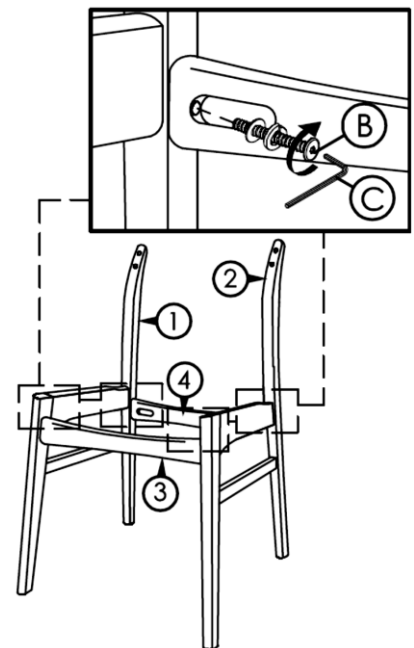

- Insert JCBC Bolt (B) fitted with Spring Washer and Flat Washer through the hole on Front Stretcher (3) and Back Stretcher (4) to screw into the hole on Right Frame (1) and Left Frame (2).
- Use Allen Key (C) to drive (B). **Do not tighten (B) completely at this time.**

ASSEMBLY INSTRUCTIONS

Wave Dining Chair Item# 97118

STEP 3

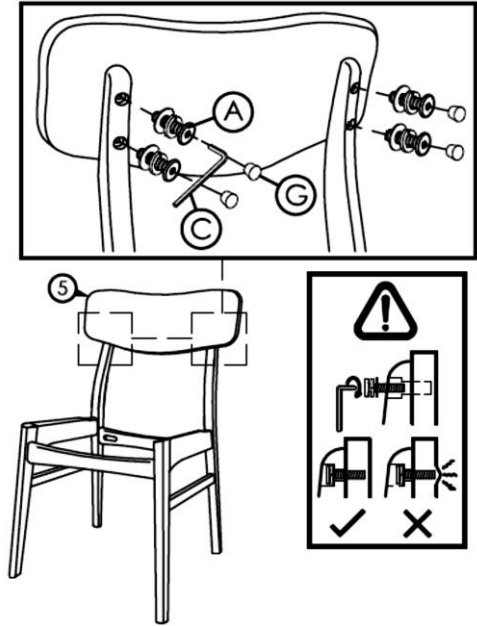

- a) Align bolt holes on Back Rest (5) to bolt holes on Right and Left Frame.
- b) Use Bolt (A) fitted with spring washer and flat washer to fasten (5) to Right and Left Frame.
- c) Use Allen Key (C) to drive (A). Do not tighten completely until all 4 screws are in place. **Do not over-tighten.**
- d) Use Wood Button (G) to conceal screw holes.
- e) Next, fully tighten all 4 Bolts (B) from STEP 2. **Do not over-tighten.**

STEP 4

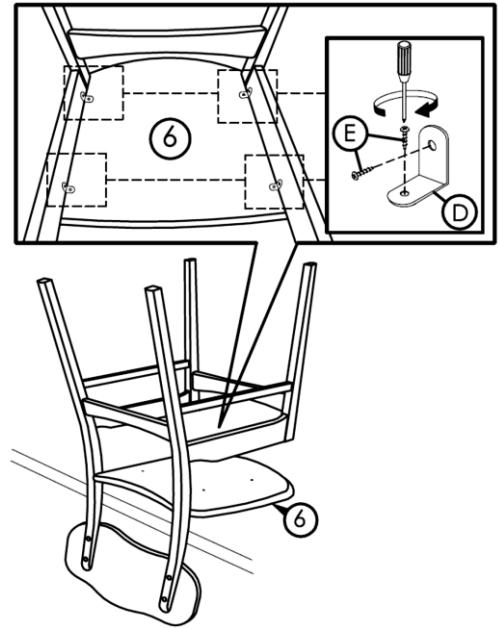

- a) Place Seat (6) bottom-side up on an elevated surface (e.g. table top).
- b) Position the chair frame assembly from STEP 3 as shown.
- c) Use Screw (E) and L-Bracket (D) to fasten (6) to Right and Left frame. Note the locations to fasten (D).

STEP 5

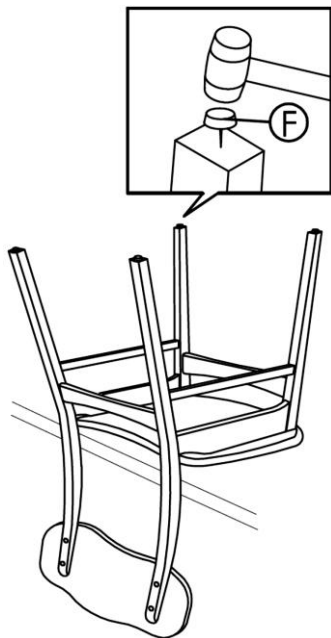

- a) Use a mallet to lightly tap in Leg Stud (F) to the bottom of each leg.

STEP 6

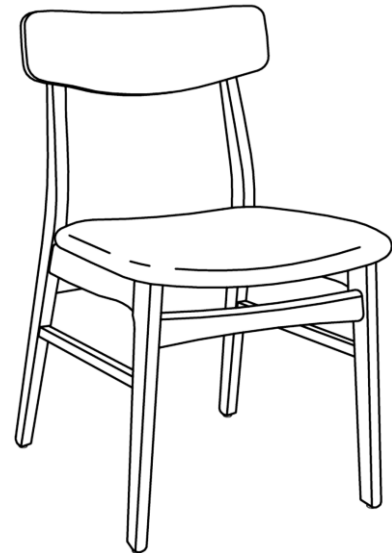

Set the chair right-side up. The assembly of the chair is complete.