

INSTRUCTION MANUAL

Electric Fireplace

FC302BK03A

FC302WH03A

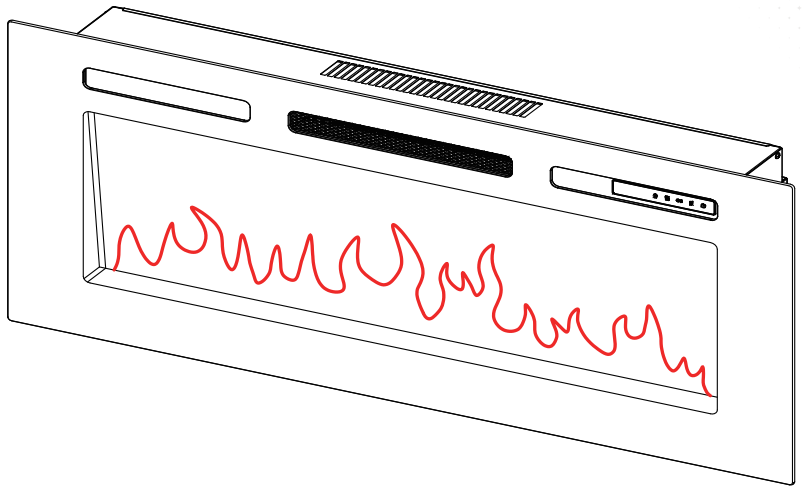

Oneinmil furniture

We are a professional furniture provider with top-notch factories and outstanding designs, Our mission is to provide consumers with new lifestyles. By collecting consumer feedback, we constantly improve our products and create more choices for consumers.

If you want to create your space,

We are an ideal choice.

————— Always. —————



WARNING

**READ AND UNDERSTAND
THIS ENTIRE OWNER'S
MANUAL, INCLUDING ALL
SAFETY INFORMATION,
BEFORE PLUGGING IN OR
USING THIS PRODUCT.
FAILURE TO DO SO COULD
RESULT IN FIRE, ELECTRIC
SHOCK, OR SERIOUS
PERSONAL INJURY.**



CAUTION

**KEEP THIS OWNER'S
MANUAL FOR FUTURE
REFERENCE. IF YOU SELL
OR GIVE THIS PRODUCT
AWAY, MAKE SURE THIS
MANUAL ACCOMPANIES
THIS PRODUCT.**



AS THIS ITEM CONTAINS MANY PARTS, PLEASE READ THE INSTALLATION INSTRUCTION CAREFULLY BEFORE INSTALLATION. PLEASE USE TOOLS PROPERLY AND CAREFULLY.

IF YOU HAVE ANY QUESTIONS ABOUT THE PRODUCT AND INSTALLATION, PLEASE CONTACT US. OUR PROFESSIONAL AFTER-SALES TEAM WILL SERVE YOU ONLINE ALL DAY.

IMPORTANT SAFETY INFORMATION!

⚠ WARNING

When using electrical appliances, basic precautions should always be followed to reduce the risk of fire, electric shock, injury to persons, and hyperthermia, including the following:

1. Read all instructions before using this heater.
2. This heater is hot when in use. To avoid burns, do not let bare skin touch hot surfaces. If provided, use handles when moving this heater. Keep combustible materials, such as furniture, pillows, bedding, papers, clothes, and curtains at least 0.9 m from the front of the heater and keep them away from the sides and rear.
3. Extreme caution is necessary when any heater is used by or near children or invalids and whenever the heater is left operating and unattended.
4. Always unplug heater when not in use. (for Portable Type)
5. Do not operate any heater with a damaged cord or plug or after the heater malfunctions, has been dropped or damaged in any manner. Discard heater, or return to authorized service facility for examination and/or repair. (for Portable Type)
6. Do not operate any heater after it malfunctions. Disconnect power at service panel and have heater inspected by a reputable electrician before reusing. (for Stationary Type)
7. Do not use outdoors.
8. This heater is not intended for use in bathrooms, laundry areas and similar indoor locations. Never locate heater where it may fall into a bathtub or other water container. (for Portable Type)
9. Do not run cord under carpeting. Do not cover cord with throw rugs, runners, or similar coverings. Do not route cord under furniture or appliances. Arrange cord away from traffic area and where it will not be tripped over. (for Portable Type)
10. To disconnect heater, turn controls to off, then remove plug from outlet. (for Portable Type)

- 11.To disconnect heater, turn controls to off, and turn off power to heater circuit at main disconnect panel (for Stationary Type).
- 12.Do not insert or allow foreign objects to enter any ventilation or exhaust opening as this may cause an electric shock or fire, or damage the heater.
- 13.To prevent a possible fire, do not block air intakes or exhaust in any manner. Do not use on soft surfaces, like a bed, where openings may become blocked. (for Portable Type)
- 14.To prevent a possible fire, do not block air intakes or exhaust in any manner. (for Stationary Type).
- 15.A heater has hot and arcing or sparking parts inside. Do not use it in areas where gasoline, paint, or flammable liquids are used or stored.
- 16.Use this heater only as described in this manual. Any other use not recommended by the manufacturer may cause fire, electric shock, or injury to persons.
- 17.Always plug heaters directly into a wall outlet/receptacle. Never use with an extension cord or relocatable power tap (outlet/power strip). (for Portable Type)
- 18.This heater may include an audible (a visual) alarm to warn that parts of the heater are getting excessively hot. If the alarm sounds (flashes), immediately turn the heater off and inspect for any objects on or adjacent to the heater that may cause high temperatures. **DO NOT OPERATE THE HEATER WITH THE ALARM SOUNDING (FLASHING).**
- 19.Hyperthermia can result in death. Symptoms of hyperthermia include high body temperature, headache, nausea, vomiting, tiredness, dizziness, fainting, and rapid pulse. If you begin to experience symptoms related to hyperthermia, turn off the heater and seek medical attention. (for Portable Type)
- 20.To avoid excessive room temperatures which can cause hyperthermia: **DO NOT** leave product running unattended in a confined space around infants, or individuals with reduced physical, sensory, or mental capabilities. (for Portable Type)
- 21.This heater is for use on 120 volts. The cord has a plug as shown at A in Figure below. An adapter as shown at C is available for connecting three-blade grounding-type plugs to two-slot receptacles. The green grounding lug extending from the adapter must be connected to a permanent ground such as a properly grounded outlet box. The adapter should not be used if a three-slot grounded receptacle is available.

Grounding methods

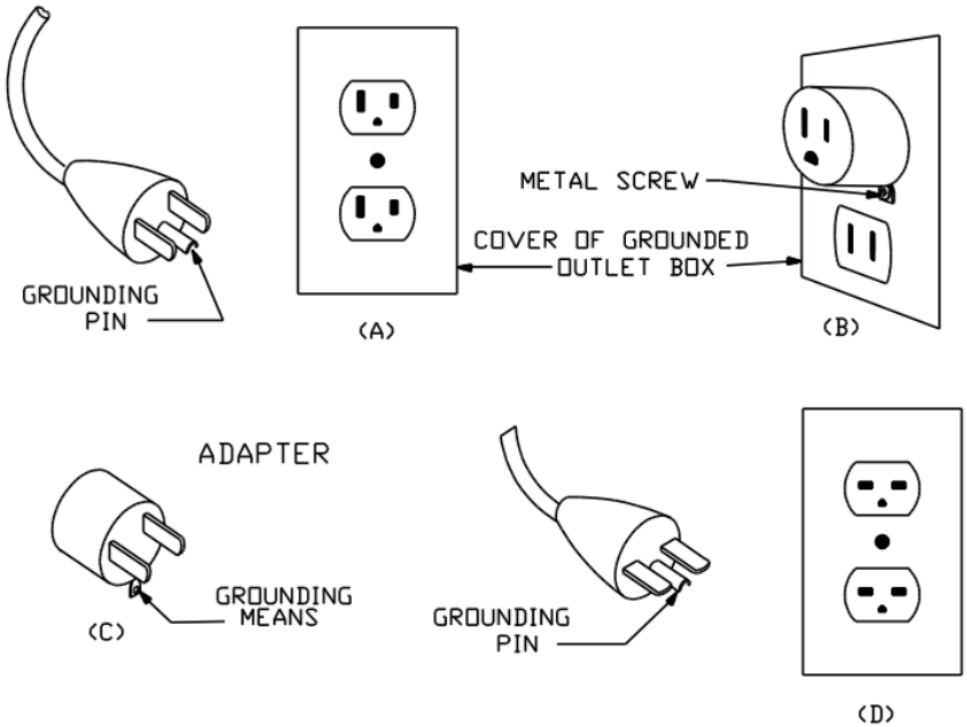

NOTE: Adaptors are NOT for use in Canada.

22.SAVE THESE INSTRUCTIONS.

TECHNICAL SPECIFICATIONS

Model No.:EF565A

Supply Voltage: AC120V 60Hz

Maximum power consumption:1500W

Power for flame and fuel bed effect:11.40W

Power for backlight effect:5.76W

TOOLS REQUIRED



PHILLIPS
SCREWDRIVER



DRILL &
NO.6 DRILL BIT



PENCIL
& RULER

+ AAA - 2 AAA BATTERIES



LEVELER



2Persons Assembly



Minimum 30 Minutes For Assembly

PARTS & HARDWARE

- Unpack the fire carefully, make sure that the appliance is intact with no signs of damage caused by transport and no part has been exposed to water. If in doubt, do not use the appliance and contact an authorized service center.
- Keep plastic wrapping away from children.
- Save the original packaging as this may be required in the event of service complaint with product.
- Check that all parts are removed from the packaging.

A

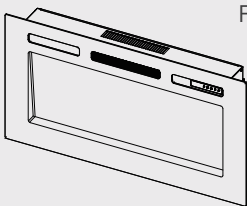

Fireplace

1PC

B

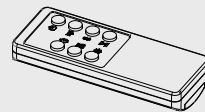

Remote Control

1PC

C

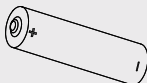

AAA Battery

2PCS

D

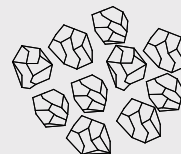

Decorative Crystals

1set

E

ST4x12 Screw



4 PCS

F

Backlight Strip



2 PCS

G

Backlight Strip Bracket

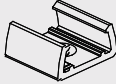

2 PCS

H

Decorative Crystals



1 set

I

Connecting Wire

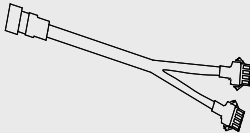

1 PC

APPLIANCE DIMENSIONS

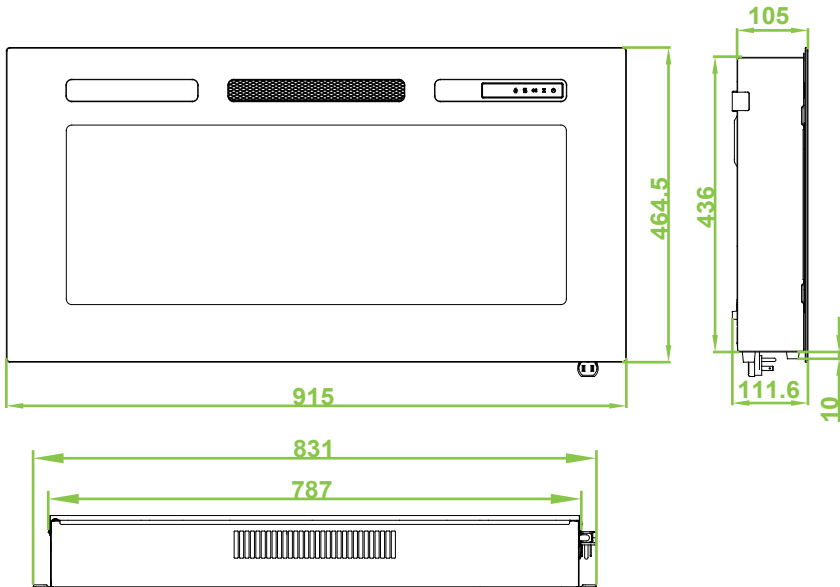

INSTALLATION INSTRUCTIONS

Tools Required

A screw driver will be needed.

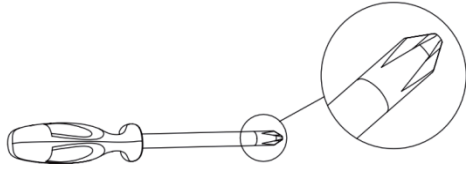

Locating the Appliance

Your new electric fireplace may be installed virtually anywhere in your home. However, when choosing a location ensure that the general instructions are followed.

- 1.1 For best result, install out of direct sunlight.
- 1.2 The appliance should be connected to an earthed electrical outlet and it must be easily accessible to allow disconnection.

Prepare the Electrical Supply

- Plan the location of the appliance so that it will have adequate electric power. A 15 AMP, 60Hz circuit is required for 120V installation. The appliance should ideally be located close to a suitable main socket to enable power connection.
- Always make sure the outlet is in good condition and the plug is not loose. NEVER exceed the maximum amperage of the circuit.

Installing the Appliance

1. Remove the four screws pointed by arrows as shown in the below pictures.

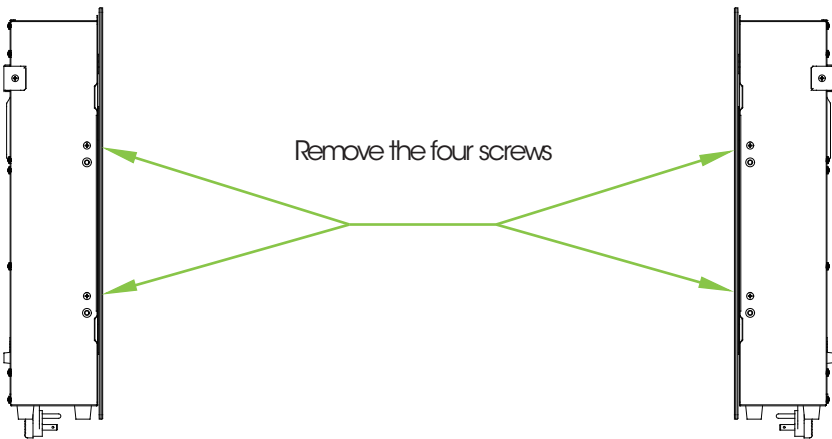
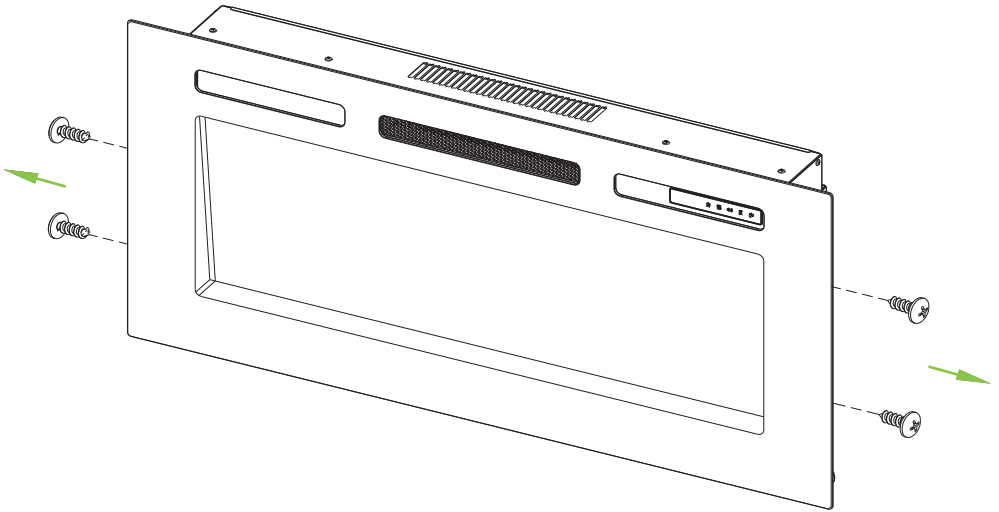

Installing the Appliance

2. Remove the glass panel carefully and take out the backlight strips inside the fireplace.

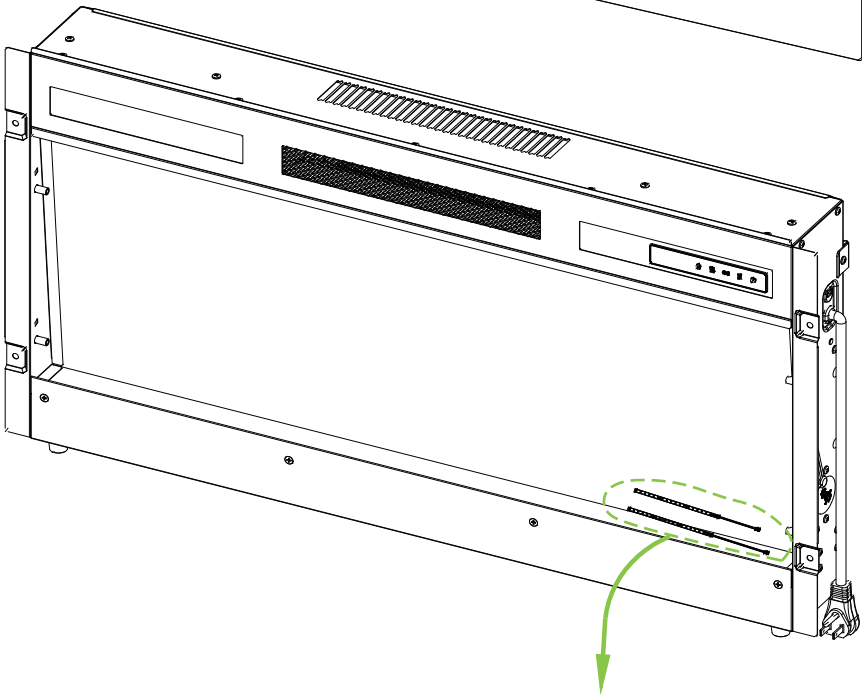
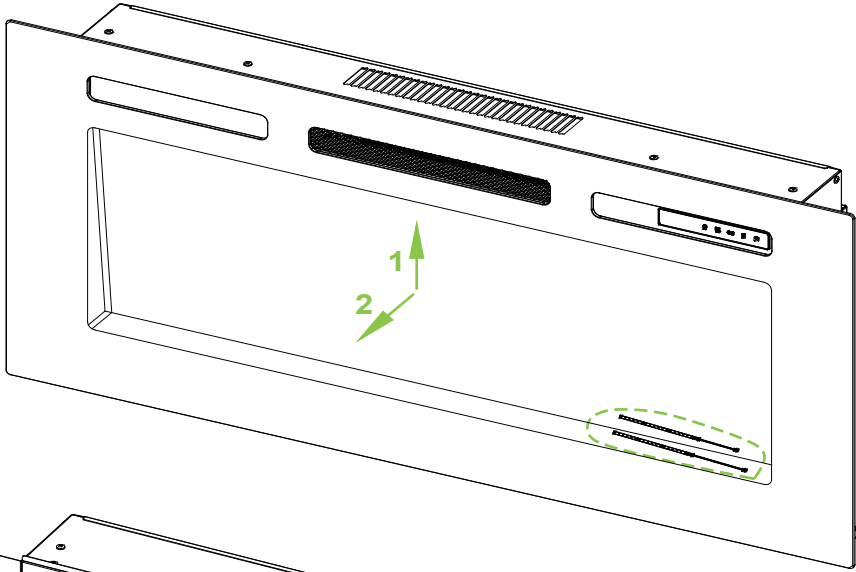

Installing the Appliance

- 3** 3.Plug the fireplace and then push it into the frame.

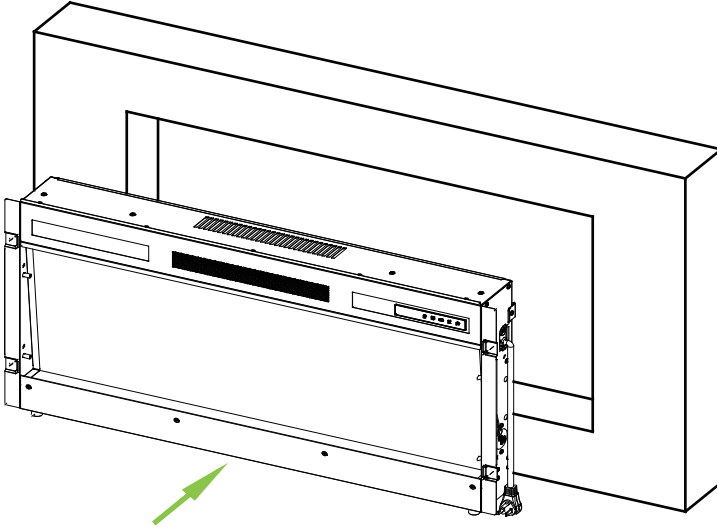

- 4** 4. Secure the fireplace with four ST4x12 screws.

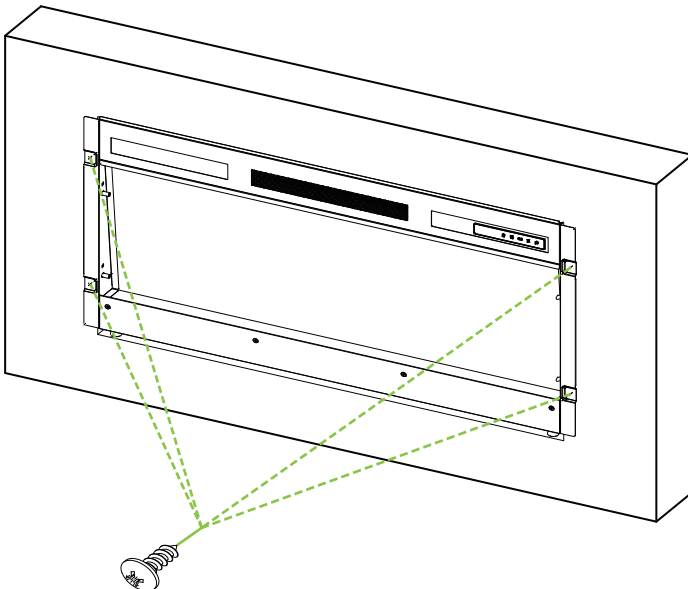

Installing the Appliance

5 5. Decorate the fireplace with crystals.

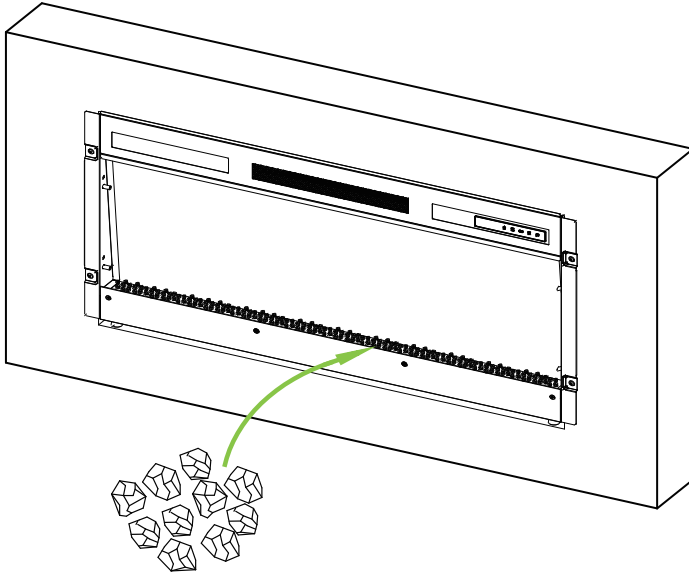

6 6. Connect backlight strips with the compatible connecting wire. Confirm where you want to locate the backlight strips, fix the backlight strip brackets with ST3x12 screws, and then install the backlight strips into the brackets.

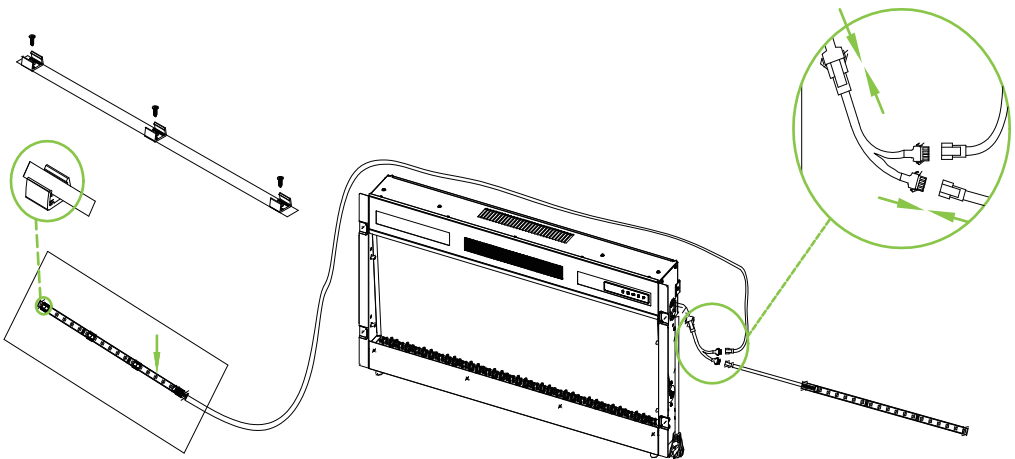

Installing the Appliance

7 7. Install the glass panel back.

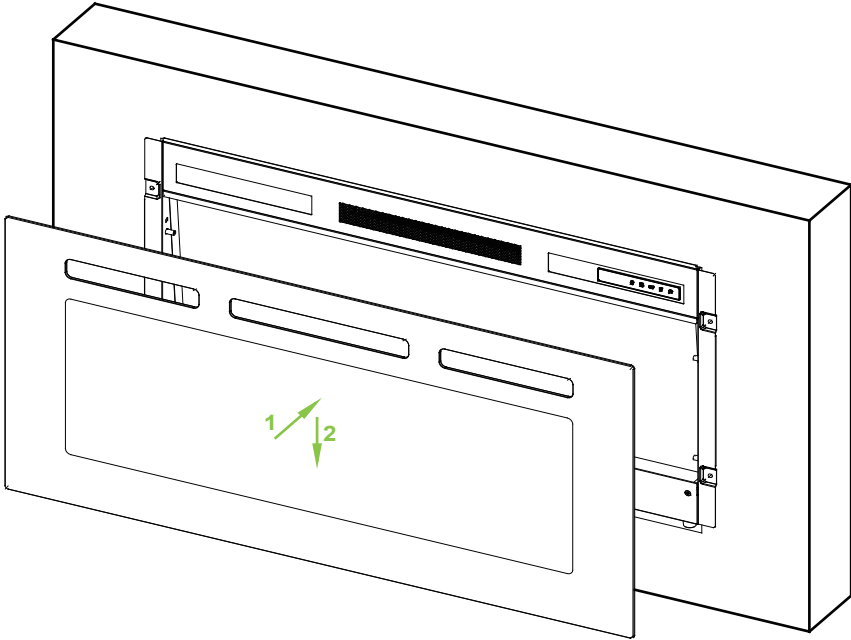

OPERATING INSTRUCTIONS

1. GENERAL

WARNING! Do not operate the appliance if it is damaged or has malfunctioned. If you suspect the appliance is damaged or has malfunctioned, call a qualified service engineer to inspect the appliance, and replace any part of the electrical system if necessary before re-use.

WARNING! To reduce the risk of fire, keep textiles, curtains, or any other flammable material a minimum distance of 1 meter from the air outlet.

- **MAKE SURE** the plug fits tight in the outlet. Faulty wall outlet connections or loose plugs can cause the outlet to overheat.
- **DO NOT** disconnect the power at the mains supply whilst the appliance is running. Use the functions on the remote to turn the fire off and ensure the mains switch has been moved to the off position before disconnecting.



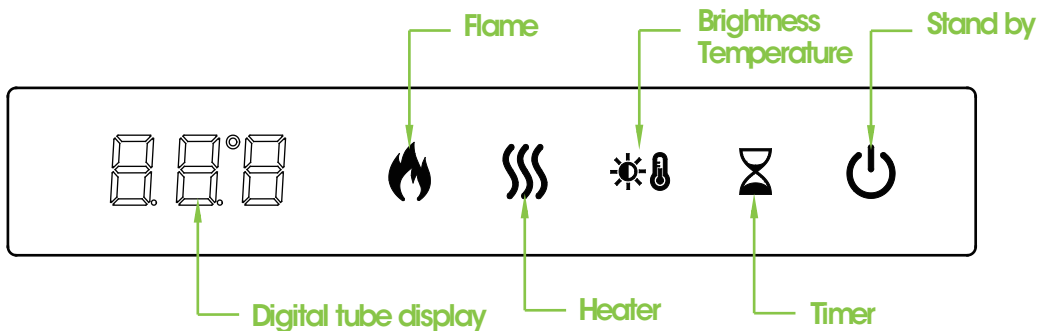



2. Manual Control Panel



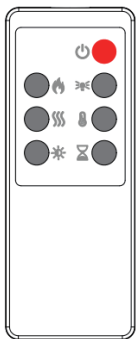

| Name | Function | Product display |
|----------------------------|---|---|
| Stand by | Turn on the Flame and Backlight lights. Turn off all function and remember the flame, backlight and temperature states.The initial status is F.01, B.01 and Fb.5. | When the appliance be turned on, the digital tube displays the FLAME states. |
| Flame | Press once enter the flame setting query state. Press in 10 seconds, cycles through 12 colors and flame lighting off. | Digital tube displays F.01、F.02、 ... F.12、 F.00, |
| Heater | Press once enter the heater setting query state.Press in 10 seconds, cycles through Heat Low/ High /OFF. | Digital tube displays H.Lo, H.HI and H.oF. |
| Brightness/ Temperature | Press Flame button, then press this button in 10 seconds, cycles through 5 brightness settings. Press Heater button, then press this button in 10 seconds, cycles through 16-28 C, 58 C, total 14 settings. (62-82 F, 99 F, total 14 settings.)Press Heater button, then long press this button in 10 seconds, change between C and F.Press backlight button on remote, then press this button in 10 seconds, cycles through 5 brightness settings. | <p>Digital tube displays Fb.5, Fb.4 ... Fb.1</p> <p>Digital tube displays the corresponding temperature.</p> <p>Digital tube displays bb.5, bb.4 ... bb.1</p> |
| Timer | Press once enter the timer setting query state.Press in 10 seconds, cycles through 0H.0.5H, 1H, 2H...9H, total 11 settings.When the timing ends, the product will enter the standby state. | Digital tube displays the corresponding time. |

Standby memory: When turn off the product, the flame, backlight and temperature states can be remembered. Turn on the product again, and the product will display the status before turnoff. This feature does not apply if the plug is pulled out of the socket. Digital tube goes out after 10 seconds of no operation.

3.Remote Handset

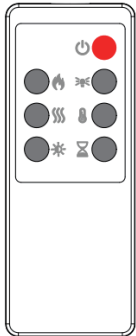
| | Button | Function | Product display |
|---|--|--|--|
|  |  Stand by | Turn on the Flame and Backlight lights. Turn off all function and remember the flame, backlight and temperature states. The initial status is F.01, B.01 and Fb.5. | When the appliance be turned on, the digital tube displays the FLAME states. |
| |  Flame | Cycles through 12 colors and flame lighting off. | Digital tube display F.01、 F.02、 ... F.12、 F.00. |
| |  Backlight | Cycles through 12 colors and backlight lighting off. | Digital tube display b.01 ,b.12, b.00(off). |
| |  Heater | Heat Low/ High /OFF | Digital tube display H.Lo, H.HI and H.oF. |
| |  Temperature | Press once enter the temperature setting query state, press this button in 10 seconds, Cycles through 16-28 C, 58 C, total 14 settings. (62-82 F, 99 F, total 14 settings.) Press Heater button, then long press this button in 10 seconds, change between C and F. | Digital tube displays the corresponding temperature. |

| | Button | Function | Product display |
|--|---|--|---|
|  |  Brightness | <p>Press Flame button, then press this button in 10 seconds, cycles through 5 brightness settings.</p> <p>Press Backlight button, then press this button in seconds. Cycles through 5 brightness settings.</p> | <p>Digital tube display Fb.5, Fb.4 ... Fb.1</p> <p>Digital tube display bb.5, bb.4 ... bb.1</p> |
| |  Timer | <p>Press once enter the timer setting query state, Press in 10 seconds, cycles through 0H.0.5H, 1H, 2H...9H, total 11 settings.</p> <p>When the timing ends, the product will enter the standby state.</p> | <p>Digital tube displays the corresponding time.</p> |

RESETTING THE THERMAL CUT OUT

The appliance is fitted with an Electronic Safety Control (E.S.). This is a safety device which switches off the fire if, for any reason, the appliance overheats, e.g. when covered. If the heater stops operating while the flame effect continues working normally, this indicates that the E.S. Control is in operation. The E.S. control can only be re-set after the appliance has cooled down, and the appliance has been reset. Resetting of the E.S. Control procedures are as follows:

1. Press button **STAND BY** on fire to turn off the appliance and leave it off for approximately 10-15 minutes.
2. Remove any obstruction to the fan heater outlet or fan blades etc. Make sure that the power supply is disconnected with the plug socket outlet while doing this.
3. Turn on the appliance and the E.S. Control will be reset.
4. Ensure that the appliance is functioning correctly. If the E.S. Control operates again, the appliance should be checked by a competent electrician.

GENERAL

WARNING! ALWAYS turn the heater OFF and unplug the power cord from the outlet before cleaning, performing maintenance, or moving this fireplace. Fail to do so could result in electric shock, fire, or personal injury.

WARNING! NEVER immerse in water or spray with water. Doing so could result in electric shock, fire, or personal injury.

METAL:

- Buff using a soft cloth, slightly dampened with a citrus oil-based product.
- DO NOT use brass polish or household cleaners as these products will damage the metal trim.

GLASS:

- Use a good quality glass cleaner and dry thoroughly with a paper towel or lint-free cloth.
- NEVER use abrasive cleansers, liquid sprays, or any cleaner that could scratch the surface.

PLASTIC:

- Wipe gently with a slightly damp cloth and a mild solution of dish soap and warm water.
- NEVER use abrasive cleansers, liquid sprays, or any cleaner that could scratch the surface.

VENTS:

- Use a vacuum or duster to remove dust and dirt from the heater and vent areas.
- Clean the exterior of the fireplace with a slightly damp cloth or duster.

MAINTENANCE

WARNING! Risk of electric shock! DO NOT OPEN! No user-serviceable parts inside!

Electrical and Moving Parts:

- The fan motors are lubricated at the factory and will not require lubrication.
- Electrical components are integrated in the fireplace and are not serviceable by the consumer.

Replacement Parts:

- Use only replacement parts supplied by the manufacturer. Use of any other parts, or modifying the fireplace in any way, will void all warranties.

LIMITED WARRANTY

This warrants to the original purchaser that this product is free from defects in material and workmanship as of the date of purchase and that it will, under normal use and proper care, remain so for one year from the date of purchase. Missing or initially defective parts will be replaced free of charge during the period of this limited warranty. If parts are unavailable, comparable replacement or refund will be given. **The original dated sales receipt is required for all warranty claims.** This warranty does not cover damage which has occurred during transport from the point of purchase to the consumer's home. This warranty does not cover glass, light bulbs, batteries, transportation, labor, or other issues not associated with the manufacture of the product.

This product is for residential use only. Any and all commercial use of this product voids all warranties, and frees the manufacturer from all liability.

Read and understand all assembly and operating instructions, and all safety information and warnings, before use. The following will void this warranty: Damage caused from tampering with, modifying, or altering the fireplace insert in any manner; Damage due to incorrect assembly, improper care, misuse, or abuse; Damage from being used with the wrong power source; Water damage; Damage caused from this insert being used outdoors; Damage caused from this insert being used for excessive periods of time; Damage caused by the insert being used in a commercial application; Damage from use as a primary heat source; Other misuse or abuse not specifically listed herein.

This product is not intended to be used as a primary heat source. It is for supplemental heating purposes only.

| TROUBLESHOOTING

Disconnect the appliance completely and let it cool prior to any service. Only a qualified service personnel should service and repair this electric appliance.

| Problem | Possible Cause | Solution |
|---|--|--|
| Fireplace turns off and will not turn on. | Fireplace has overheated and safety device has caused thermal switch to disconnect or home circuit breaker has opened. | Reset switch by turning main power off and waiting to turn it back on or breaker circuit breaker. |
| Flame is not moving. | 1. Loose wiring. 2. Flame motor defective | 1. Inspect wiring for loose connections. 2.Call a qualified service technician to replace the flame motor. |
| Remote control does not work. | 1.Low batteries. 2.Not aiming control correctly. 3.Defective remote control and/or sensor. | 1.Replace the batteries of the remote control. 2.Aim control at the sensor behind the control panel. 3.Replace the remote control and/or sensor. |

TROUBLESHOOTING

| Symptom | Solution |
|----------------------|--|
| No operation/no fan | Check fuse by replacement, Check for safety cut-off operation |
| No fire effect light | Check the LED light with technician. |

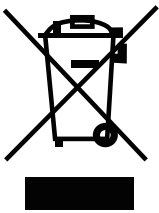

Meaning of crossed –out wheeled dustbin:

- Do not dispose of electrical appliances as unsorted municipal waste, use separate collection facilities.
- Contact you local government for information regarding the collection systems available.
- If electrical appliances are disposed of in landfills or dumps, hazardous substances can leak into the groundwater and get into the food chain, damaging your health and well-being.

HELP CENTER

Question about your product? We're here to help. Visit us at:

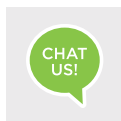

Chat Support

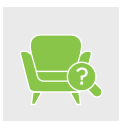

Product Inquiry

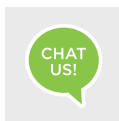

Orders FAQ



Product Assembly



Returns & Refunds

We Stand Behind the Quality of Their Furniture

If you have any issues with your item please let us know! We will always do our best to come up with a solution that you will be happy with.

Please get in touch with our customer service team before returning the product.

And pls do not throw the original box(es) if you have not finished assembling or confirmed no quality issues.

Length of return period:

Items can be returned within 30 days of purchase.

In the meanwhile, everything you purchased from us comes with a one-year warranty.

Who is responsible for the return shipping fee:

We will cover the return shipping fees if:

1. Your item has a manufacturing defect in its materials or workmanship. For example, torn wicker or misaligned screw holes. We will send you a prepaid shipping label after photos are sent.
2. Your item has been damaged in transit. For example, glass is broken or wicker is damaged. We will send you a prepaid shipping label after photos are sent.
3. You receive the wrong box(es) due to a warehouse error. We will send you a prepaid shipping label after photos are sent of the wrong SKU numbers on the outer box(es).
4. One or more boxes are lost in transit. We will send you a prepaid shipping label if you no longer want the item.

*However, we still hope to work with you for a better solution instead of a return. Please don't hesitate to contact our customer service team.

Customer will cover the return shipping fees if:

1. You don't like the product(s) after receiving the box(es).
2. You no longer need the product(s) but you have received the box(es).
3. You buy the product(s) by mistake but you have received the box(es).
4. Order/Shipment cancellation failed and you have received the box(es).

Return Request

In order to get a full refund as described in this return policy, all items must be: (1) In a brand new/unused condition, please provide photos before and after packaging. (2) When returning, all accessories and parts are firmly packed in all original packaging.

If your return does not meet the requirements, you may not get a full refund.

When will I be refunded?

The refund is released once the goods have been returned to our warehouse.

What if the product is damaged/defective outside of the valid return period?

We want you to be a happy customer. Please reach out to us by email and we will come up with a solution to make sure you are satisfied.