

Assembly Instruction Sheet

Tools Required: Flathead screwdriver, Phillips screwdriver, pliers, wire cutters, wire strippers, electrical tape, safety glasses.

Bulb Recommended: (1) Medium Base 100W Maximum

Estimated Assembly Time: 20-30 minutes

Preparation: Identify and inspect all parts before beginning installation. Check package content list and diagrams below to be sure all parts are present. If any parts are missing or damaged, do not attempt to assemble, install, or operate the fixture. Contact customer service for replacement parts.



Warnings and Cautions

Turn off electricity at circuit breaker or main fuse box before installation. Consult a licensed electrician if in doubt.

These instructions are provided for your safety. It is very important you read them completely before installing the fixture. We strongly recommend that a licensed, professional electrician perform the installation.

Disconnect fixture from power source before replacing bulbs. Make sure bulbs are given sufficient time to cool before removal. Do not subject glass parts to any shock while in operation or shattering may result.

Package Contents

Part	Description	Quantity
A	Mounting Screw	3 pcs.
B	Fixture Body	1 pc.
C	Shade	1 pc.

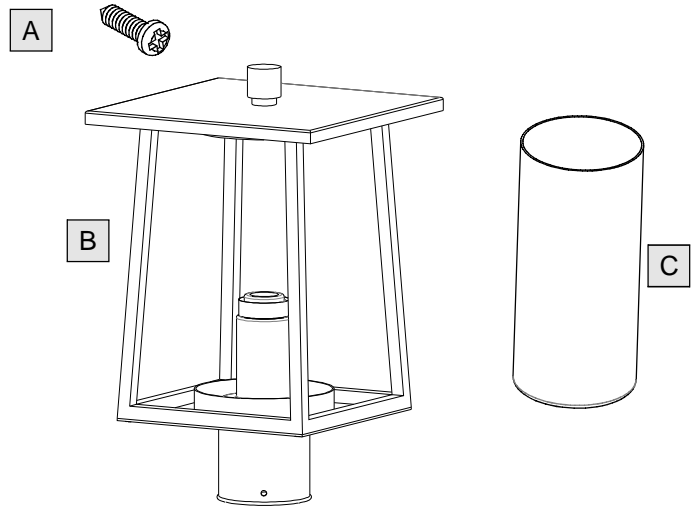

FINISH: MYSTIC BLACK

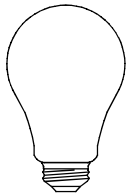
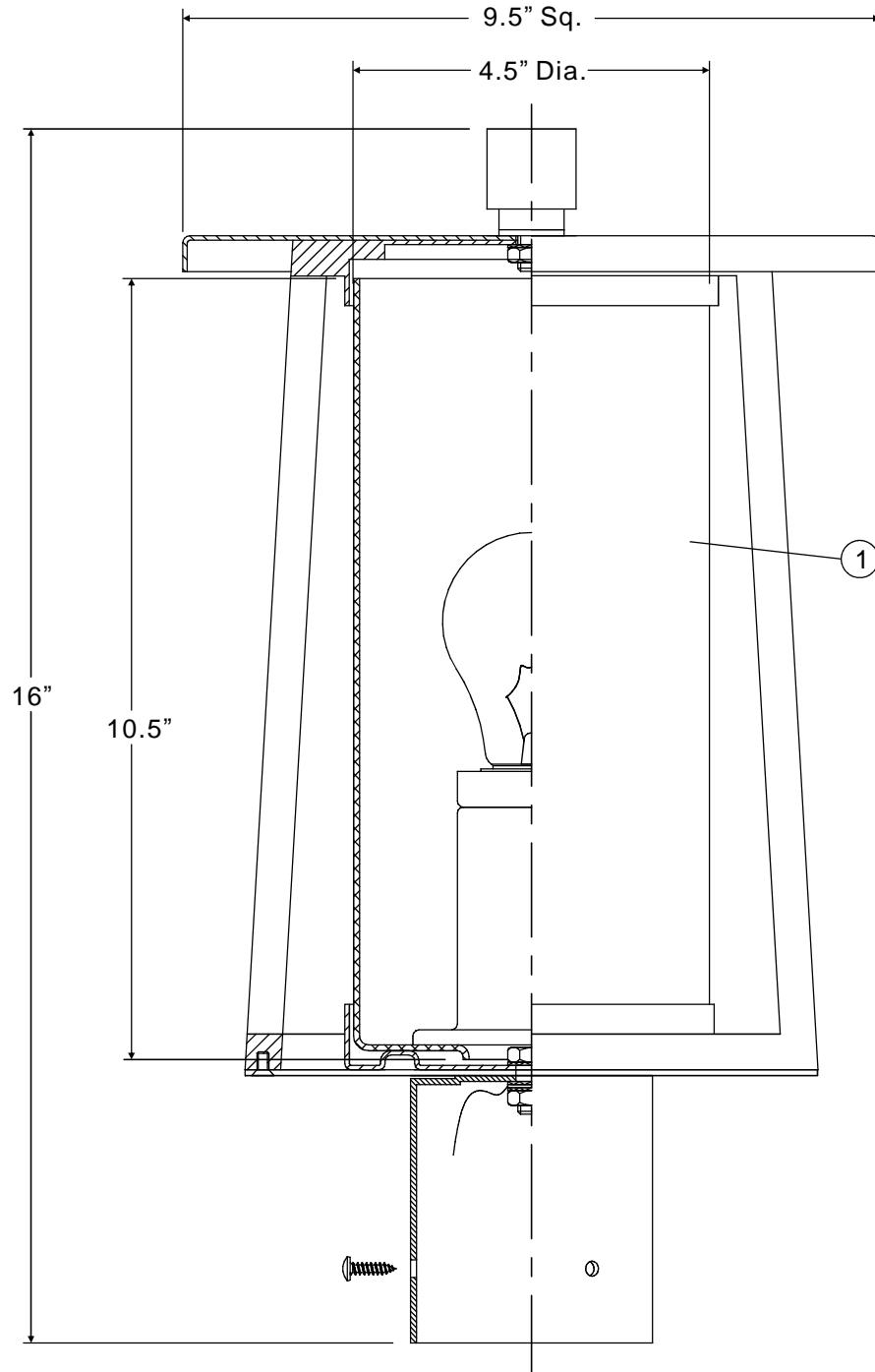
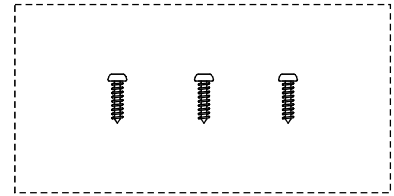

(1)100W Medium Base Bulb
(Not Supplied)

NOTE: ALL DIMENSIONS ARE ROUNDED UP TO THE NEAREST 1/2"

NO.	PART NUMBER	REPLACEMENT PART DESCRIPTION	REQ.
1		GLASS CLEAR HAMMERED	1

Assembly Instruction Sheet

STEP 1 - Remove the Cage

- A. Remove the Cage from the Fixture Body (B) by unscrewing the Lock Screws on the bottom of the fixture.

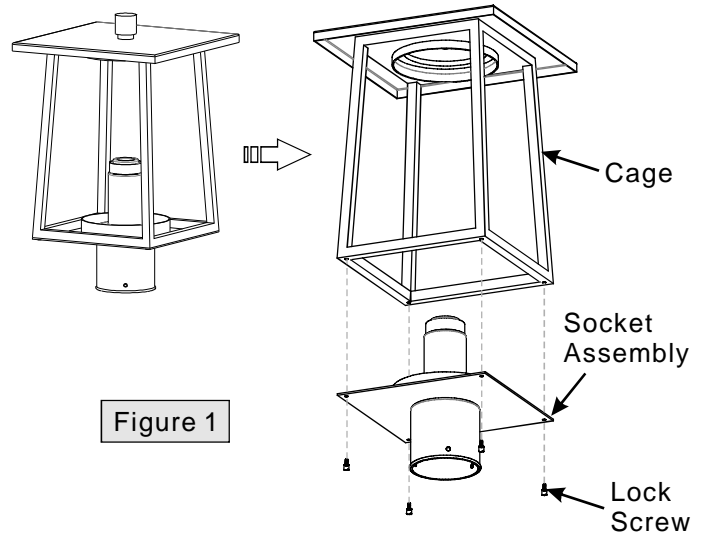

STEP 2 - Install Shade

- A. Remove the Socket Spacer and the Socket Collar from the Socket.
B. Place Shade (C) over the Socket and secure with the Socket Spacer. Hand tighten until snug.
C. Thread the Socket Collar onto the Socket and hand tighten until snug.

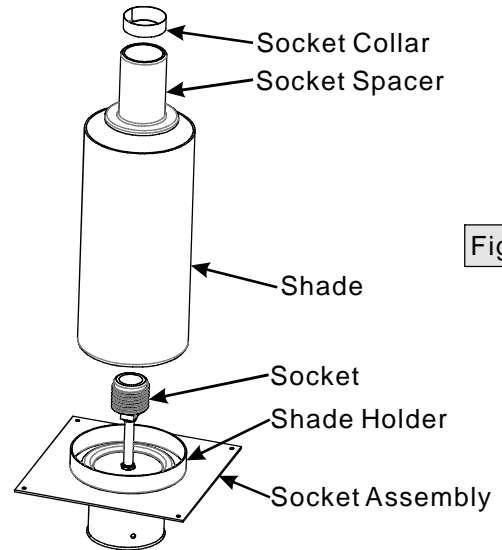

STEP 3 - Install Bulb

- A. This fixture uses standard bulb with a medium screw base. Maximum 100 watts.
B. Insert bulb and screw snugly into place.

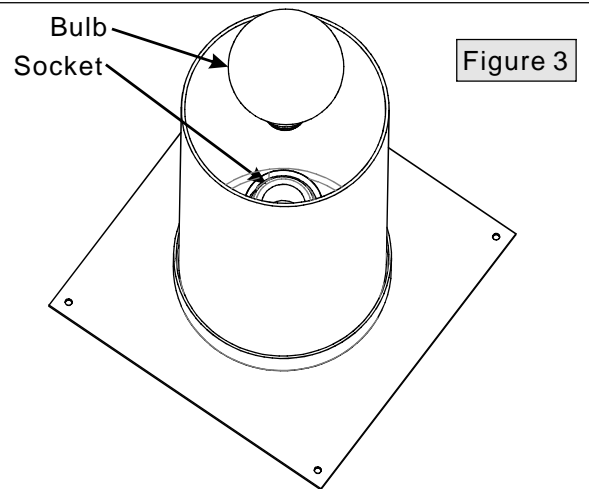

Assembly Instruction Sheet

STEP 4 - Install Cage

- A. Place the Cage back onto the Socket Assembly and secure with the Lock Screws. Hand tighten until snug.

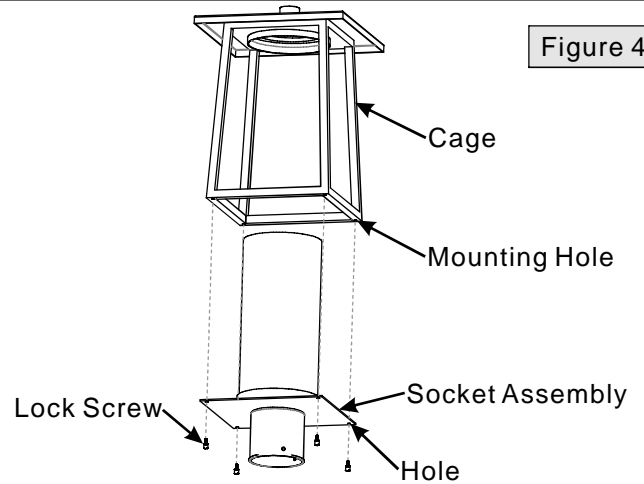

STEP 5 - Drill Pilot Holes on Post

- A. Carefully fit the Post Fitter over the end of the Post (not supplied), making sure the Post Fitter is fully seated.
- B. Mark the drill point for the (3) Mounting Screws, using (3) Mounting Holes as reference. After marking hole locations, remove fixture from post and drill 1/16" pilot holes for screws.

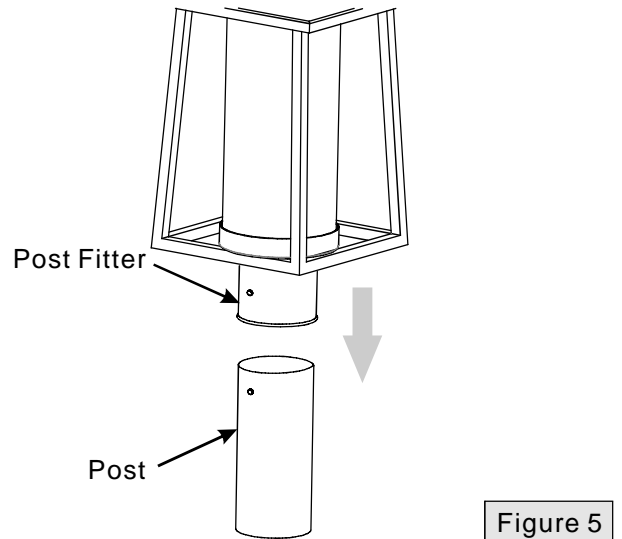

Assembly Instruction Sheet

STEP 6 - Make Wire Connections

- Use standard wire connectors to make all wire connections. (Connectors are not included with fixture.) Strip and prepare wire ends according to instructions supplied with connectors.
- Connect White Supply Wire from the Post to White Wire from fixture.
- Connect Black (or Red) Supply Wire from the Post to Black Wire from fixture.
- Connect Ground Wire from the Post to Ground Wire from fixture.
- Twist connectors until wires are tightly joined together.
- Wrap each connection with approved electrical tape and carefully stuff all the connected wires into the Post.

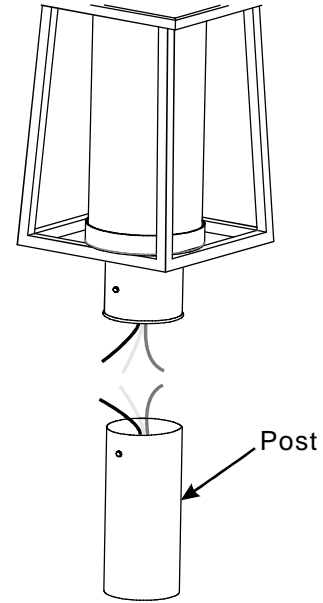

Figure 6

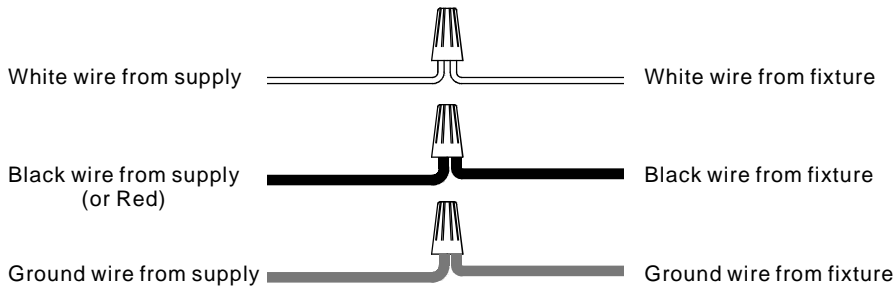

Figure 7

STEP 7 - Attach Fixture Body to Post

- Coat the top 1" of the Post with Clear Silicone Caulk (not supplied) and position the Post Fitter onto the Post. Be sure to seat it completely, aligning the holes in the Fitter with the 1/16" Pilot Holes drilled into the Post.
- Secure the Fixture to Post with (3) Mounting Screws.

Your fixture is now assembled and ready to use.
Enjoy!

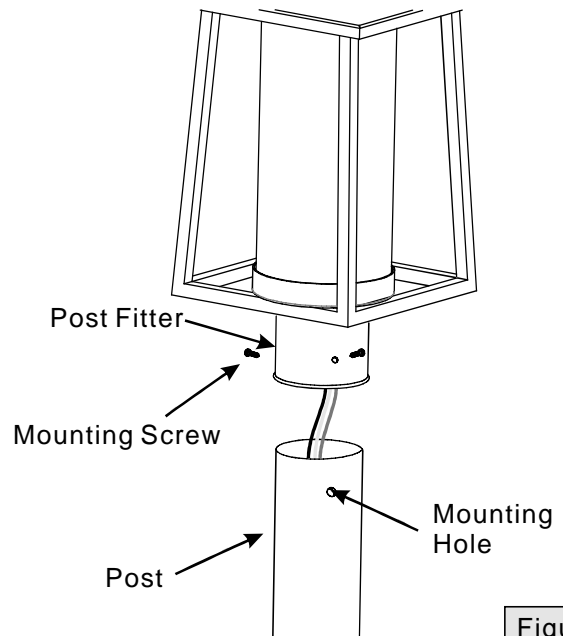

Figure 8