

# Installation & Assembly

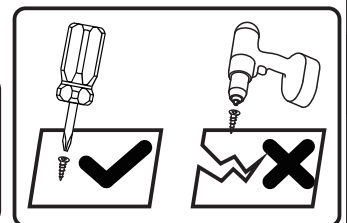
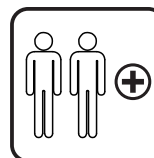
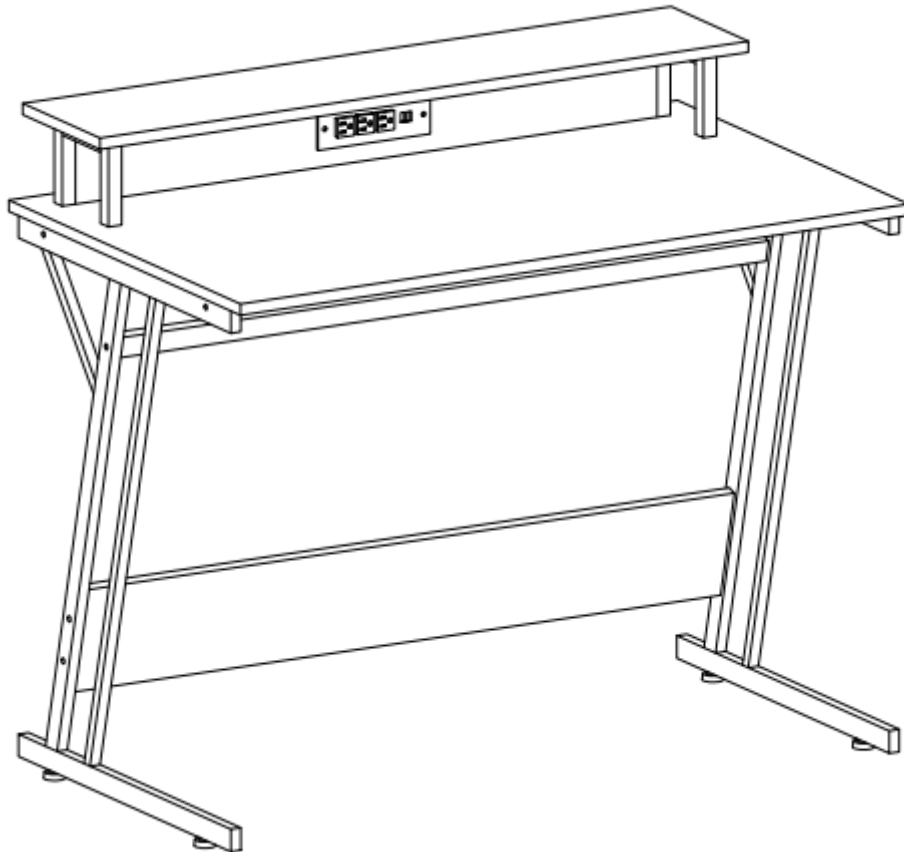

Tools Recommended

**EN\_IMPORTANT, RETAIN FOR FUTURE REFERENCE: READ CAREFULLY.**

**FR\_IMPORTANT: A LIRE ATTENTIVEMENT ET À CONSERVER POUR CONSULTATION ULTÉRIEURE.**









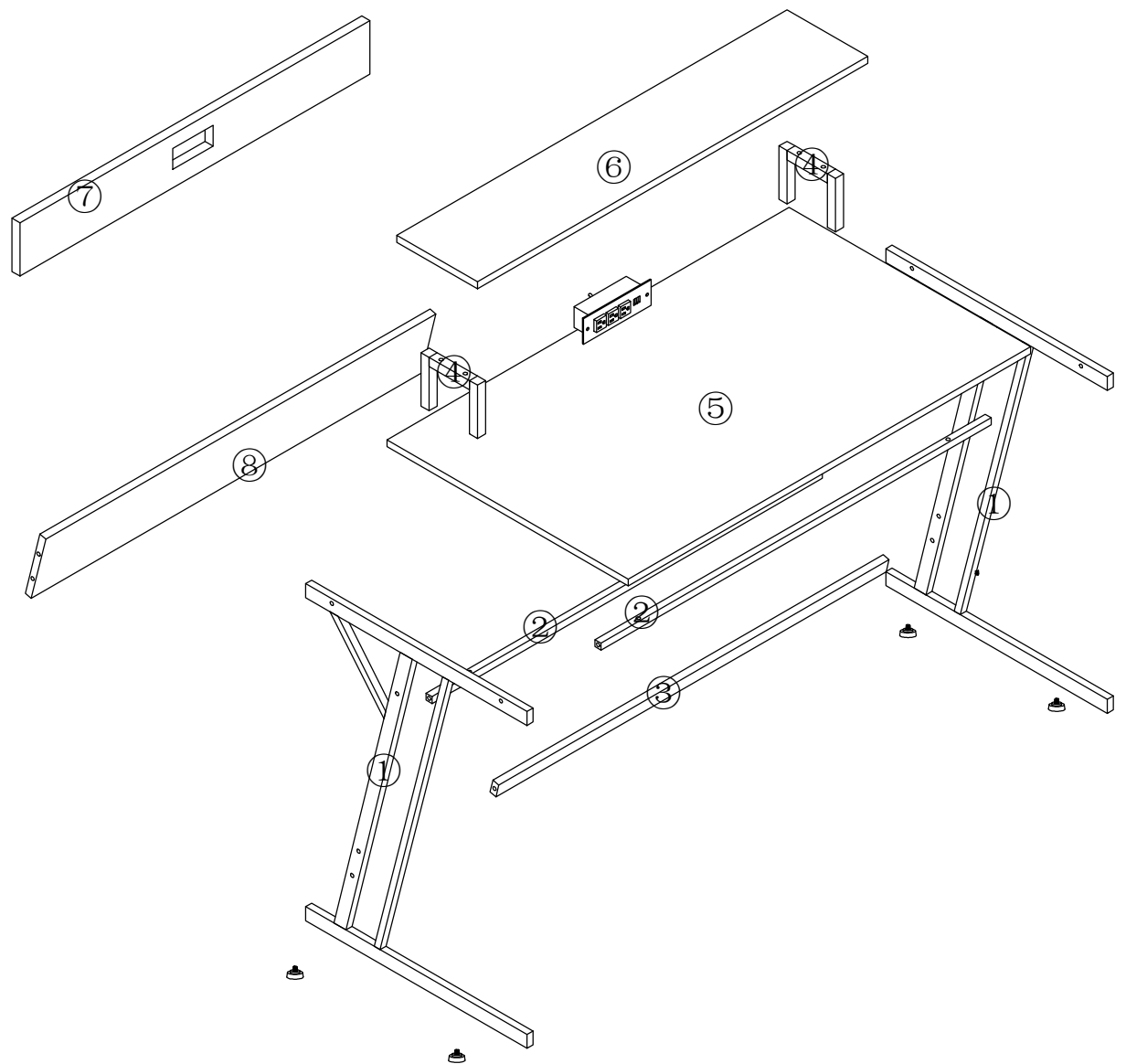

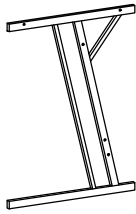
**ES\_IMPORTANTE, LEA Y GUARDE PARA FUTURAS REFERENCIAS.**

**PT\_IMPORTANTE, RETER PARA REFERÊNCIA FUTURA: LEIA ATENTAMENTE.**

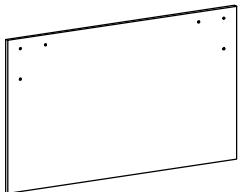
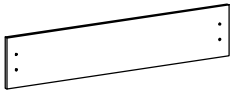
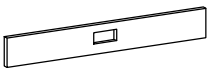
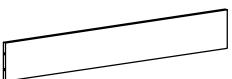
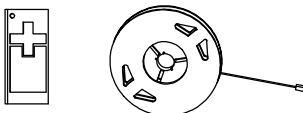
**DE\_WICHTIG! SORGFÄLTIG LESEN UND FÜR SPÄTER NACHSCHLAGEN AUFBEWAHREN.**

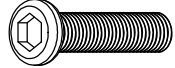
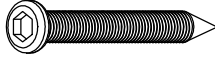
**IT\_IMPORTANTE! CONSERVARE IL PRESENTE MANUALE PER FUTURO RIFERIMENTO E LEGGERLO ATTENTAMENTE.**

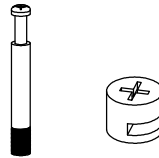
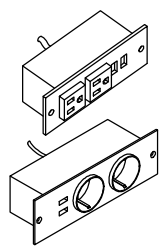

 <p>① × 2</p>	 <p>② × 2</p>	 <p>③ × 1</p>	 <p>④ × 2</p>
 <p>⑤ × 1</p>	 <p>⑥ × 1</p>	 <p>⑦ × 1</p>	 <p>⑧ × 1</p>
 <p>⑨ × 1</p> <p>LED Light Strip</p>			
 <p>A × 6 M6*30</p>	 <p>B × 12 M6*25 +1 (spare)</p>	 <p>C × 6 M5*40</p>	 <p>D × 2 M3.5*14</p>
 <p>E × 4 M6</p>	 <p>F × 2 M6*38</p>	 <p>G × 1</p> <p>UK CA CE</p>	 <p>H × 1</p>

EN\_Do not confuse similar screws.  
 FR\_Ne pas confondre des vis similaires.  
 ES\_No confunda tornillos similares.  
 PT\_Não confundir parafusos semelhantes.  
 DE\_Verwechseln Sie ähnliche Schrauben nicht.  
 IT\_Non confondere le viti simili.

NOTE

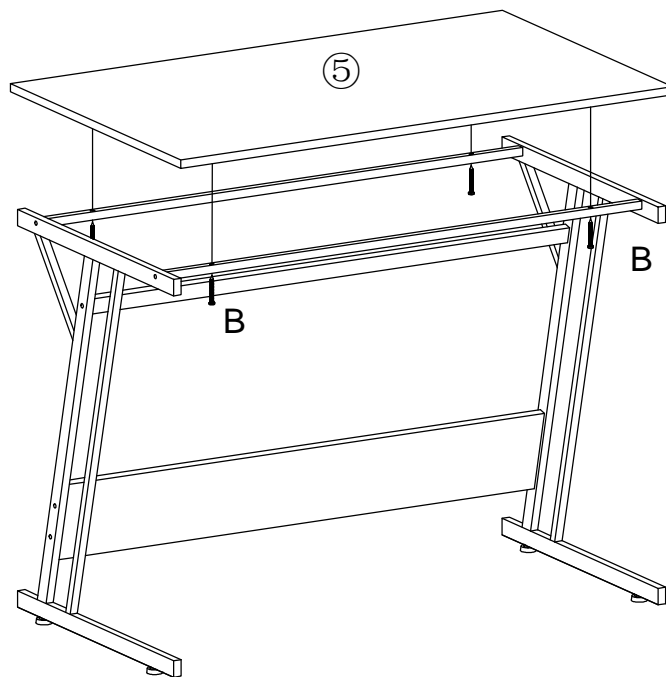
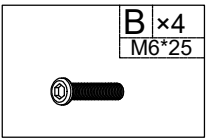
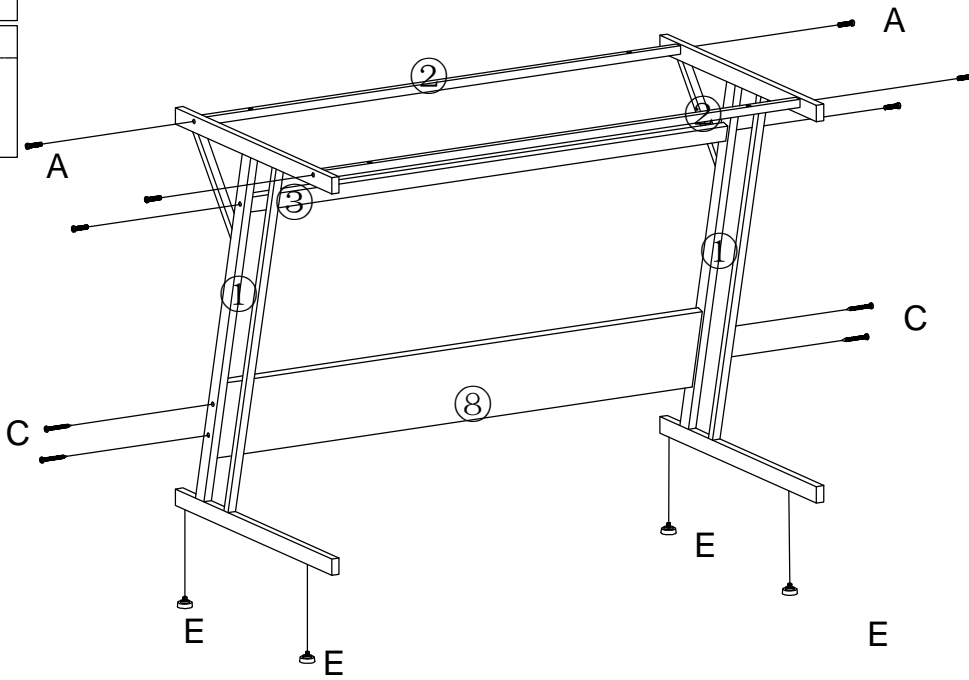
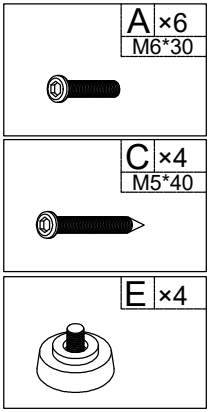

B x4  
M6\*25



C x2  
M5\*40

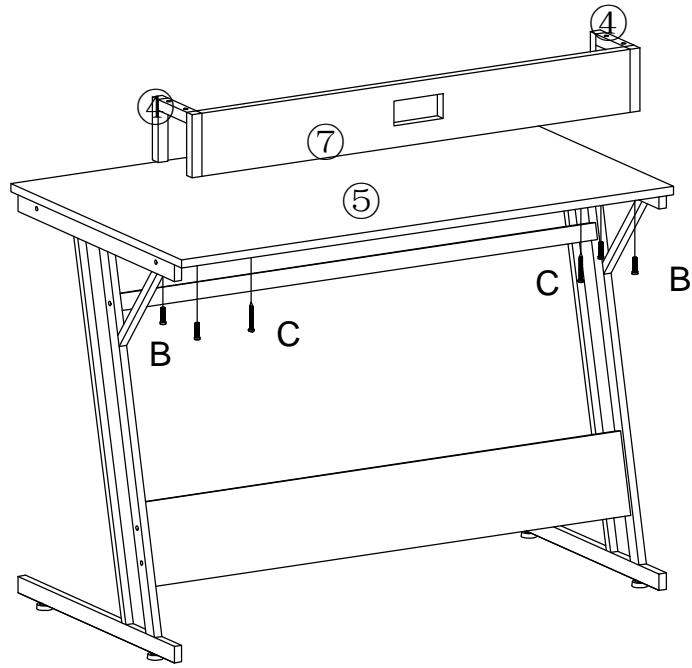

F x2  
M6\*38



B x4  
M6\*25

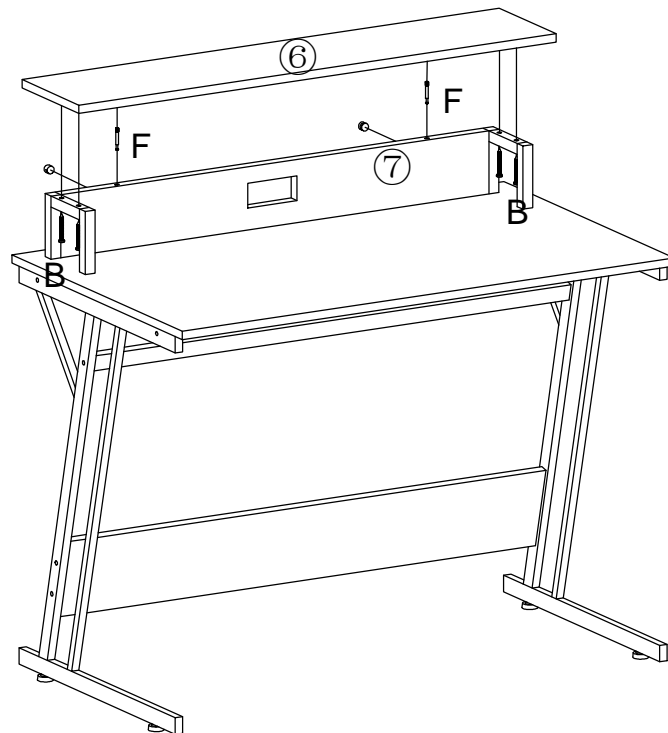

D × 2  
M3.5 × 14

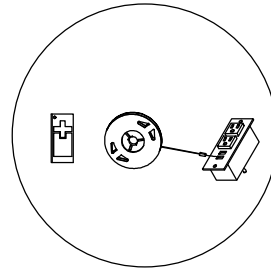
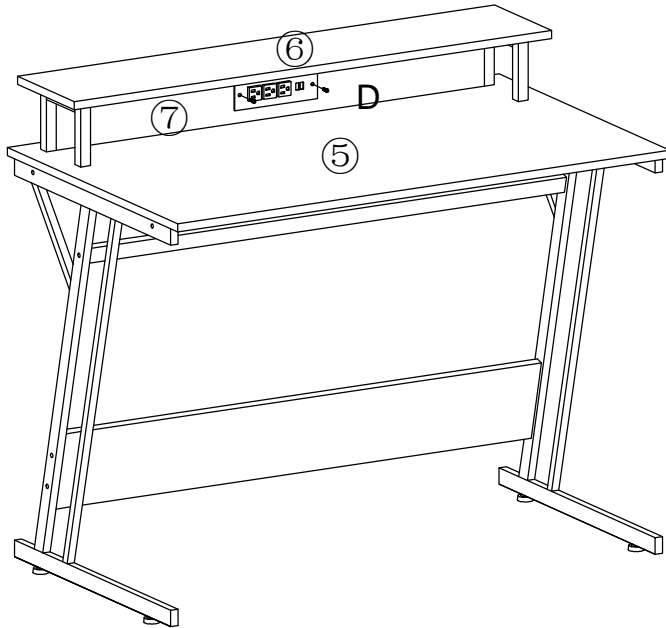

EN\_LED Light Strip can be Post it under

Part 6 follow your needs.

FR\_Les bandes lumineuses à LED peuvent être affichées sous la partie 6 en fonction de vos besoins.

ES\_Tira de luz LED puede ser Publicar bajo la Parte 6 seguir sus necesidades.

PT\_A faixa de luz LED pode ser colocada

na Parte 6 de acordo com as suas necessidades.

DE\_LED Light Strip kann es unter Teil 6

folgen Sie Ihren Bedürfnissen.

IT\_La striscia luminosa a LED può essere

postata sotto la parte 6 per seguire le vostre esigenze.

