



WARNING!

Important information, please read carefully and retain this information for future reference. Only adults are allowed to assemble, keep children away.

English WARNING!

If furniture is tipped over, it may cause serious injury or even death. To prevent tip-over of this furniture, be sure to use it with the wall attachment devices provided. Use the appropriate screws and plugs for your wall.

If the supplied wall attachment devices do not match the walls in your home, consult your local professional to use screws and plugs that fit your walls. Please read and follow each step in the instructions carefully.

Please pay attention to the iron corner protectors and cabinet parts inside the package. If the iron corner guard is damaged, you can just discard it; if you find any broken or damaged cabinet parts, please contact customer service immediately for replacement parts. Sharp edges of metal parts can cause serious injury.

Please pay attention to the glass parts of the cabinet (if included). If you find any broken or damaged parts, contact customer service immediately for replacement. Sharp edges of the glass may cause serious injury.

Deutsch WARNUNG!

Ein Umkippen der Möbel kann zu schweren Verletzungen oder sogar zum Tod führen. Um ein Umkippen dieses Möbels zu verhindern, verwenden Sie es mit den mitgelieferten Wandbefestigungsvorrichtungen. Verwenden Sie die für Ihre Wand geeigneten Schrauben und Dübel.

Wenn die mitgelieferten Wandbefestigungsvorrichtungen nicht zu den Wänden in Ihrer Wohnung passen, wenden Sie sich an einen Fachmann, um Schrauben und Dübel zu verwenden, die zu Ihren Wänden passen. Bitte lesen und befolgen Sie jeden Schritt in der Anleitung sorgfältig.

Achten Sie bitte auf den Eiseneckenschutz und die Schrankteile in der Verpackung. Wenn der eiserne Eckschutz beschädigt ist, können Sie ihn einfach wegwerfen; wenn Sie gebrochene oder beschädigte Schrankteile finden, wenden Sie sich bitte umgehend an den Kundendienst, um Ersatz zu erhalten. Scharfe Kanten von Metallteilen können schwere Verletzungen verursachen.

Achten Sie bitte auf die Glasteile der Vitrine (falls vorhanden). Wenn Sie zerbrochene oder beschädigte Teile finden, wenden Sie sich bitte umgehend an den Kundendienst, um Ersatz zu erhalten. Scharfe Kanten des Glases können zu schweren Verletzungen führen.

Français AVERTISSEMENT !

Le basculement du meuble peut entraîner des blessures graves, voire mortelles. Pour éviter que ce meuble ne bascule, veuillez à l'utiliser avec les dispositifs de fixation murale fournis. Utilisez les vis et les chevilles appropriées à votre mur.

Si les dispositifs de fixation murale fournis ne correspondent pas aux murs de votre maison, consultez votre professionnel local pour utiliser des vis et des chevilles adaptées à vos murs. Veuillez lire et suivre attentivement chaque étape des instructions.

Veillez faire attention aux protections d'angle en fer et aux pièces de l'armoire à l'intérieur de l'emballage. Si le protège-coin en fer est endommagé, vous pouvez simplement le jeter ; si vous trouvez des pièces de l'armoire cassées ou endommagées, veuillez contacter immédiatement le service clientèle pour les remplacer. Les bords tranchants des pièces métalliques peuvent provoquer des blessures graves.

Faites attention aux parties en verre de l'armoire (si elles sont incluses). Si vous trouvez des pièces cassées ou endommagées, contactez immédiatement le service clientèle pour les remplacer. Les bords tranchants du verre peuvent provoquer des blessures graves.

Italiano

AVVERTENZA!

Il ribaltamento del mobile può causare gravi lesioni o addirittura la morte. Per evitare il ribaltamento di questo mobile, assicurarsi di utilizzarlo con i dispositivi di fissaggio a parete in dotazione. Utilizzare le viti e i tasselli adatti alla parete.

Se i dispositivi di fissaggio a parete forniti non corrispondono alle pareti della vostra casa, consultate il vostro professionista di fiducia per utilizzare viti e tasselli adatti alle vostre pareti. Leggere e seguire attentamente ogni fase delle istruzioni.

Prestare attenzione alle protezioni angolari in ferro e alle parti del mobile contenute nella confezione. Se la protezione angolare in ferro è danneggiata, è possibile scartarla; se si trovano parti del mobile rotte o danneggiate, contattare immediatamente il servizio clienti per la sostituzione. I bordi affilati delle parti metalliche possono causare gravi lesioni.

Prestare attenzione alle parti in vetro del mobile (se incluse). Se si riscontrano parti rotte o danneggiate, contattare immediatamente il servizio clienti per la sostituzione. I bordi affilati del vetro possono causare gravi lesioni.

Español

ADVERTENCIA

Si el mueble vuelca, puede causar lesiones graves o incluso la muerte. Para evitar que este mueble vuelque, asegúrese de utilizarlo con los dispositivos de fijación a la pared suministrados. Utilice los tornillos y tacos adecuados para su pared.

Si los dispositivos de fijación a la pared suministrados no se ajustan a las paredes de su hogar, consulte a su profesional local para utilizar tornillos y tacos que se ajusten a sus paredes. Lea y siga atentamente cada paso de las instrucciones.

Preste atención a las cantoneras de hierro y a las piezas del mueble que se encuentran dentro del paquete. Si la cantonera de hierro está dañada, puede desecharla; si encuentra alguna pieza del armario rota o dañada, póngase en contacto inmediatamente con el servicio de atención al cliente para que se la cambien. Los bordes afilados de las piezas metálicas pueden causar lesiones graves.

Preste atención a las piezas de cristal del armario (si están incluidas). Si encuentra alguna pieza rota o dañada, póngase en contacto inmediatamente con el servicio de atención al cliente para su sustitución. Los bordes afilados del cristal pueden causar lesiones graves.

한국어

경고!

가구가 넘어지면 심각한 부상이나 사망에 이를 수 있습니다. 가구가 넘어지는 것을 방지하려면 반드시 제공된 벽 부착 장치와 함께 사용하세요. 벽에 적합한 나사와 플러그를 사용하세요.

제공된 벽 부착 장치가 집의 벽과 일치하지 않는 경우 현지 전문가에게 문의하여 벽에 맞는 나사와 플러그를 사용하세요. 지침의 각 단계를 주의 깊게 읽고 따라주세요.

패키지 내부의 철제 모서리 보호대와 캐비닛 부품에 주의를 기울이세요. 철제 모서리 보호대가 손상된 경우 그냥 버리고, 캐비닛 부품이 파손되거나 손상된 경우 즉시 고객 서비스에 연락하여 교체해 주세요. 금속 부품의 날카로운 모서리는 심각한 부상을 초래할 수 있습니다.

캐비닛의 유리 부분(포함된 경우)에 주의를 기울이세요. 파손되거나 손상된 부품을 발견하면 즉시 고객 서비스에 연락하여 교체하세요. 유리의 날카로운 모서리는 심각한 부상을 초래할 수 있습니다.

日本語

警告

家具が転倒した場合、重傷を負ったり死亡する恐れがあります。この家具の転倒を防ぐため、必ず付属の壁面取り付け器具を使用してください。壁に適したネジとプラグを使用してください。

付属の壁取付金具がご自宅の壁に合わない場合は、お近くの専門業者にご相談の上、壁に合ったネジとプラグをご使用ください。説明書の各ステップをよく読み、それに従ってください。

パッケージ内のアイアンコーナープロテクターとキャビネット部品にご注意ください。アイアンコーナープロテクターが破損している場合は、そのまま捨てていただいて結構です。キャビネット部品に破損や損傷がある場合は、直ちにカスタマーサービスにご連絡の上、交換してください。金属部品の鋭利な角は、重大な怪我を引き起こす可能性があります。

キャビネットのガラス部品（付属している場合）にもご注意ください。破損または損傷した部品を発見した場合は、直ちにカスタマーサービスにご連絡の上、交換してください。ガラスの角が鋭利な場合、重傷を負う可能性があります。

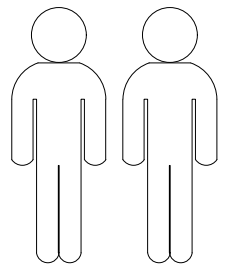
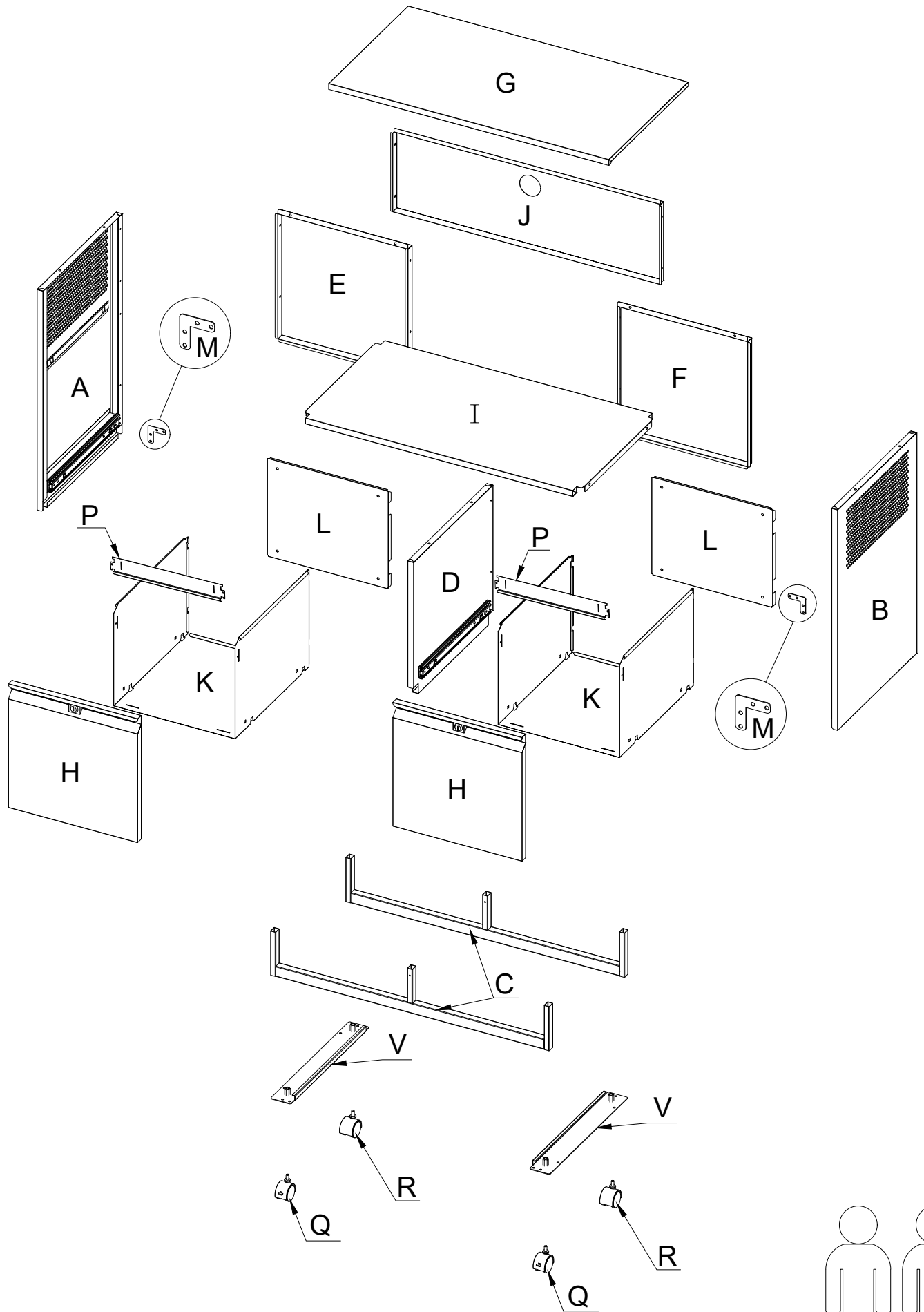

A×1

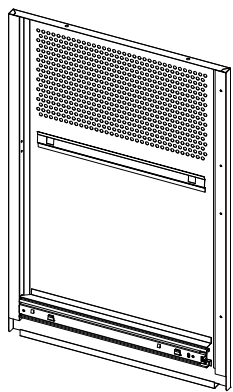

B×1

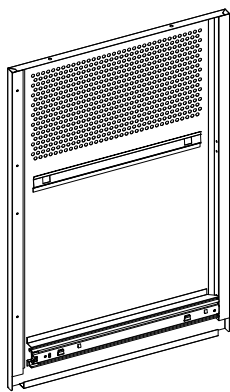

C×2

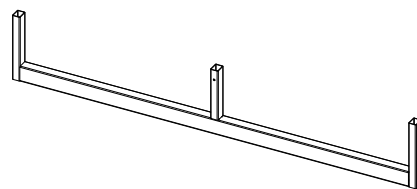

D×1

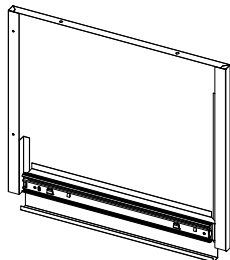

E×1

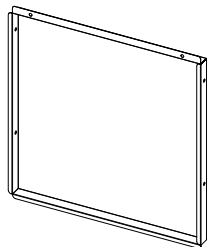

F×1

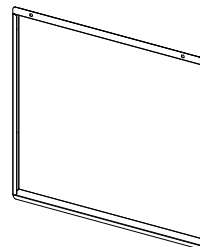

G×1

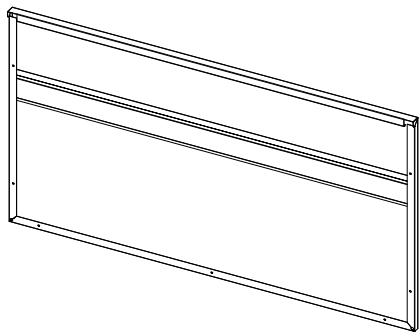

H×2

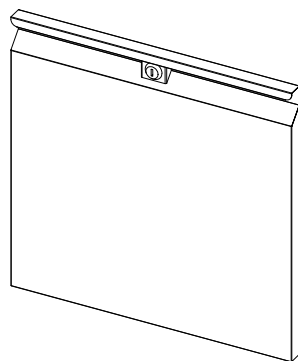

I×1

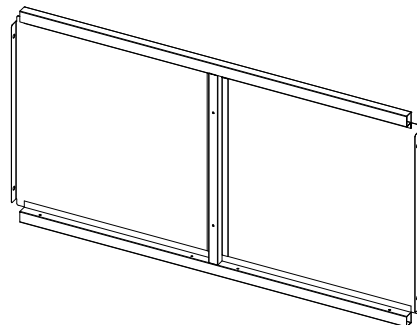

J×1

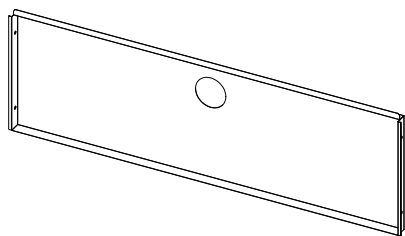

K×2

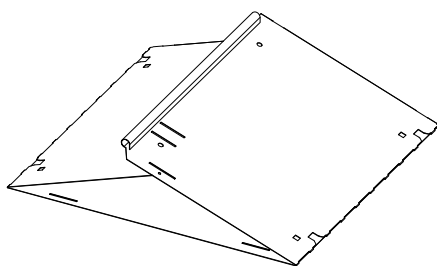

L×2

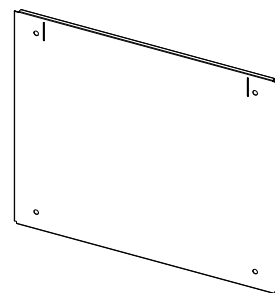

M×2



P×2



Q×2

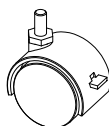

R×2

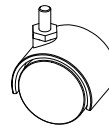

U×48



V×2

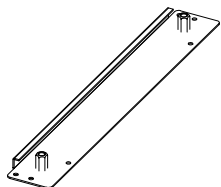

Z×8



1 Insert two Parts C into the channels of the side panels A and B.

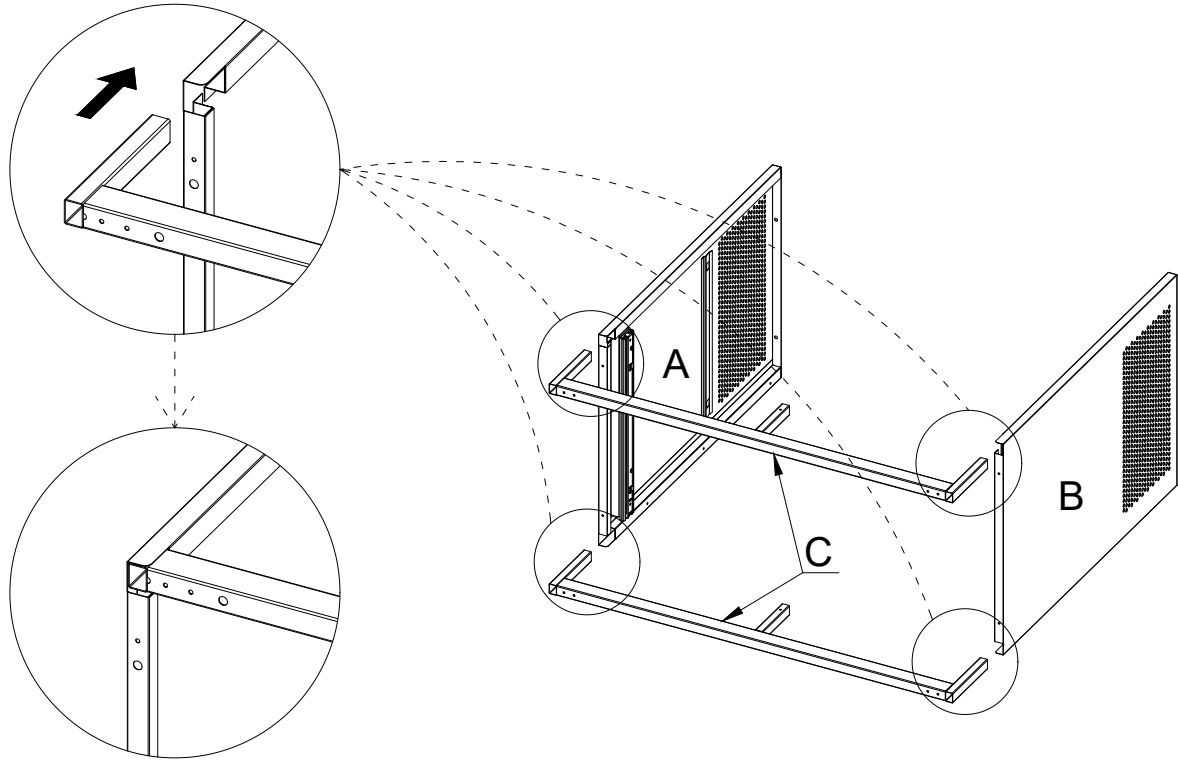

2 Place the two bracket strips V to the bottom and put in twelve screws to keep them in place.

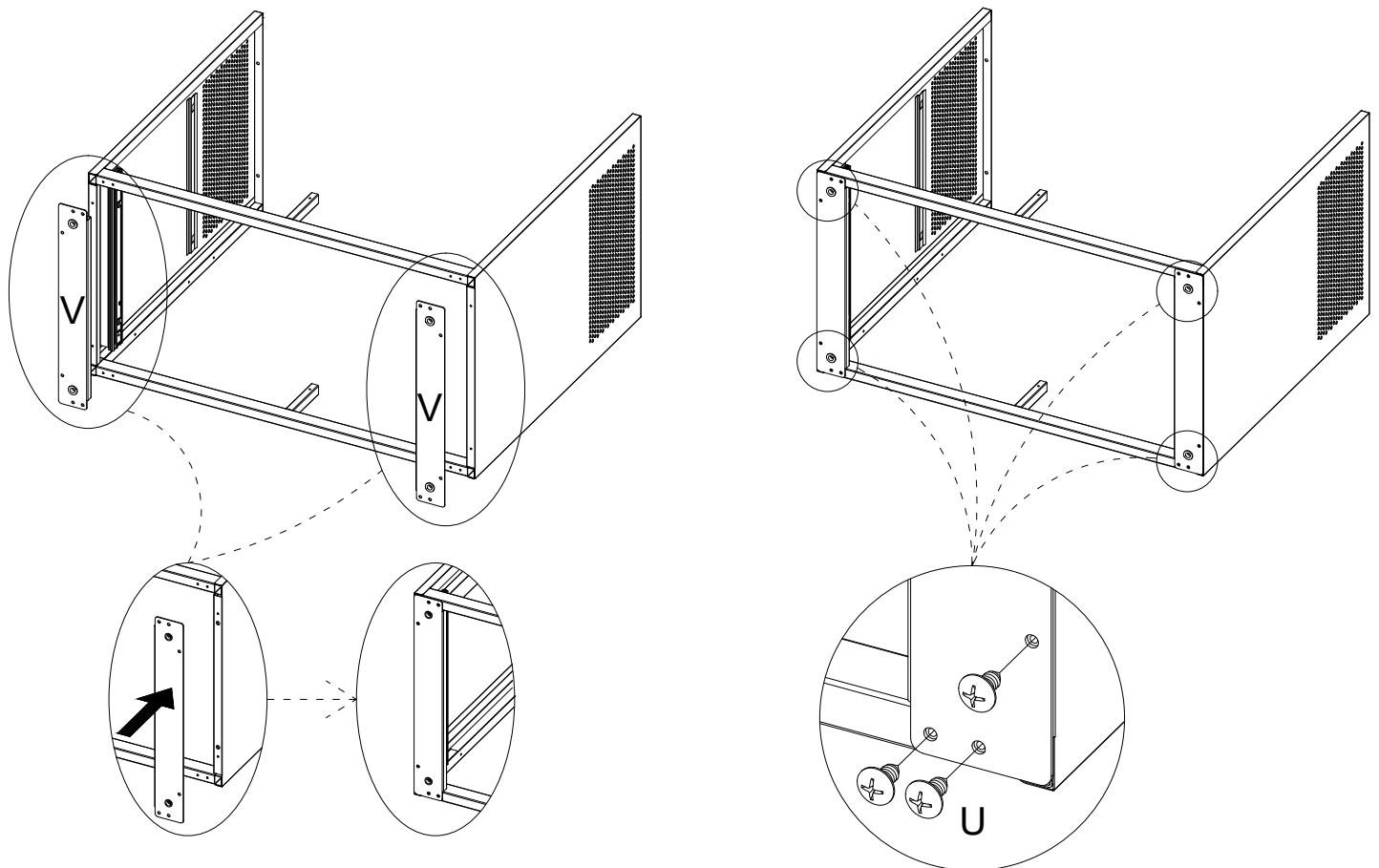

3

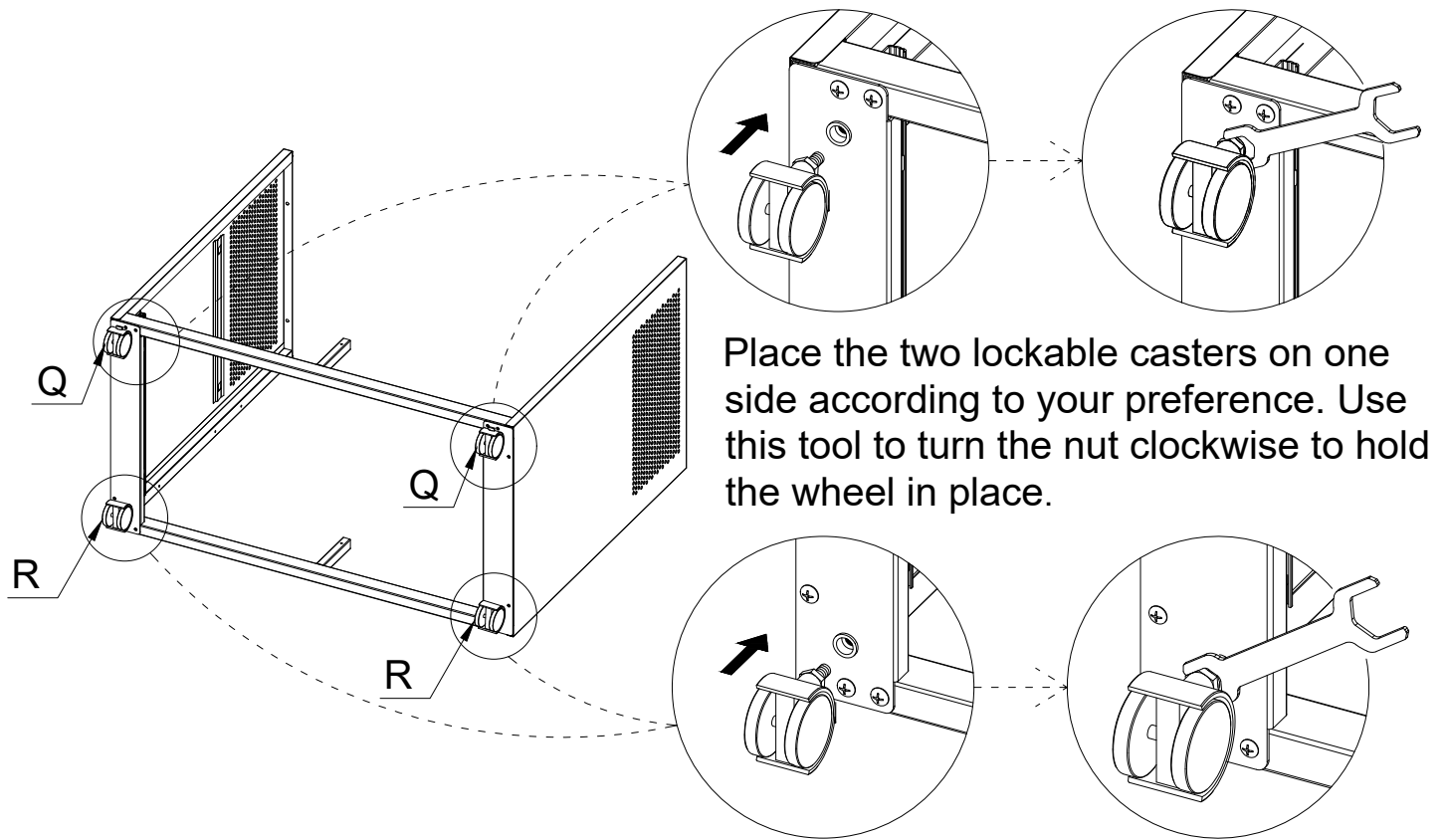

4

Place Part D into the frame, taking care to place the side with the screw holes facing backwards.

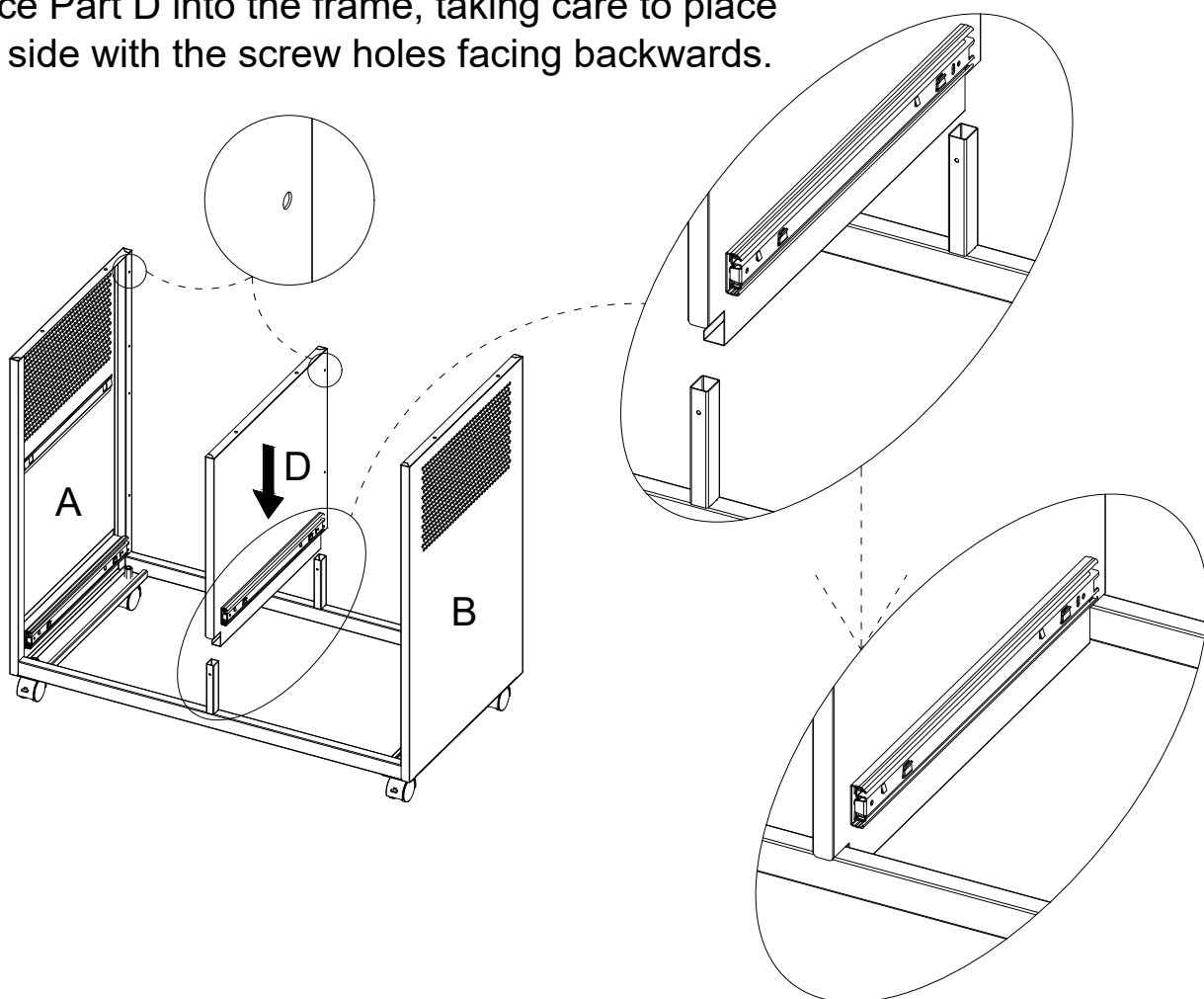

5 Put the rear wall E into the cabinet from above and put four screws to hold it in place.

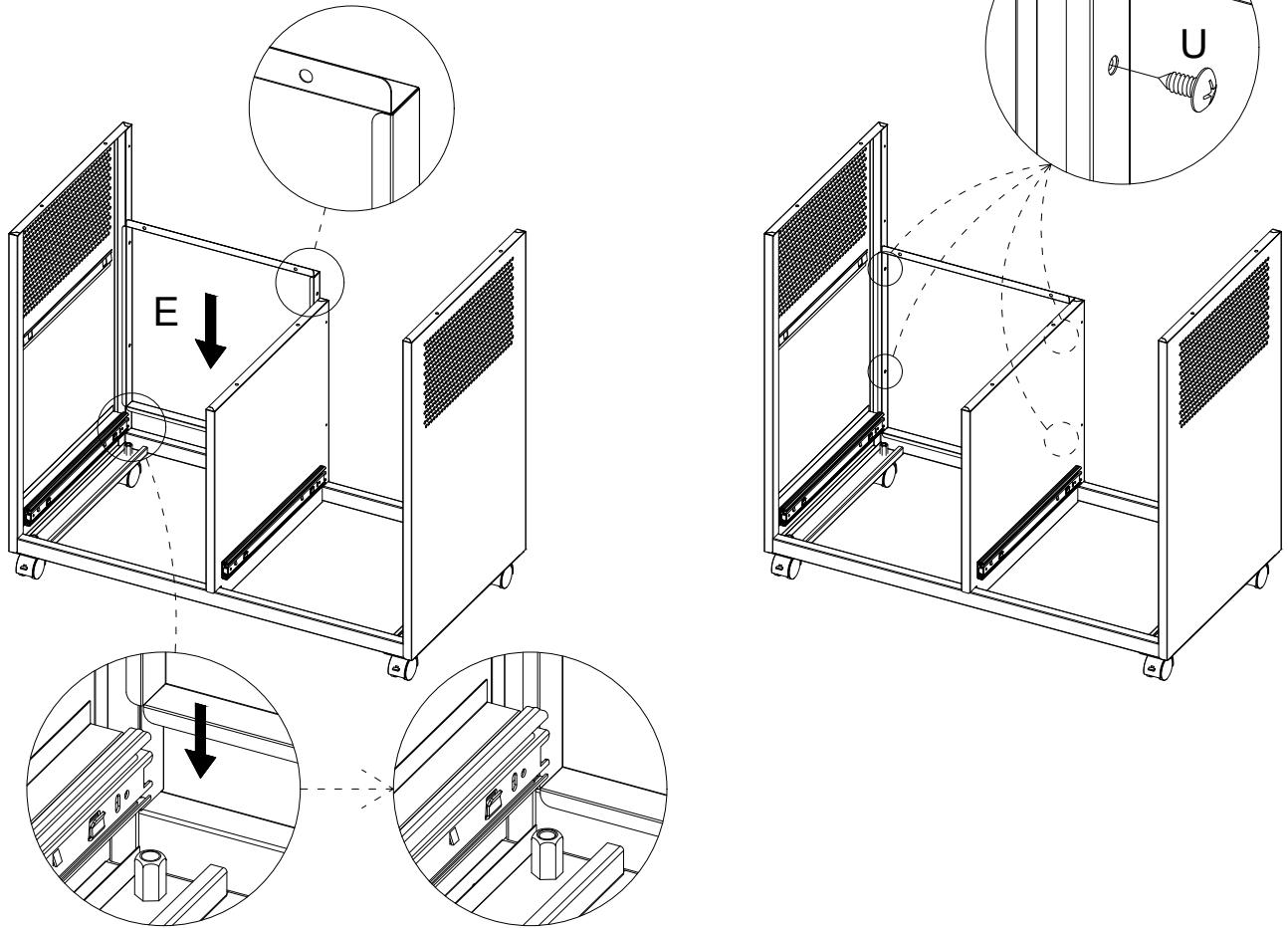

 U×4

6 Put the rear wall F into the cabinet from above and put four screws to hold it in place.

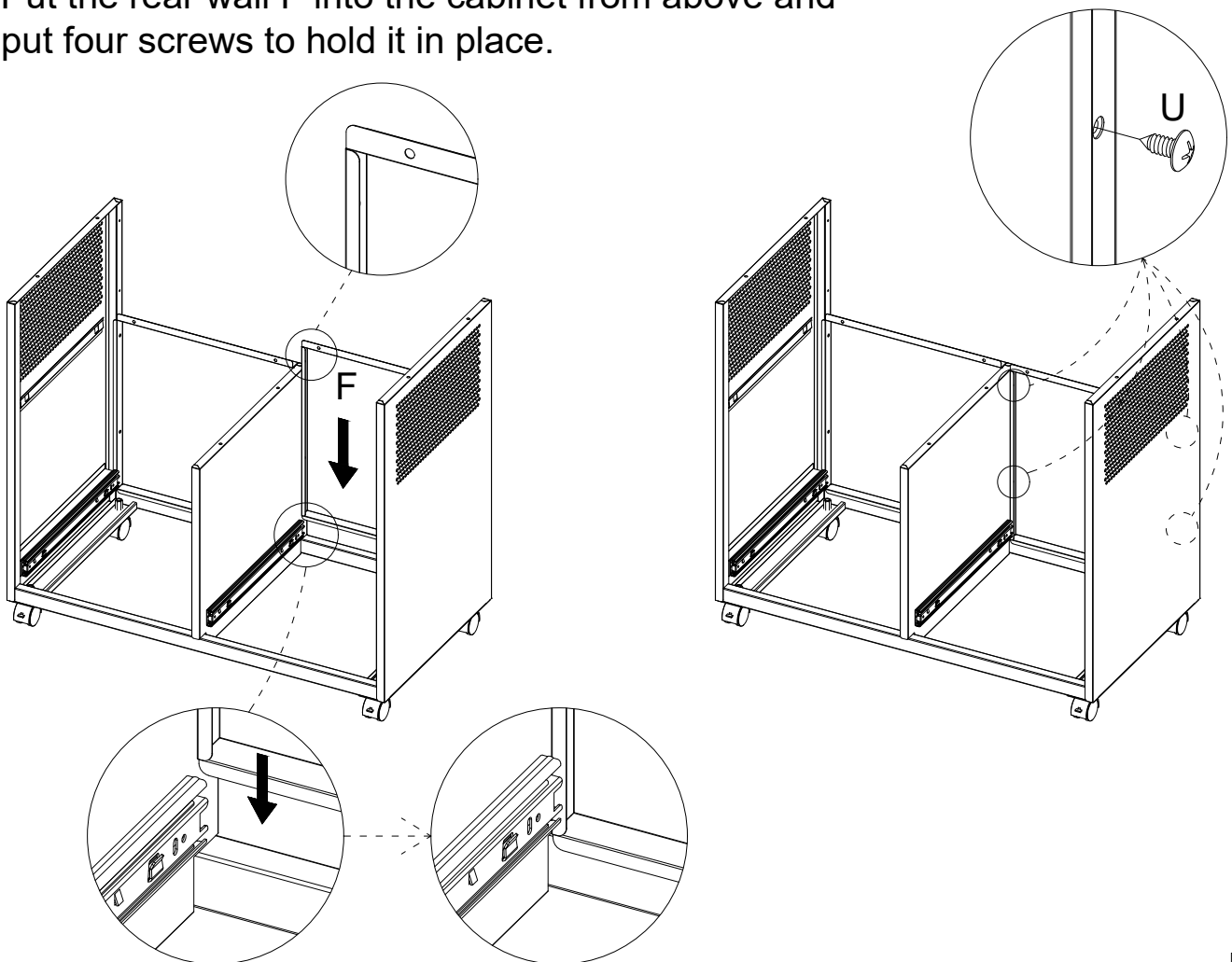

 U×4

7

When putting in Part I, place the side with the screw holes in the center on Part I toward the rear.

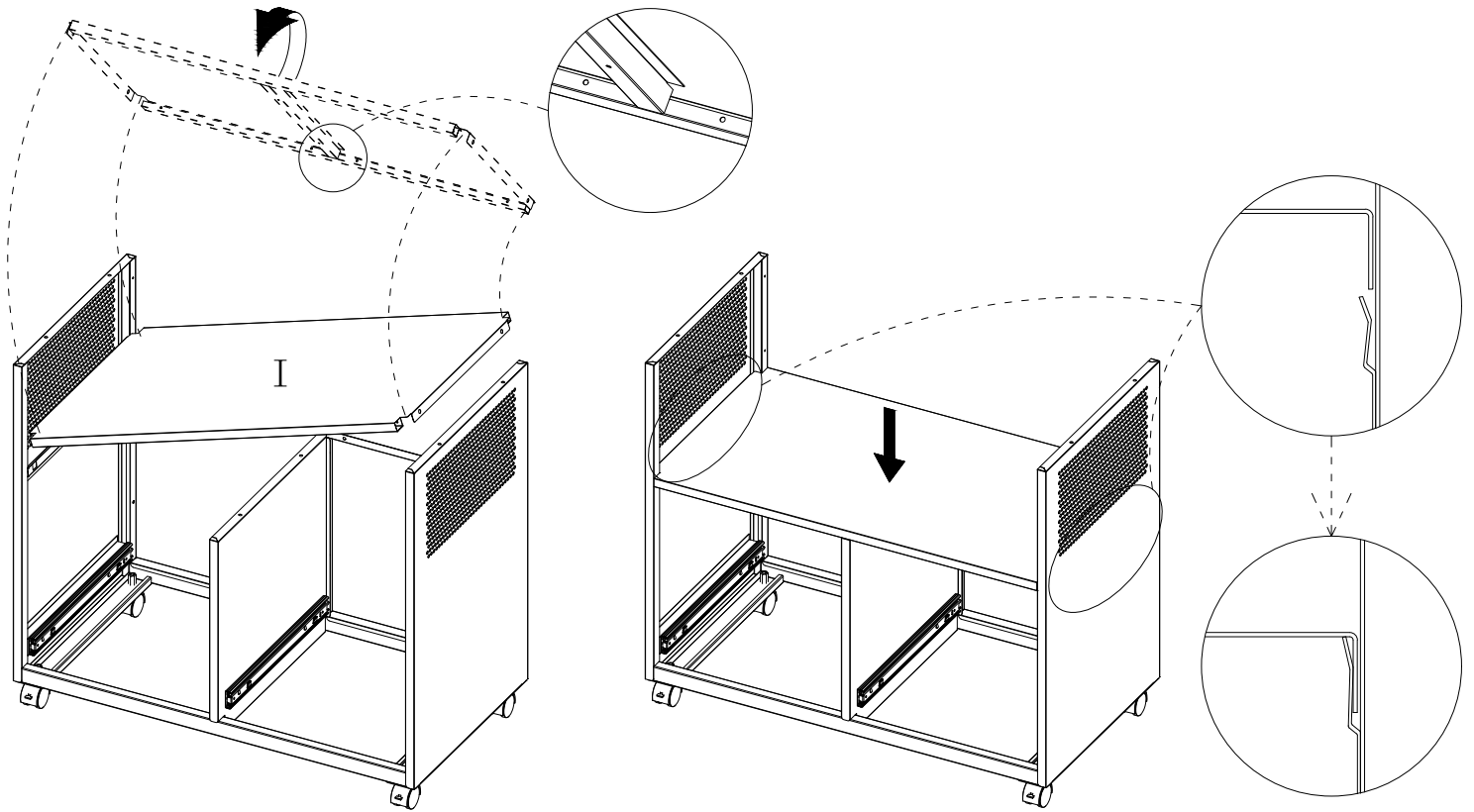

8

Fix Parts I with screws from the inside of the cabinet.

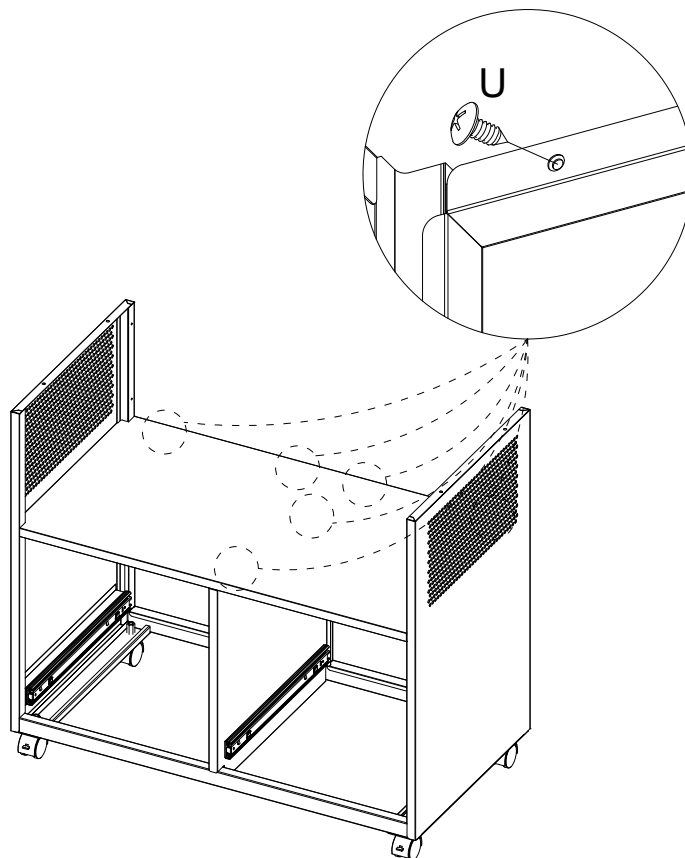

9

Fix Parts M with screws from the inside of the cabinet.

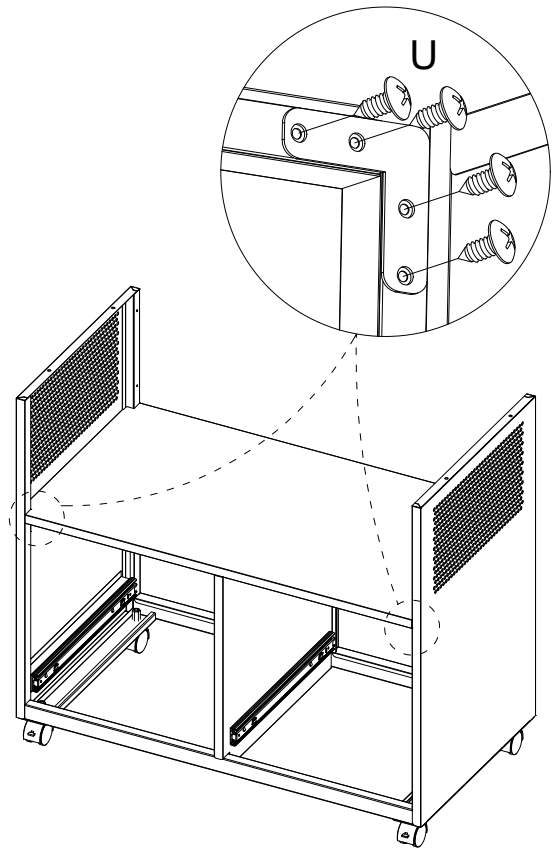
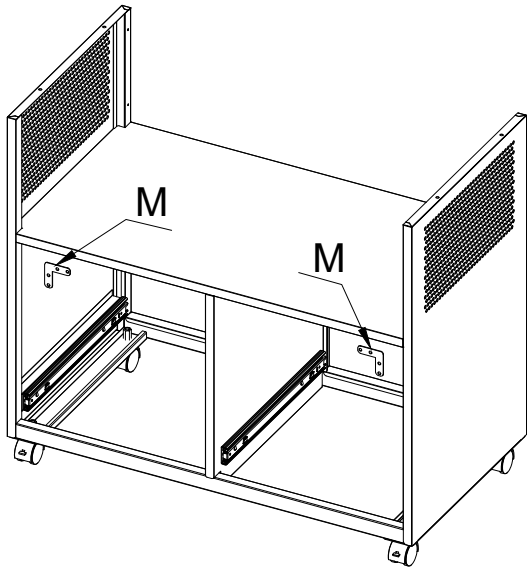

Ux8

10

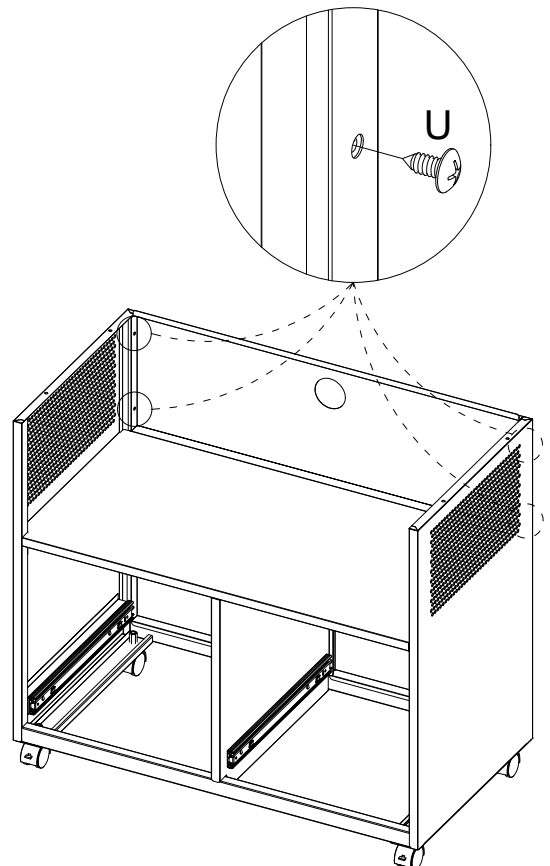
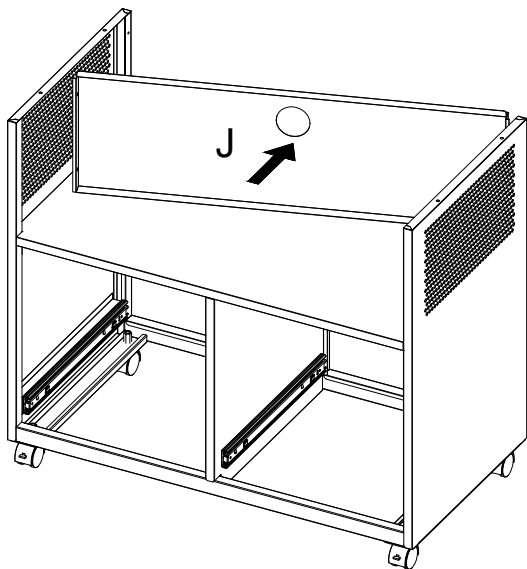

Ux4

11 Place the top plate G on top and put in seven screws to hold it in place.

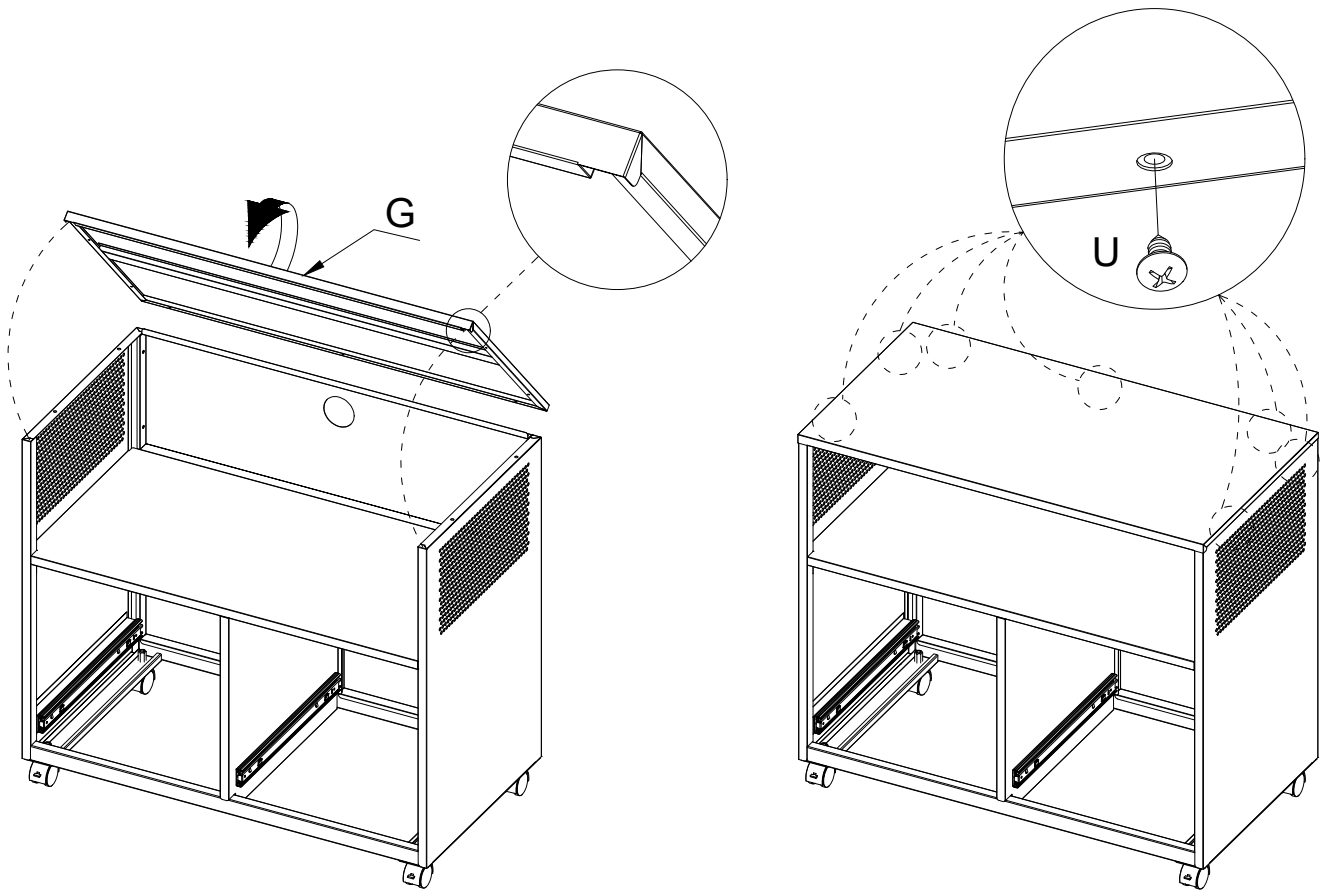

U×7

12 Insert the tabs at the bottom of the drawer faces H into the drawer body K and bend the tabs.

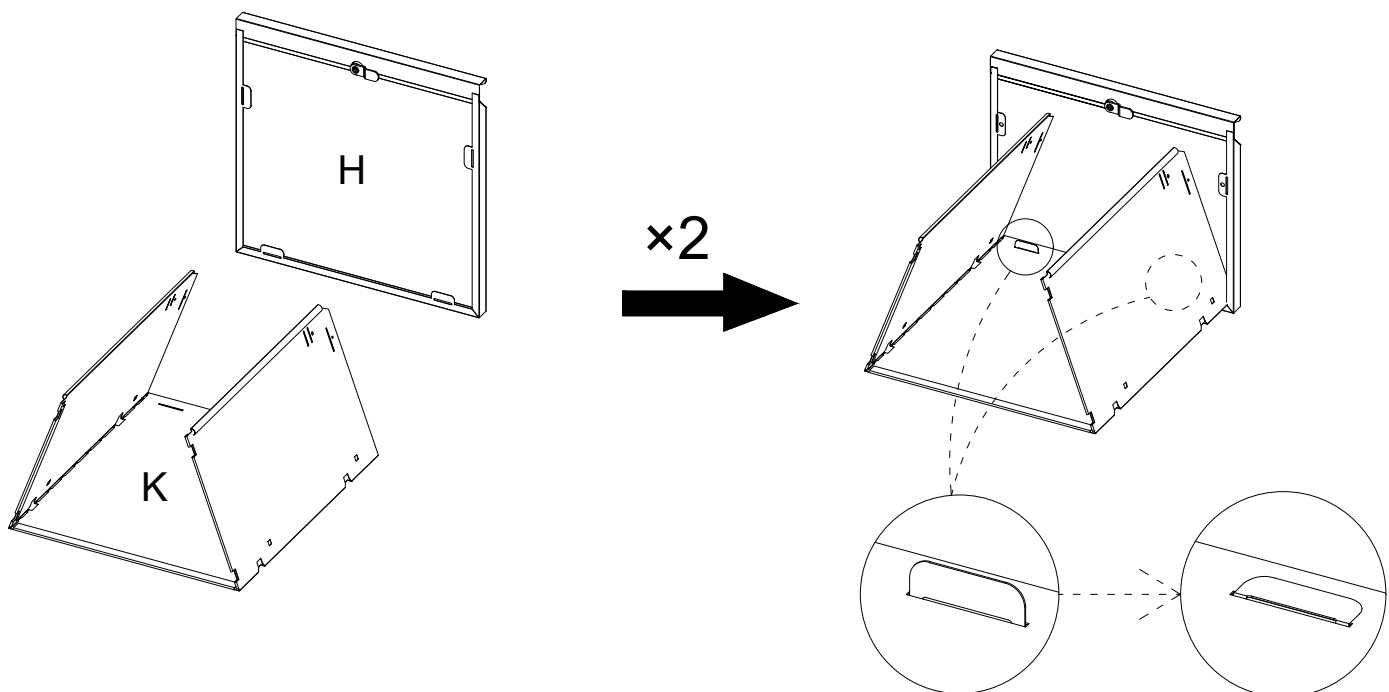

13

Bend the side walls of the drawer to vertical.

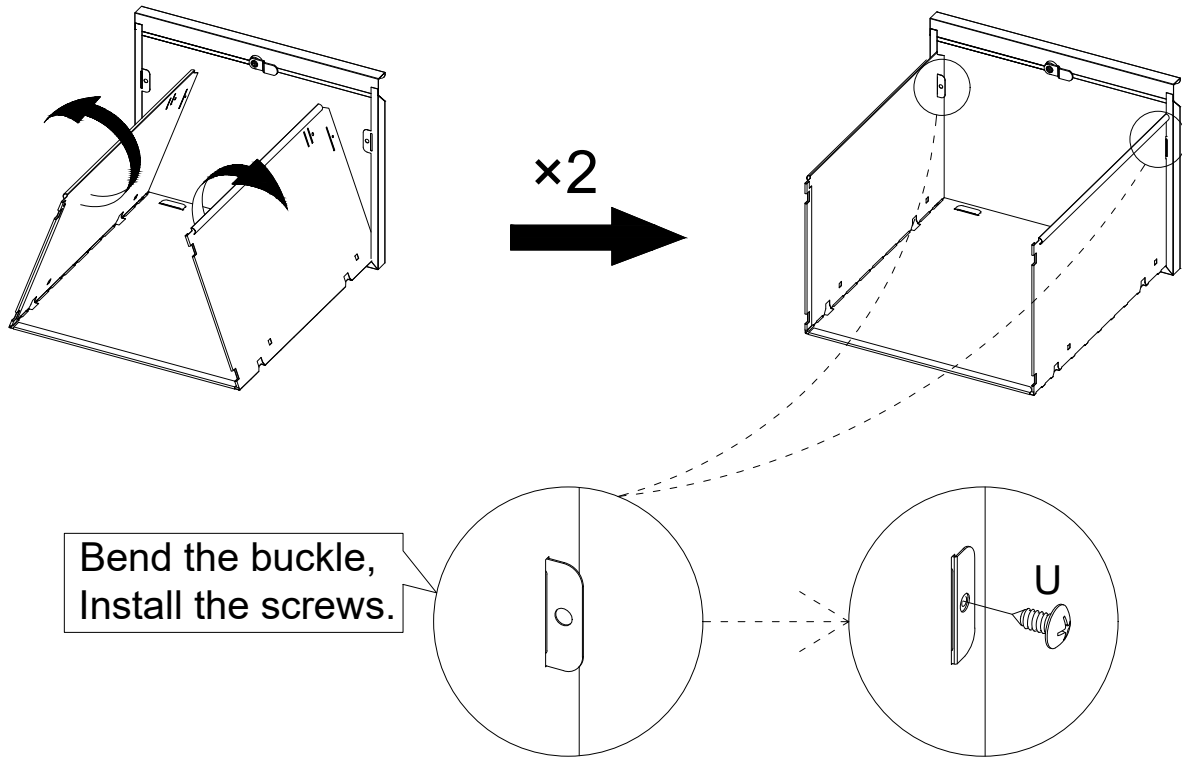

Ux4

14

Insert Part L from inside, and make sure that the little bits protruding from Part L are all inserted.

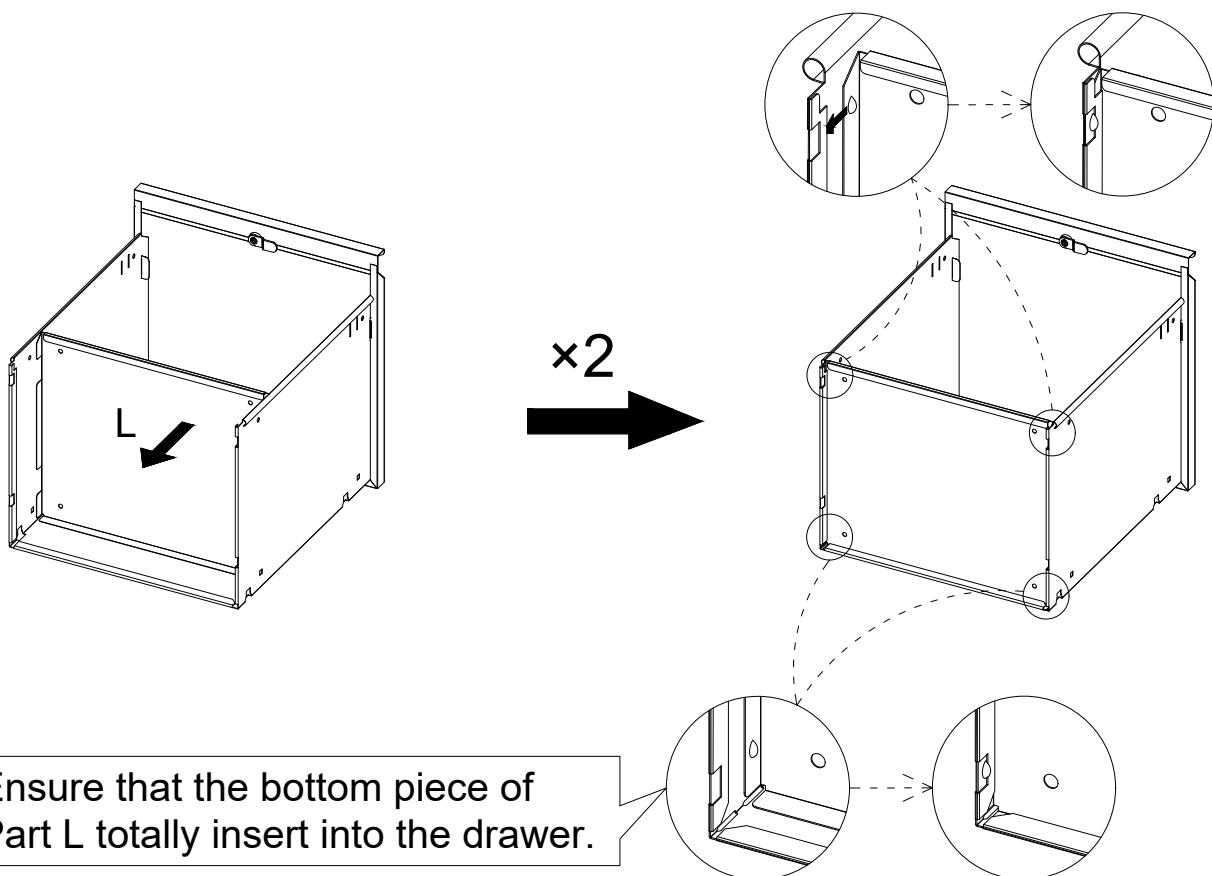

15

The file hanging bar can be put inside.

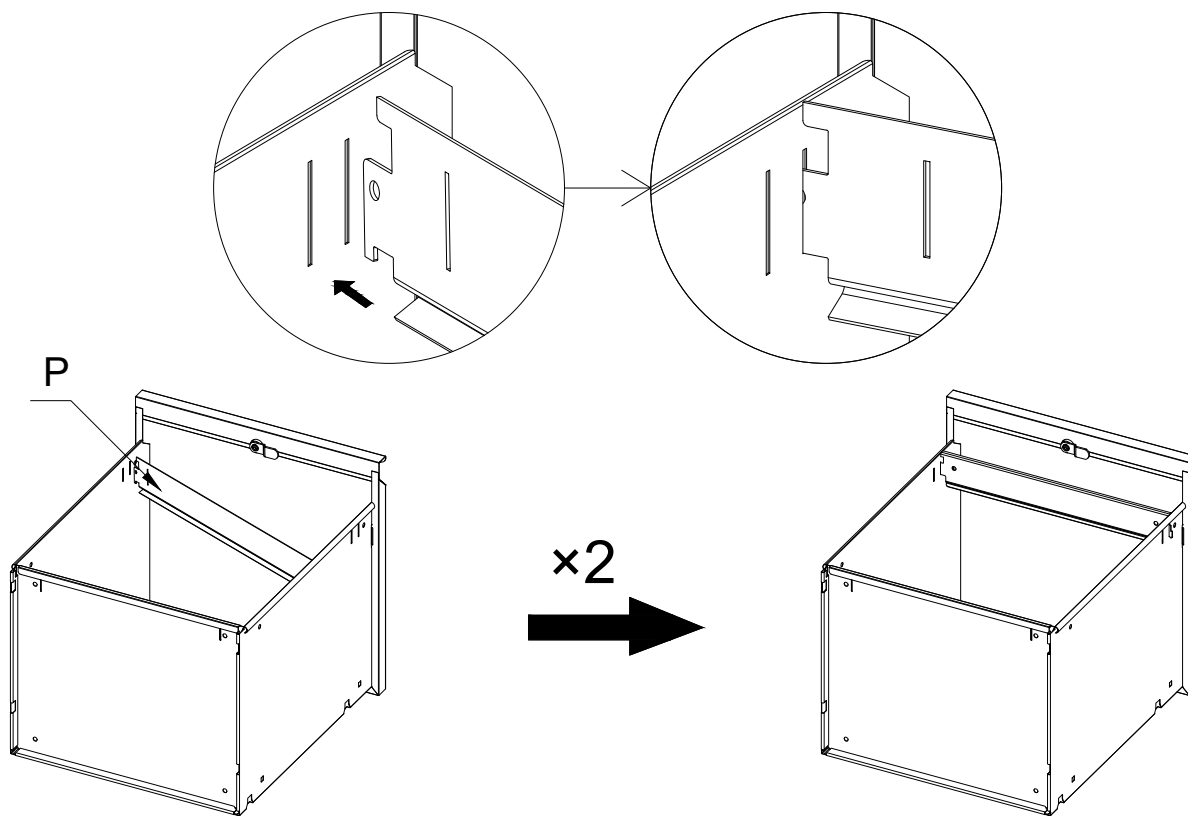

16

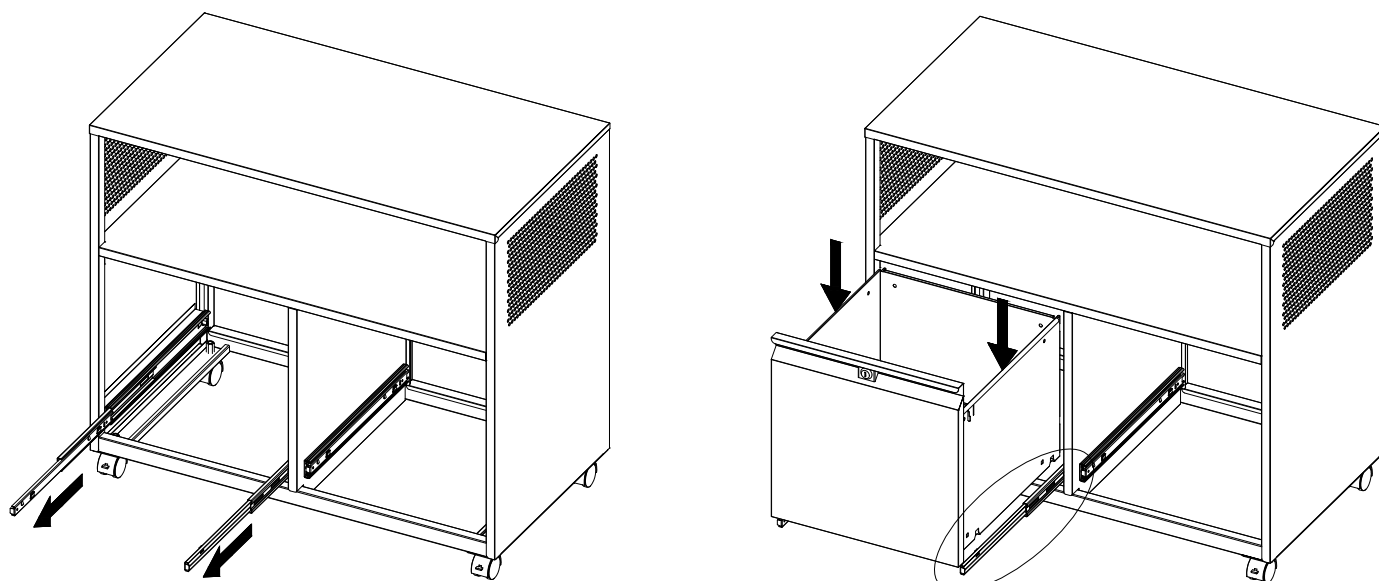

Pull out the two Guide Rails completely at the arrow position.

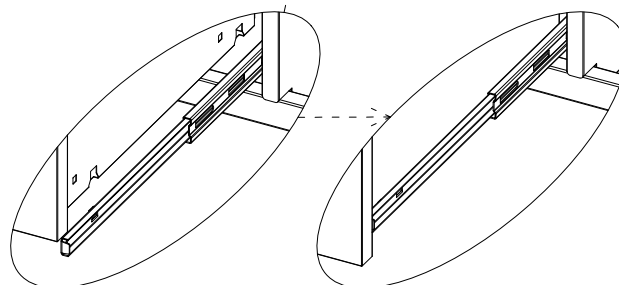

With two people lifting each side of the drawer, align the four divots on the bottom with the two rail clips on the rails on each side and insert them into the rail clips.

17

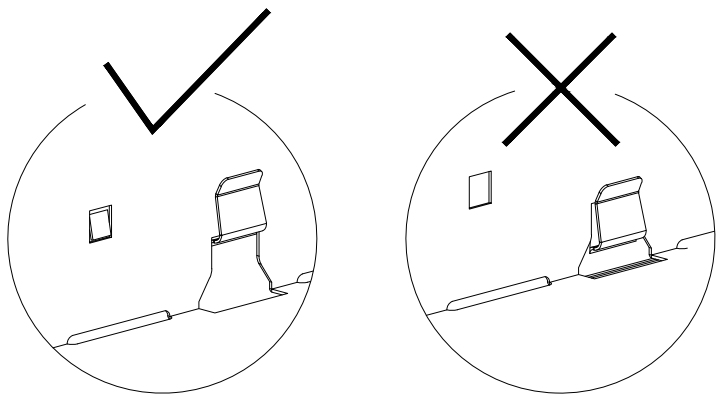

After placing the drawer on the rail, press the drawer base down hard enough, paying attention to check the position of the four clips inside until you hear a click four times, which means the drawer is in place.

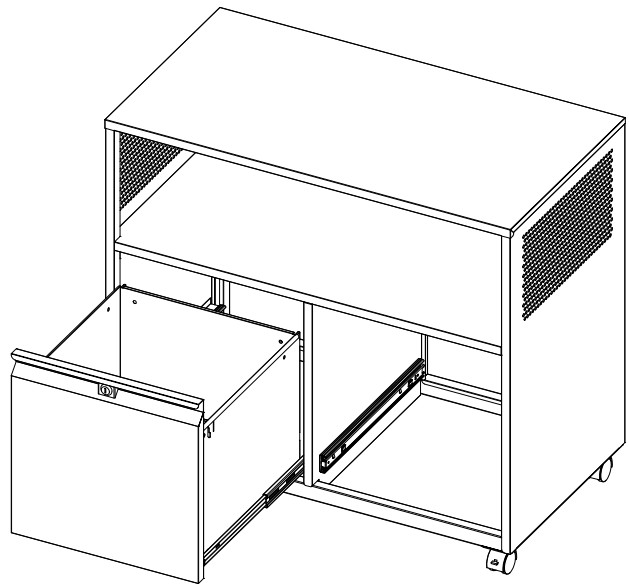

18

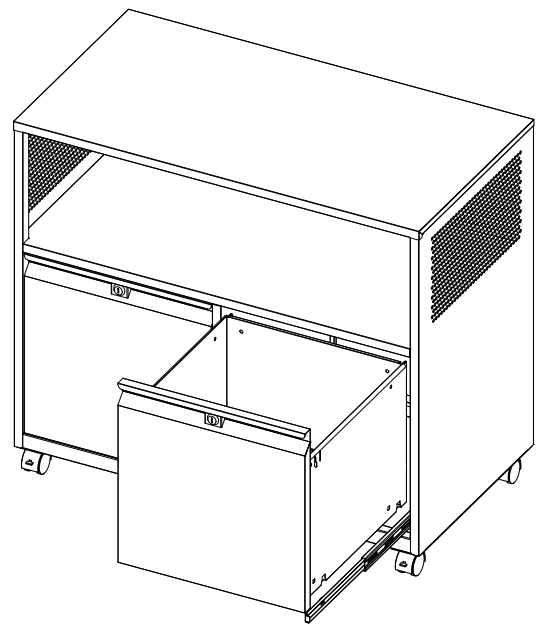
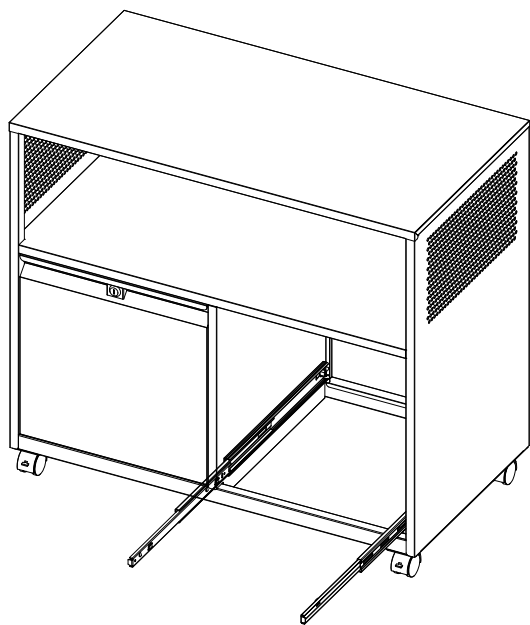

19 Hang hooks Z on the side of the cabinet according to your preference.

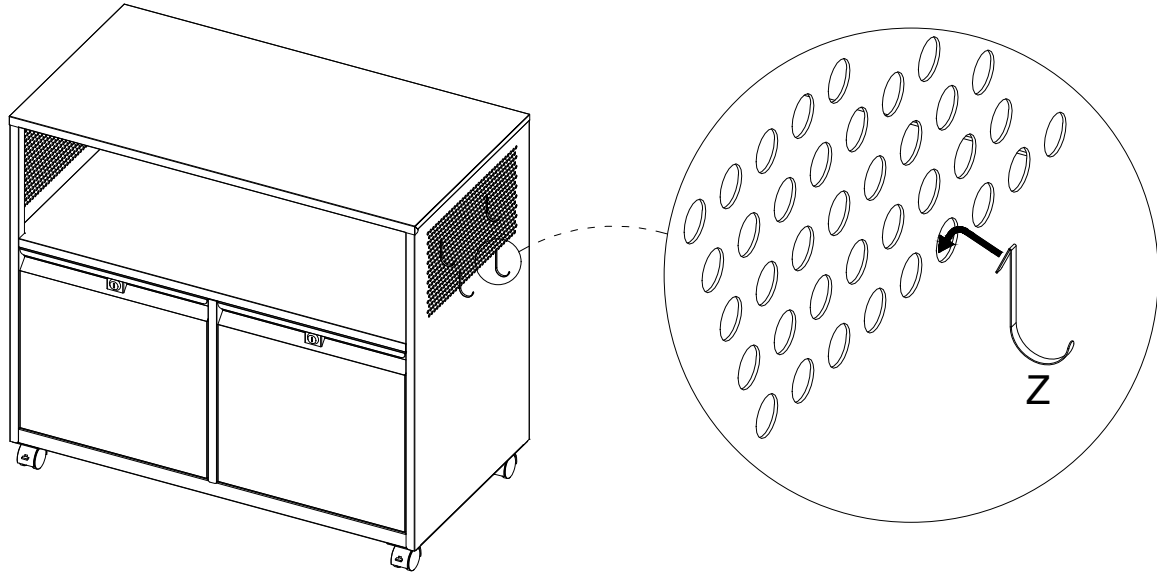

┌ Z×8

20

