







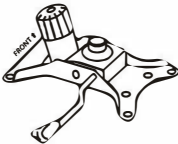

Assembly Instruction

Assembly Instructions for the Office Chair



Accessories List

<p>(1) Backrest</p> 	<p>(2) Seat Cushion</p> 	<p>(3) Base Plate</p> 	<p>(4) Base Tube</p> 
<p>(5) Air Rod</p> 	<p>(6) 4 Screws (M6X20mm)</p> 	<p>(7) 4 Screws (M6X30mm)</p> 	<p>(8) Hexagon Wrench</p> 

Notice

- Do not stand in this chair or use the chair as a step ladder use it as chair only. This chair is designed for one person to use at a time.
- Do not use this chair unless all bolts, screws and knobs are firmly secured.
- Check all bolts, screws and knobs every 90 days. Tighten them if any are loose.
- Failure to follow these instructions may result in serious injury or death of yourself and people around you.
- Some of the parts are heavy or have sharp edges, please install them carefully to avoid hurting you and people around you.

Assembly Instruction

Please assemble in a wide and flat place.

Step 1

Pick up the Air Rod (5) and Base Tube (4) as shown. Insert the Air Rod (5) into the Base Tube (4). Then put it aside and we will use it in Step 4.

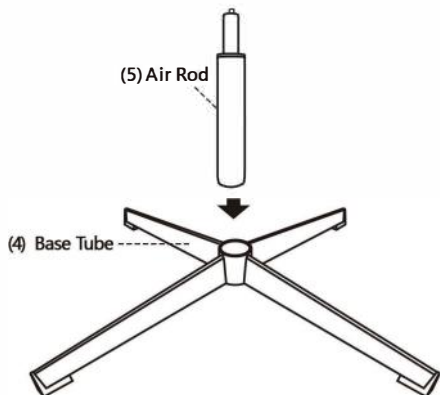

Step 2

Fix the Base Plate (3) to the bottom of the Seat Cushion (2). Tighten the Screws M6x20mm (6) with Hexagon Wrench (8) firmly.

*Caution: Make sure the 'FRONT' direction of Base Plate (3) and Seat Cushion (2) are the same.

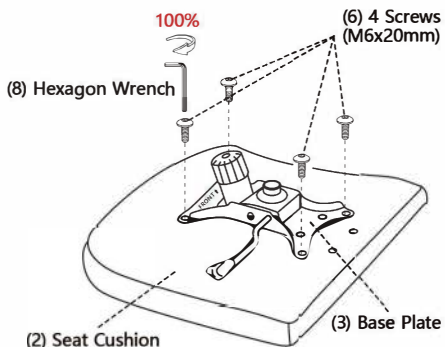

Step 3

Fix the bottom of the Backrest (1) to the back of the Seat Cushion (2). Tighten the Screws M6X30mm (7) with Hexagon Wrench (8) firmly.

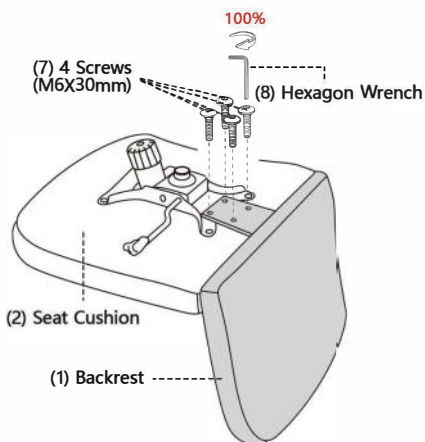

Step 4

Pick up the Air Rod (5) and Base Tube (4). There's a hole in the middle of the Base Plate (3). Press the Seat Cushion (2) from top to bottom, use your whole body's strength to insert it firmly, the assembly is complete now.

*Caution: If the Air Rod (5) doesn't insert to Base Plate (3) firmly, it's likely to fall off when the chair rises up.

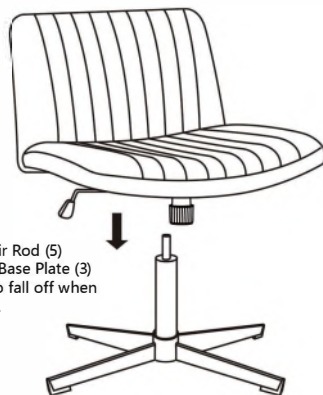

Instructions for Use



Up and down adjustment

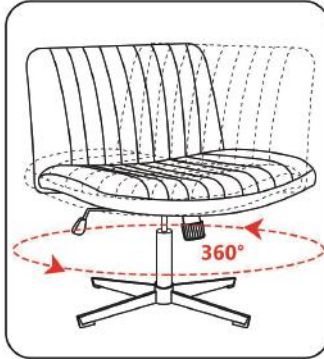

360° Rotation



Rocking Function

Thanks for purchasing our products. Please read this manual before assembly. And please assemble in order. After the assembly, keep the instruction properly. Make sure all the parts are included (8 kinds in total).

PRODUCT WARRANTY DETAILS

1. We hope you enjoy your new furniture as much as we enjoyed making it, if you have any comments or suggestion about our product, please feel free to share with us.
2. We do our best to ensure your furniture arrives without any problems, but occasionally mistakes happen-as humans we are imperfect beings. In the event that a part is damaged or missing, we really don't want you to go through the hassle of re-packaging your item and sending it back, we will be more than happy to provide you with replacement parts for free.
3. All your concerns will be taken good care of by our CUSTOMER SERVICE TEAM. All returns must be shipped back in original boxes. Pictures may be required for some returns to ensure an item is not damaged prior to its return. Items received without original boxes may not be accepted or may increase your return processing time.