

Installation & Assembly

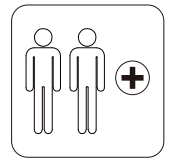

EN_IMPORTANT, RETAIN FOR FUTURE REFERENCE: READ CAREFULLY.

USING CAM LOCK AND QUICKFIT

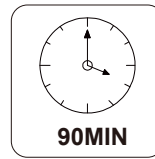
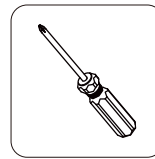
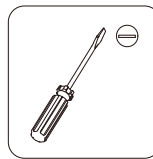
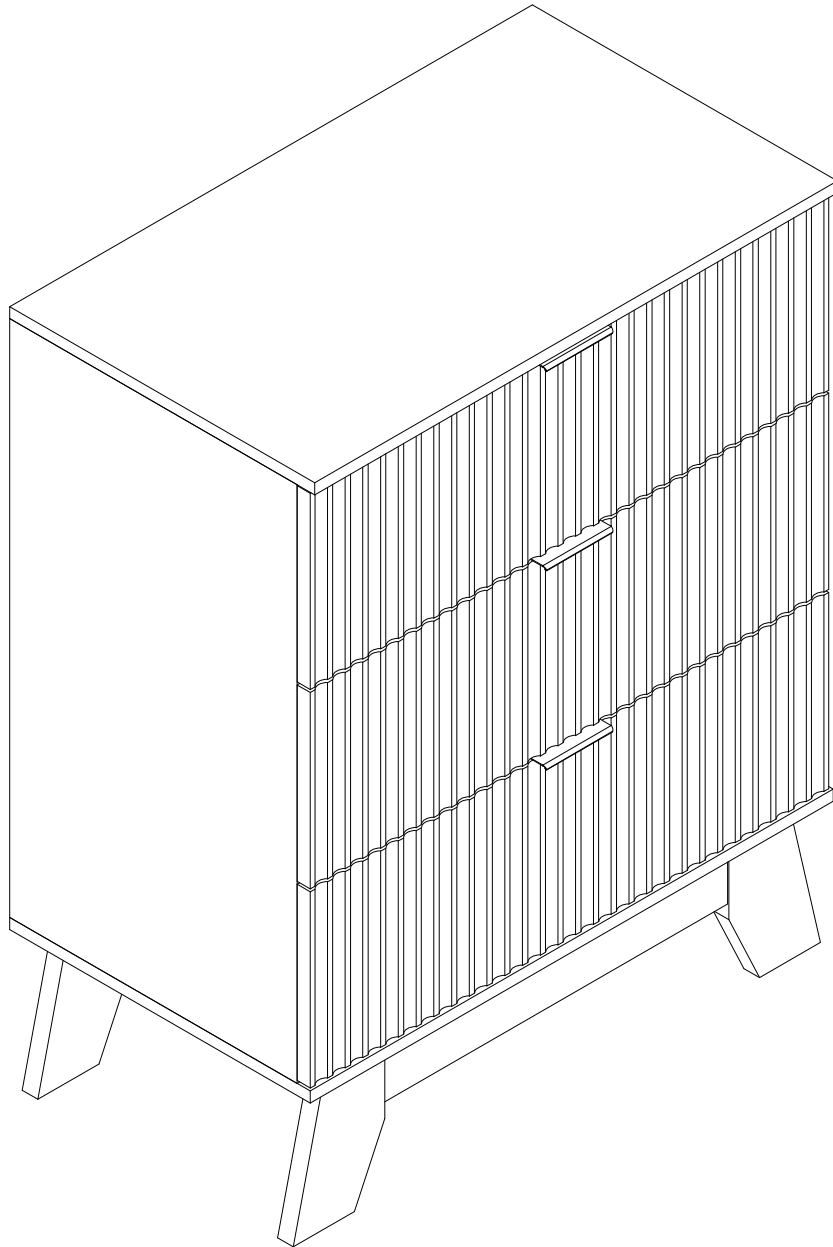
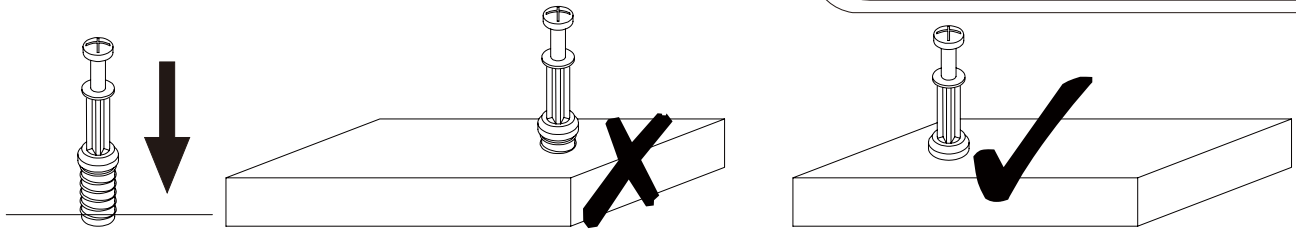

EN_QUICKFIT: Tighten quickfit until shoulder is flush with panel. Do not overtighten or undertighten.

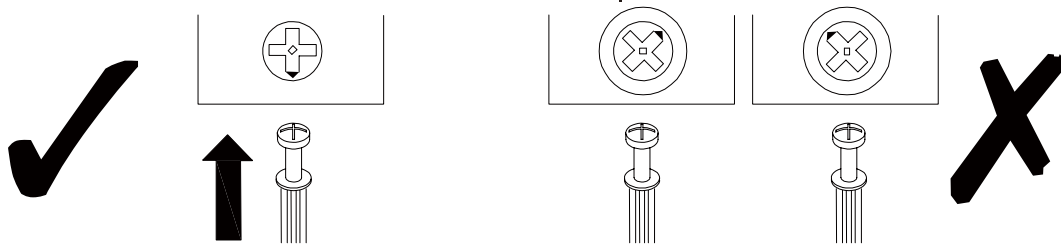

EN_CAM LOCK: When fitting cam lock, ensure starting position is correct before you insert connecting quickfit.

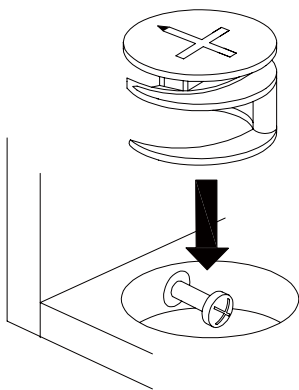

EN_Quickfit head should be in the centre of the cam lock when the two panels are joined.
Cam lock should be inserted before quickfit.

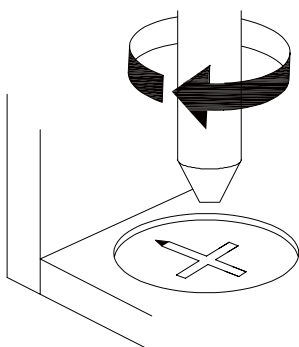





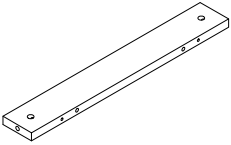
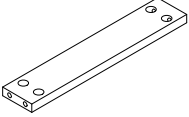
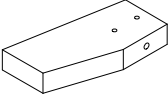
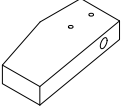
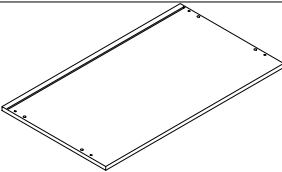
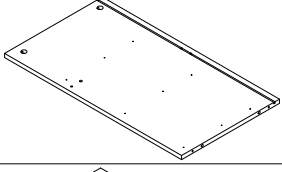
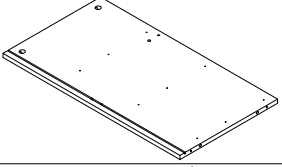
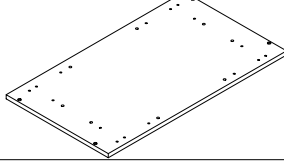
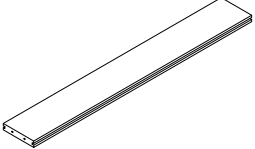
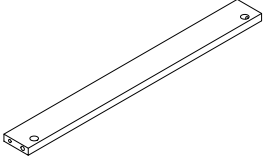
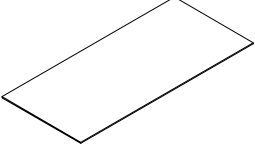

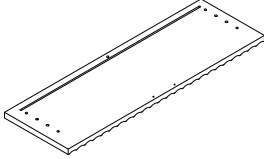
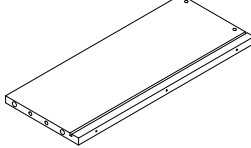
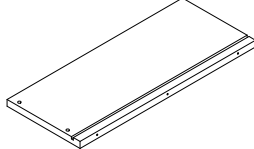
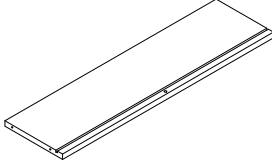
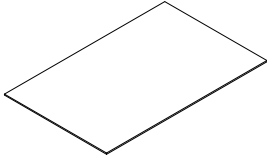
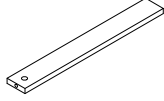
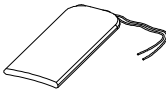

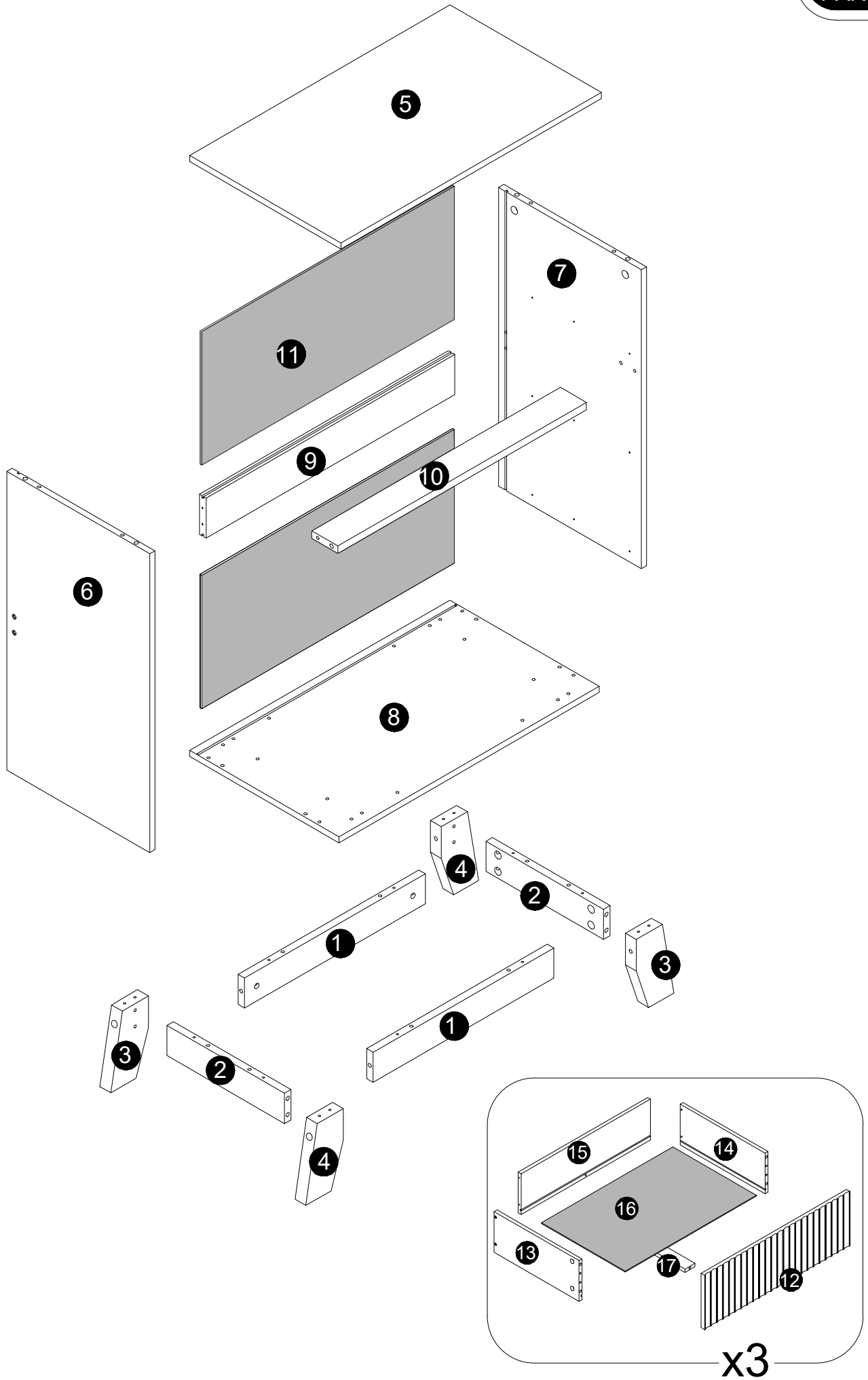







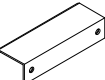

EN_Turn cam lock clockwise to tighten.

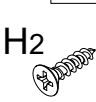

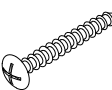
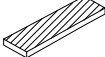
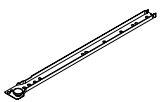
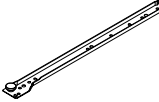
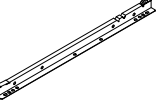
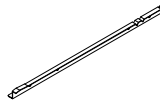

PACKING DELALS

NO.	PARTS	QTY	SPARE
①		x2	
②		x2	
③		x2	
④		x2	
⑤		x1	
⑥		x1	
⑦		x1	
⑧		x1	
⑨		x1	
⑩		x1	
⑪		x2	

NO.	PARTS	QTY	SPARE
⑫		x3	
⑬		x3	
⑭		x3	
⑮		x3	
⑯		x3	
⑰		x3	
			
	Hardware Kit		



 A x29 Ø6x35mm +2(spare)	 B x29 Ø15x10mm +2(spare)	 C x30 Ø6x30mm +3(spare)	 D x23 Ø4x35mm +2(spare)	 E x36 Ø3.5x12mm +3(spare)	 F1	 F2 x3	
 G x2	 H1	 H2	 I1	 I2	 J x2 Ø4x14mm	 K x16 Ø5x35mm +1(spare)	 L x4
 CL x3 L300mm	 CR x3 L300mm	 DL x3 L300mm	 DR x3 L300mm	 M1	 M2	 N x8	

 A x15	 B x15	 D x15	 C x12	x3	01
---	--	---	---	-----------	-----------

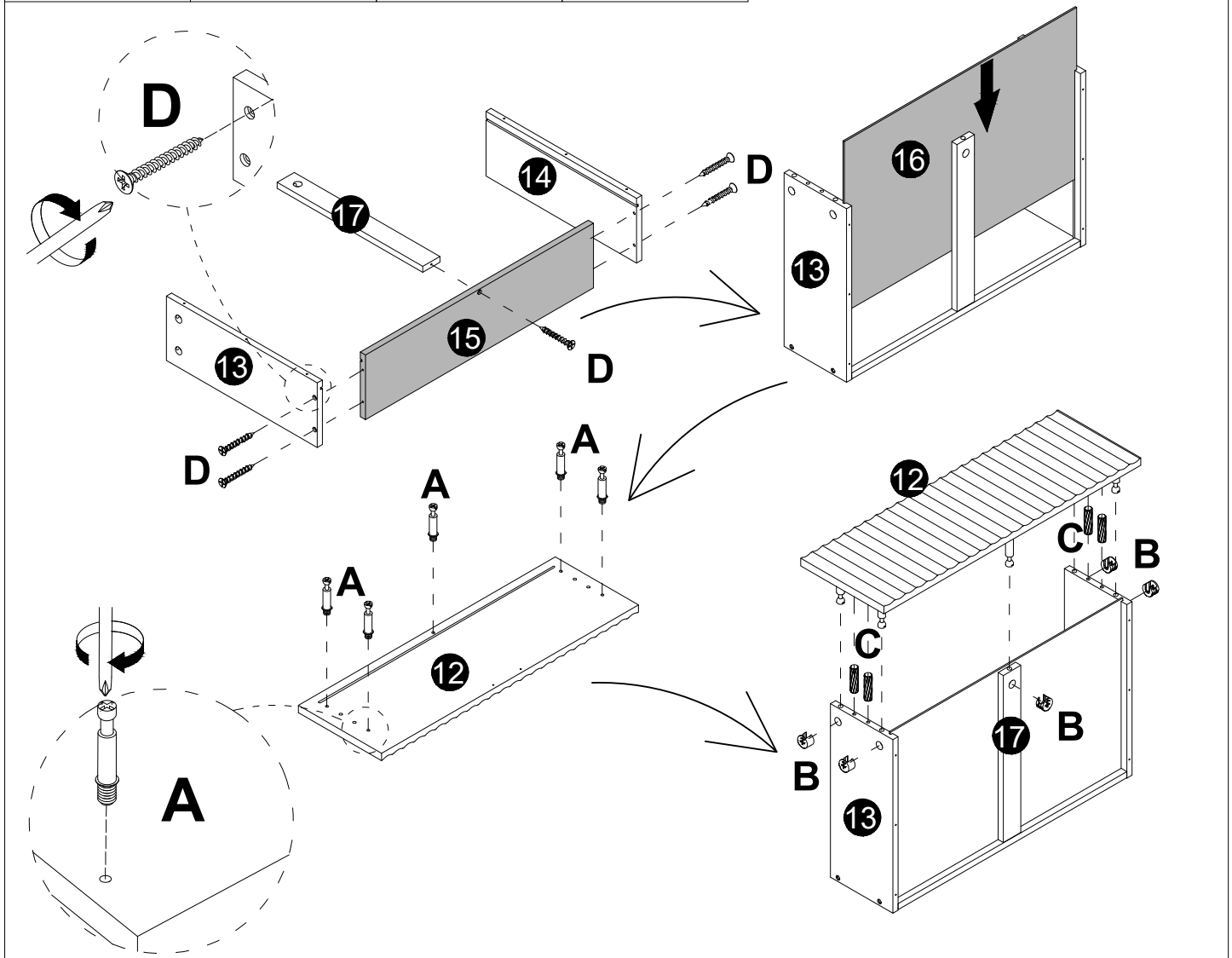

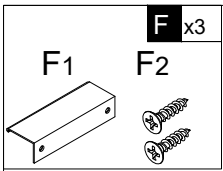

x3 02

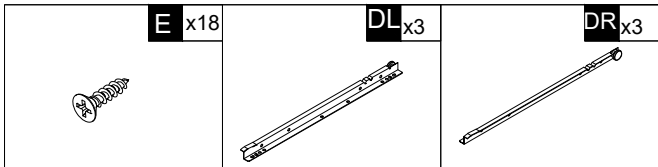
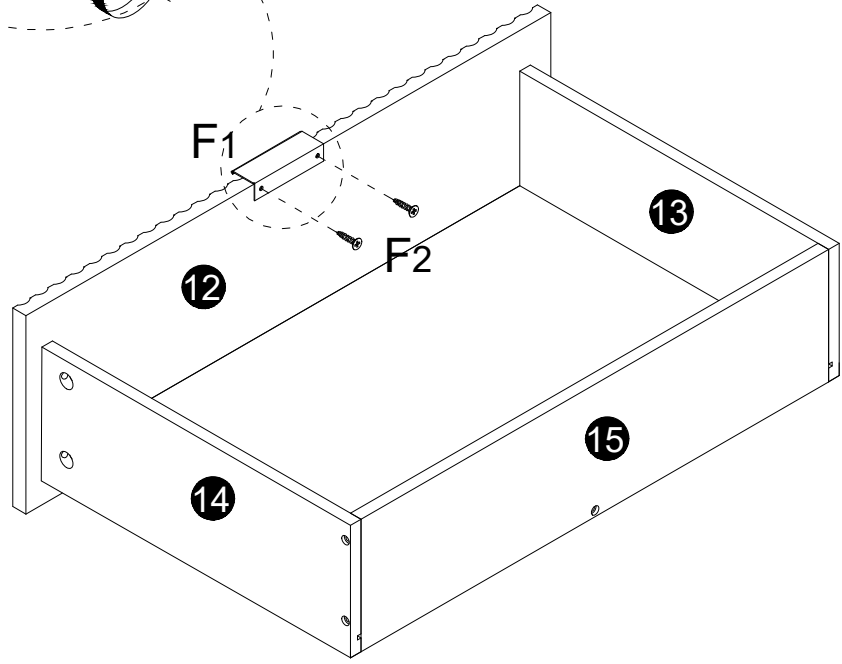
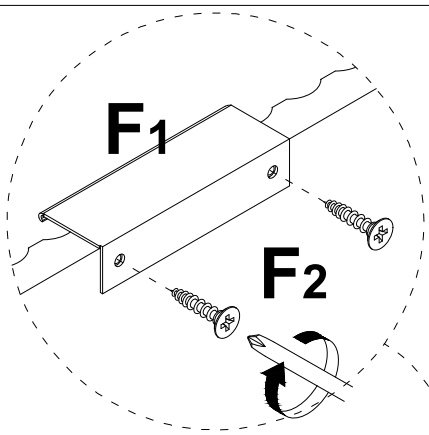

x3 03

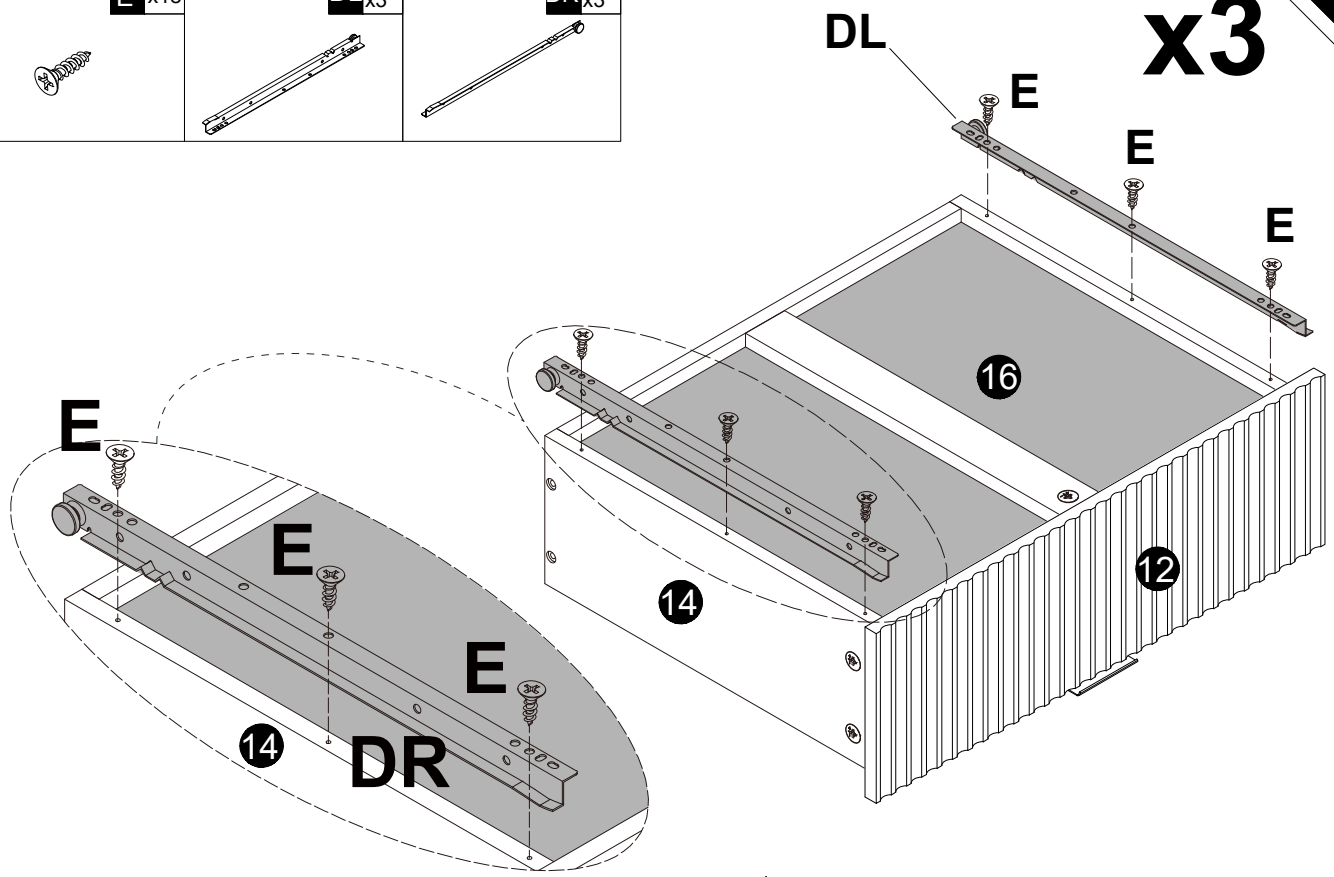

A x8

B x8

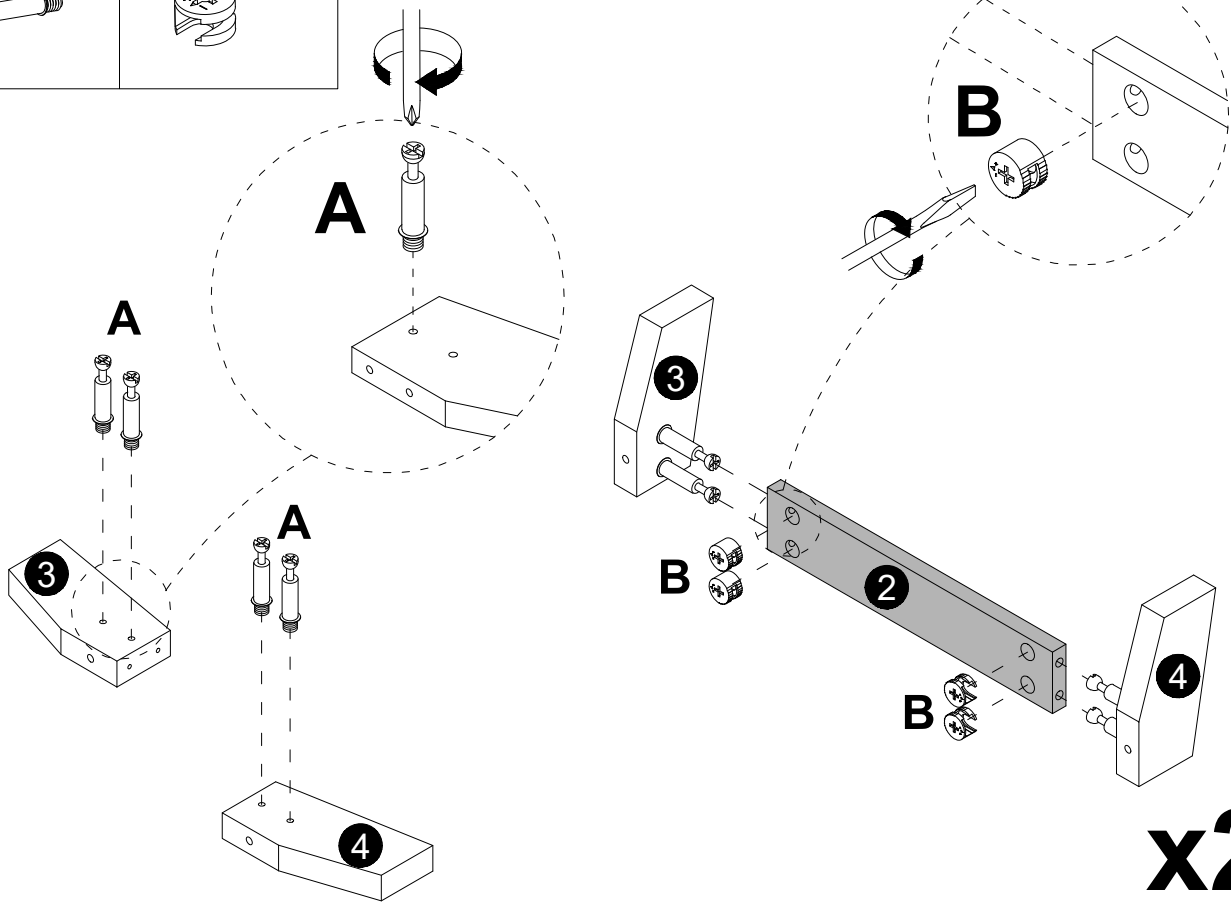

x2

M x4

M1

M2

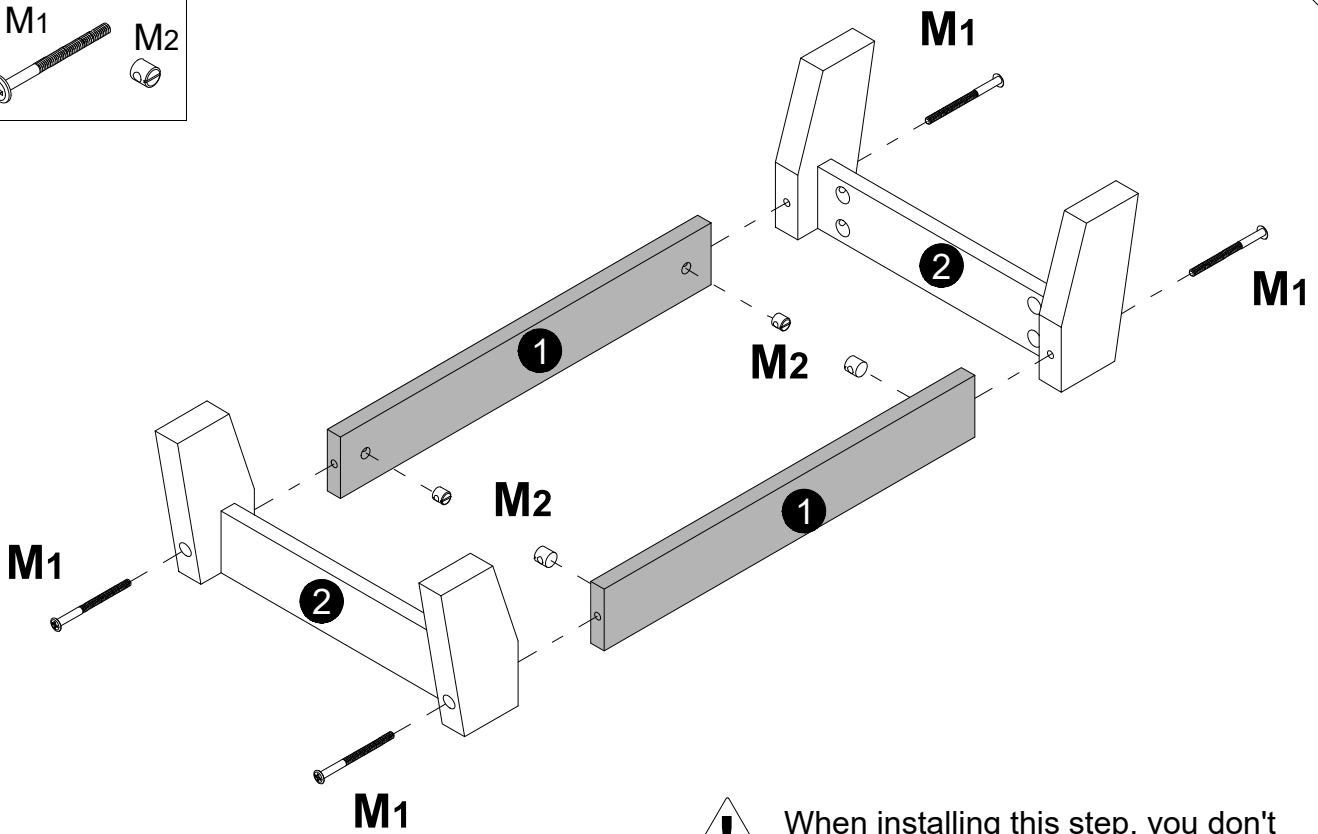
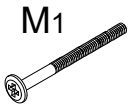

When installing this step, you don't need to lock it too tightly

C x8

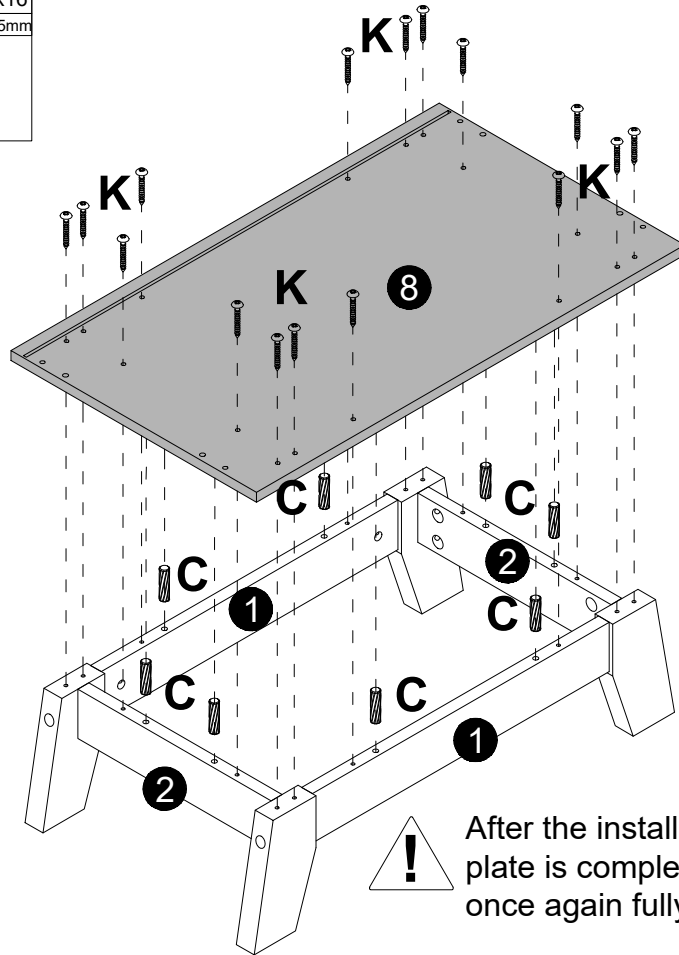
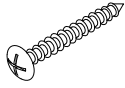
K x16
Ø5x35mm

After the installation of the No. 8 base plate is completed, the lock M bolt is once again fully fixed on the leg

L x4

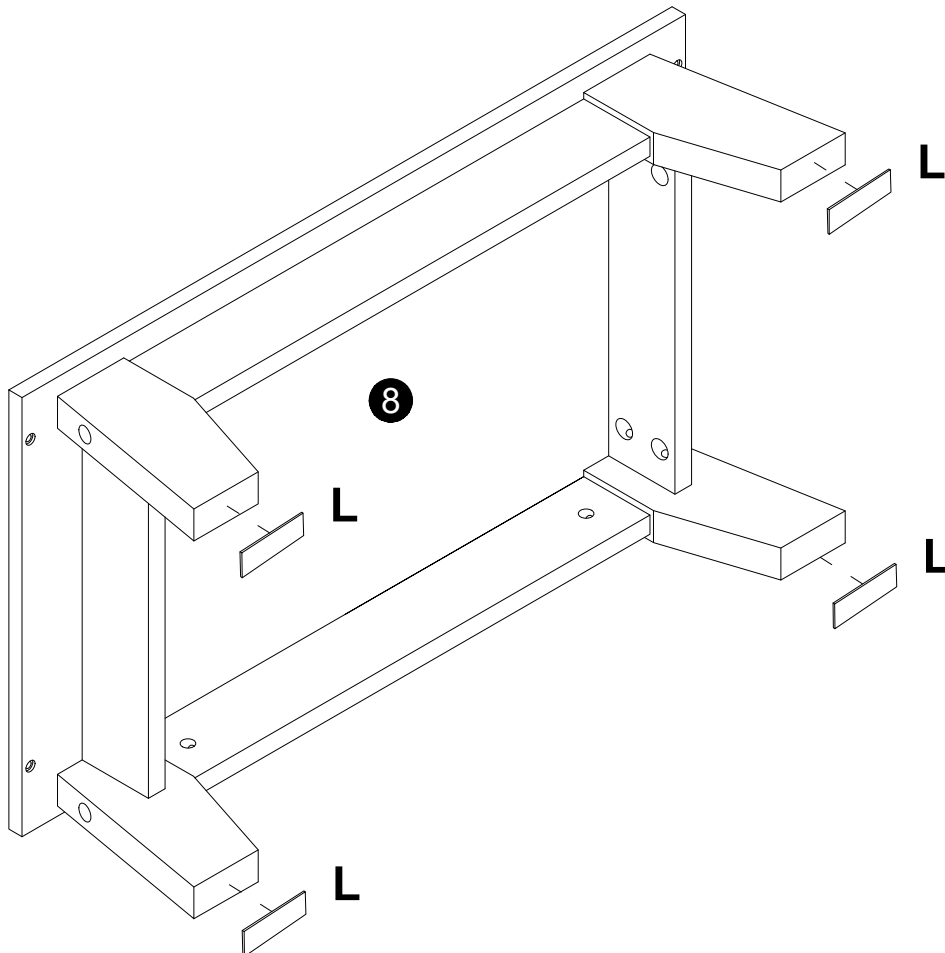
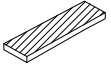

A x2

E x18

CL x3

CR x3

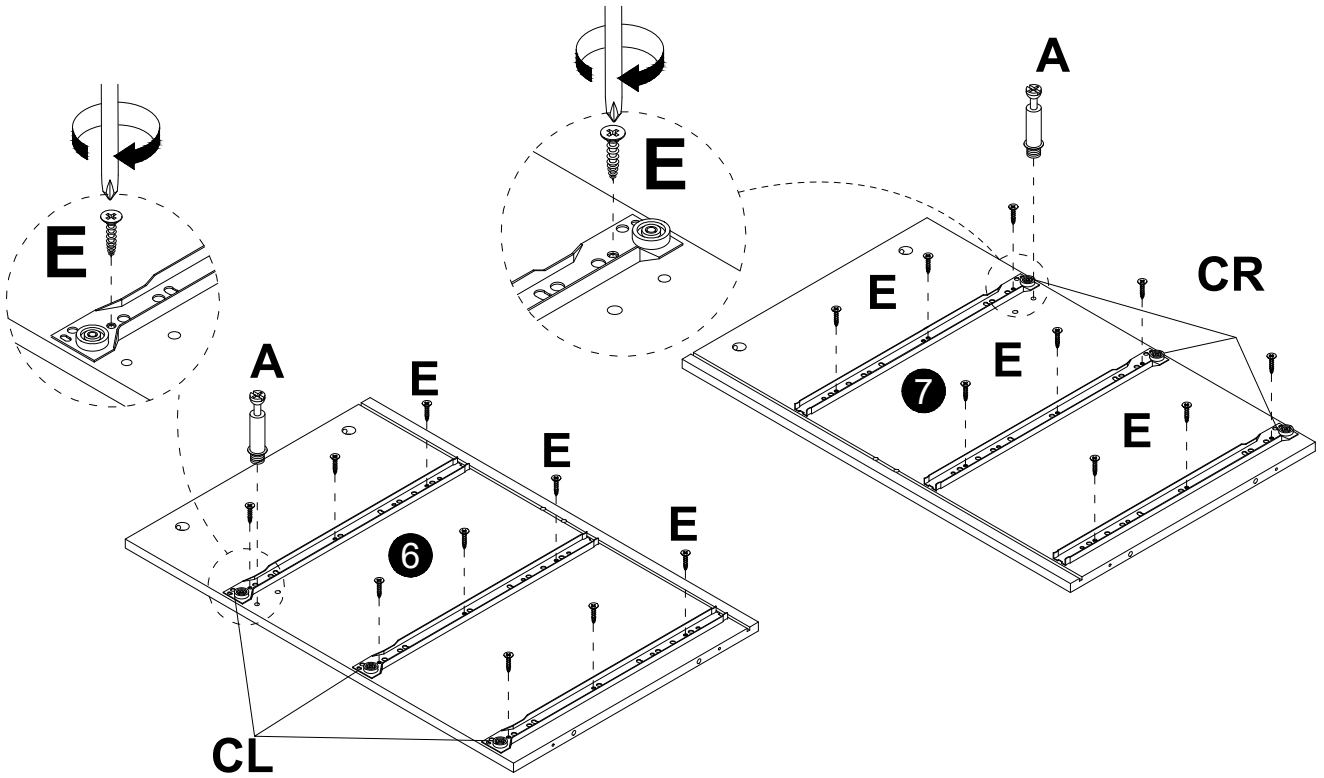
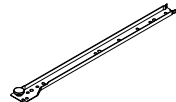
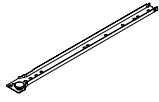
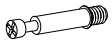

B x2

C x2

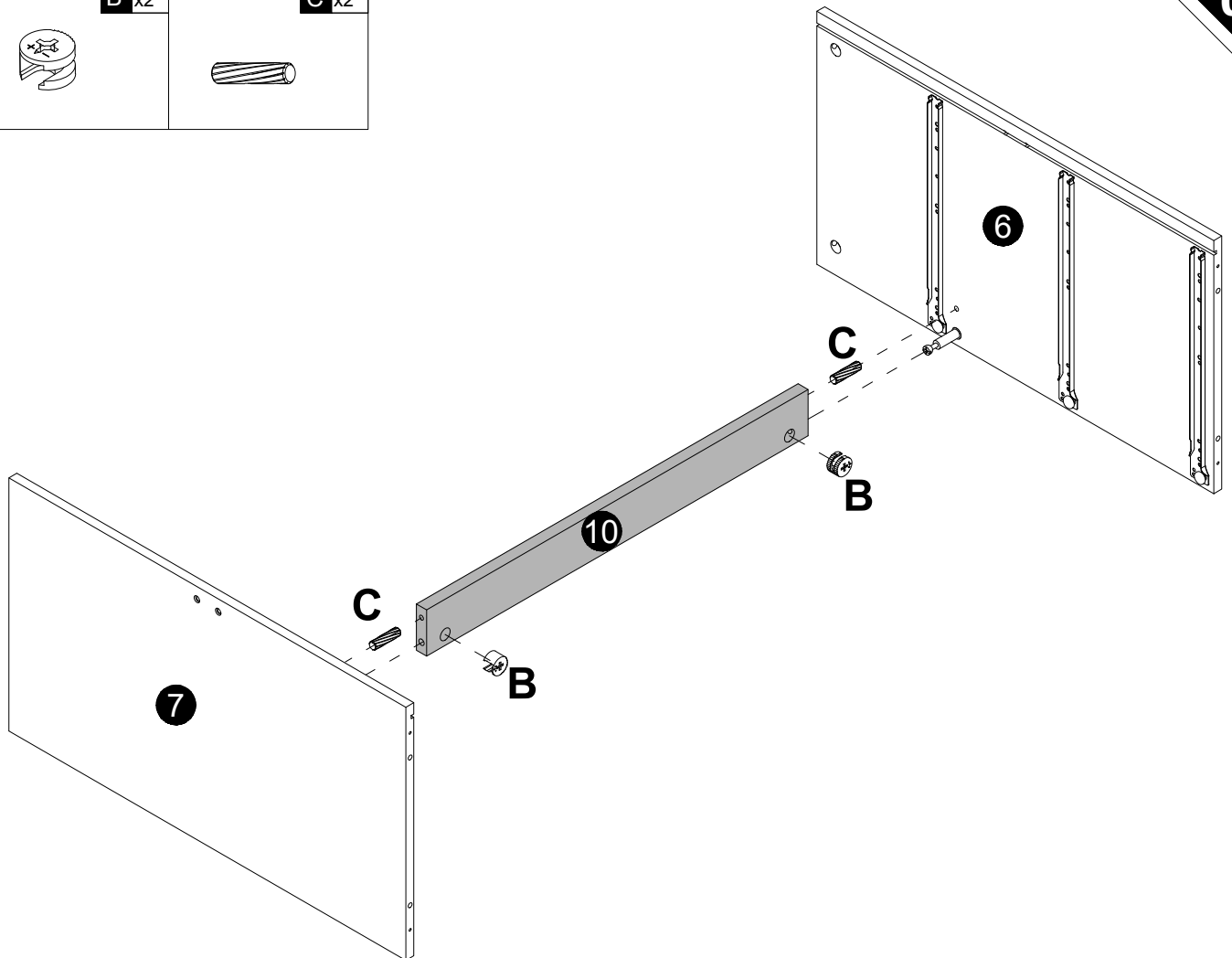

D x4

C x4

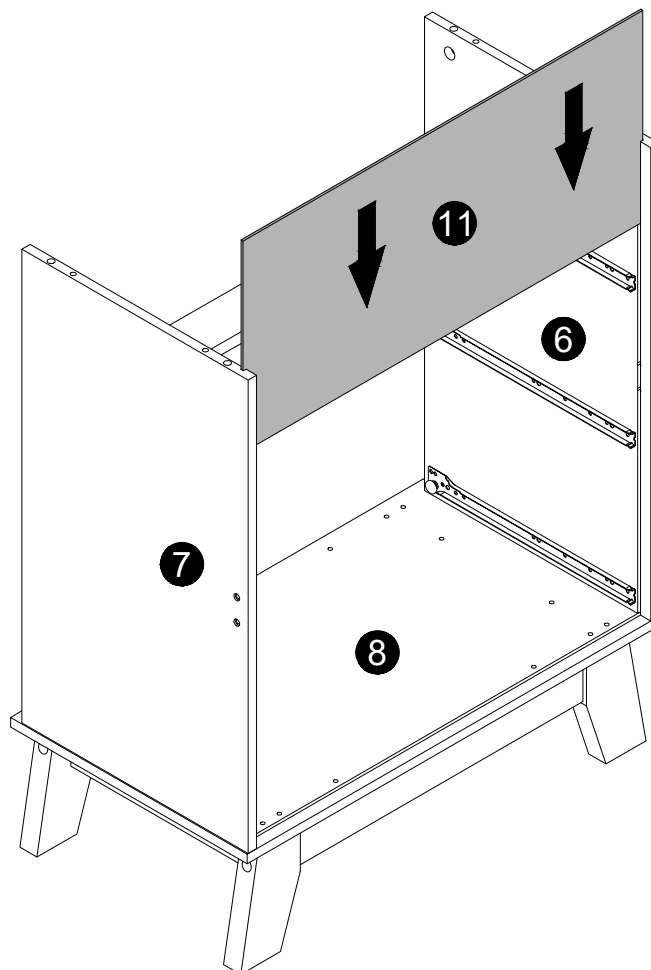
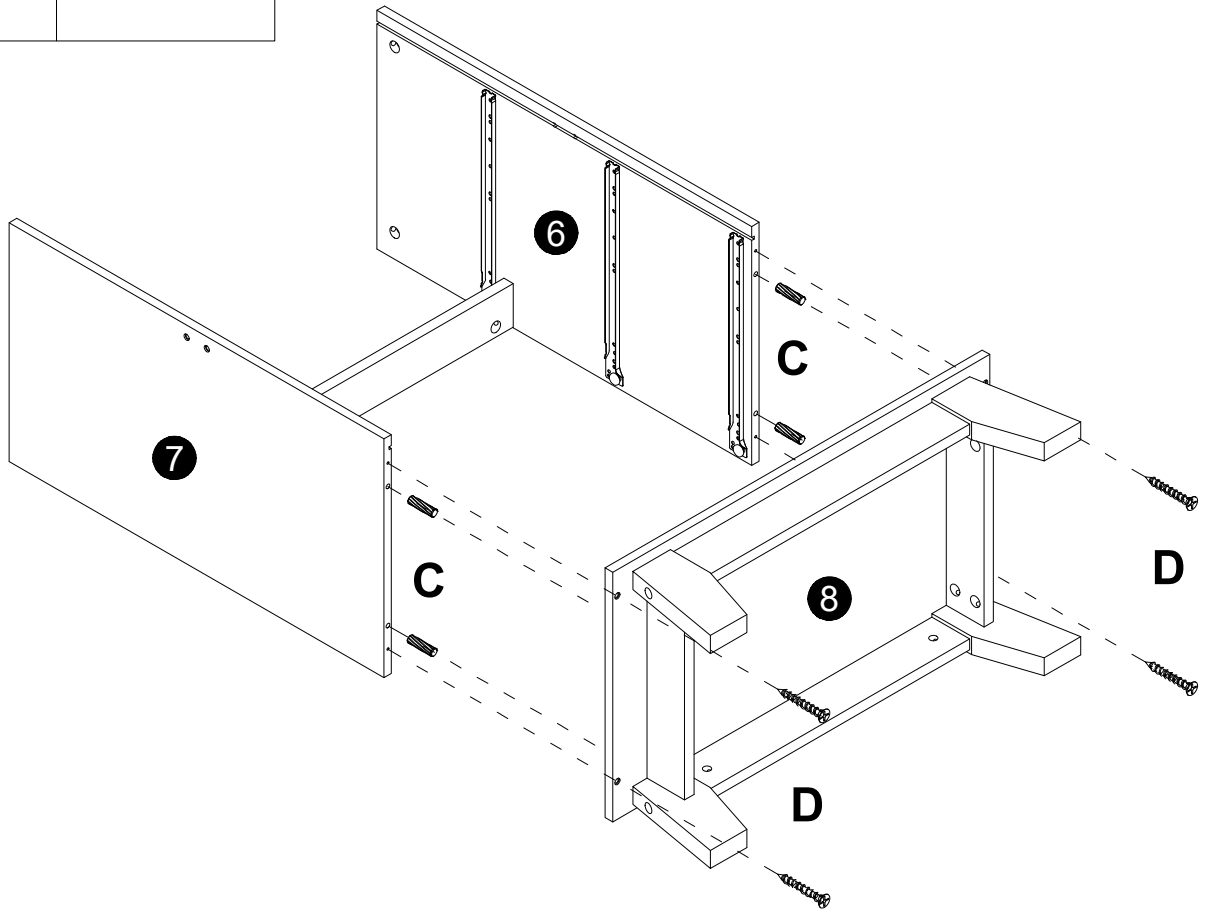
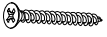

D x4



12

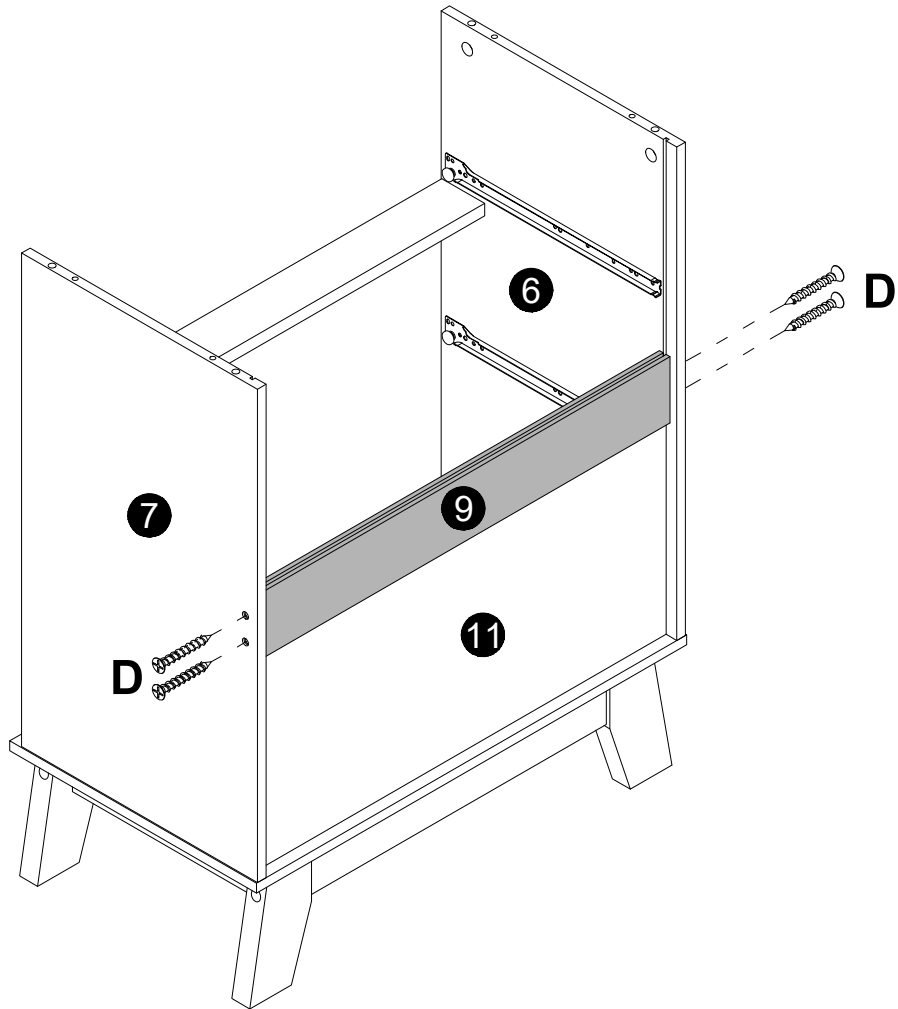

13

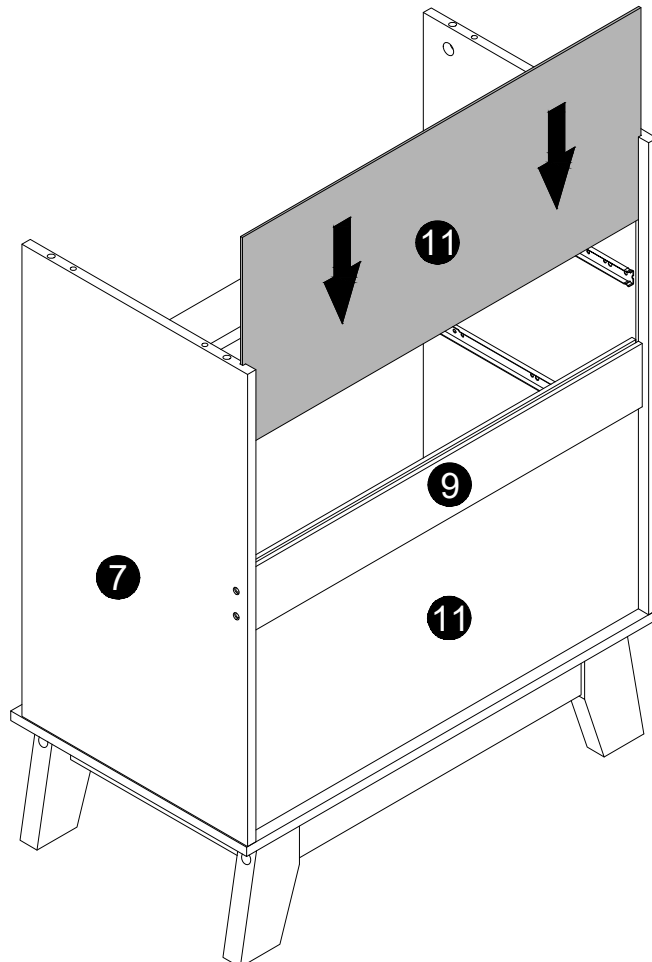

A x4

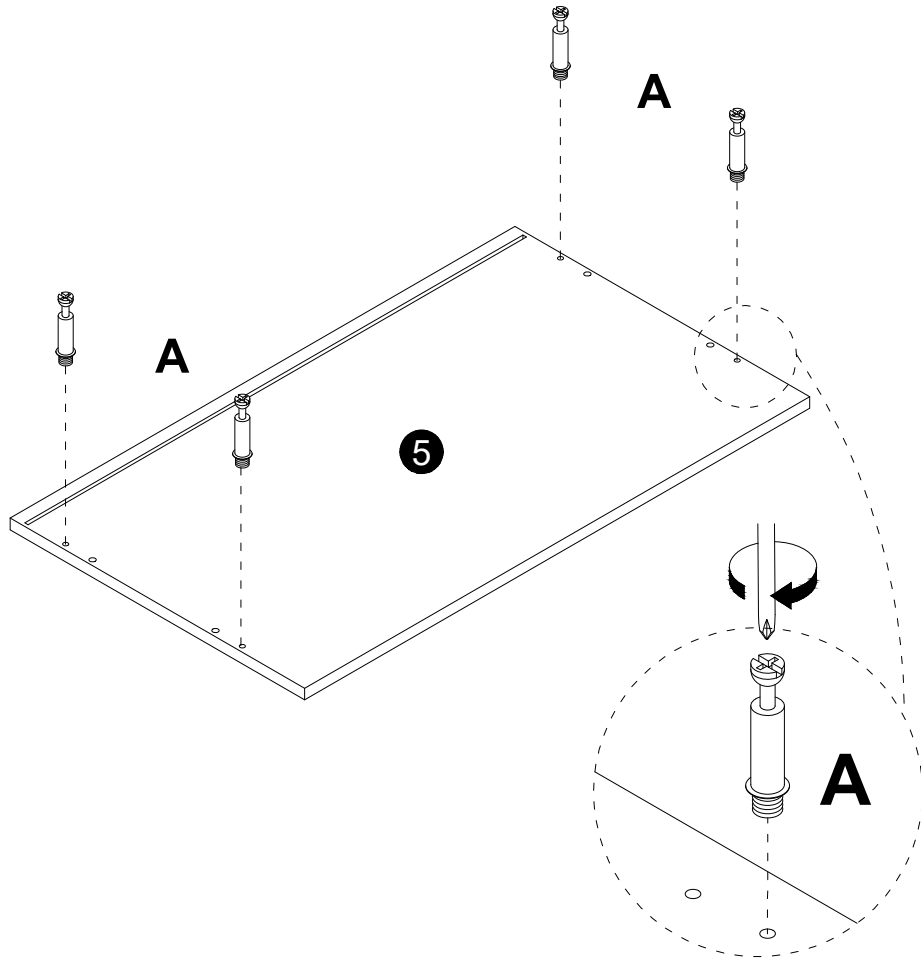
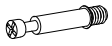

B x4

C x4



The backplate slots are rearward

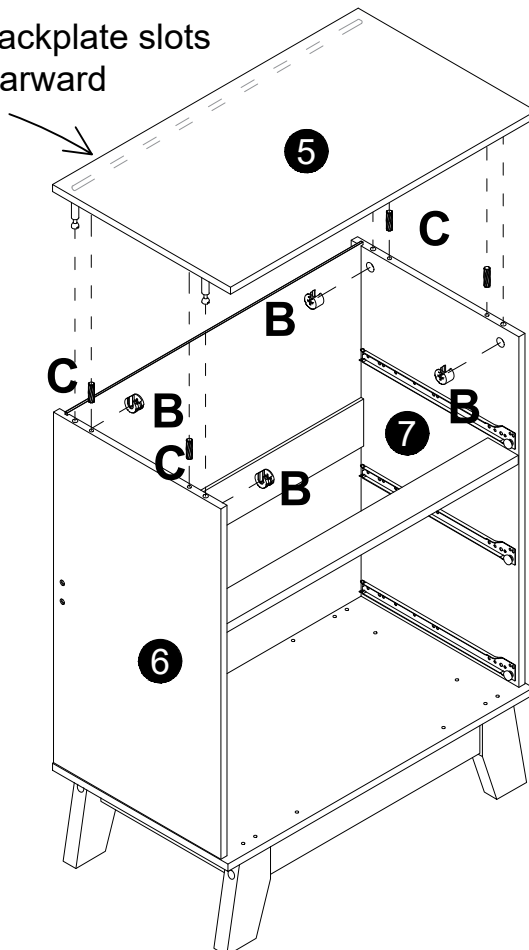

H x8

N x8

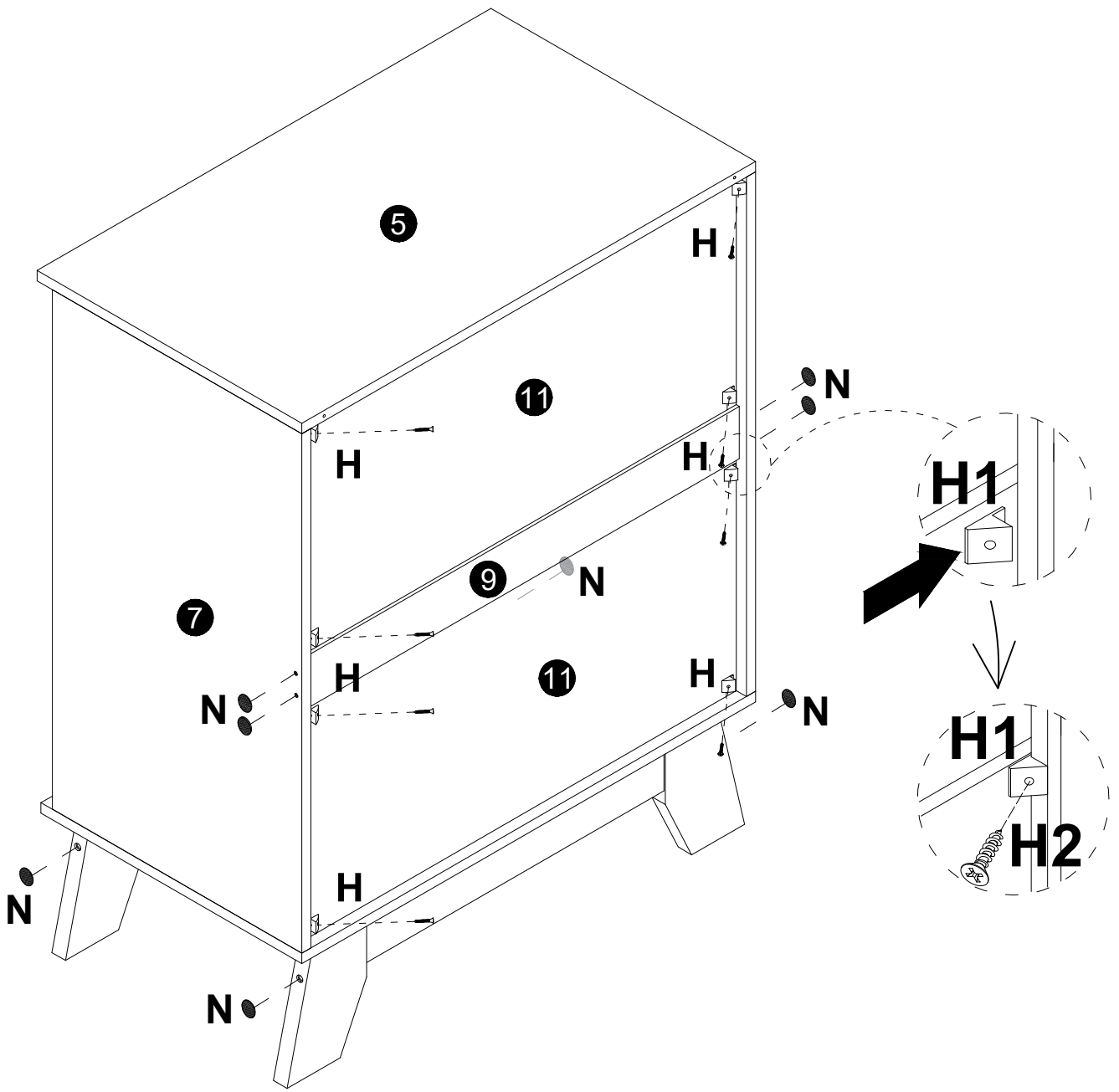
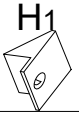

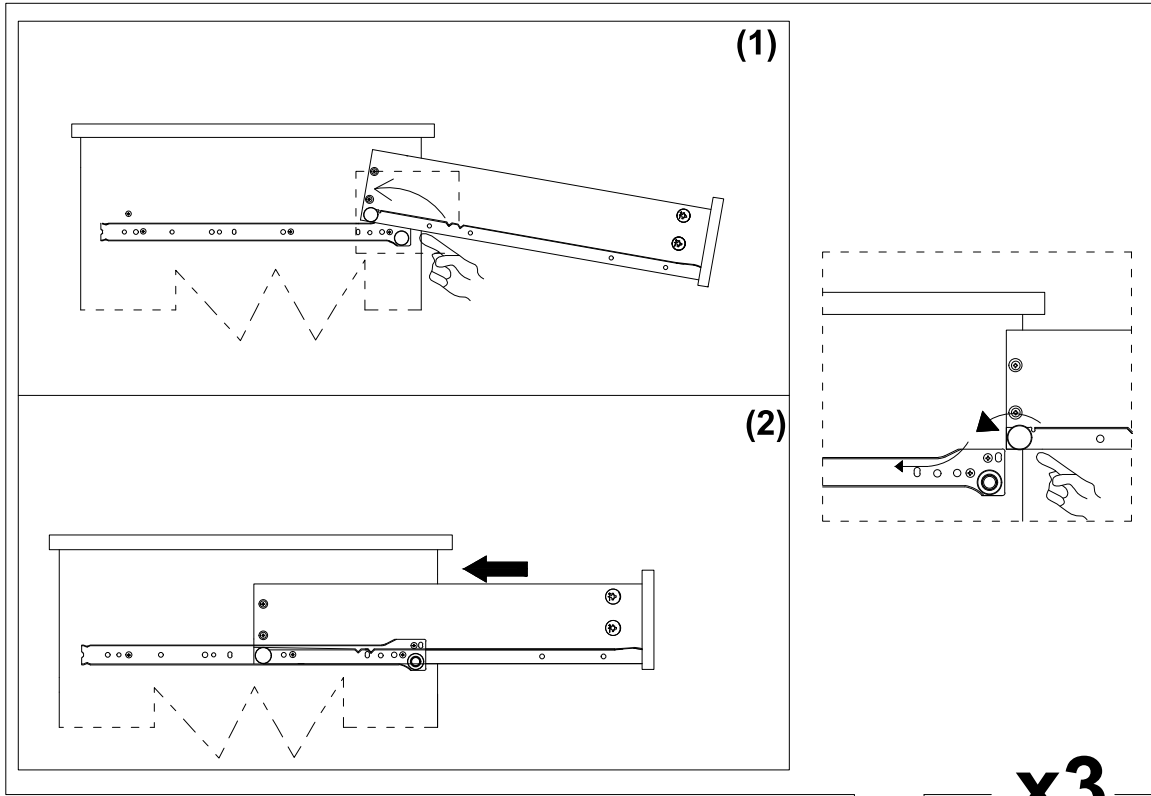

x3

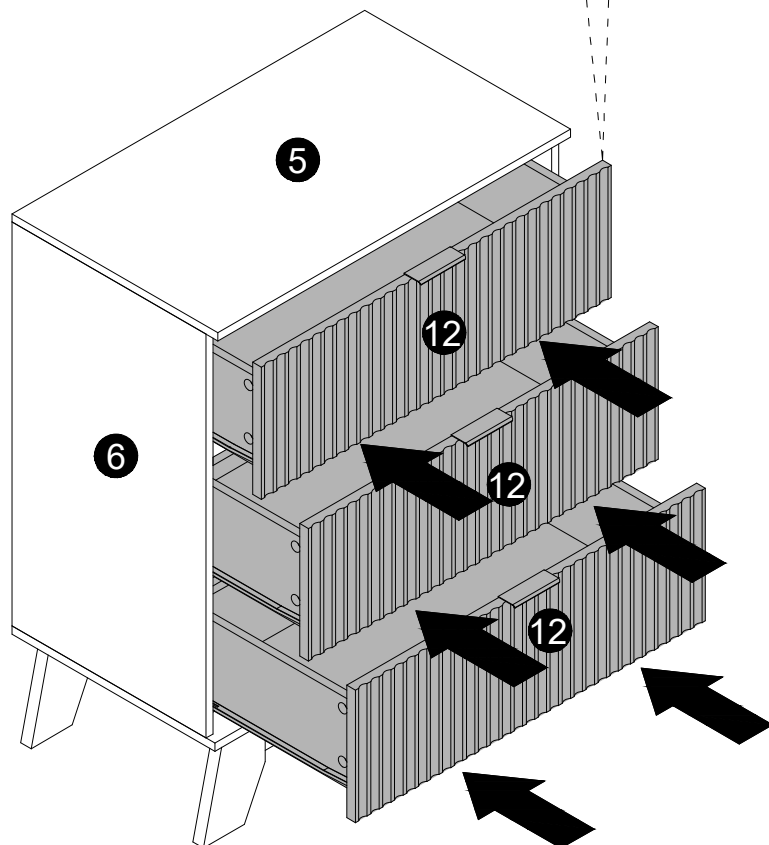

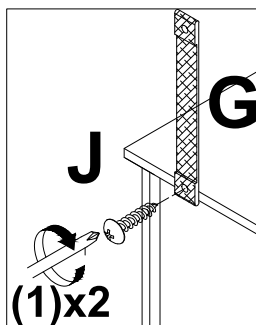
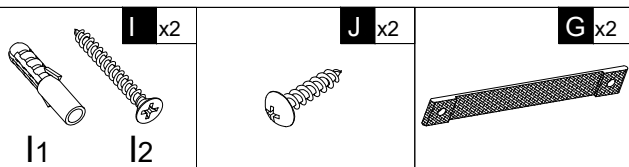

First fix the anti-rewind screw in the reserved hole of the product.

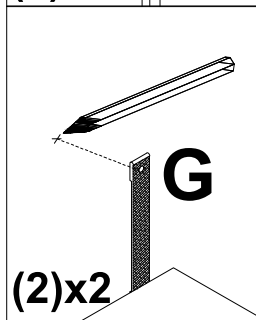

then, use a ruler to measure the approximate height of the product on the wall, and then mark it with a pen.

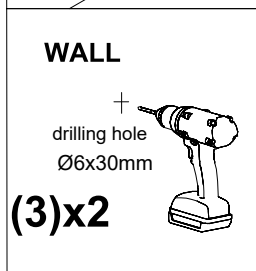

Then use a tape drill to make holes in the wall that are suitable for the product screws.

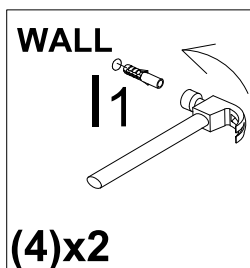

Then, put the expansion bolt into the hole

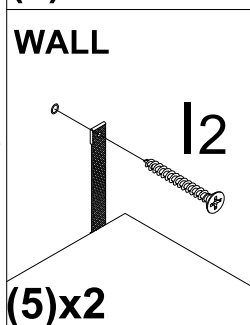

Finally, pass the matching screws through the "anti-rewind" and tighten them to fix them on the wall.

