



Manufactured by:
Backyard Discovery
3305 Airport Drive, Pittsburg, KS 66762
800-856-4445

Basepoint Business Centre: Rivermead Drive, Westlea, Swindon SN5 7EX Phone: 0800-118-2476
J.P. Coenstraat 7, The Bridge, The Hague, 2595 WP, Netherlands Phone: 08005678990

16x12 NORWOOD GAZEBO EU

MODEL # : 2306158



Please visit www.backyarddiscovery.com
For the most up to date assembly manual, to register your product, or to order replacement parts *Para obtener instrucciones en español, visite*
www.backyarddiscovery.com



EASY STEP-BY-STEP
3D INTERACTIVE INSTRUCTIONS
DOWNLOAD THE FREE APP



OWNER'S MANUAL - BASIC SETUP DIMENSIONS & ASSEMBLY NOTES

It is critically important that you start with square and level footings, concrete pad or deck to attach your structure

- Pay close attention to the items needed for each step. Make sure you are using the correct hardware for each step. Using incorrect hardware may result in improper assembly
- Remember to double check for underground utilities and overhead electrical lines

Post mounts are provided with your structure which allows you to permanently install your structure to a pre-existing or new wood or concrete surface. See Anchor Instructions for further details and recommendations.

- The hardware to attach the post mounts to the structure is included.
- The hardware to mount the structure permanently to a concrete surface is included.
- The hardware to mount the structure permanently to a wood deck is NOT included and will need to be purchased separately. You must ensure there is ample structural support under the deck before permanently attaching.

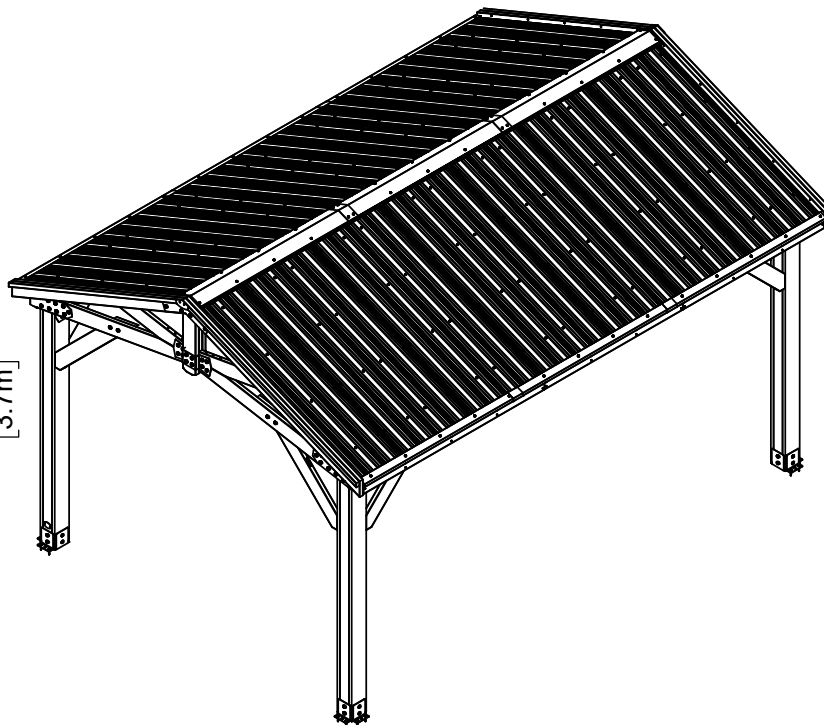
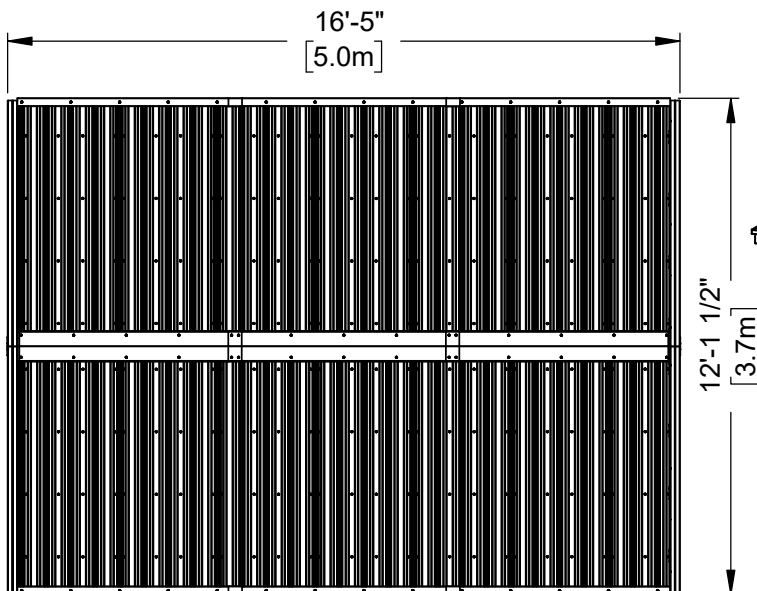
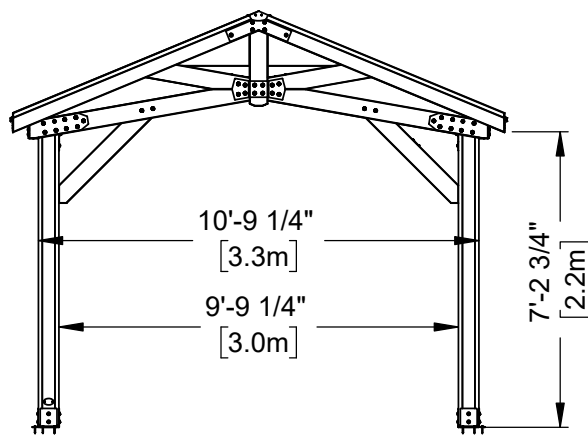
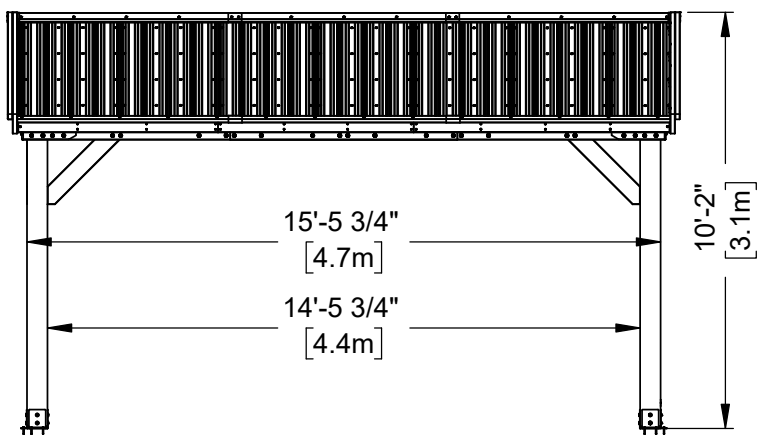

OWNER'S MANUAL - ANCHORING LAYOUT

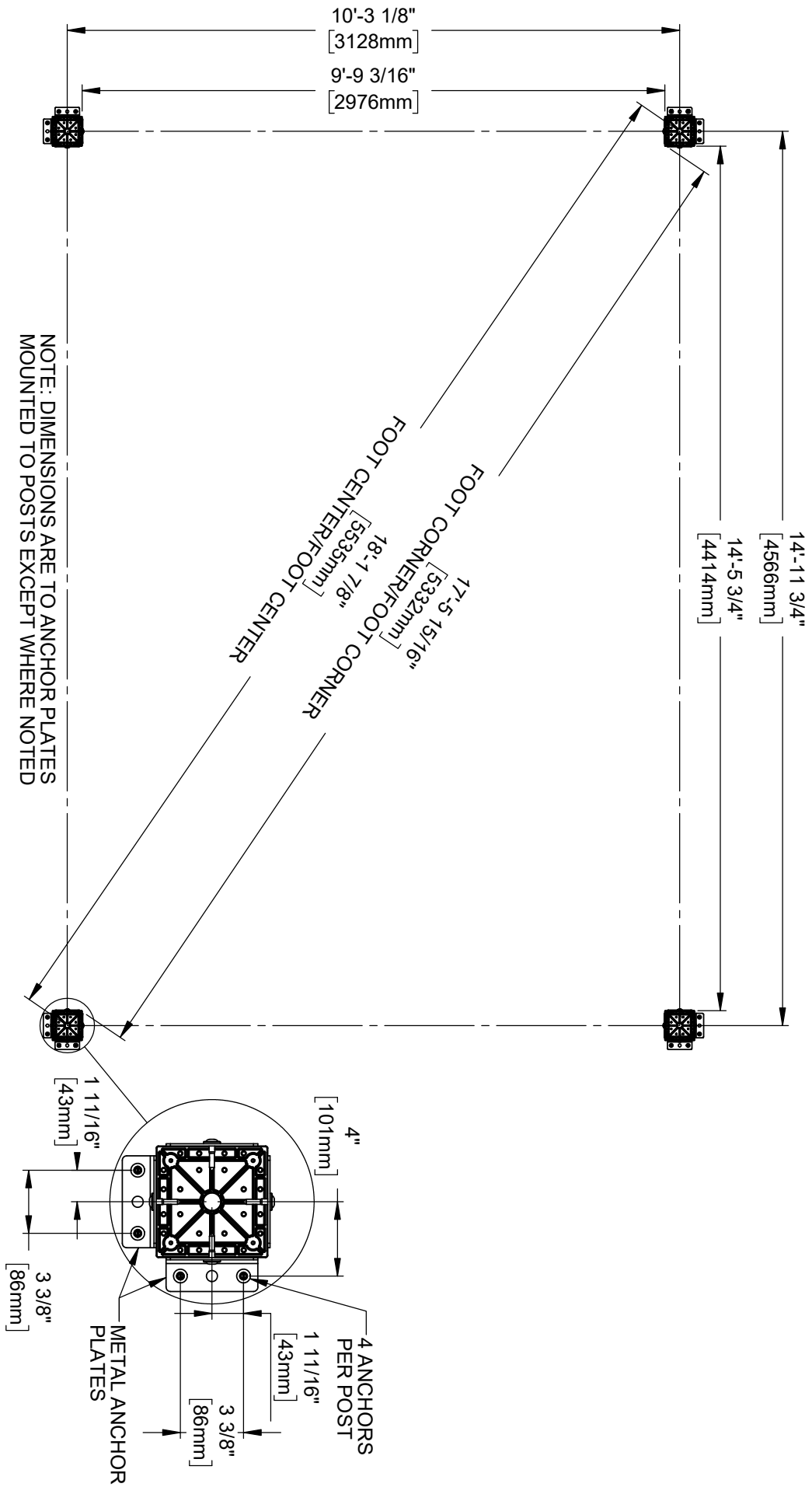

OWNER'S MANUAL - PARTS IDENTIFICATION

Wood Components (Not to Scale)

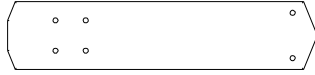

D01 | GABLE BOARD - W4L16850
(x4) | 1 3/8"x5 1/4"x24 1/4" (36x134x615)

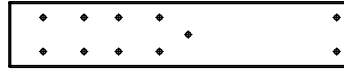

D02 | TOP RAIL - W4L16851
(x4) | 1 3/8"x5 1/4"x27 5/8" (36x134x703)

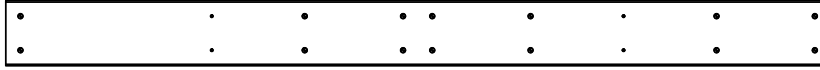

D03 | TOP RAIL - W4L16852
(x4) | 1 3/8"x5 1/4"x66 5/8" (36x134x1692)

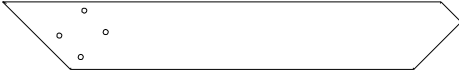

D04 | CORBEL - W4L16853
(x4) | 1 3/8"x5 1/4"x35 7/8" (36x134x910)



D05 | GABLE BOARD - W4L16854
(x2) | 1 3/8"x1 1/2"x5 1/4" (36x38x134)

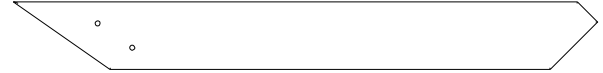

D06 | CORBEL - W4L16855
(x3) | 1 3/8"x5 1/4"x45 5/8" (36x134x1160)

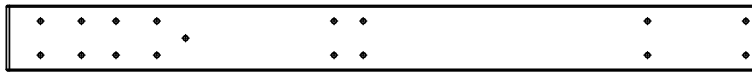

D07 | TOP RAIL - W4L16856
(x4) | 1 3/8"x5 1/4"x61" (36x134x1549)

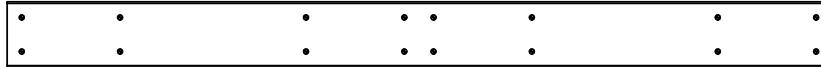

D08 | TOP RAIL - W4L16857
(x2) | 1 3/8"x5 1/4"x66 5/8" (36x134x1692)

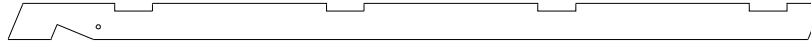

E01 | RAFTER - W4L16858
(x8) | 1 3/8"x3 3/8"x76 3/8" (36x86x1941)

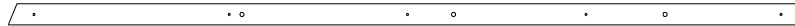

E02 | TRUSS - W4L16859
(x4) | 1 7/16"x1 15/16"x74 15/16" (36x50x1902)

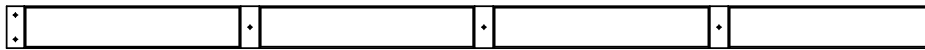

E03 | SHEATHING BOARD - W4L16860
(x8) | 1 3/8"x5 1/4"x75 1/8" (36x134x1907)



E04 | SHEATHING BOARD - W4L16861
(x8) | 1 3/8"x3 3/8"x57 3/8" (36x86x1458)



E05 | RAFTER - W4L16862
(x8) | 1 3/8"x3 3/8"x76 3/8" (36x86x1941)



E06 | ACCESSORY TRUSS - W4L16863
(x8) | 1 3/8"x3 3/8"x73 13/16" (36x86x1875)



E07 | SHEATHING BOARD - W4L16864
(x8) | 1 3/8"x3 3/8"x58 5/8" (36x86x1490)

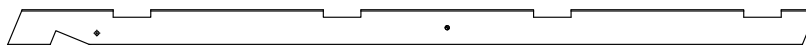

E08 | RAFTER - W4L16865
(x6) | 1 3/8"x3 3/8"x76 3/8" (36x86x1941)



G01 | COVER BOARD - W4L16917
(x2) | 1"x5 1/4"x89 1/2" (24x134x2274)

OWNER'S MANUAL - PARTS IDENTIFICATION

Wood Components (Not to Scale)



AD01 | RAFTER - W4L16866
(x2) | 1"x4"x74 3/4" (24x102x1900)



AD02 | RAFTER - W4L16867
(x2) | 1"x4"x66 3/8" (24x102x1686)



AD03 | RAFTER - W4L16868
(x2) | 1"x4"x41 5/8" (24x102x1057)



H01 | FASCIA - W4L16869
(x2) | 1"x3 3/8"x57 3/8" (24x86x1458)



H02 | FASCIA - W4L16870
(x2) | 1"x3 3/8"x58 5/8" (24x86x1490)



H03 | FASCIA - W4L16871
(x2) | 1"x3 3/8"x58 3/8" (24x86x1482)



H04 | FASCIA - W4L16872
(x1) | 1"x3 3/8"x57 3/8" (24x86x1458)



H05 | FASCIA - W4L16873
(x2) | 1"x3 3/8"x75 1/8" (24x86x1907)

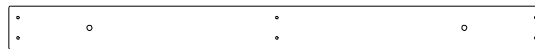

H06 | FASCIA - W4L16874
(x2) | 1"x3 3/8"x41 7/8" (24x86x1064)



H07 | FASCIA - W4L16875
(x1) | 1"x3 3/8"x57 3/8" (24x86x1458)



H08 | NOTCHED SUPPORT BOARD - W4L16915
(x2) | 1"x3 3/8"x89 1/2" (24x86x2274)



J09 | RIDGE CAP STIFFENER - W4L16876
(x4) | 1"x2 3/8"x53 7/8" (24x60x1367)

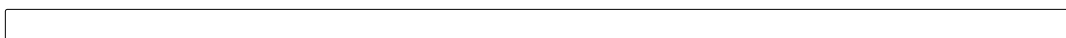

J10 | RIDGE CAP STIFFENER - W4L16877
(x2) | 1"x2 3/8"x83 1/2" (24x60x2121)

OWNER'S MANUAL - PARTS IDENTIFICATION

Wood Components (Not to Scale)



P01 | POST - W2A03501
(x2) | 6"x6"x89 1/2" (152x152x2274)



P02 | POST - W2A03502
(x2) | 6"x6"x89 1/2" (152x152x2274)



GP1 | GABLE PANEL - W2A03499
(x2) | 2 13/16"x5 1/4"x80 3/16" (72x134x2037)

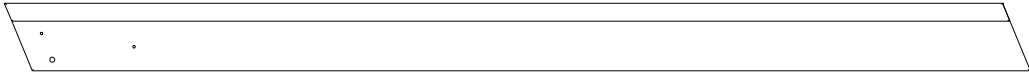

GP2 | GABLE PANEL - W2A03500
(x2) | 2 13/16"x5 1/4"x80 3/16" (72x134x2037)



CA01 | CORBEL - W2A03504
(x1) | 1 7/16"x5 3/8"x46 1/16" (36x136x1160)

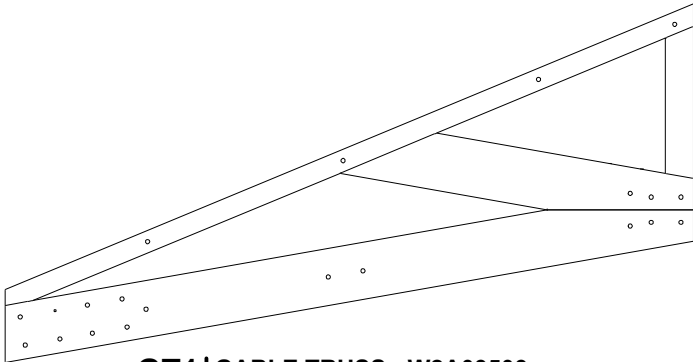

GT1 | GABLE TRUSS - W2A03503
(x4) | 1 7/16"x33 5/8"x64 9/16" (36x854x1640)

OWNER'S MANUAL - PARTS IDENTIFICATION

Hardware Components

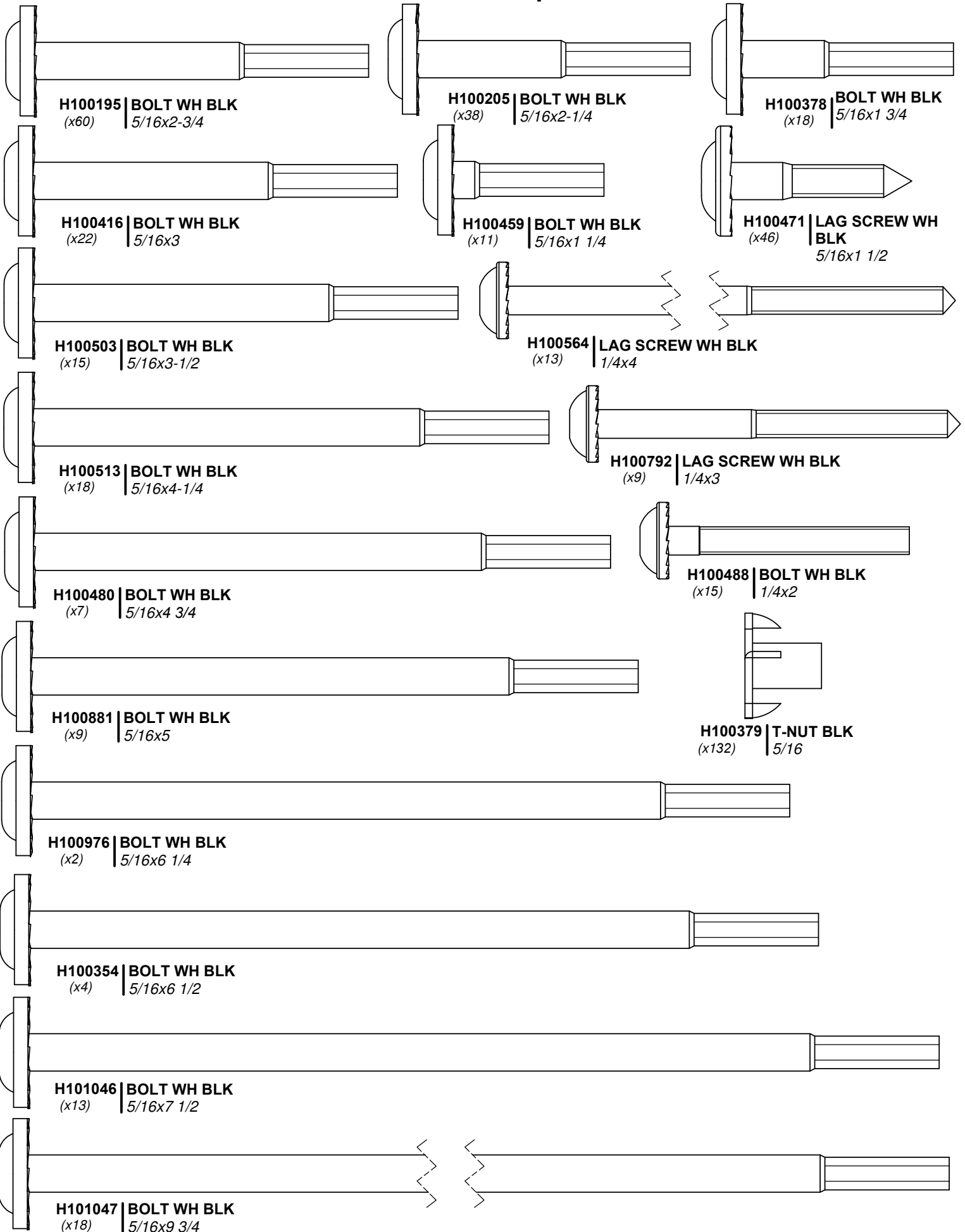

OWNER'S MANUAL - PARTS IDENTIFICATION

Hardware Components

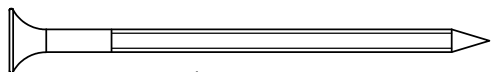

H100201 | SCREW PFH BLK
(64) | 8x2-1/2

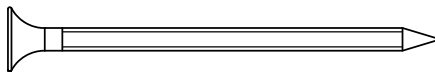

H100483 | SCREW PFH BLK
(x4) | 8x2 1/4

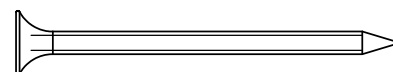

H100391 | SCREW PFH BLK
(x216) | 8x2

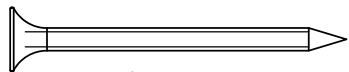

H100200 | SCREW PFH BLK
(x24) | 8x1 1/2

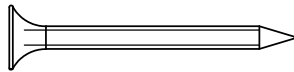

H100382 | SCREW PFH BLK
(x9) | 8x1 3/4

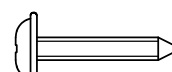

H100392 | SCREW PWH BLK
(x28) | 8x3/4

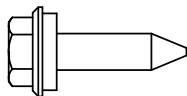

H100833 | SCREW WOODGRIP
(x250) | 10x3/4

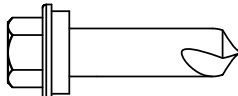

H100759 | SCREW TAPPING
(x30) | 1/4x3/4

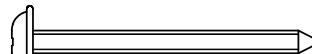

H100823 | SCREW PWH BLK
(x30) | 8x1-1/2

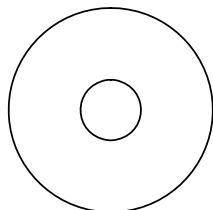

H100478 | WASHER FLAT BLK
(96) | 8x27

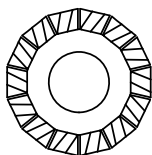

H100198 | WASHER LOCK EXT BLK
(x124) | 8x19

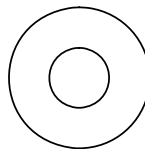

H100630 | WASHER FLAT BLK
(x33) | 8x19

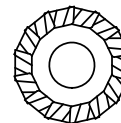

H100405 | WASHER LOCK EXT BLK
(x22) | 6x15

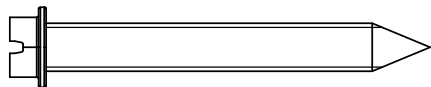

H100120 | SCREW CONCRETE ANCHOR
(x18) | 1/4x2

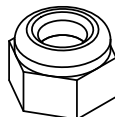

H100479 | NUT LOCK BLK
(x90) | 5/16



H100653 | NUT LOCK BLK
(x15) | 1/4

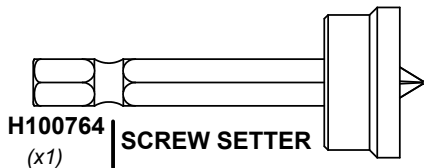

H100764 | SCREW SETTER
(x1)

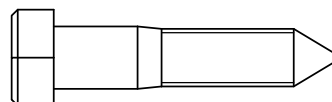

H100659 | LAG SCREW BLK
(x4) | 5/16x1 1/2

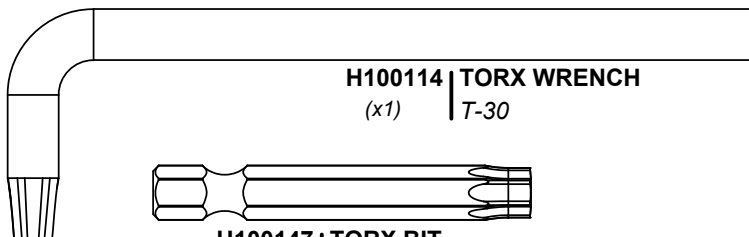

H100114 | TORX WRENCH
(x1) | T-30

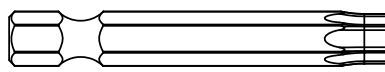

H100147 | TORX BIT
(x1) | T-30



H101106 | HEX DRIVER
(x1) | 5/16



H101100 | MAGNETIC DRIVER
(x1)

OWNER'S MANUAL - PARTS IDENTIFICATION

Accessory Components (Not to Scale)

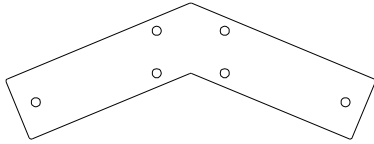

A4M01130 | GABLE BRACKET
(x2)

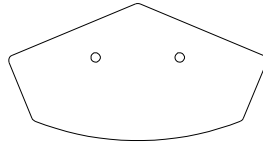

A4M01147 | PEAK SEAM BRACKET
(x2)

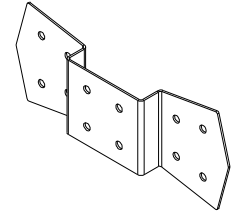

A4M01129 | GABLE BRACKET
(x4)

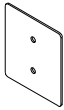

A4M00978 | POST PLATE
(x8)

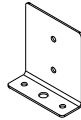

A4M00977 | POST ANCHORING PLATE
(x8)

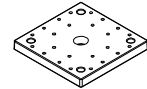

A6P00308 | 6x6 POST FOOT
(x4)

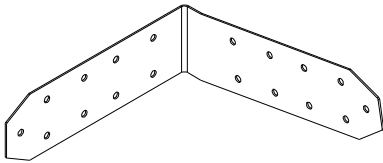

A4M01301 | RIGHT OUTSIDE BRACKET
(x2)

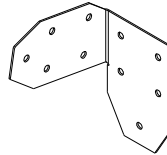

A4M01232 | LEFT ANGLE BRACKET
(x2)

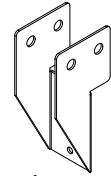

A4M01752 | RAFTER CLIP
(x14)

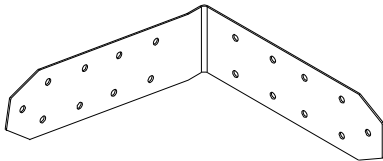

A4M01302 | LEFT OUTSIDE BRACKET
(x2)

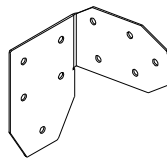

A4M01233 | RIGHT ANGLE BRACKET
(x2)

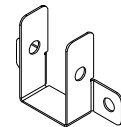

A4M01148 | TRUSS BRACKET
(x2)



A100241 | BYD ID TAG
(SMALL)
WITHOUT AGES
(x1)

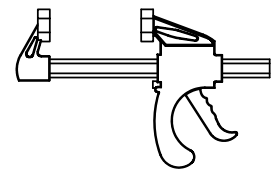

A6P00460 | 6" QUICK RELEASE
BAR CLAMP
(x2)

OWNER'S MANUAL - PARTS IDENTIFICATION

Accessory Components (Not to Scale)

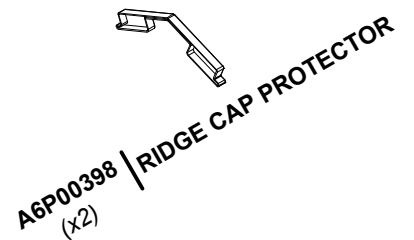
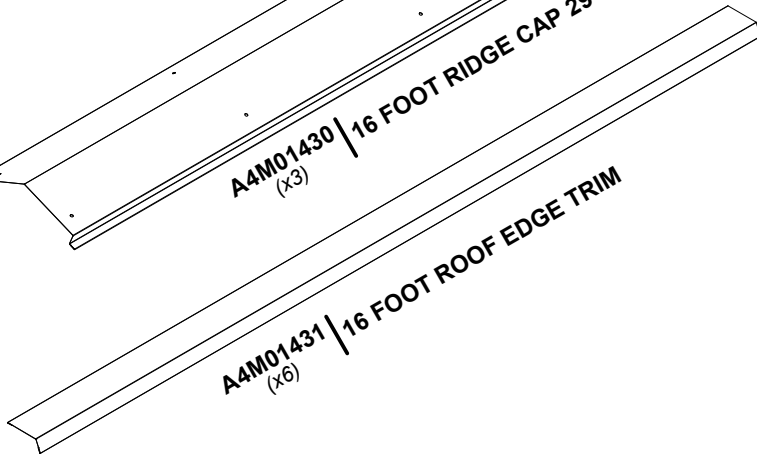
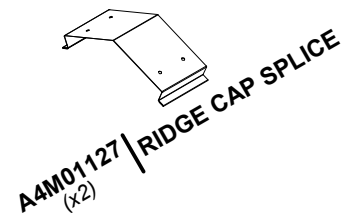
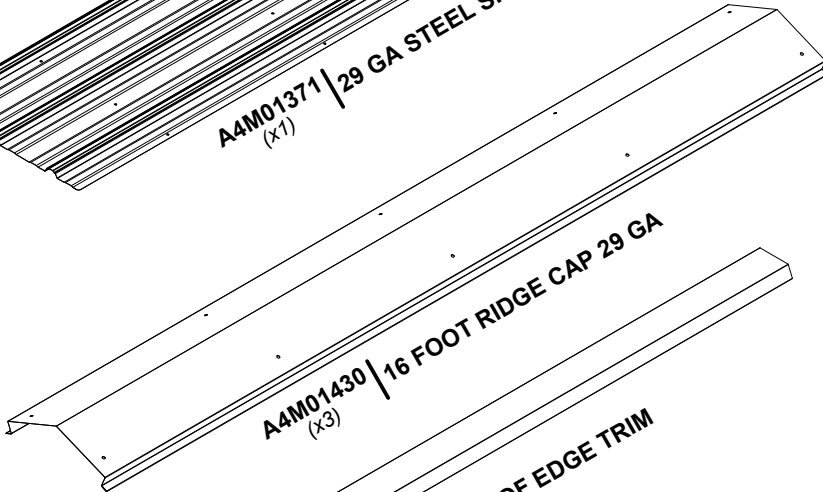
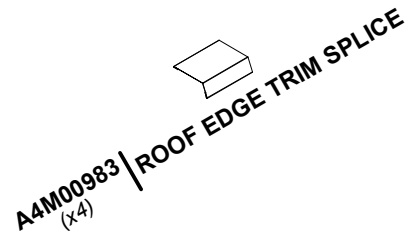
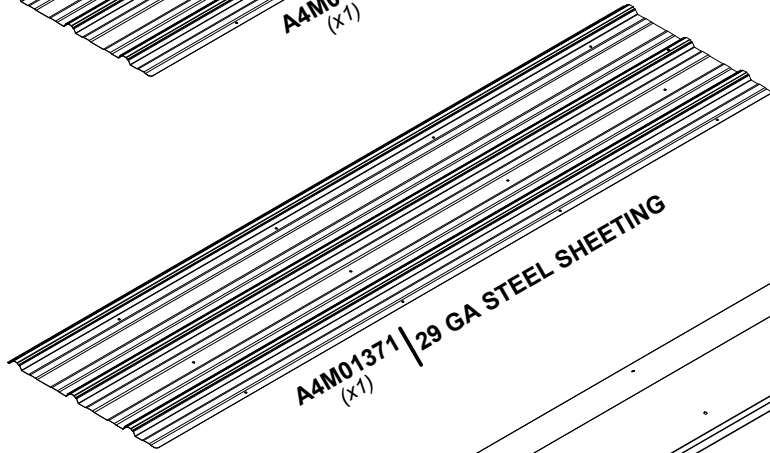
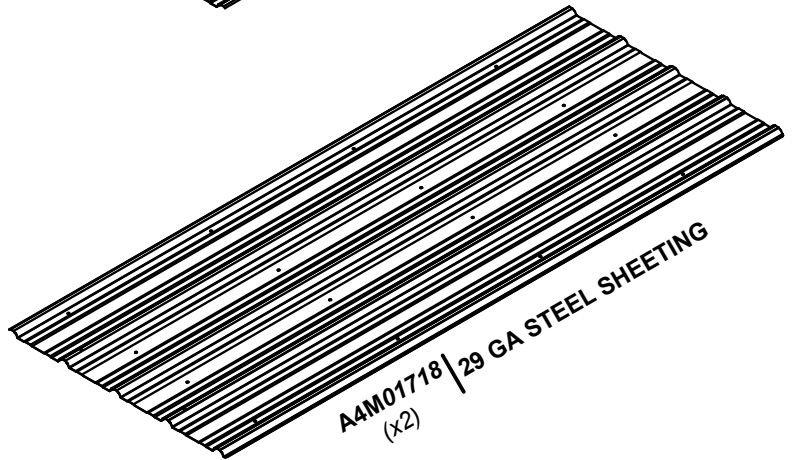
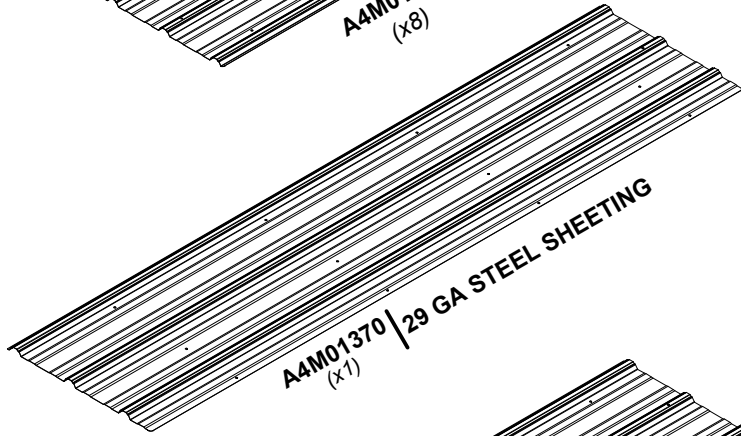
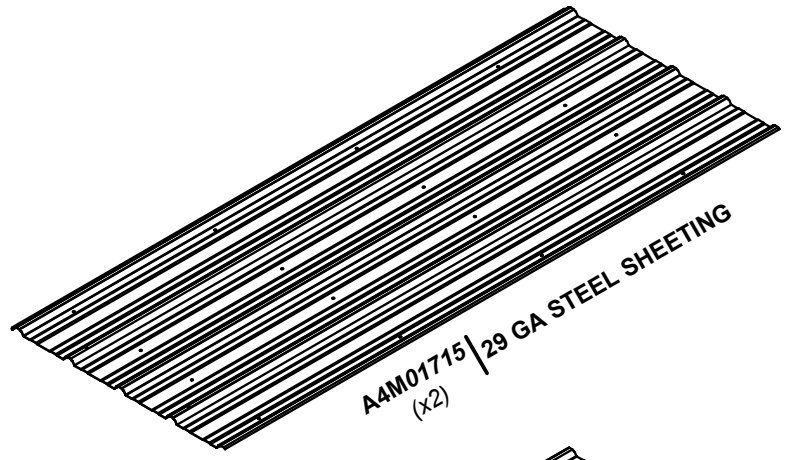
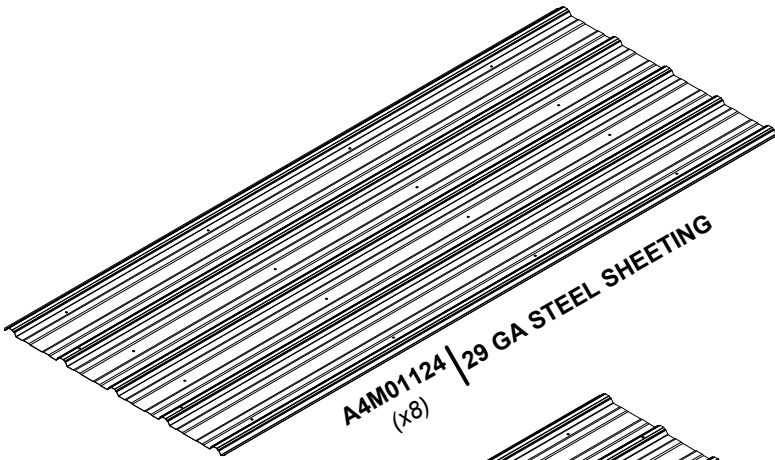

PRE-ASSEMBLY STEP 1 - SORTING PARTS

It is critical for ease of assembly that you take the time to sort and organize the wood and hardware.

WOOD PARTS:

- Organize wood parts by the three-digit, alpha-numeric number stamped on each board (ex. P01).
- If there are multiple boards with the same stamped number, stack those pieces together.
- Stamps can be found on the flat surface of the boards or on the end of the boards.
- Allow yourself plenty of room - the wood pieces can take up a significant amount of space.

NOTE: CARTONS ARE NOT ORGANIZED BY BOARD NUMBER.



HARDWARE PARTS:

- We recommend that you have a separate table to organize the hardware.
- Hardware bags are printed with a seven-digit, alpha-numeric part number.
- You can organize your hardware by part number or group by hardware type (i.e. bolts, nuts, etc.).
- During assembly you only need to reference the last four digits of the number.

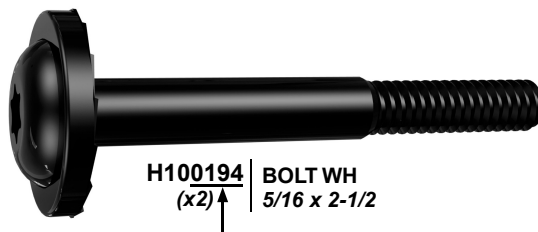

H100194 | BOLT WH
(x2) ↑ 5/16 x 2-1/2

PRE-ASSEMBLY STEP 2 - TOOLS REQUIRED



Cordless Drill or
Electric Drill



Drill Attachments:
Phillips Head



1/8", 3/16", 3/8" &
7/16" Drill Bits



Phillips Screw Driver

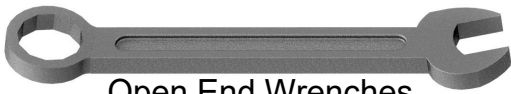

Open End Wrenches
1/2" & 9/16"



3/8" Drive Ratchet, 1/2" &
7/16" STD Sockets 1/2" & 7/16"
Deep Sockets



Claw Hammer



Rubber Mallet -
Optional

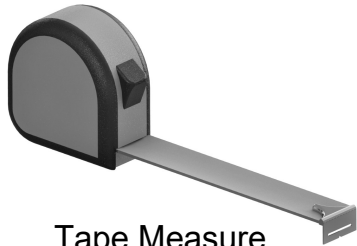

Tape Measure

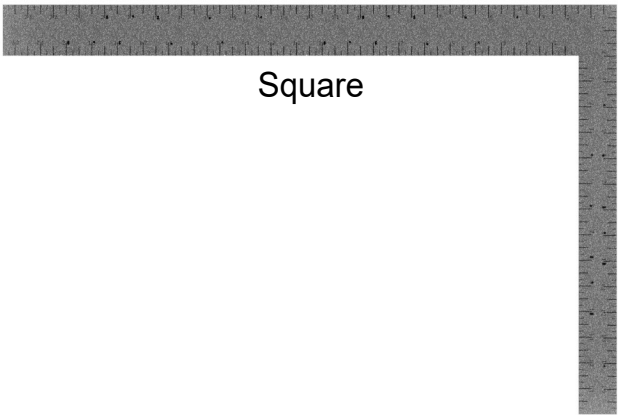

Square



Level 24"

PRE-ASSEMBLY STEP 3 - CHOOSE YOUR ASSEMBLY METHOD

There are several types of assembly instructions available to you.

1. Printed Assembly Manual included with your set
2. BILT APP - 3D interactive instructions
3. Combination of the Printed Manual and BILT APP (Note: Step numbers can differ between the two methods)



The graphic features the BILT logo (a hexagon with a white dot inside) and the word "BILT." in a bold, sans-serif font. To the right is a large QR code. Below the logo, the text "Scan for easy 3D instructions" is written in a large, bold font. Underneath this, it says "Download the BILT app before you begin". To the right of the text are two buttons: "Download on the App Store" and "GET IT ON Google Play". At the bottom, a smartphone screen displays a 3D assembly instruction for step 17, showing a metal frame with a horizontal bar and several hanging components. The screen includes a "Hardware Needed" label, a close button (X), a menu button (three dots), a volume icon, and navigation arrows.

STEP 4 - POST ASSEMBLY

| QTY | PART NUMBER | DESCRIPTION |
|-----|-------------|-------------------------|
| 8 | H100200 | SCREW PFH 8 X 1 1/2 BLK |

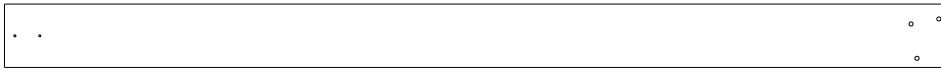

P01 | POST - W2A03501
(x1) | 6"x6"x89 1/2" (152x152x2274)

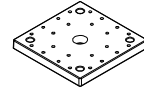

A6P00308 | 6x6 POST FOOT
(x2)

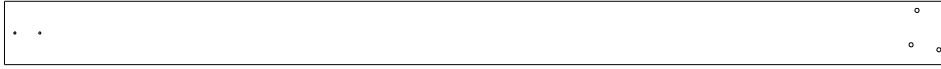

P02 | POST - W2A03502
(x1) | 6"x6"x89 1/2" (152x152x2274)

FOR EASE OF ASSEMBLY, WE RECOMMEND USING SAW HORSES FOR STEPS 4 - 11.

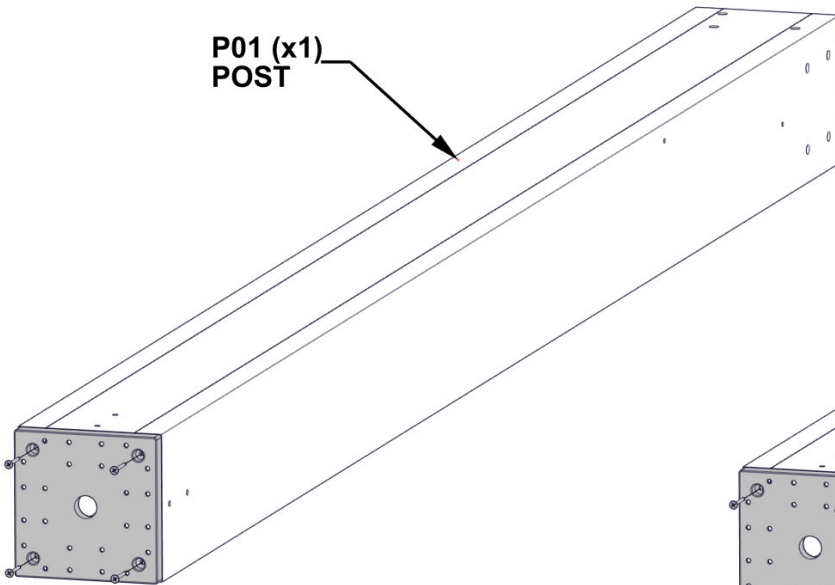

P01 (x1)
POST

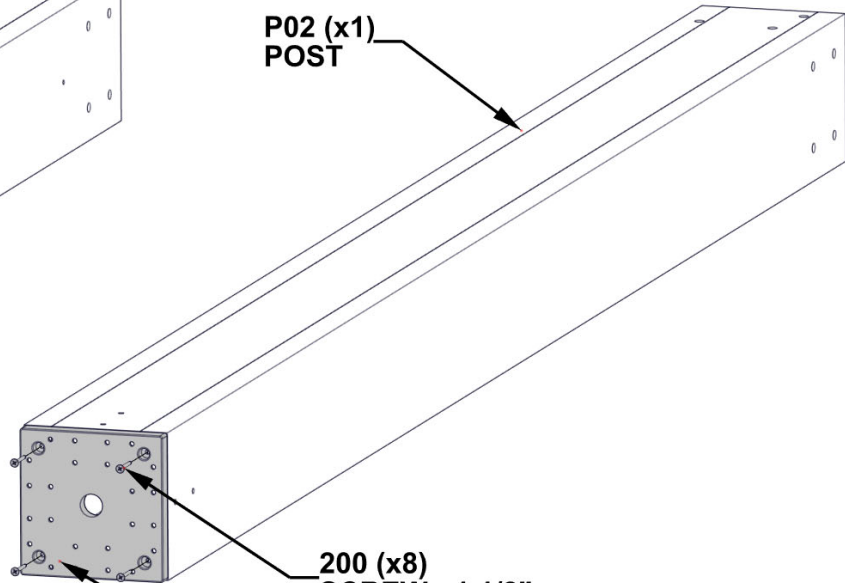

P02 (x1)
POST

200 (x8)
SCREW - 1 1/2"

308 (x2)
6x6 POST FOOT

ALIGN POST FOOT AND DRILL 1/8" PILOT HOLES FOR THE ATTACHMENT OF HARDWARE.

STEP 5 - GABLE ASSEMBLY

| QTY | PART NUMBER | DESCRIPTION |
|-----|-------------|-------------------------|
| 2 | H100483 | SCREW PFH 8 X 2 1/4 BLK |



D01 | GABLE BOARD - W4L16850
(x1) | 1 3/8"x5 1/4"x24 1/4" (36x134x615)



D05 | GABLE BOARD - W4L16854
(x1) | 1 3/8"x1 1/2"x5 1/4" (36x38x134)

ALIGN D05 WITH D01 ENSURING THAT BOTTOM FACES ARE FLUSH. DRILL 1/8" PILOT HOLES IN D01 USING D05 AS TEMPLATE.

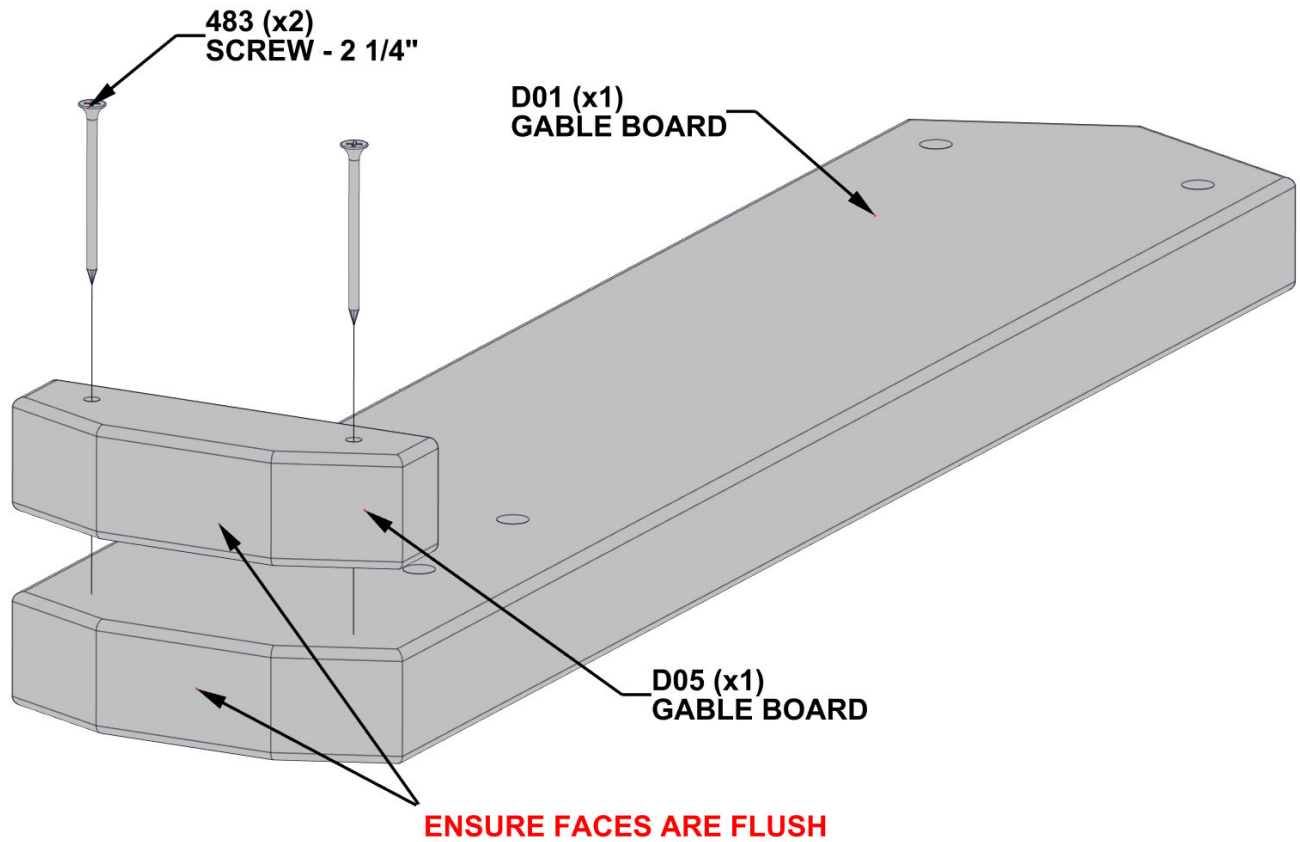

STEP 6 - GABLE ASSEMBLY

| QTY | PART NUMBER | DESCRIPTION |
|-----|-------------|----------------------|
| 4 | H100478 | WASHER FLAT 8X27 BLK |
| 4 | H100479 | NUT LOCK 5/16 BLK |
| 4 | H100881 | BOLT WH 5/16 X 5 BLK |

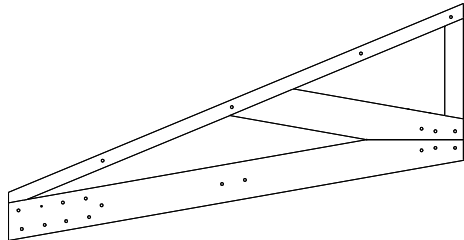

GT1 | GABLE TRUSS - W2A03503
(x2) 1 7/16"x33 5/8"x64 9/16" (36x854x1640)



D01 | GABLE BOARD - W4L16850
(x1) 1 3/8"x5 1/4"x24 1/4" (36x134x615)

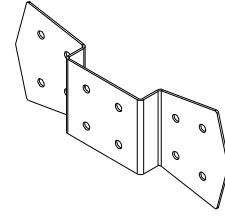

A4M01129 | GABLE BRACKET
(x2)

IF NEEDED FOR EASE OF ASSEMBLY, USE METAL BRACKET AS A GUIDE AND DRILL THROUGH USING A 7/16" - (10mm) DRILL BIT, THEN ASSEMBLE.

881 (x4) BOLT - 5"

TEMPORARILY ADD LONG BOLTS TO HELP ALIGN WOOD PARTS.

D01 (x1) GABLE BOARD

GT1 (x2) GABLE TRUSS

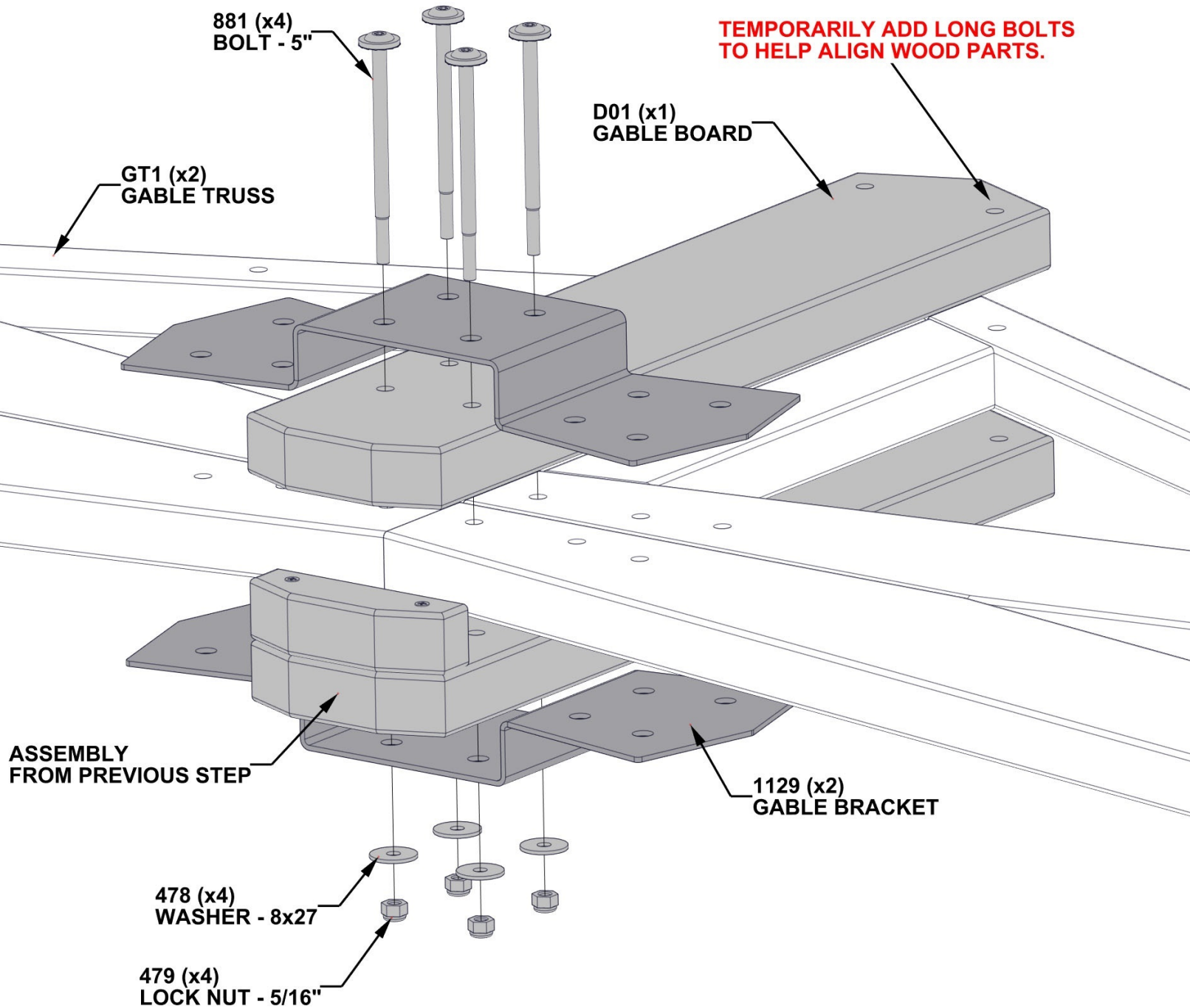

ASSEMBLY FROM PREVIOUS STEP

1129 (x2) GABLE BRACKET

478 (x4) WASHER - 8x27

479 (x4) LOCK NUT - 5/16"

STEP 7 - GABLE ASSEMBLY

| QTY | PART NUMBER | DESCRIPTION |
|-----|-------------|--------------------------|
| 8 | H100205 | BOLT WH 5/16 X 2 1/4 BLK |
| 8 | H100478 | WASHER FLAT 8X27 BLK |
| 8 | H100479 | NUT LOCK 5/16 BLK |

IF NEEDED FOR EASE OF ASSEMBLY, USE METAL BRACKET AS A GUIDE AND DRILL THROUGH USING A 7/16" - (10mm) DRILL BIT, THEN ASSEMBLE.

ENSURE THAT ALL BOLT HEADS ARE ON THE SAME SIDE.

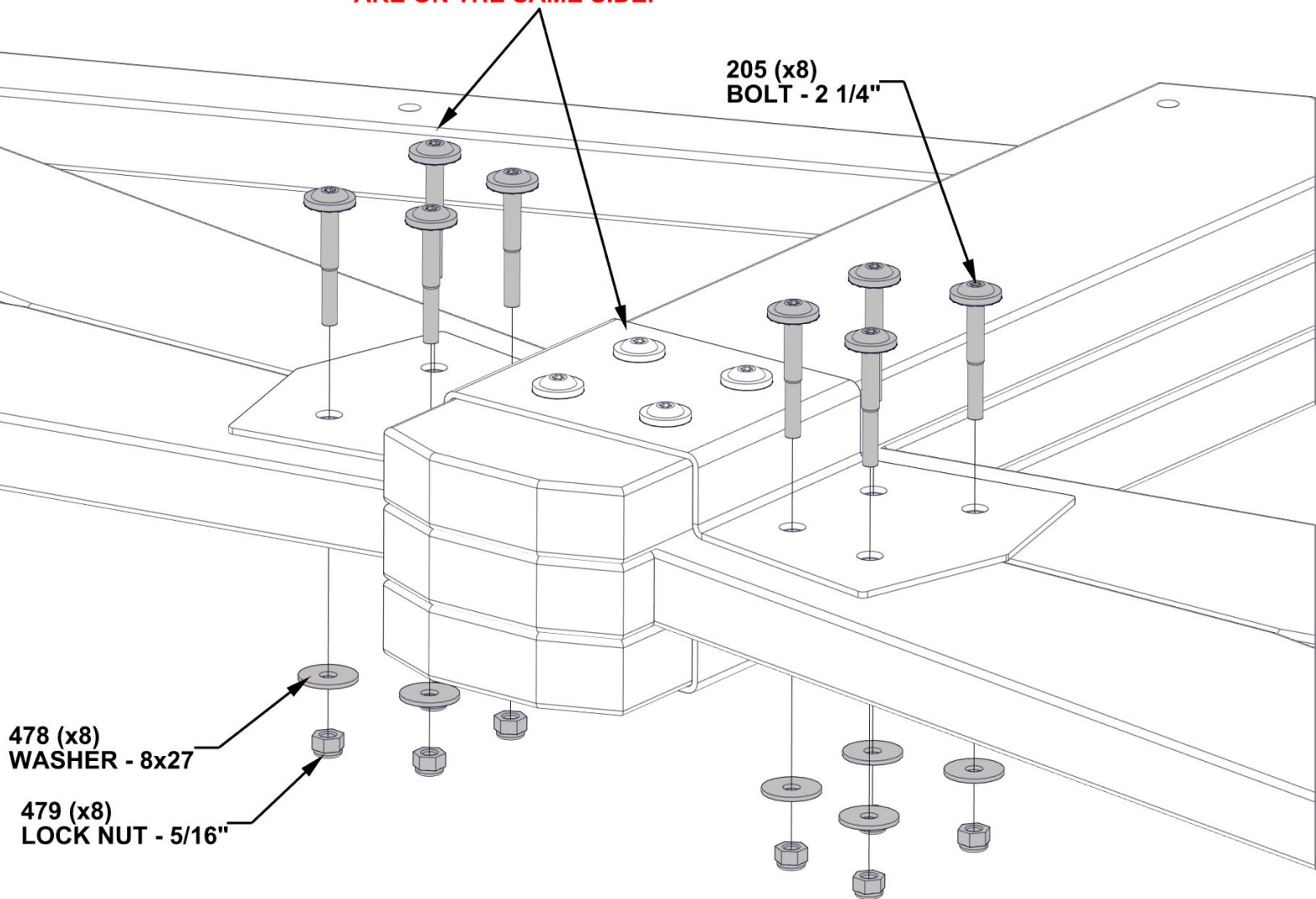

STEP 8A - GABLE ASSEMBLY

P01 | POST - W2A03501
(x1) | 6"x6"x89 1/2" (152x152x2274)

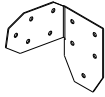

A4M01232 | LEFT ANGLE BRACKET
(x1)

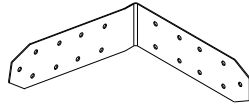

D02 | TOP RAIL - W4L16851
(x1) | 1 3/8"x5 1/4"x27 5/8" (36x134x703)

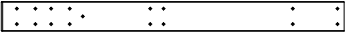

D07 | TOP RAIL - W4L16856
(x1) | 1 3/8"x5 1/4"x61" (36x134x1549)

A4M01302 | LEFT OUTSIDE BRACKET
(x1)

| QTY | PART NUMBER | DESCRIPTION |
|-----|-------------|-------------------------------|
| 5 | H100205 | BOLT WH 5/16 X 2 1/4 BLK |
| 8 | H100379 | T-NUT 5/16 BLK |
| 5 | H100416 | BOLT WH 5/16 X 3 BLK |
| 1 | H100471 | LAG SCREW WH 5/16 X 1 1/2 BLK |
| 10 | H100478 | WASHER FLAT 8X27 BLK |
| 9 | H100479 | NUT LOCK 5/16 BLK |
| 1 | H100659 | LAG SCREW HEX 5/16x1 1/2 BLK |
| 3 | H101046 | BOLT WH 5/16 X 7 1/2 BLK |
| 4 | H101047 | BOLT WH 5/16 X 9 3/4 BLK |

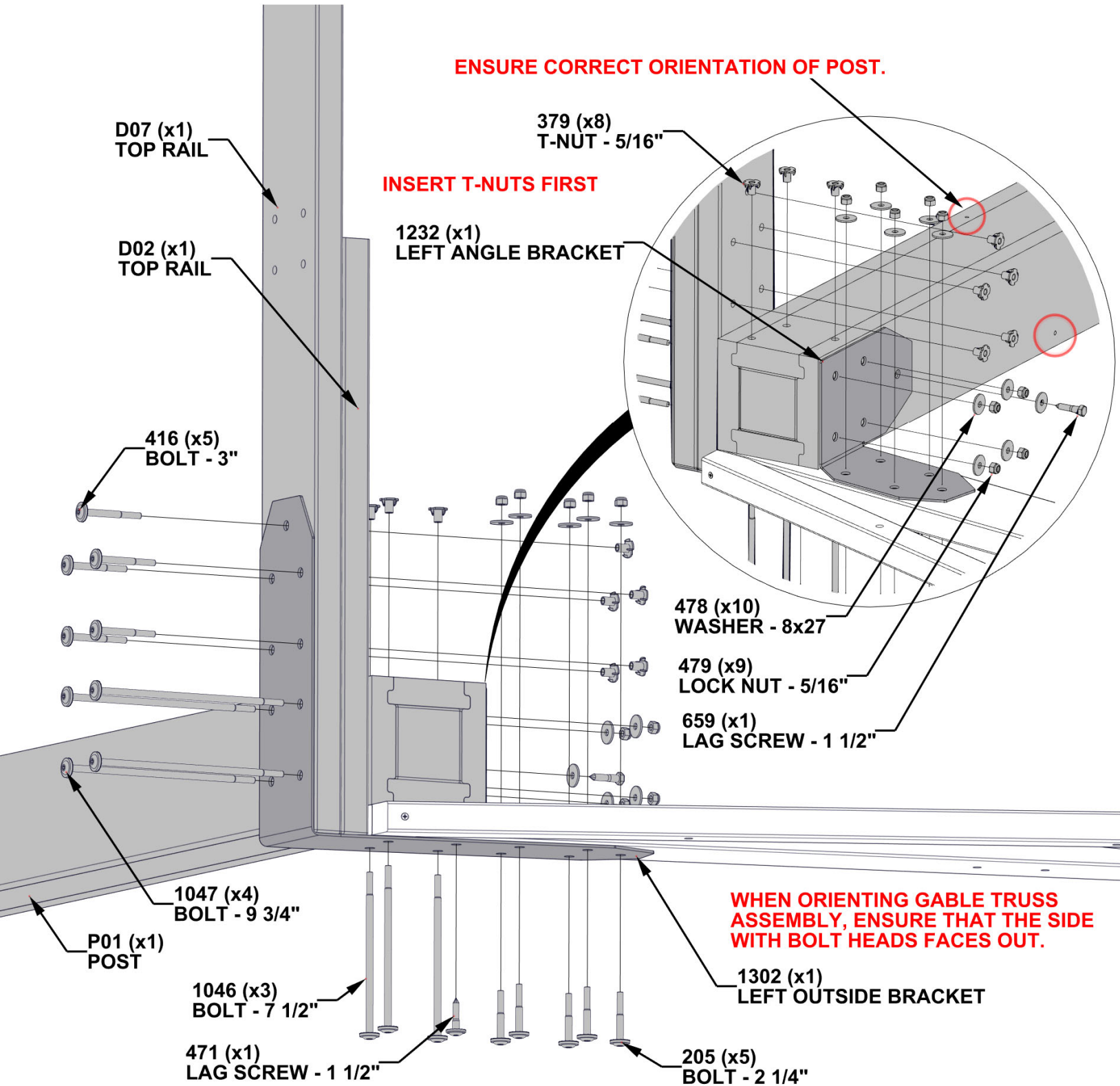

STEP 8B - GABLE ASSEMBLY

| QTY | PART NUMBER | DESCRIPTION |
|-----|-------------|-------------------------------|
| 5 | H100205 | BOLT WH 5/16 X 2 1/4 BLK |
| 8 | H100379 | T-NUT 5/16 BLK |
| 5 | H100416 | BOLT WH 5/16 X 3 BLK |
| 1 | H100471 | LAG SCREW WH 5/16 X 1 1/2 BLK |
| 10 | H100478 | WASHER FLAT 8X27 BLK |
| 9 | H100479 | NUT LOCK 5/16 BLK |
| 1 | H100659 | LAG SCREW HEX 5/16x1 1/2 BLK |
| 3 | H101046 | BOLT WH 5/16 X 7 1/2 BLK |
| 4 | H101047 | BOLT WH 5/16 X 9 3/4 BLK |

P02 | POST - W2A03502
(x1) | 6"x6"x89 1/2" (152x152x2274)

D02 | TOP RAIL - W4L16851
(x1) | 1 3/8"x5 1/4"x27 5/8" (36x134x703)

D07 | TOP RAIL - W4L16856
(x1) | 1 3/8"x5 1/4"x61" (36x134x1549)

A4M01233 | RIGHT ANGLE BRACKET
(x1)

A4M01301 | RIGHT OUTSIDE BRACKET
(x1)

ENSURE CORRECT ORIENTATION OF POST.

INSERT T-NUTS FIRST

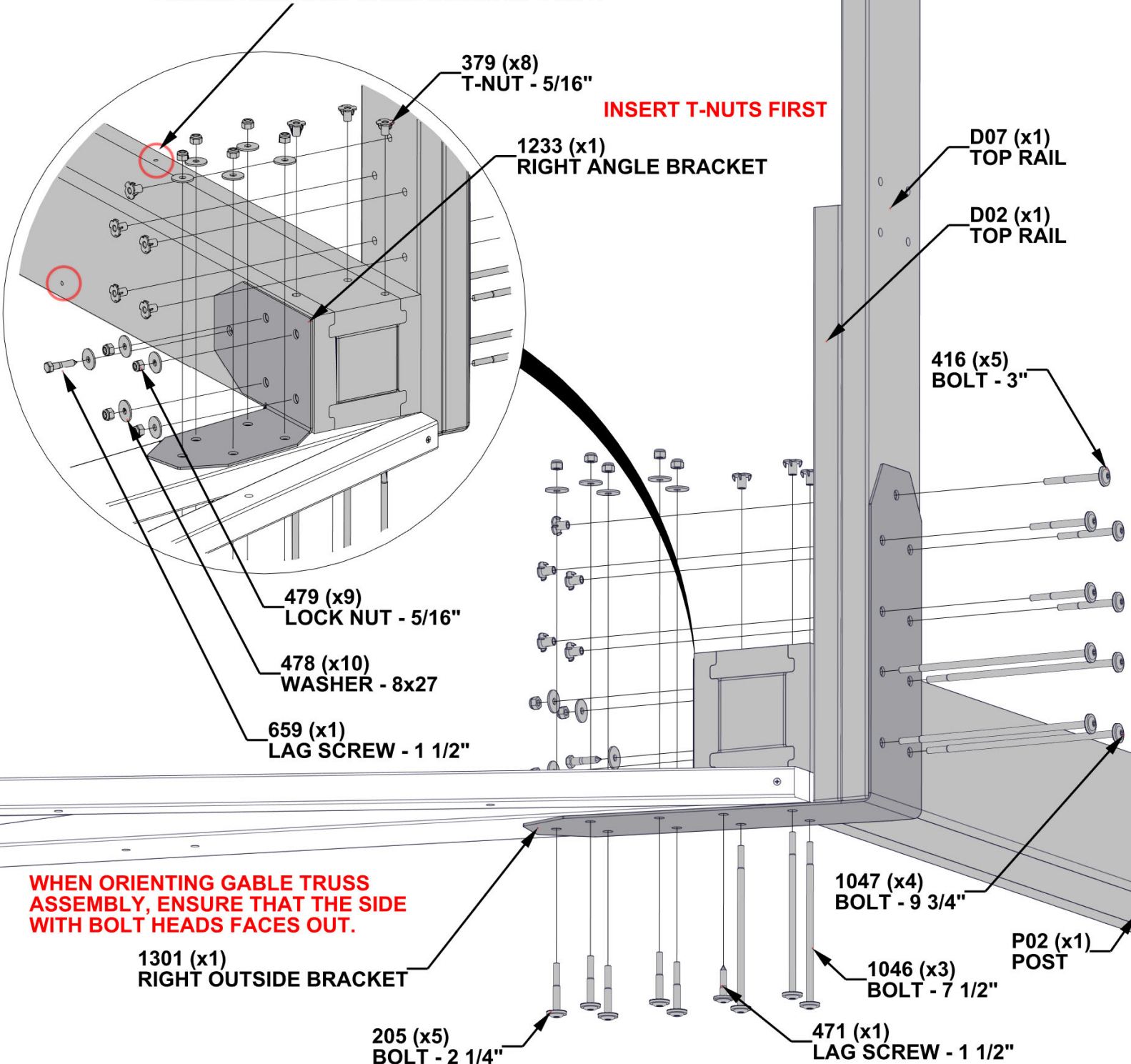

WHEN ORIENTING GABLE TRUSS ASSEMBLY, ENSURE THAT THE SIDE WITH BOLT HEADS FACES OUT.

1301 (x1) RIGHT OUTSIDE BRACKET

205 (x5) BOLT - 2 1/4"

1047 (x4) BOLT - 9 3/4"

1046 (x3) BOLT - 7 1/2"

471 (x1) LAG SCREW - 1 1/2"

P02 (x1) POST

STEP 9 - GABLE ASSEMBLY

| QTY | PART NUMBER | DESCRIPTION |
|-----|-------------|--------------------------|
| 4 | H100195 | BOLT WH 5/16 X 2 3/4 BLK |
| 4 | H100198 | WASHER LOCK EXT 8X19 BLK |
| 4 | H100379 | T-NUT 5/16 BLK |
| 2 | H100405 | WASHER LOCK EXT 6X15 BLK |
| 2 | H100792 | LAG SCREW WH 1/4 X 3 BLK |

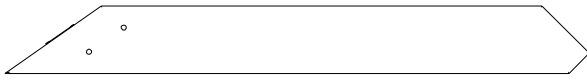

CA01 | CORBEL - W2A03504
(x1) | 1 7/16"x5 3/8"x46 1/16" (36x136x1160)



D06 | CORBEL - W4L16855
(x3) | 1 3/8"x5 1/4"x45 5/8" (36x134x1160)

TWO D06 BOARDS WILL BE USED FOR OTHER END GABLE.

INSERT T-NUTS FIRST

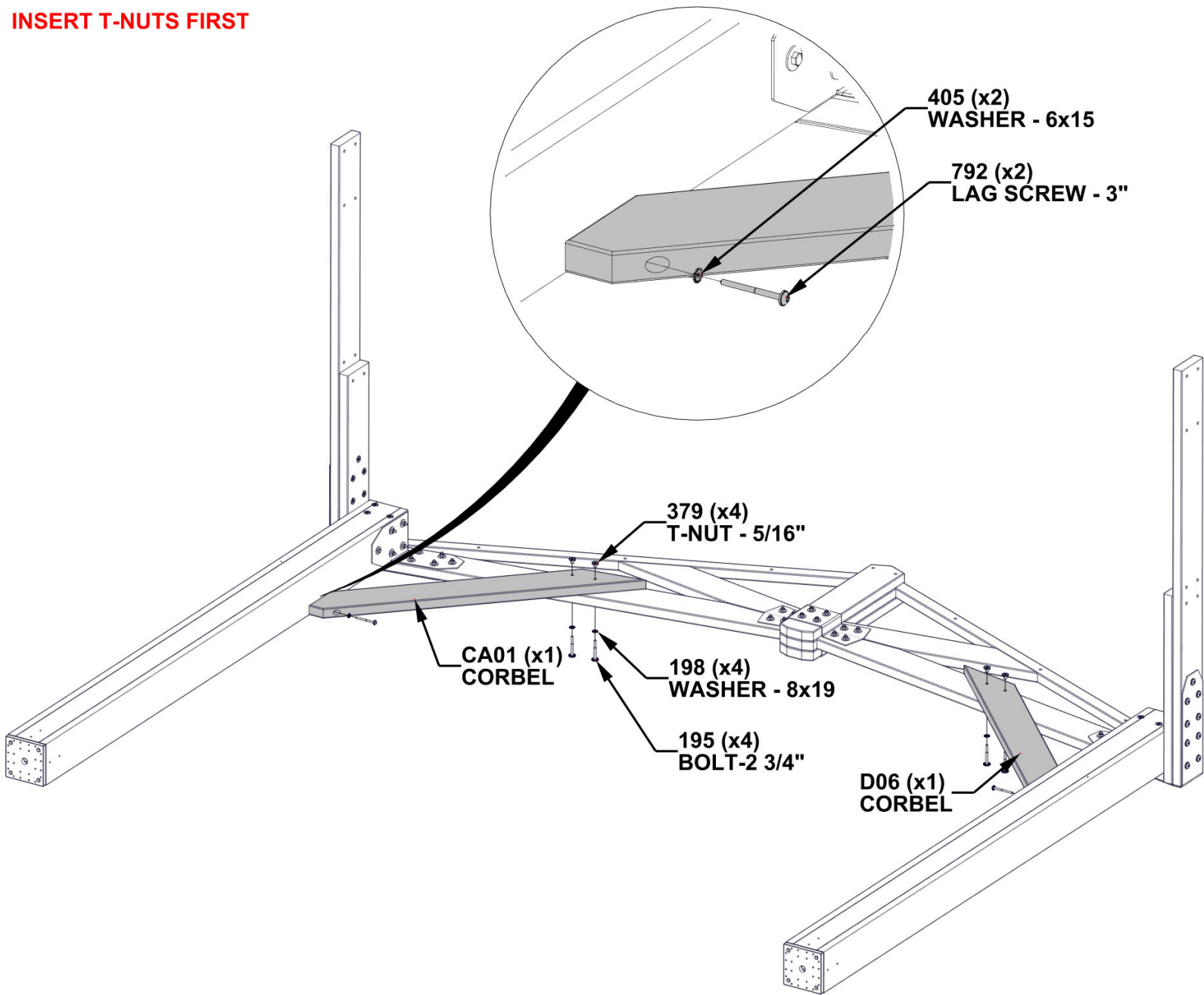

STEP 10 - GAZEBO ASSEMBLY

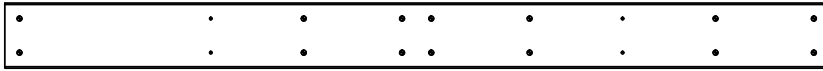

D03 | TOP RAIL - W4L16852
(x2) 1 3/8"x5 1/4"x66 5/8" (36x134x1692)



D04 | CORBEL - W4L16853
(x2) 1 3/8"x5 1/4"x35 7/8" (36x134x910)

| QTY | PART NUMBER | DESCRIPTION |
|-----|-------------|--------------------------|
| 8 | H100195 | BOLT WH 5/16 X 2 3/4 BLK |
| 16 | H100198 | WASHER LOCK EXT 8X19 BLK |
| 4 | H100201 | SCREW PFH 8 X 2 1/2 BLK |
| 32 | H100379 | T-NUT 5/16 BLK |
| 2 | H100405 | WASHER LOCK EXT 6X15 BLK |
| 8 | H100513 | BOLT WH 5/16 X 4 1/4 BLK |
| 2 | H100792 | LAG SCREW WH 1/4 X 3 BLK |

INSERT T-NUTS FIRST

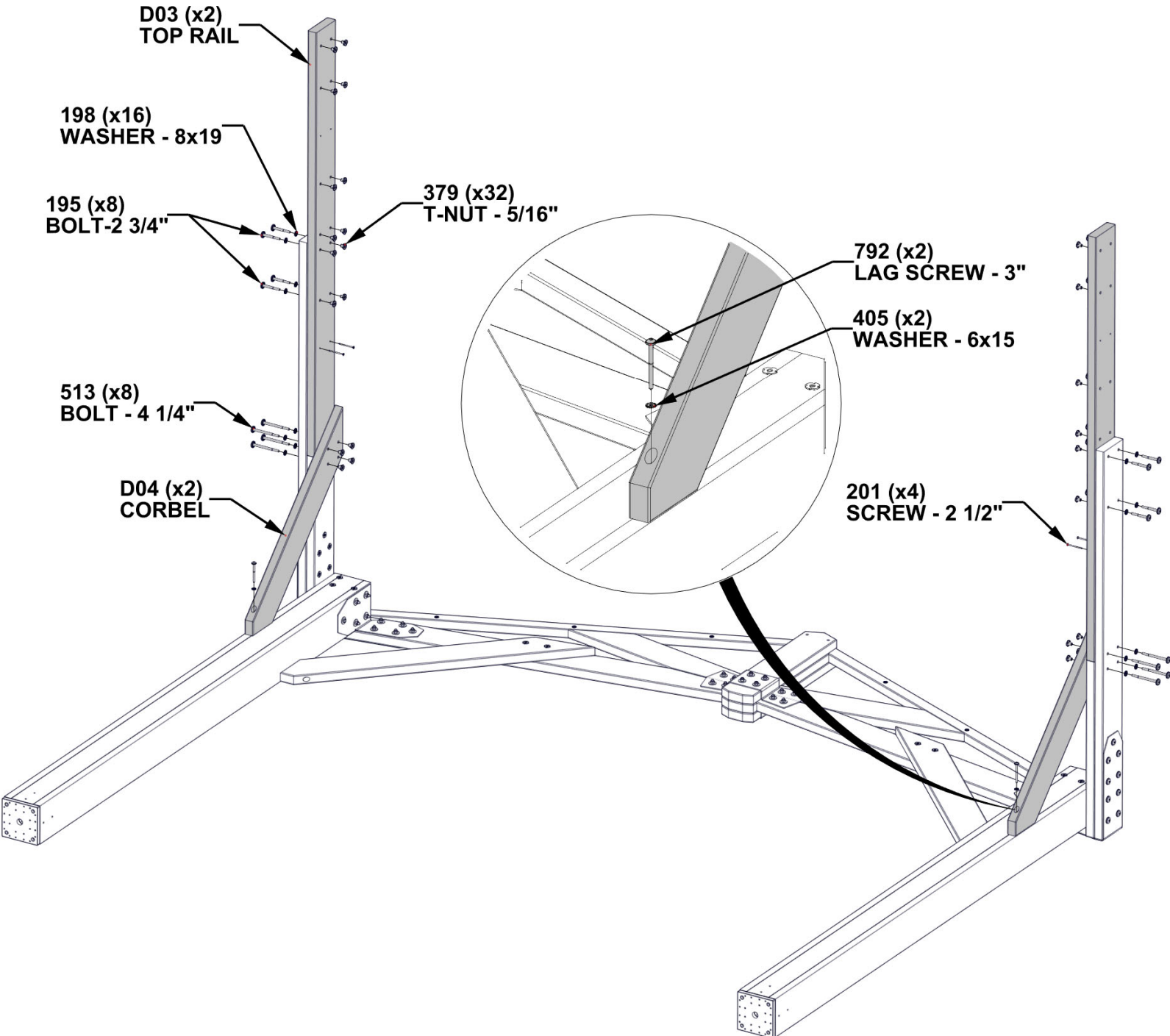

**REPEAT POST AND GABLE ASSEMBLY
STEPS 4 THROUGH 10**

STEP 11 - GAZEBO ASSEMBLY



H08 | NOTCHED SUPPORT BOARD - W4L16915
(x2) | 1"x3 3/8"x89 1/2" (24x86x2274)

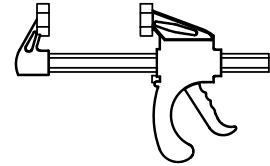

A6P00460 | 6" QUICK RELEASE
(x2) | BAR CLAMP

USING THE INCLUDED CLAMPS AND H08 BOARDS, STAND UP ONE GABLE END AND SECURELY CLAMP AS SHOWN. ADDITIONAL HELPERS ARE RECOMMENDED FOR THIS STEP.

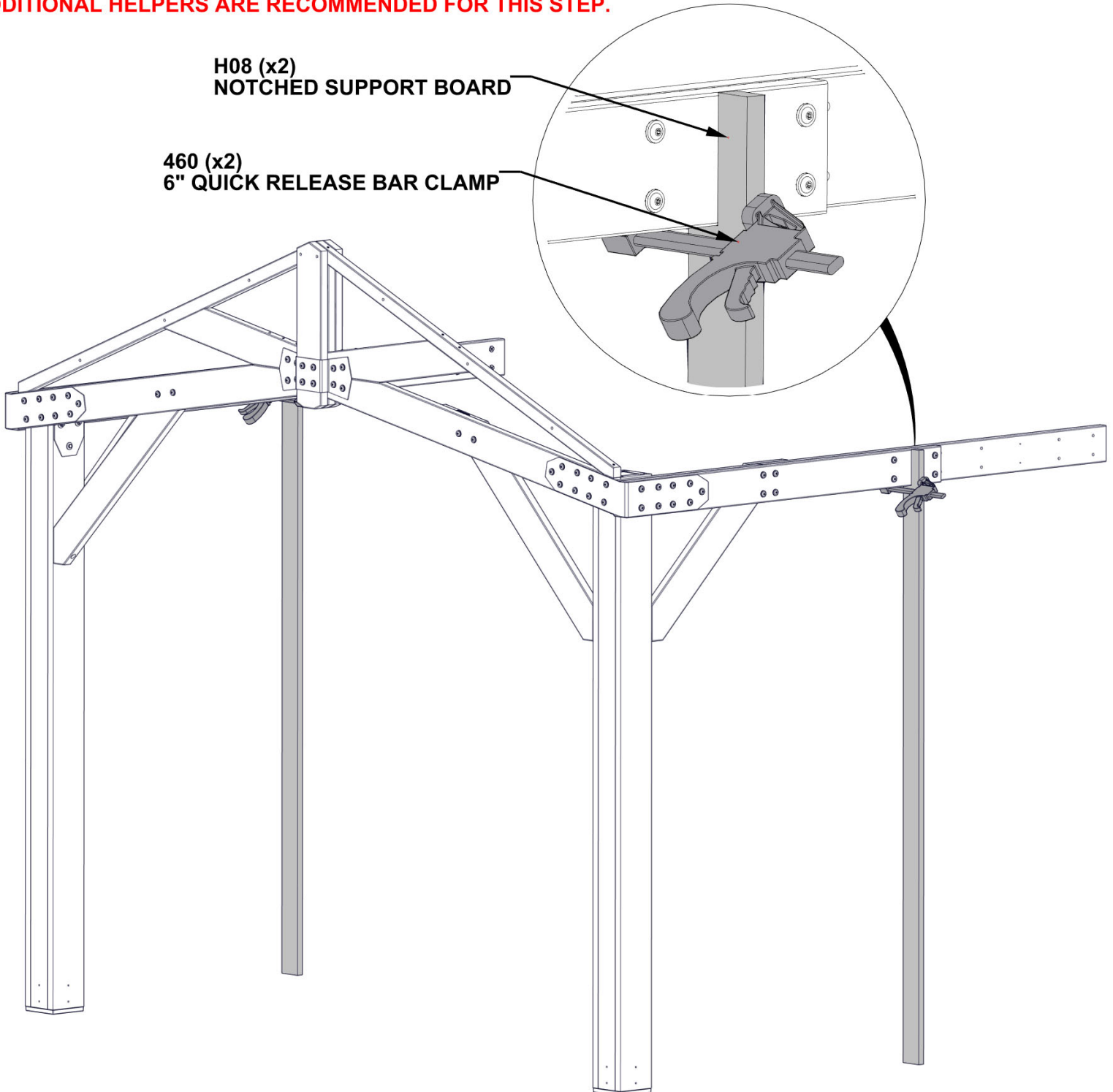

STEP 12 - GAZEBO ASSEMBLY

| QTY | PART NUMBER | DESCRIPTION |
|-----|-------------|--------------------------|
| 16 | H100195 | BOLT WH 5/16 X 2 3/4 BLK |
| 16 | H100198 | WASHER LOCK EXT 8X19 BLK |
| 4 | H100201 | SCREW PFH 8 X 2 1/2 BLK |

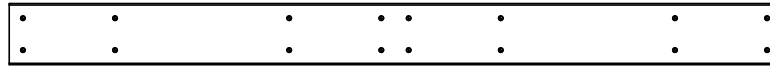

D08 TOP RAIL - W4L16857
(x2) 1 3/8"x5 1/4"x66 5/8" (36x134x1692)

INSERT T-NUTS FIRST

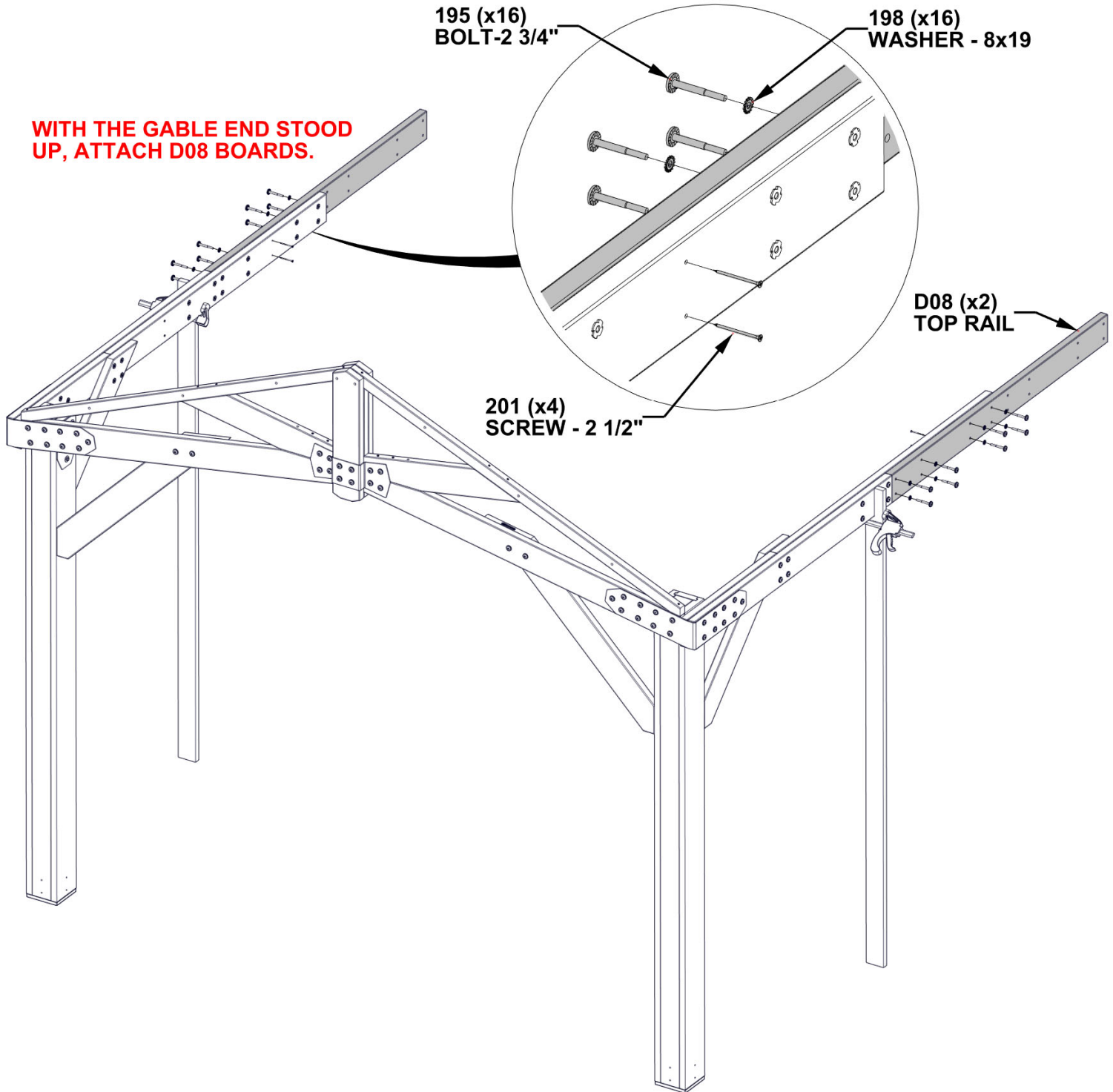

STEP 13 - GAZEBO ASSEMBLY

| QTY | PART NUMBER | DESCRIPTION |
|-----|-------------|--------------------------|
| 16 | H100195 | BOLT WH 5/16 X 2 3/4 BLK |
| 16 | H100198 | WASHER LOCK EXT 8X19 BLK |
| 4 | H100201 | SCREW PFH 8 X 2 1/2 BLK |

INSERT T-NUTS FIRST

STAND UP OTHER GABLE END AND ATTACH HARDWARE AS SHOWN. ONCE ALL HARDWARE IS SECURELY ATTACHED, REMOVE CLAMPS AND H08 BOARDS.

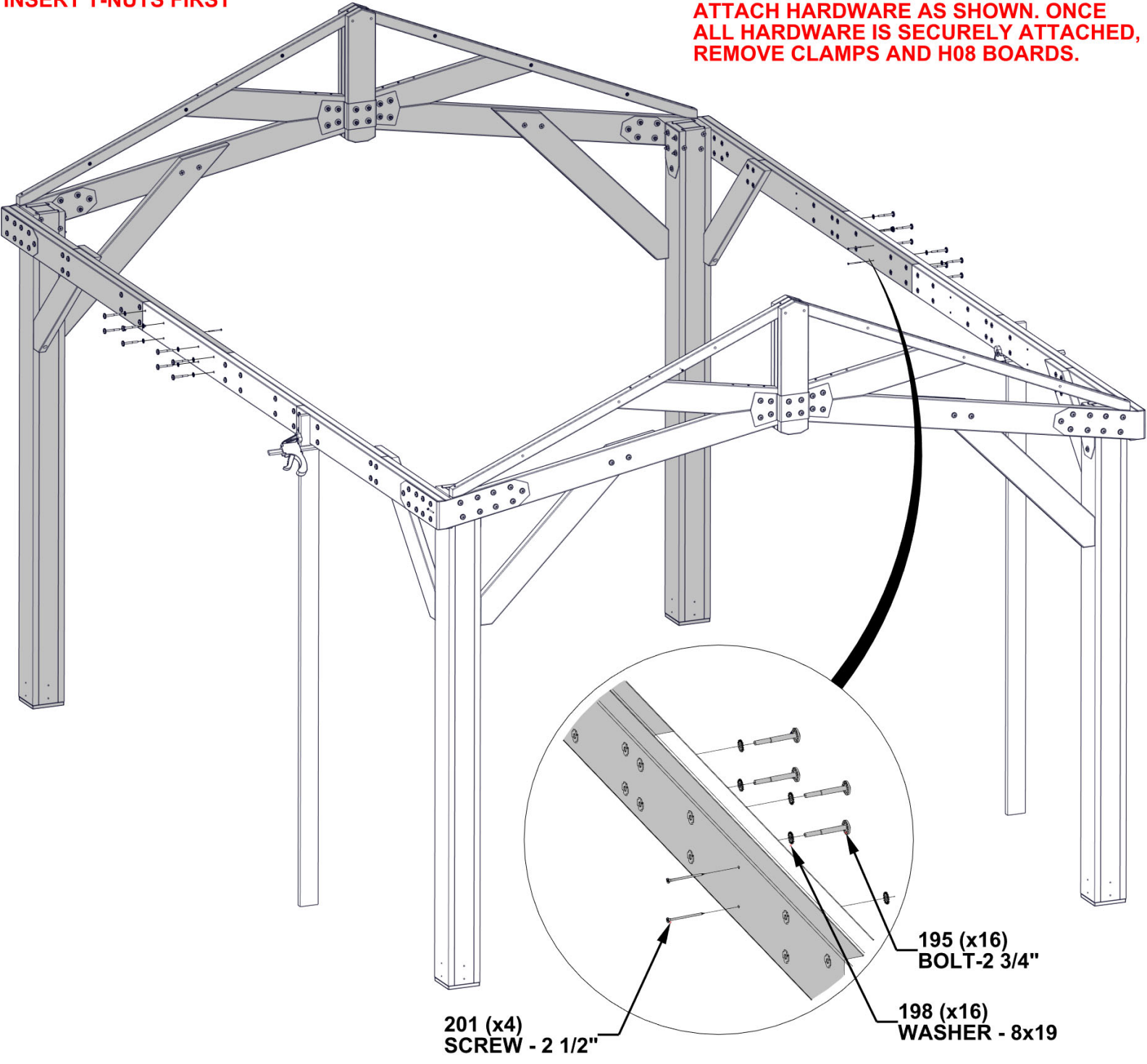

STEP 14 - GAZEBO ASSEMBLY

| QTY | PART NUMBER | DESCRIPTION |
|-----|-------------|-------------------------|
| 16 | H100201 | SCREW PFH 8 X 2 1/2 BLK |



E02 | TRUSS - W4L16859
(x4) | 1 7/16"x1 15/16"x74 15/16" (36x50x1902)

FLUSH TOPS

**ALIGN HOLES FOR
CORRECT ORIENTATION.**

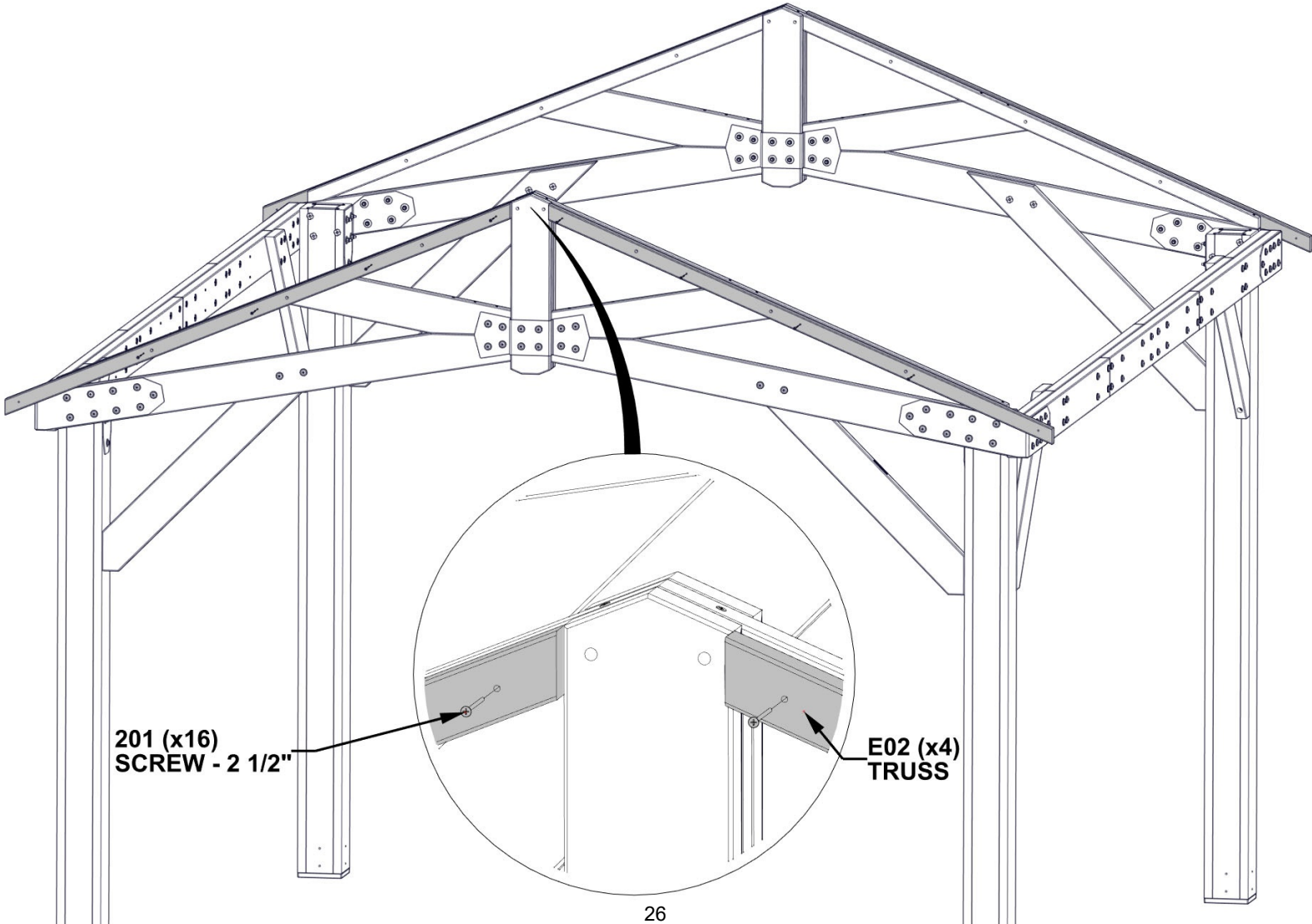
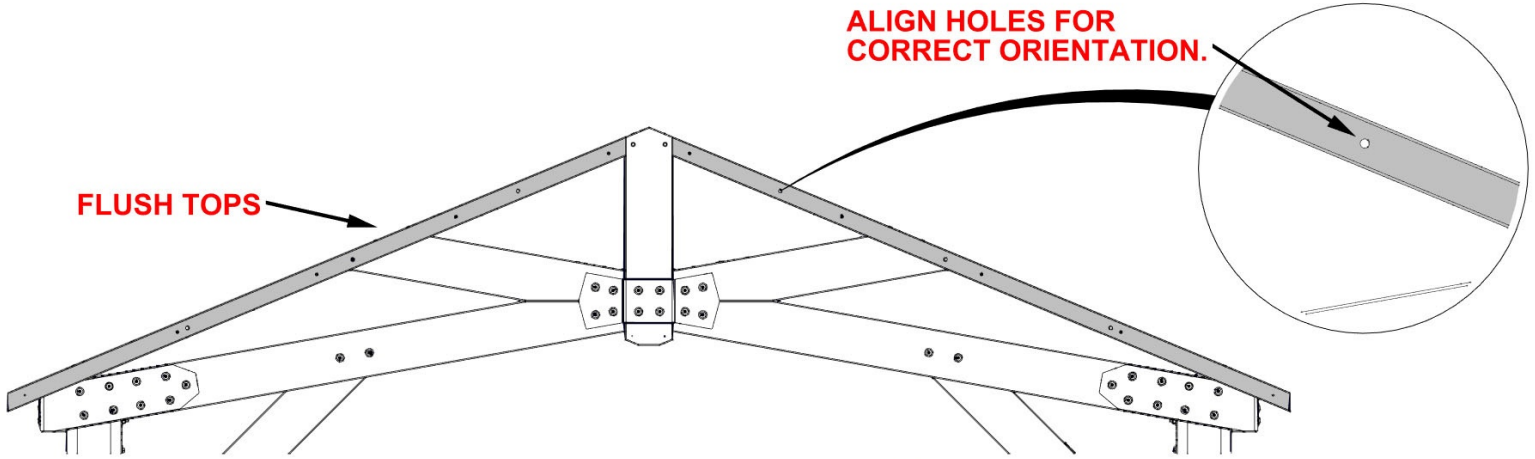

**201 (x16)
SCREW - 2 1/2"**

**E02 (x4)
TRUSS**

STEP 15 - GAZEBO ASSEMBLY

| QTY | PART NUMBER | DESCRIPTION |
|-----|-------------|--------------------------|
| 4 | H100201 | SCREW PFH 8 X 2 1/2 BLK |
| 12 | H100405 | WASHER LOCK EXT 6X15 BLK |
| 12 | H100564 | LAG SCREW WH 1/4 X 4 BLK |

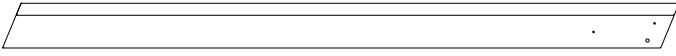

GP1 | GABLE PANEL - W2A03499
(x2) | 2 13/16"x5 1/4"x80 3/16" (72x134x2037)

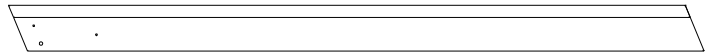

GP2 | GABLE PANEL - W2A03500
(x2) | 2 13/16"x5 1/4"x80 3/16" (72x134x2037)

TEMPORARILY INSERT 354 BOLTS TO ALIGN GABLE PANEL WITH GABLE.

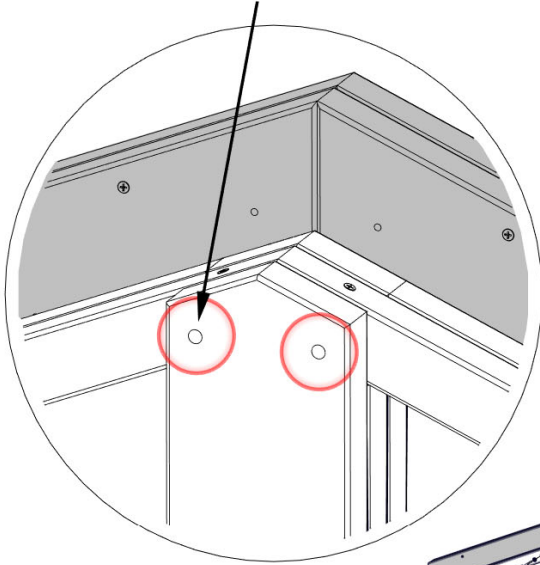

405 (x12)
WASHER - 6x15

564 (x12)
LAG SCREW - 4"

201 (x4)
SCREW - 2 1/2"

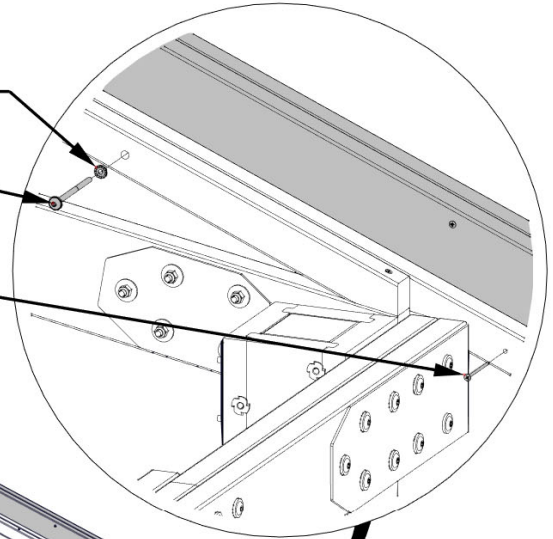

GP1 (x2)
GABLE PANEL

GP2 (x2)
GABLE PANEL

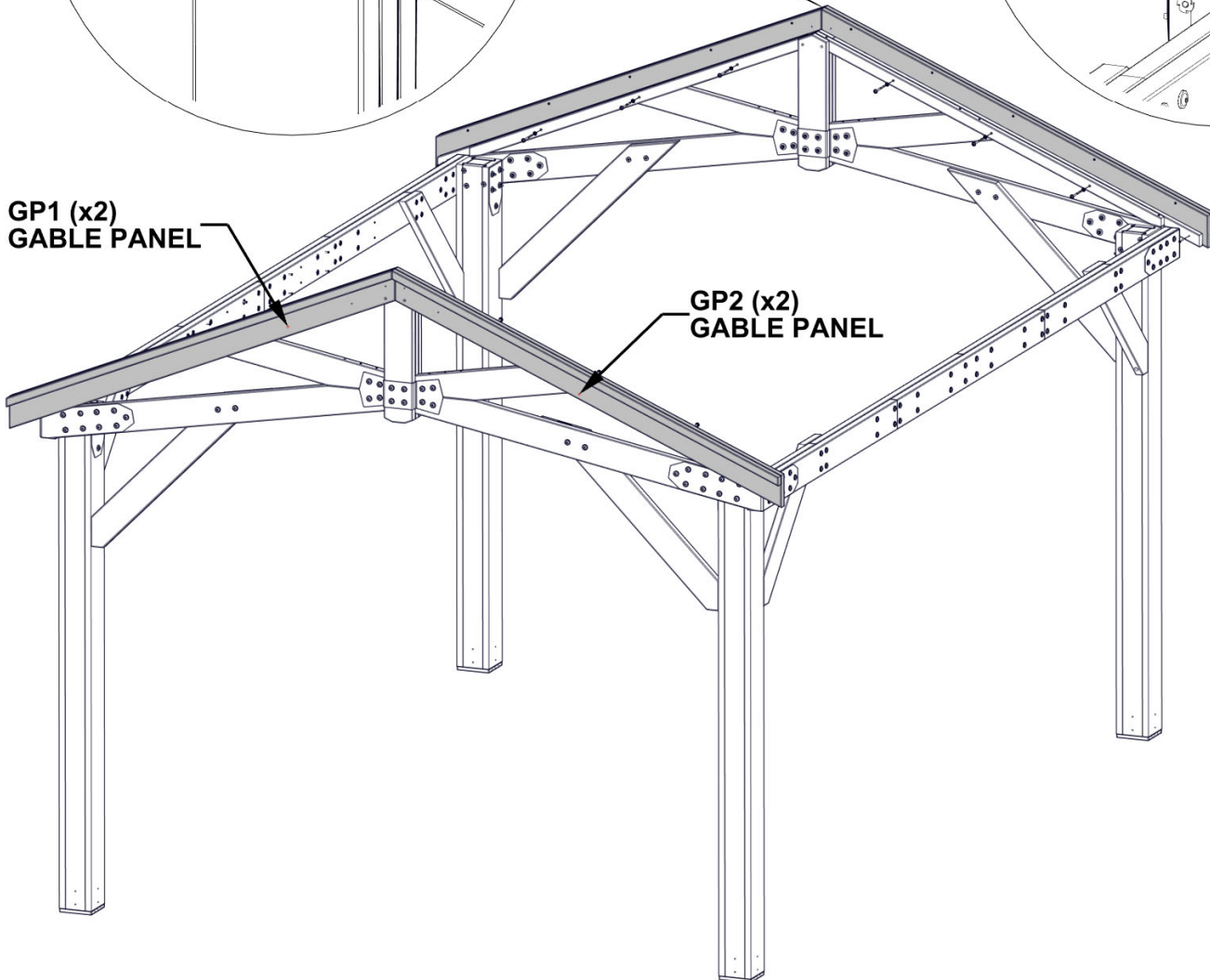

STEP 16 - GAZEBO ASSEMBLY

| QTY | PART NUMBER | DESCRIPTION |
|-----|-------------|-------------------------------|
| 4 | H100200 | SCREW PFH 8 X 1 1/2 BLK |
| 4 | H100354 | BOLT WH 5/16 X 6 1/2 BLK |
| 8 | H100471 | LAG SCREW WH 5/16 X 1 1/2 BLK |
| 4 | H100478 | WASHER FLAT 8X27 BLK |
| 4 | H100479 | NUT LOCK 5/16 BLK |

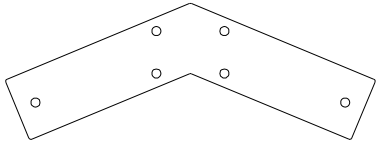

A4M01130 | GABLE BRACKET
(x2)

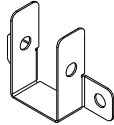

A4M01148 | TRUSS BRACKET
(x2)

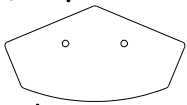

A4M01147 | PEAK SEAM BRACKET
(x2)

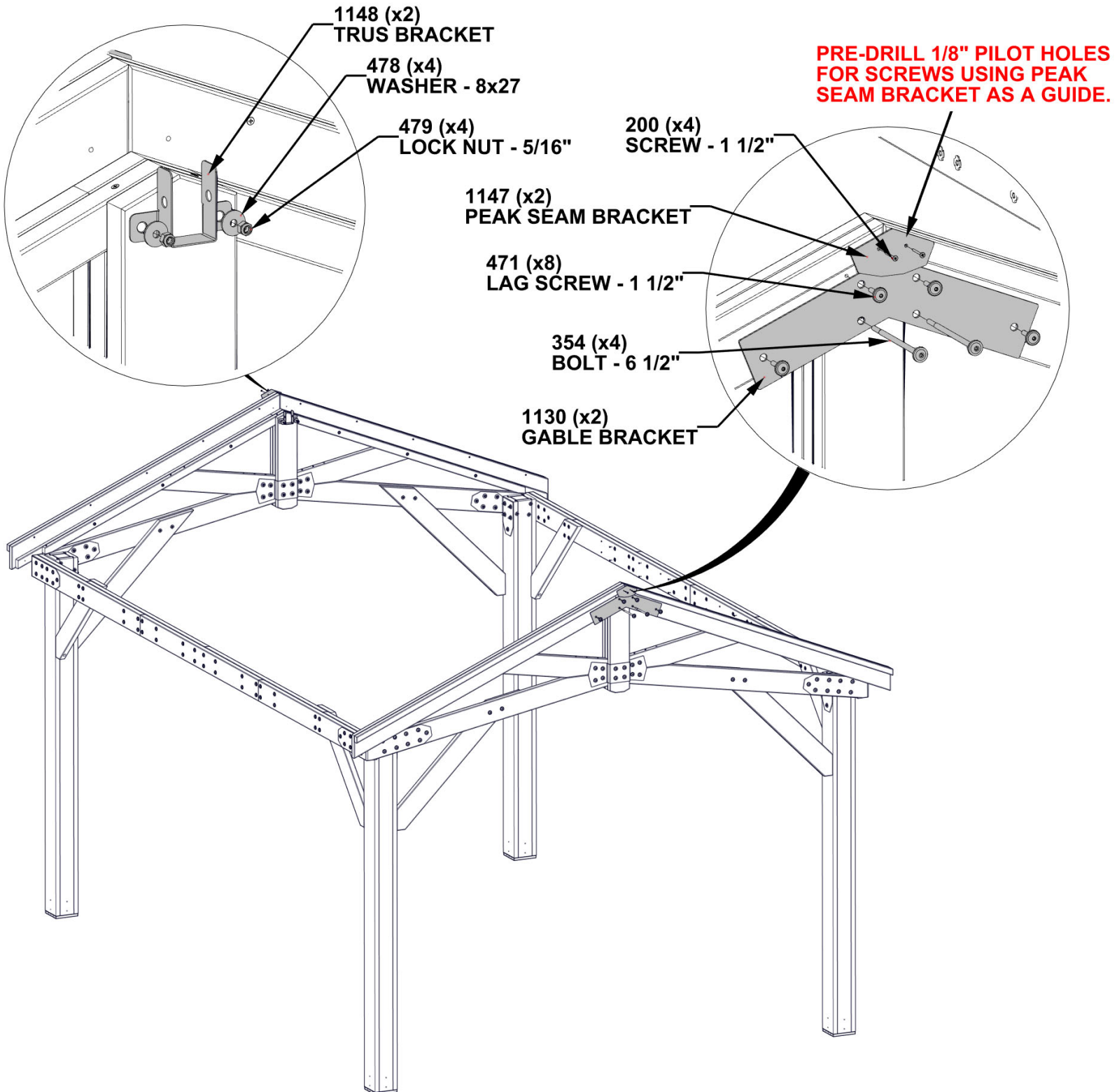

STEP 17 - RAFTER ASSEMBLY

| QTY | PART NUMBER | DESCRIPTION |
|-----|-------------|--------------------------|
| 10 | H100198 | WASHER LOCK EXT 8X19 BLK |
| 26 | H100379 | T-NUT 5/16 BLK |
| 8 | H100382 | SCREW PFH 8 X 1 3/4 BLK |
| 10 | H100459 | BOLT WH 5/16 X 1 1/4 BLK |

AD01 | RAFTER - W4L16866
(x2) | 1"x4"x74 3/4" (24x102x1900)

AD02 | RAFTER - W4L16867
(x2) | 1"x4"x66 3/8" (24x102x1686)

AD03 | RAFTER - W4L16868
(x2) | 1"x4"x41 5/8" (24x102x1057)

INSERT T-NUTS FIRST

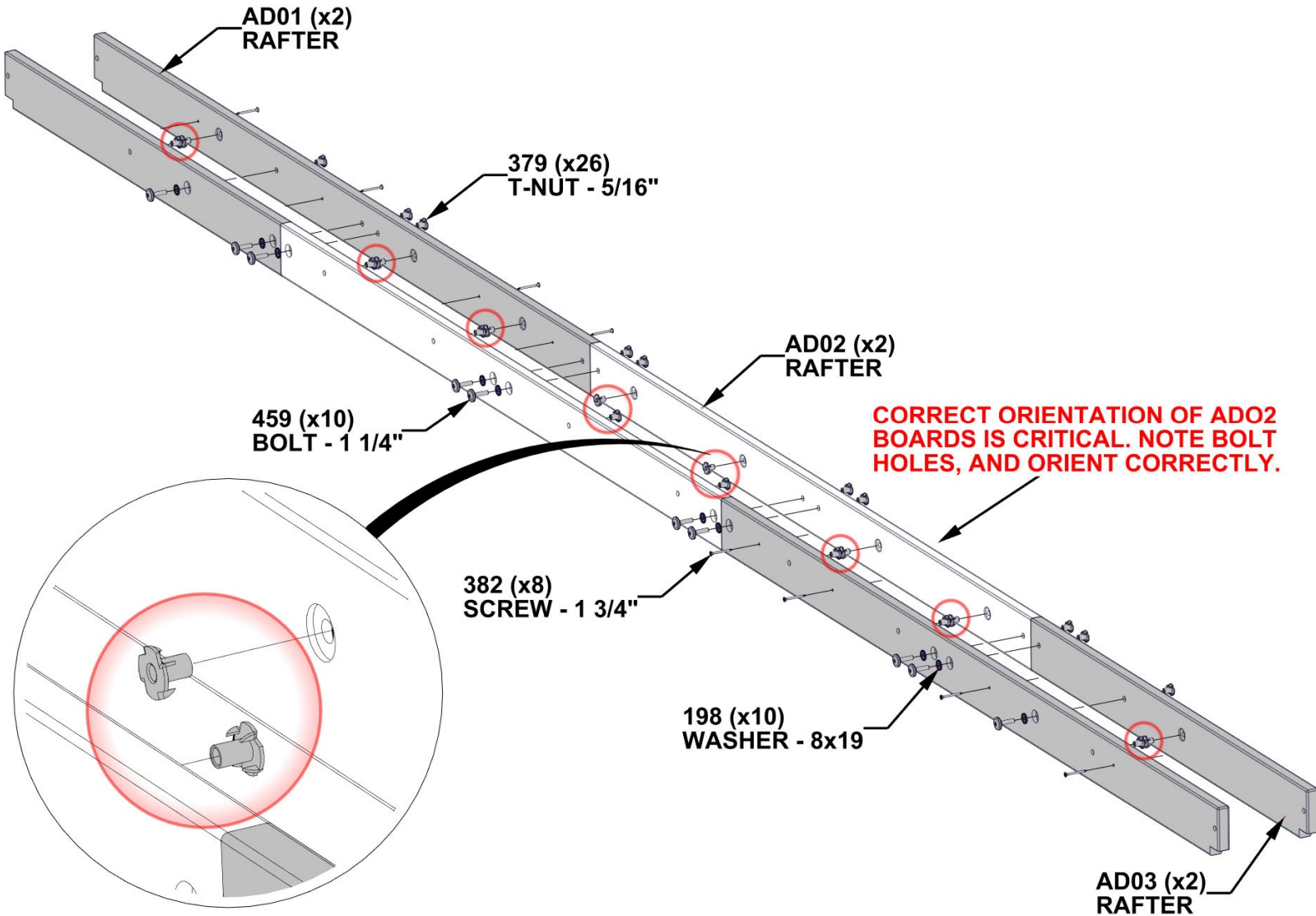

INSERT INTERIOR T-NUTS BEFORE ANY OTHER HARDWARE IS ATTACHED.

STEP 18 - RAFTER ASSEMBLY

| QTY | PART NUMBER | DESCRIPTION |
|-----|-------------|--------------------------|
| 2 | H100195 | BOLT WH 5/16 X 2 3/4 BLK |
| 2 | H100478 | WASHER FLAT 8X27 BLK |
| 2 | H100479 | NUT LOCK 5/16 BLK |



RAFTER ASSEMBLY FROM PREVIOUS STEP

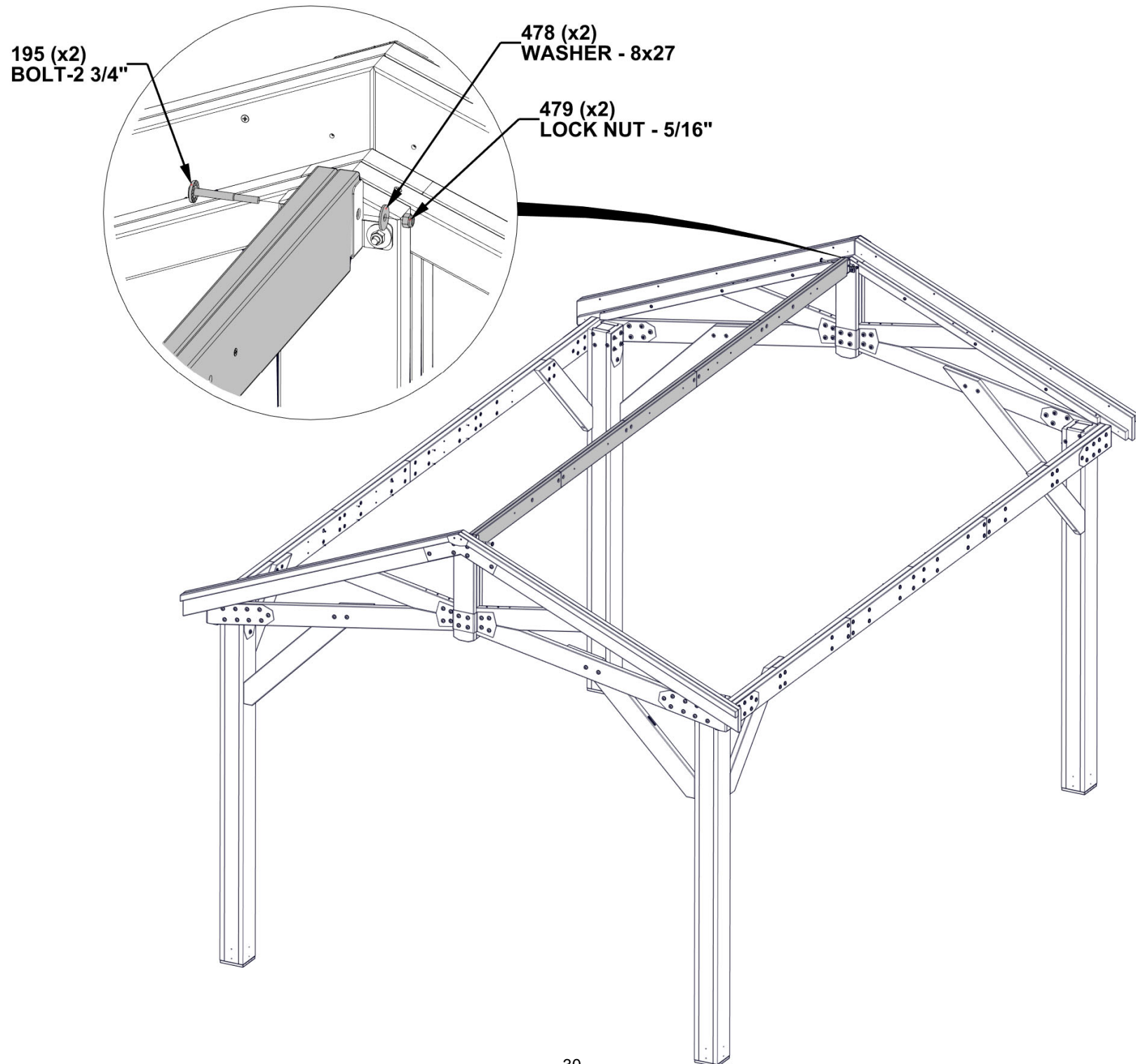

STEP 19 - ROOF PANEL ASSEMBLY

| QTY | PART NUMBER | DESCRIPTION |
|-----|-------------|--------------------------|
| 4 | H100198 | WASHER LOCK EXT 8X19 BLK |
| 44 | H100391 | SCREW PFH 8 X 2 BLK |
| 4 | H100478 | WASHER FLAT 8X27 BLK |
| 4 | H100479 | NUT LOCK 5/16 BLK |
| 4 | H100503 | BOLT WH 5/16 X 3 1/2 BLK |

H01 | FASCIA - W4L16869
(x1) | 1"x3 3/8"x57 3/8" (24x86x1458)

H02 | FASCIA - W4L16870
(x1) | 1"x3 3/8"x58 5/8" (24x86x1490)

H03 | FASCIA - W4L16871
(x1) | 1"x3 3/8"x58 3/8" (24x86x1482)

H04 | FASCIA - W4L16872
(x1) | 1"x3 3/8"x57 3/8" (24x86x1458)

H05 | FASCIA - W4L16873
(x1) | 1"x3 3/8"x75 1/8" (24x86x1907)

H06 | FASCIA - W4L16874
(x1) | 1"x3 3/8"x41 7/8" (24x86x1064)

E05 | RAFTER - W4L16862
(x4) | 1 3/8"x3 3/8"x76 3/8" (36x86x1941)

E08 | RAFTER - W4L16865
(x3) | 1 3/8"x3 3/8"x76 3/8" (36x86x1941)

ROOF PANEL A

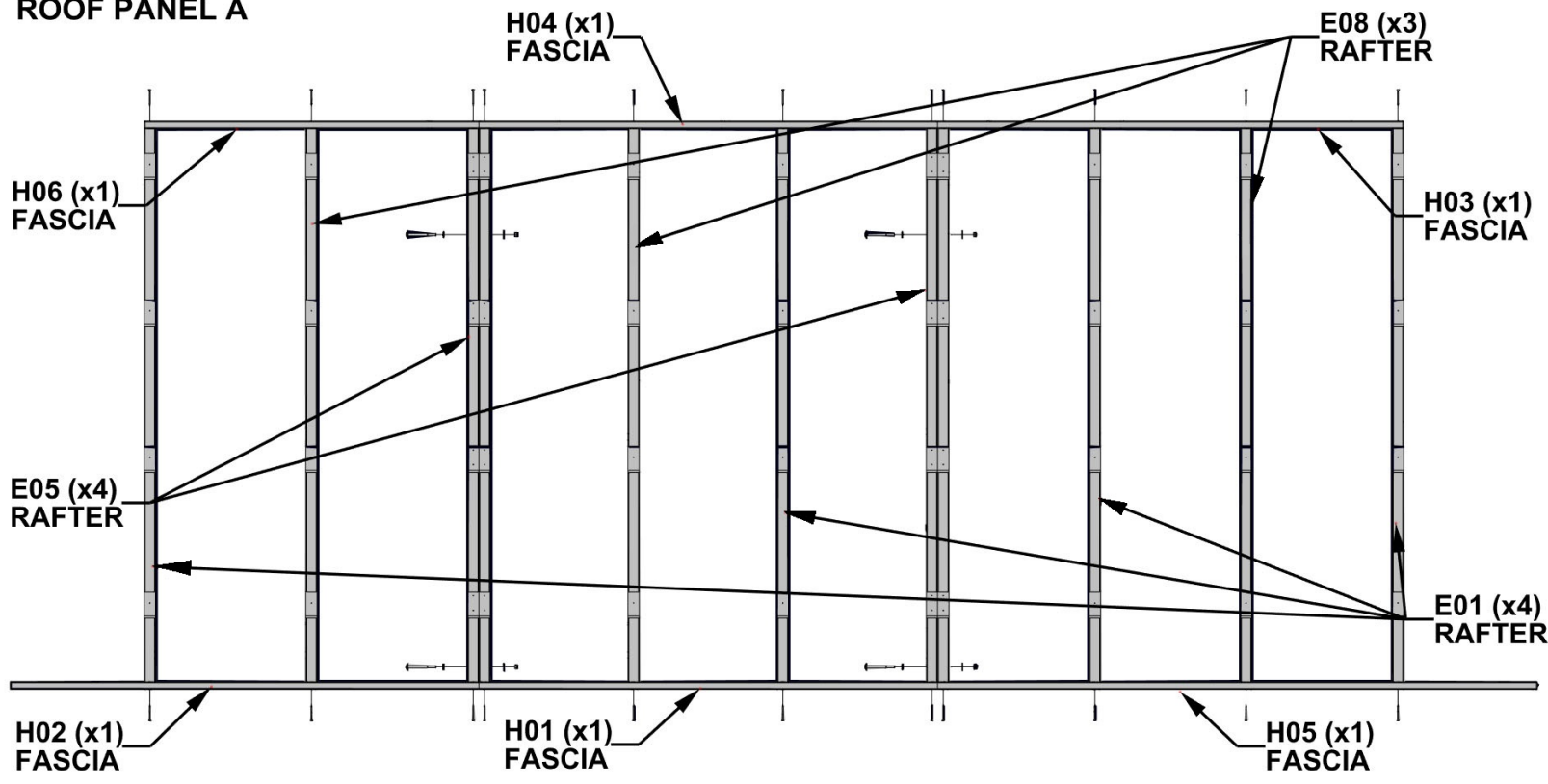

ENSURE ALL RAFTERS ARE PLACED CORRECTLY.

ENSURE H04 IS ORIENTED CORRECTLY. CHECK MEASUREMENTS FROM BOLT HOLE TO END OF BOARD AND ORIENT AS SHOWN.

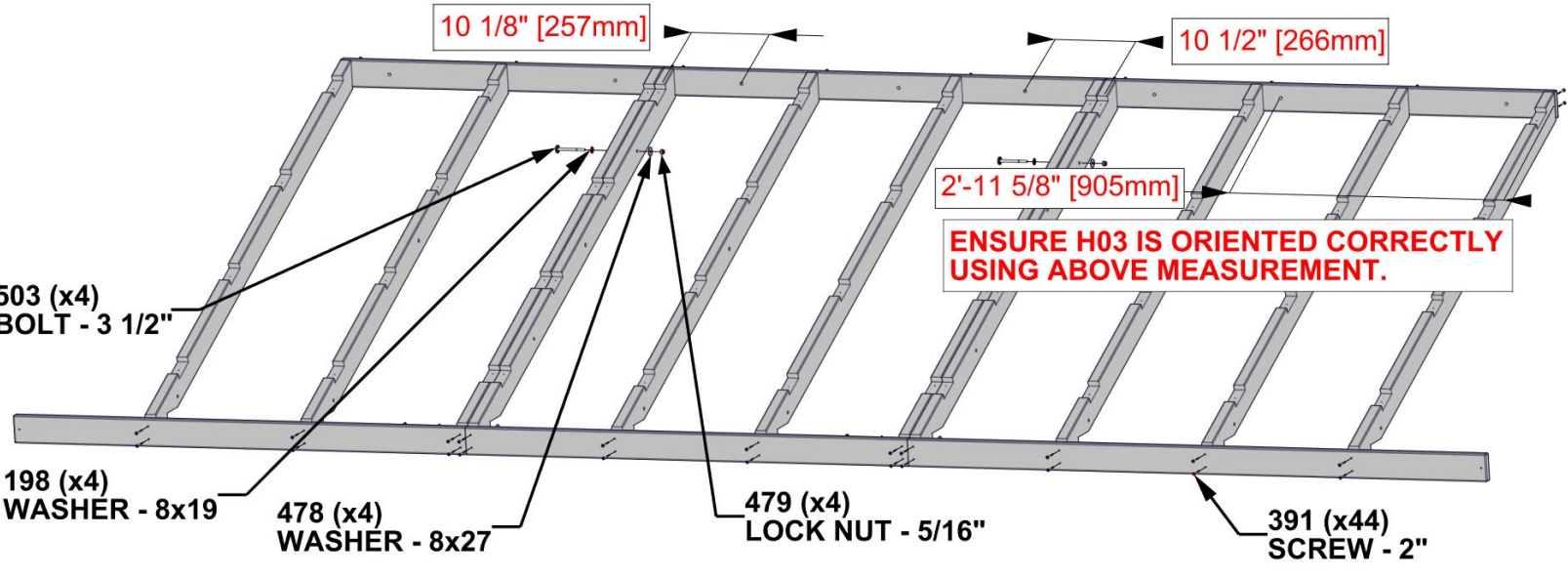

STEP 20A - ROOF PANEL ASSEMBLY

| QTY | PART NUMBER | DESCRIPTION |
|-----|-------------|---------------------|
| 60 | H100391 | SCREW PFH 8 X 2 BLK |

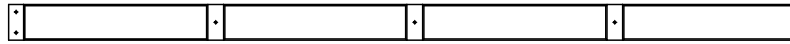

E03 | SHEATHING BOARD - W4L16860
 (x4) | 1 3/8"x5 1/4"x75 1/8" (36x134x1907)



E04 | SHEATHING BOARD - W4L16861
 (x4) | 1 3/8"x3 3/8"x57 3/8" (36x86x1458)



E07 | SHEATHING BOARD - W4L16864
 (x4) | 1 3/8"x3 3/8"x58 5/8" (36x86x1490)

ROOF PANEL A

E07 (x4)
SHEATHING BOARD

E04 (x4)
SHEATHING BOARD

E03 (x4)
SHEATHING BOARD

391 (x60)
SCREW - 2"

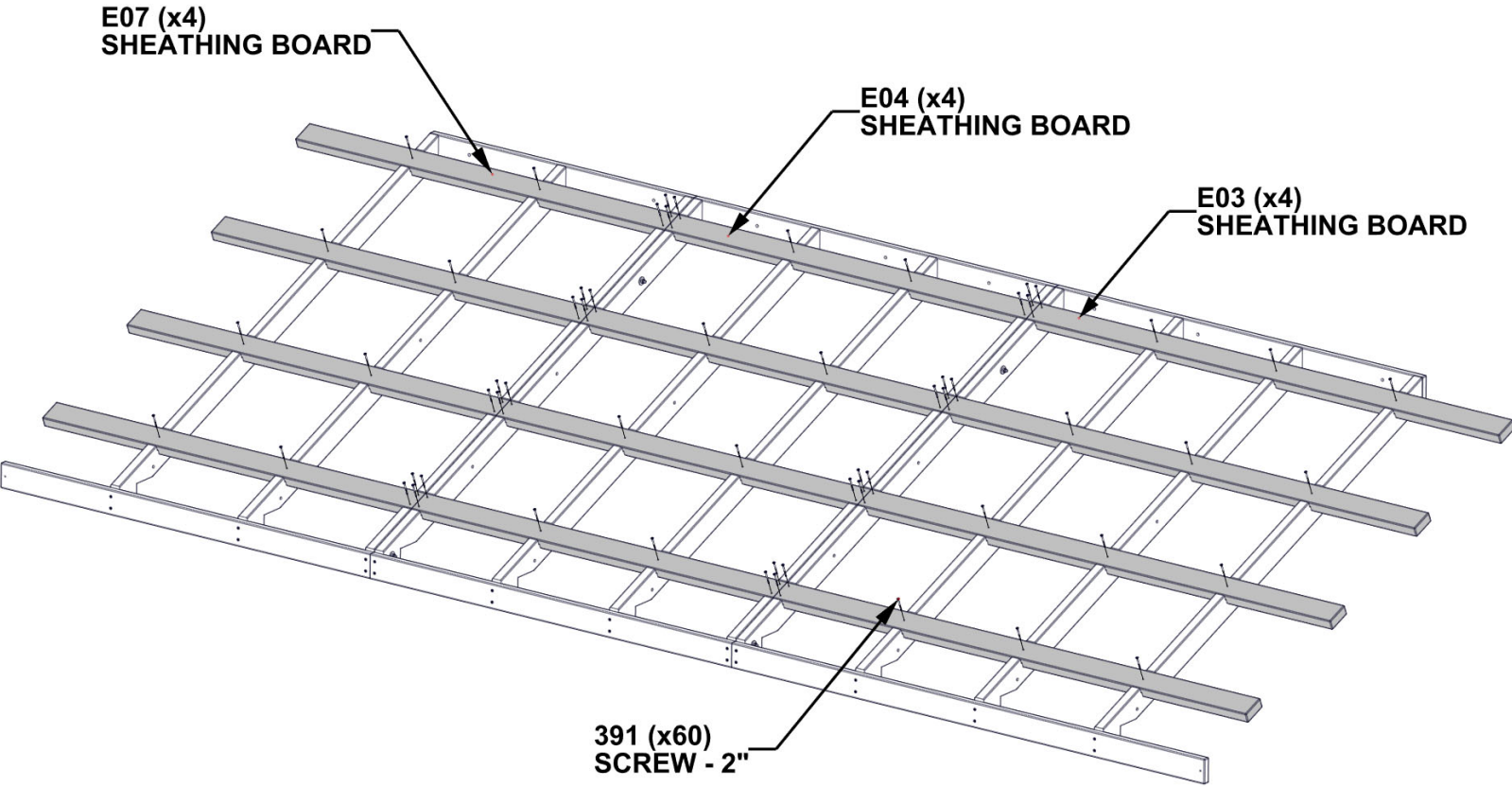

STEP 20B - ROOF PANEL ASSEMBLY

ROOF PANEL A

TIP: LOOSEN HARDWARE TO ADJUST FOR SQUARING IF NEEDED

CRITICAL:

- SQUARE UNIT BEFORE PROCEEDING TO NEXT STEPS.
- THE BELOW DIMENSIONS ARE CRITICAL TO THE FINAL ROOF ASSEMBLY.
- MEASUREMENTS SHOULD BE HELD WITHIN +/- 1/4".
- MEASUREMENTS OUTSIDE OF TOLERANCE WILL LEAD TO THE INABILITY TO ASSEMBLY THE ROOF.

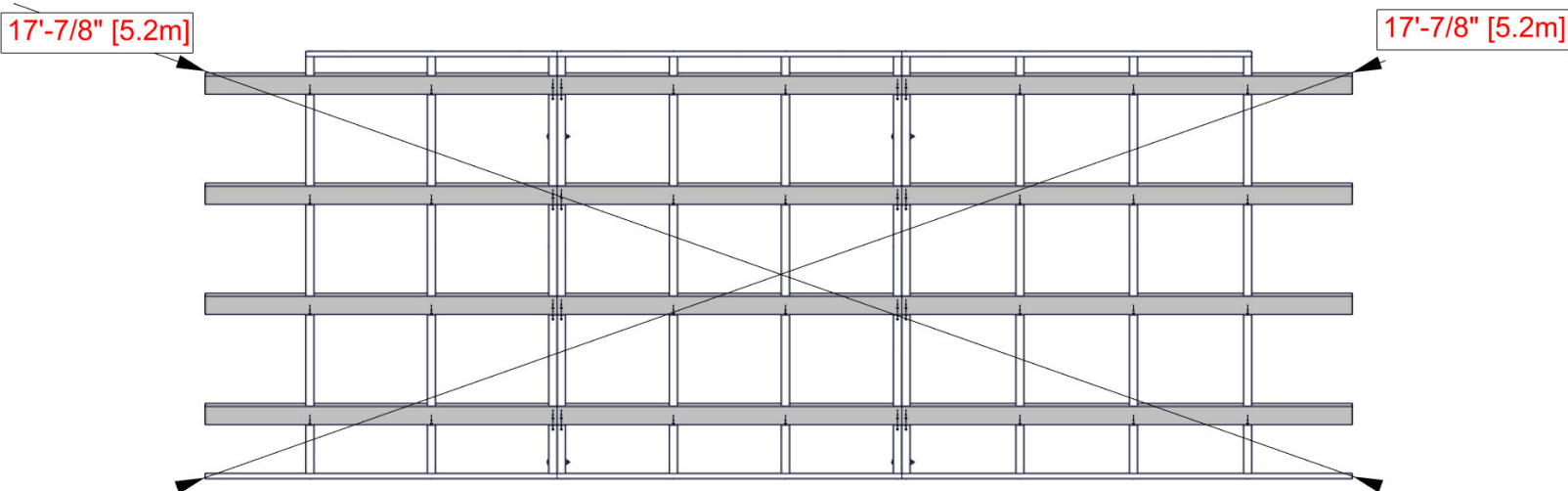

STEP 21 - ROOF PANEL ASSEMBLY

ROOF PANEL A

USE THIS PAGE TO FAMILIARIZE YOURSELF WITH THE ROOF PANEL AND ASSIST YOU IN STEPS 22-24.

TIPS:

- REMOVE PROTECTIVE BLUE FILM
- START AT THE END INDICATED AND ASSEMBLE IN THE DIRECTION OF THE ARROW

GLOVES SHOULD BE WORN WHEN HANDLING ROOF PANELS: EDGES ARE SHARP.

THE PRE-DRILLED HOLES ON EACH PANEL SHOULD ALWAYS BE POSITIONED ON THE RIDGE SIDE.

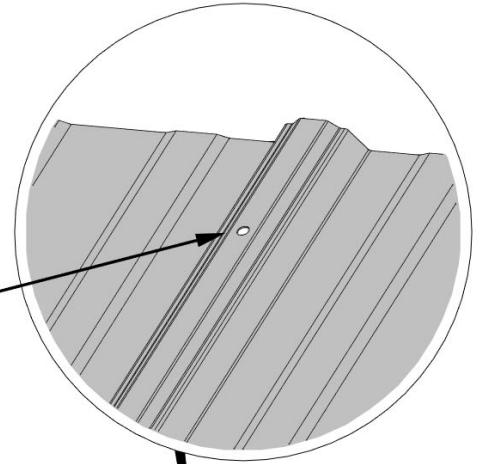

RIDGE

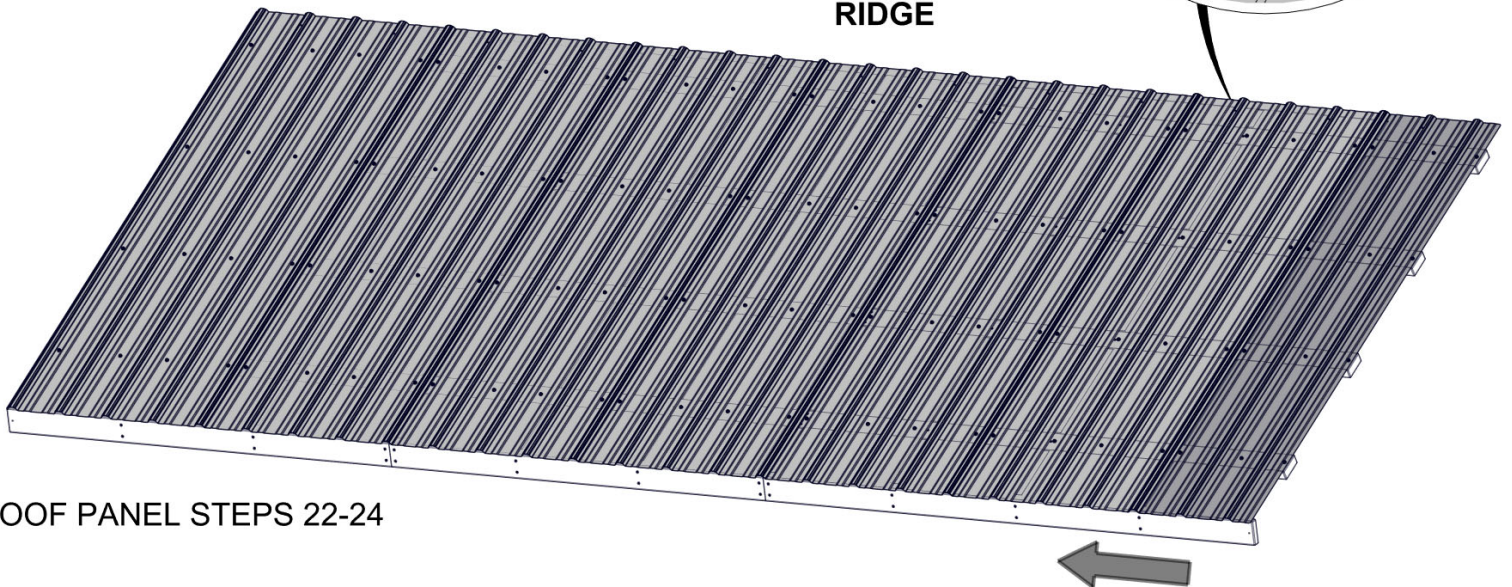

ROOF PANEL STEPS 22-24

STEP 22 - ROOF PANEL ASSEMBLY

| QTY | PART NUMBER | DESCRIPTION |
|-----|-------------|----------------------------|
| 44 | H100833 | SCREW WOODGRIP 10-16 x 3/4 |

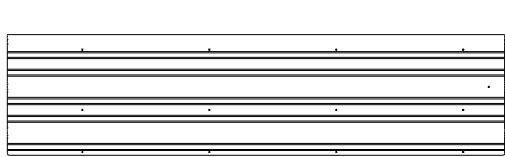

A4M01371 (x1) | 29 GA STEEL SHEETING

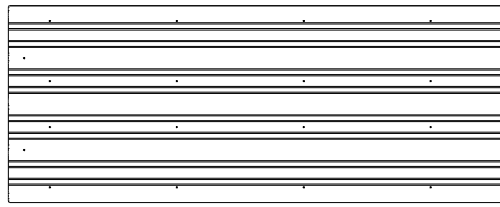

A4M01124 (x1) | 29 GA STEEL SHEETING

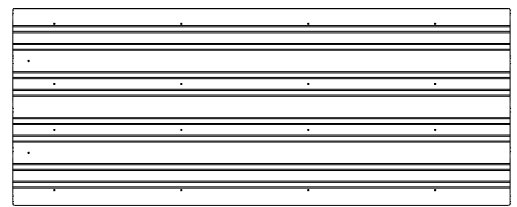

A4M01715 (x1) | 29 GA STEEL SHEETING

ROOF PANEL A

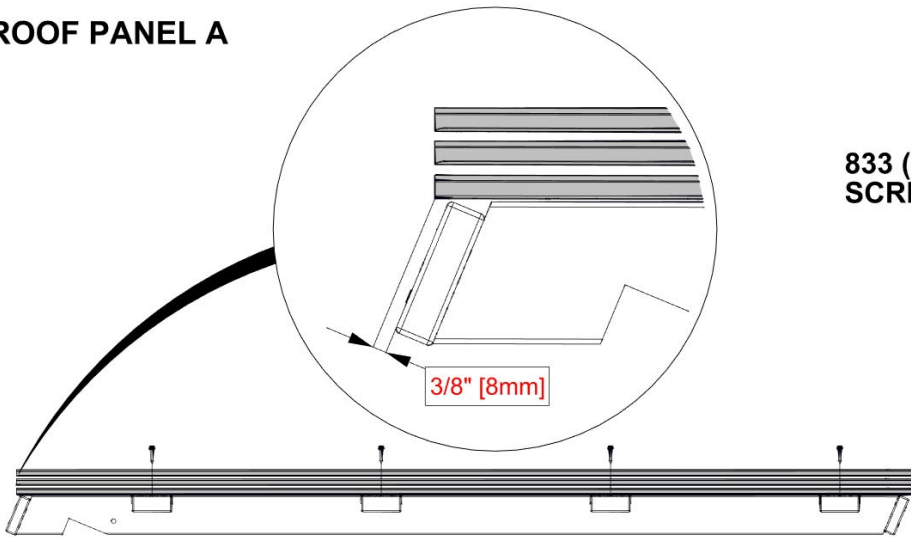

MAKE SURE YOUR ROOF PANEL IS SQUARE BEFORE MOVING ON.

833 (x44)
SCREW - 3/4"

NOTE RIB OVERLAP

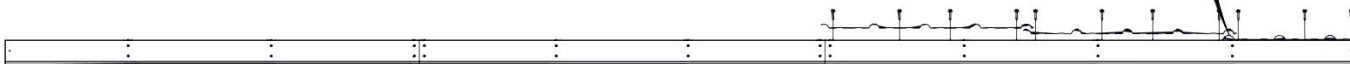
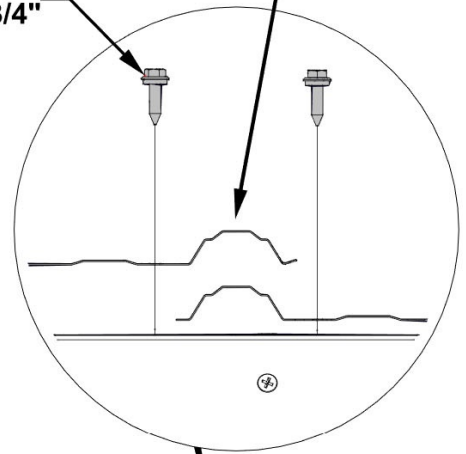

1371 (x1)
29 GA STEEL SHEETING

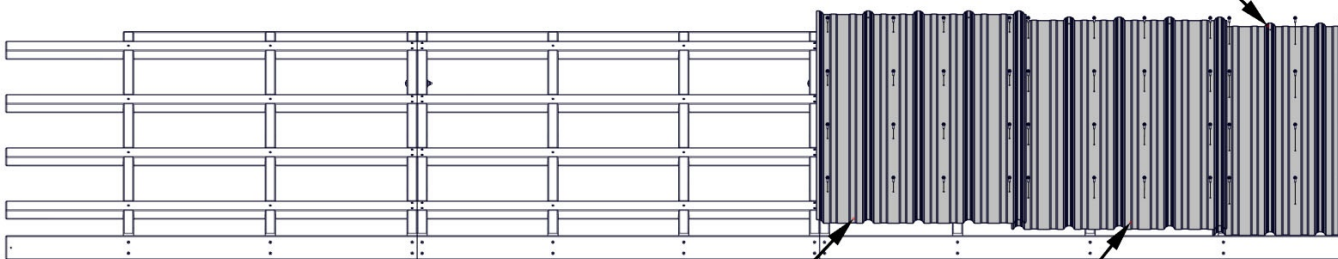

1715 (x1)
29 GA STEEL SHEETING

ENSURE CORRECT PLACEMENT OF 1715 STEEL SHEETING.

1124 (x1)
29 GA STEEL SHEETING

HOLD SHEETING INSIDE OF FRAME MEASURING FROM RIB AS SHOWN.

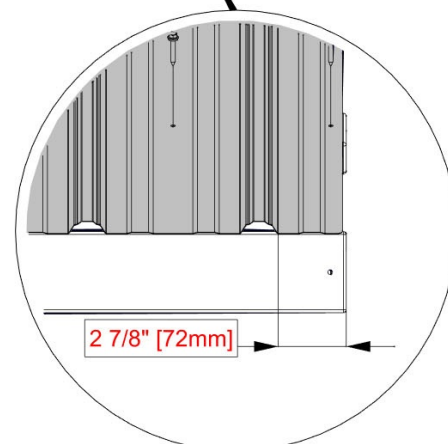

STEP 23 - ROOF PANEL ASSEMBLY

| QTY | PART NUMBER | DESCRIPTION |
|-----|-------------|----------------------------|
| 32 | H100833 | SCREW WOODGRIP 10-16 x 3/4 |



A4M01124 (x1) | 29 GA STEEL SHEETING

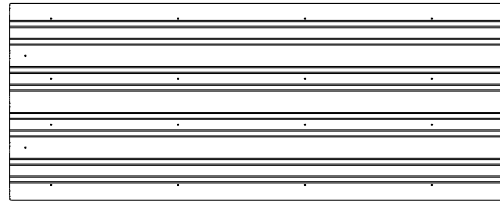

A4M01715 (x1) | 29 GA STEEL SHEETING

ROOF PANEL A

833 (x32)
SCREW - 3/4"

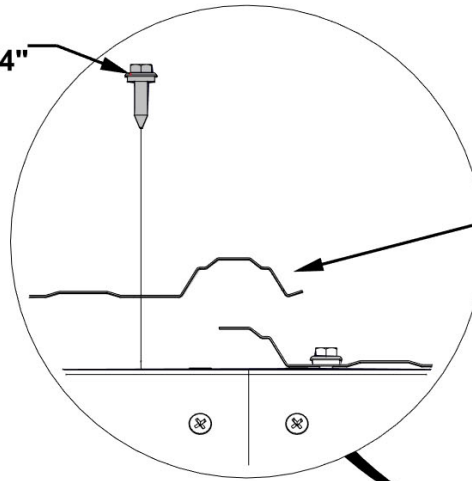

NOTE RIB OVERLAP

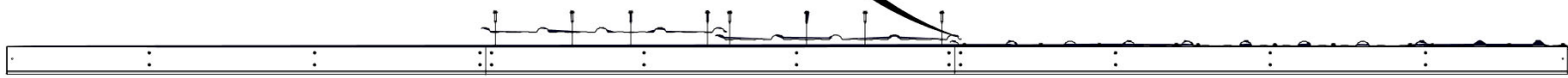

ENSURE CORRECT PLACEMENT OF 1715 STEEL SHEETING.

1715 (x1)
29 GA STEEL SHEETING

1124 (x1)
29 GA STEEL SHEETING

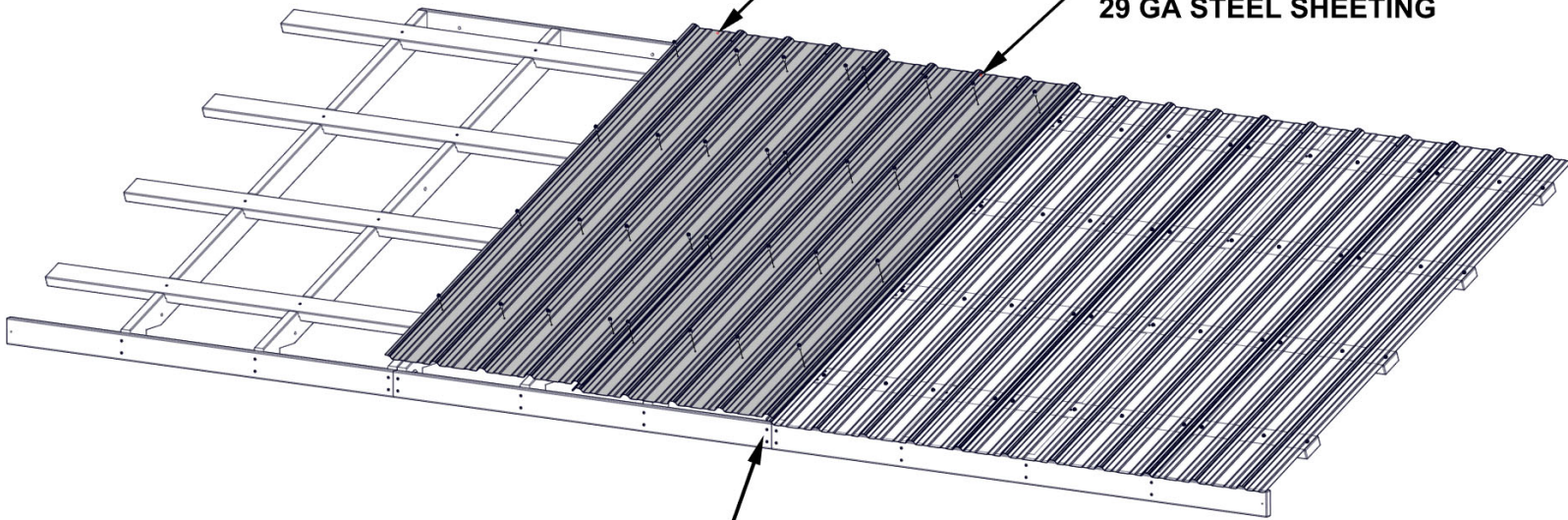

FLUSH ENDS OF ALL SHEETS

STEP 24 - ROOF PANEL ASSEMBLY

| QTY | PART NUMBER | DESCRIPTION |
|-----|-------------|----------------------------|
| 32 | H100833 | SCREW WOODGRIP 10-16 x 3/4 |

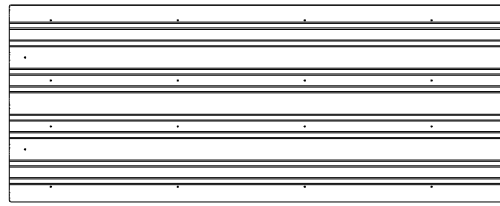

A4M01124 (x2) | 29 GA STEEL SHEETING

ROOF PANEL A

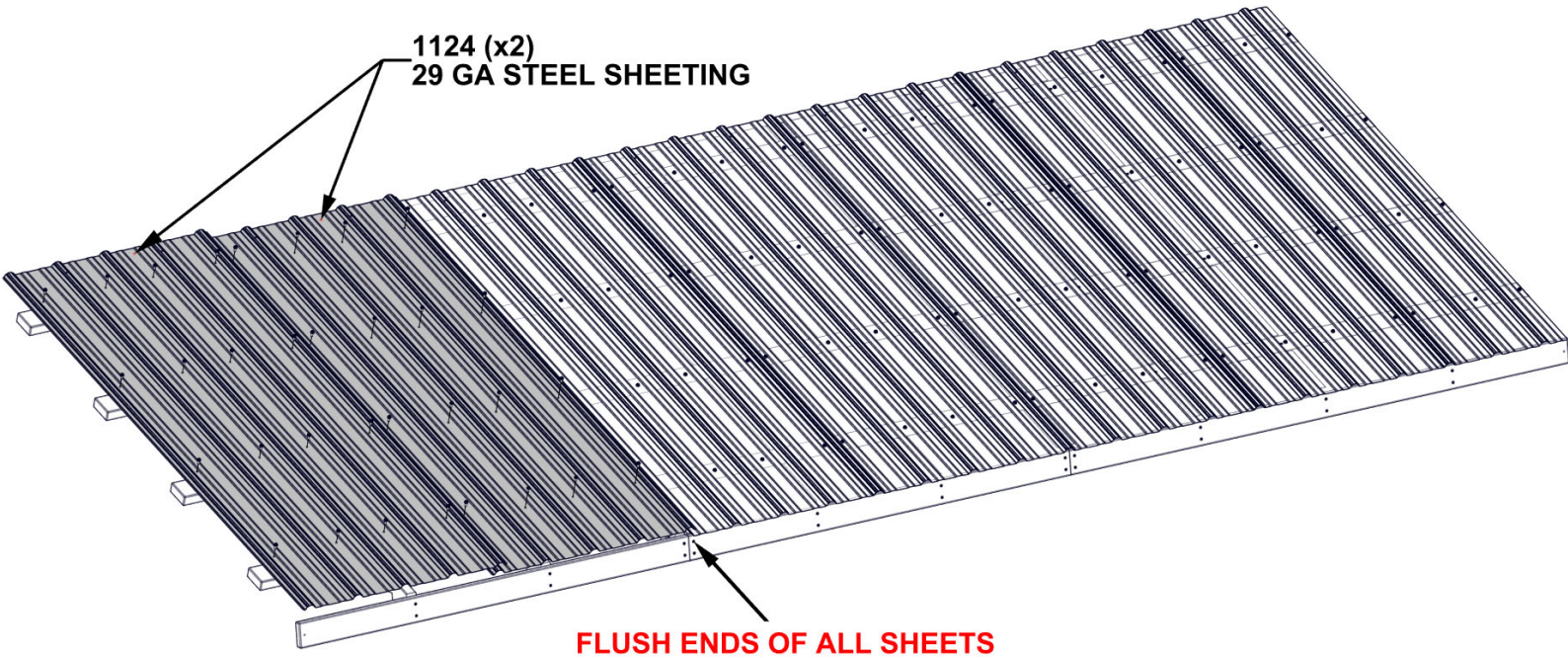
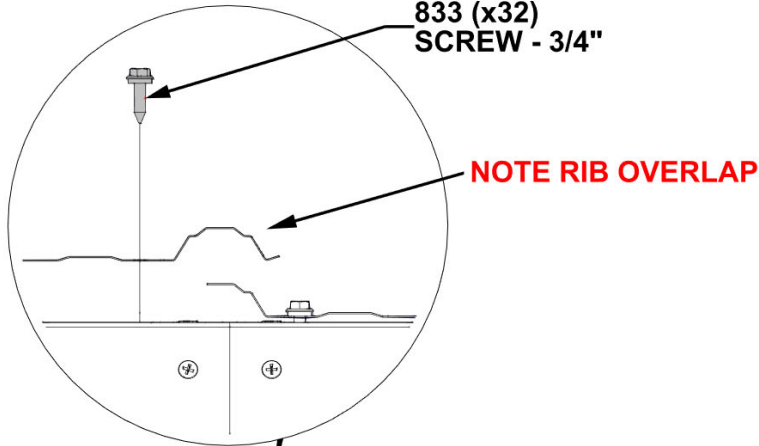

STEP 25 - ROOF PANEL ASSEMBLY

ROOF PANEL A

SEPARATE ROOF PANEL AT THIS TIME FOR EASE OF ASSEMBLING.

REMOVE HARDWARE AND SET TO THE SIDE AS IT WILL BE USED AGAIN AFTER BOTH ROOF PANELS ARE INSTALLED.

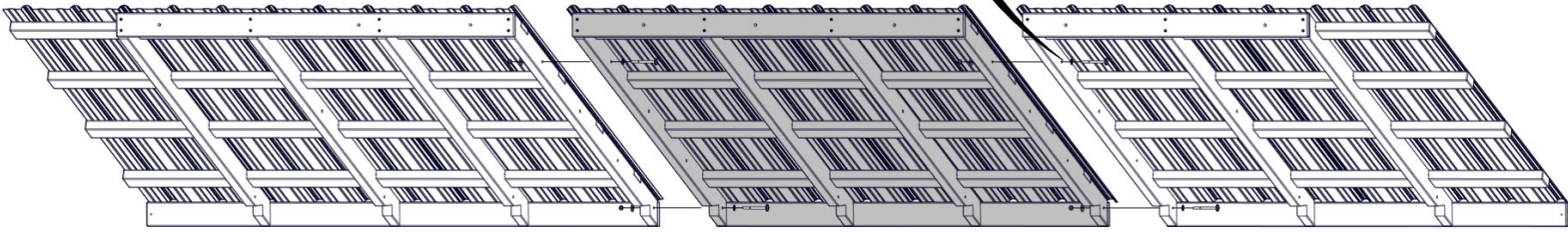
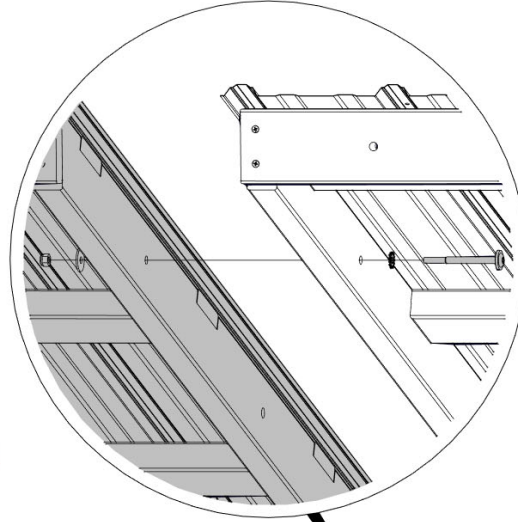

SECTION 1

SECTION 2

SECTION 3

STEP 26 - ROOF PANEL ASSEMBLY

| QTY | PART NUMBER | DESCRIPTION |
|-----|-------------|--------------------------|
| 4 | H100198 | WASHER LOCK EXT 8X19 BLK |
| 44 | H100391 | SCREW PFH 8 X 2 BLK |
| 4 | H100478 | WASHER FLAT 8X27 BLK |
| 4 | H100479 | NUT LOCK 5/16 BLK |
| 4 | H100503 | BOLT WH 5/16 X 3 1/2 BLK |

H01 | FASCIA - W4L16869
(x1) | 1"x3 3/8"x57 3/8" (24x86x1458)

H02 | FASCIA - W4L16870
(x1) | 1"x3 3/8"x58 5/8" (24x86x1490)

H03 | FASCIA - W4L16871
(x1) | 1"x3 3/8"x58 3/8" (24x86x1482)

H05 | FASCIA - W4L16873
(x1) | 1"x3 3/8"x75 1/8" (24x86x1907)

H06 | FASCIA - W4L16874
(x1) | 1"x3 3/8"x41 7/8" (24x86x1064)

H07 | FASCIA - W4L16875
(x1) | 1"x3 3/8"x57 3/8" (24x86x1458)

E01 | RAFTER - W4L16858
(x4) | 1 3/8"x3 3/8"x76 3/8" (36x86x1941)

E05 | RAFTER - W4L16862
(x4) | 1 3/8"x3 3/8"x76 3/8" (36x86x1941)

E08 | RAFTER - W4L16865
(x3) | 1 3/8"x3 3/8"x76 3/8" (36x86x1941)

ROOF PANEL B

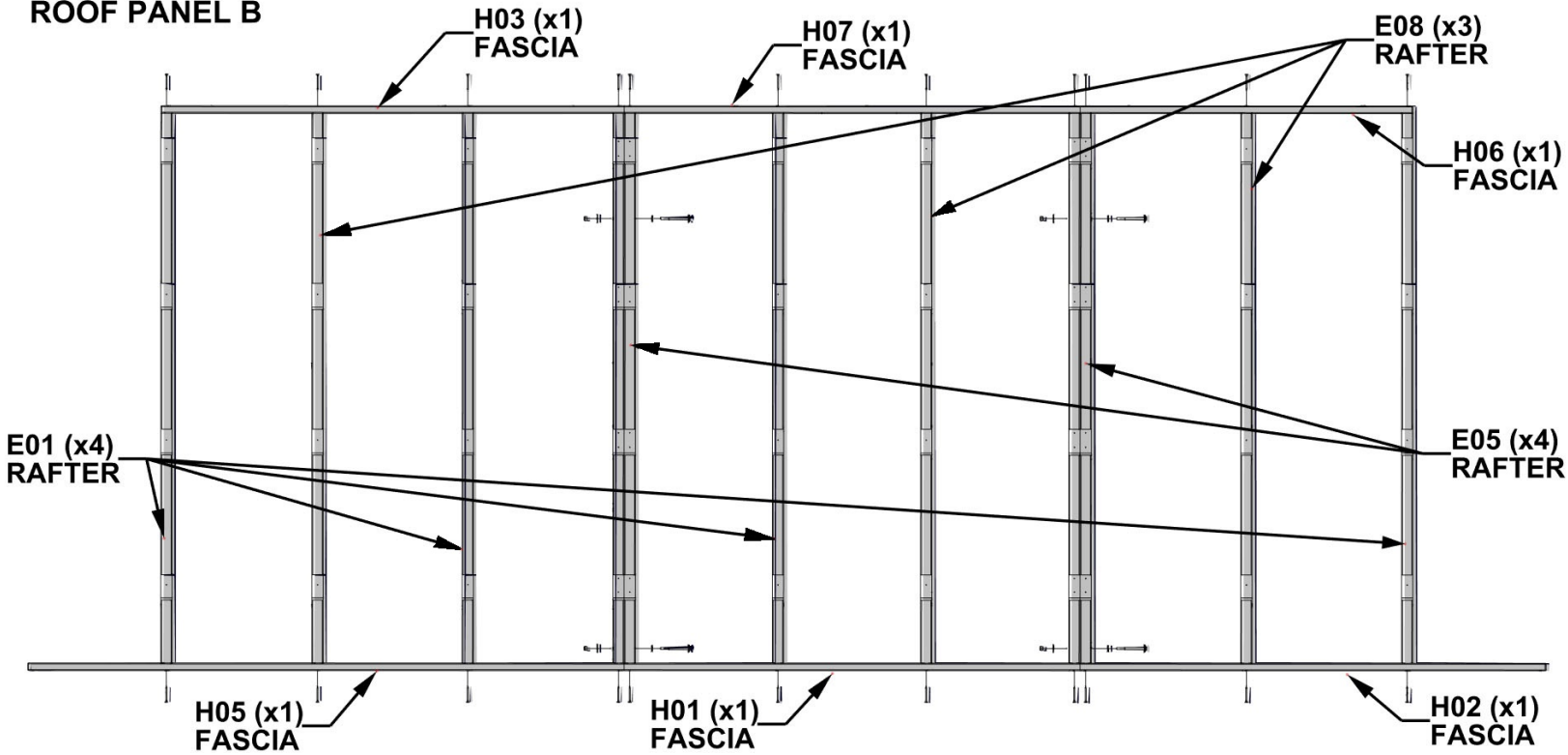

ENSURE ALL RAFTERS ARE PLACED CORRECTLY.

ENSURE H07 IS ORIENTED CORRECTLY. CHECK MEASUREMENTS FROM BOLT HOLE TO END OF BOARD AND ORIENT AS SHOWN.

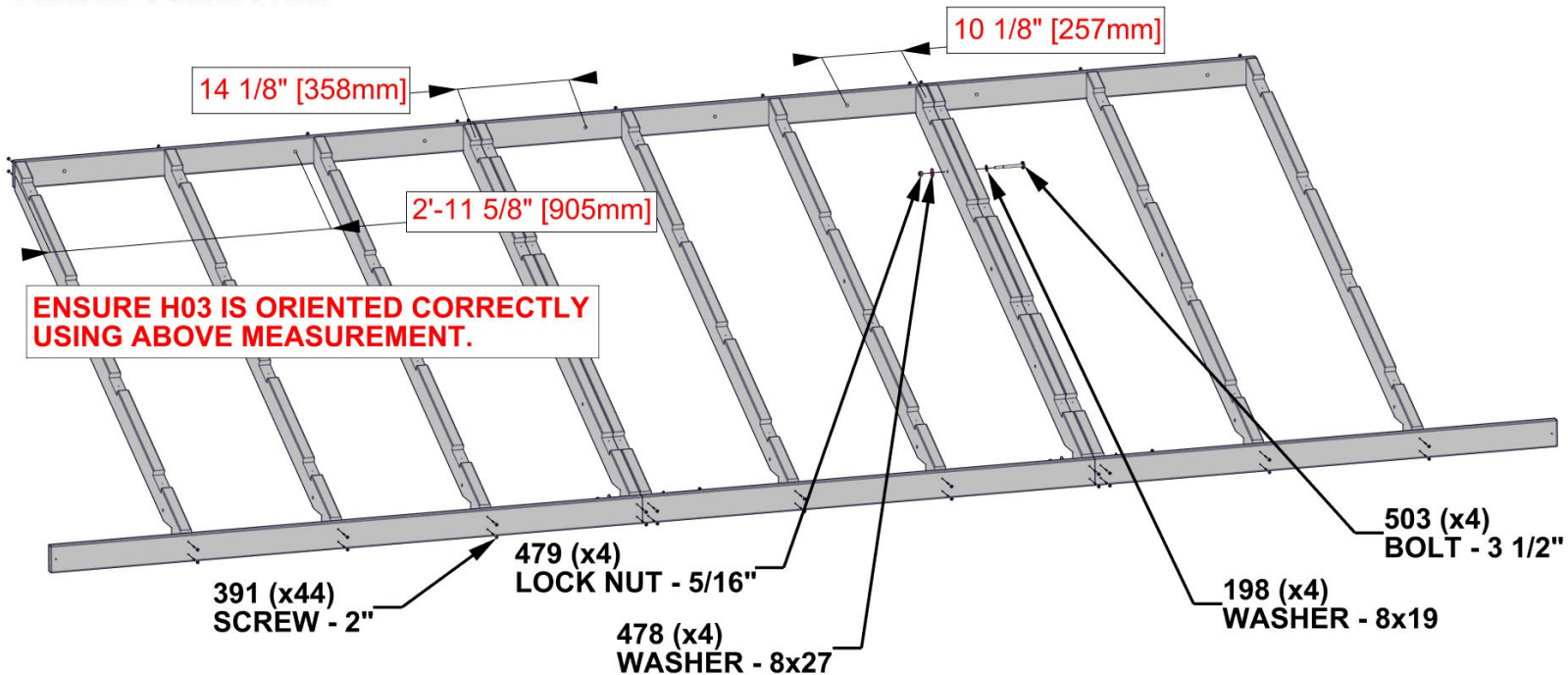

ENSURE H03 IS ORIENTED CORRECTLY USING ABOVE MEASUREMENT.

STEP 27A - ROOF PANEL ASSEMBLY

| QTY | PART NUMBER | DESCRIPTION |
|-----|-------------|---------------------|
| 60 | H100391 | SCREW PFH 8 X 2 BLK |



E03 | SHEATHING BOARD - W4L16860
(x4) | 1 3/8"x5 1/4"x75 1/8" (36x134x1907)

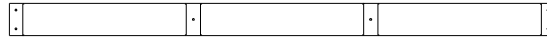

E04 | SHEATHING BOARD - W4L16861
(x4) | 1 3/8"x3 3/8"x57 3/8" (36x86x1458)

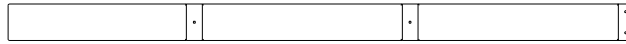

E07 | SHEATHING BOARD - W4L16864
(x4) | 1 3/8"x3 3/8"x58 5/8" (36x86x1490)

ROOF PANEL B

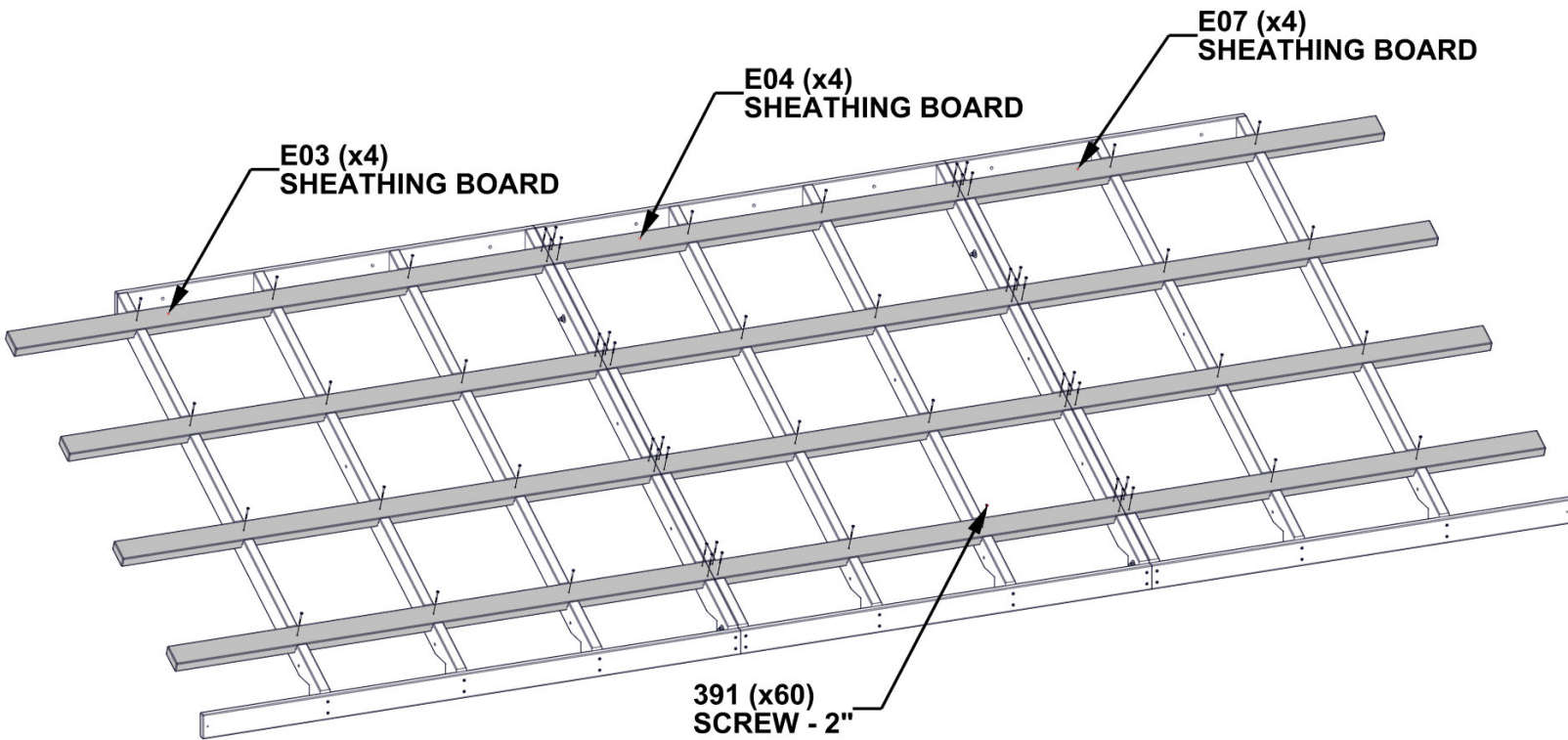

STEP 27B - ROOF PANEL ASSEMBLY

ROOF PANEL B

TIP: LOOSEN HARDWARE TO ADJUST FOR SQUARING IF NEEDED

CRITICAL:

- SQUARE UNIT BEFORE PROCEEDING TO NEXT STEPS.
- THE BELOW DIMENSIONS ARE CRITICAL TO THE FINAL ROOF ASSEMBLY.
- MEASUREMENTS SHOULD BE HELD WITHIN +/- 1/4".
- MEASUREMENTS OUTSIDE OF TOLERANCE WILL LEAD TO THE INABILITY TO ASSEMBLY THE ROOF.

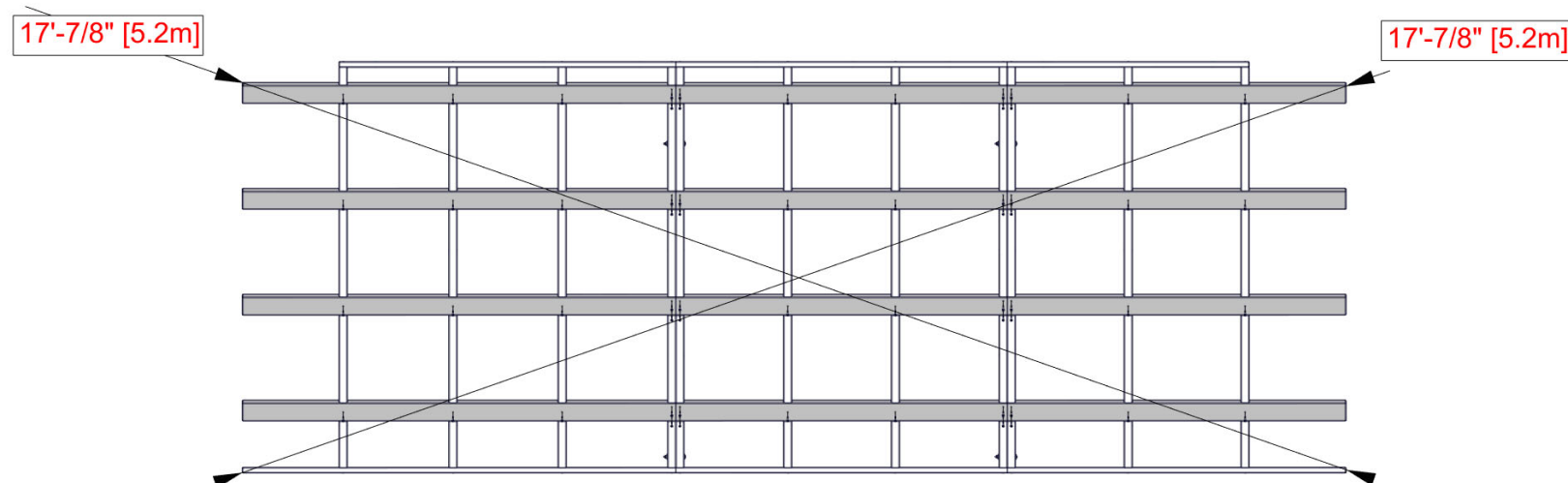

STEP 28 - ROOF PANEL ASSEMBLY

ROOF PANEL B

USE THIS PAGE TO FAMILIARIZE YOURSELF WITH THE ROOF PANEL AND ASSIST YOU IN STEPS 29-31.

TIPS:

- REMOVE PROTECTIVE BLUE FILM
- START AT THE END INDICATED AND ASSEMBLE IN THE DIRECTION OF THE ARROW

GLOVES SHOULD BE WORN WHEN HANDLING ROOF PANELS: EDGES ARE SHARP.

THE PRE-DRILLED HOLES ON EACH PANEL SHOULD ALWAYS BE POSITIONED ON THE RIDGE SIDE.

RIDGE

ROOF PANEL STEPS 29-31

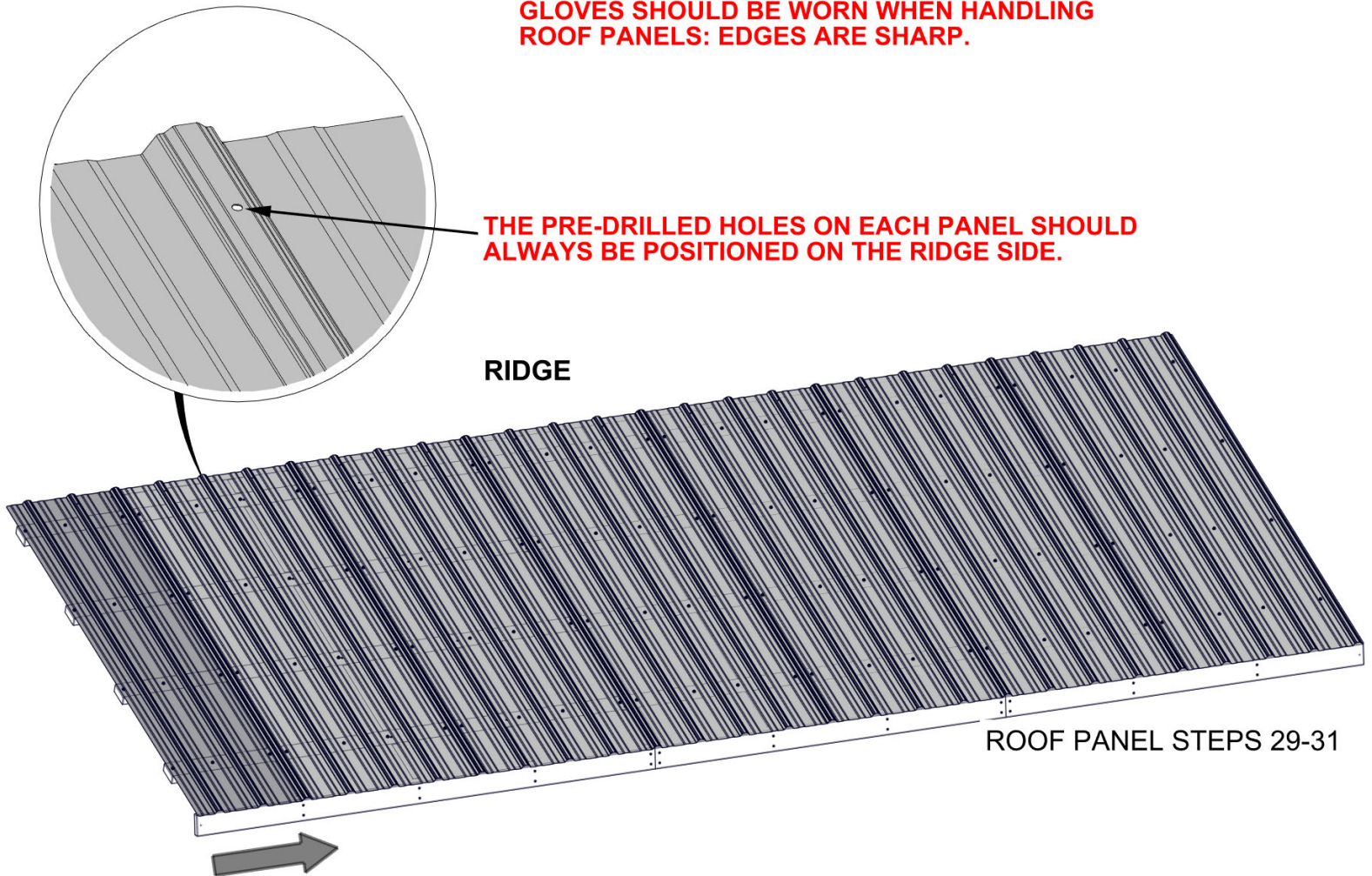

STEP 29 - ROOF PANEL ASSEMBLY

| QTY | PART NUMBER | DESCRIPTION |
|-----|-------------|----------------------------|
| 44 | H100833 | SCREW WOODGRIP 10-16 x 3/4 |

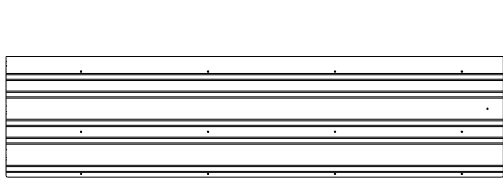

A4M01370 (x1) | 29 GA STEEL SHEETING

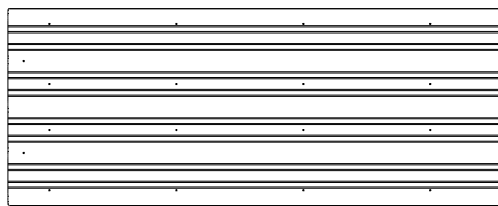

A4M01124 (x1) | 29 GA STEEL SHEETING



A4M01718 (x1) | 29 GA STEEL SHEETING

ROOF PANEL B

NOTE RIB OVERLAP

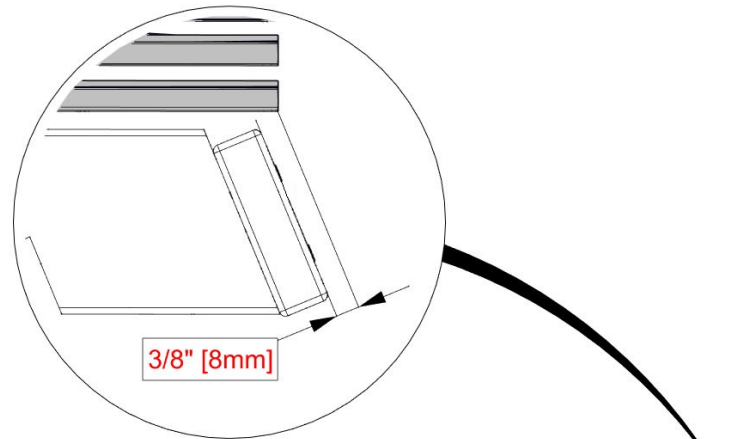
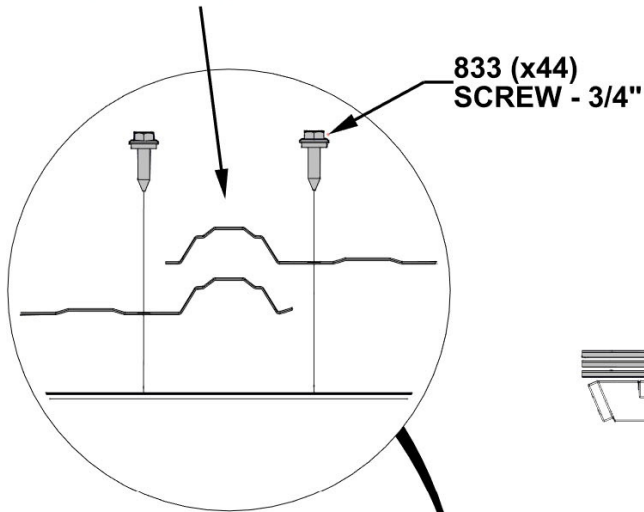

MAKE SURE YOUR ROOF PANEL IS SQUARE BEFORE MOVING ON.

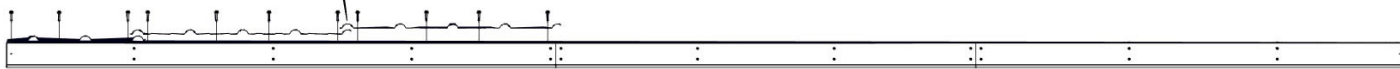

1370 (x1)
29 GA STEEL SHEETING

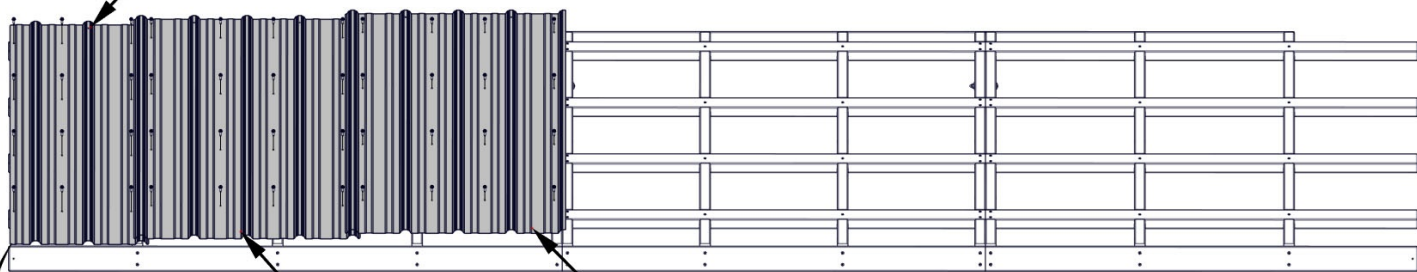

1718 (x1)
29 GA STEEL SHEETING

1124 (x1)
29 GA STEEL SHEETING

ENSURE CORRECT PLACEMENT OF 1718 STEEL SHEETING.

HOLD SHEETING INSIDE OF FRAME MEASURING FROM RIB AS SHOWN.

2 7/8" [72mm]

STEP 30 - ROOF PANEL ASSEMBLY

| QTY | PART NUMBER | DESCRIPTION |
|-----|-------------|----------------------------|
| 32 | H100833 | SCREW WOODGRIP 10-16 x 3/4 |



A4M01124 (x1) | 29 GA STEEL SHEETING

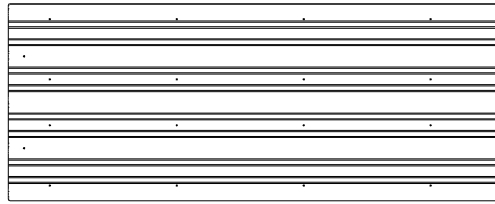

A4M01718 (x1) | 29 GA STEEL SHEETING

ROOF PANEL B

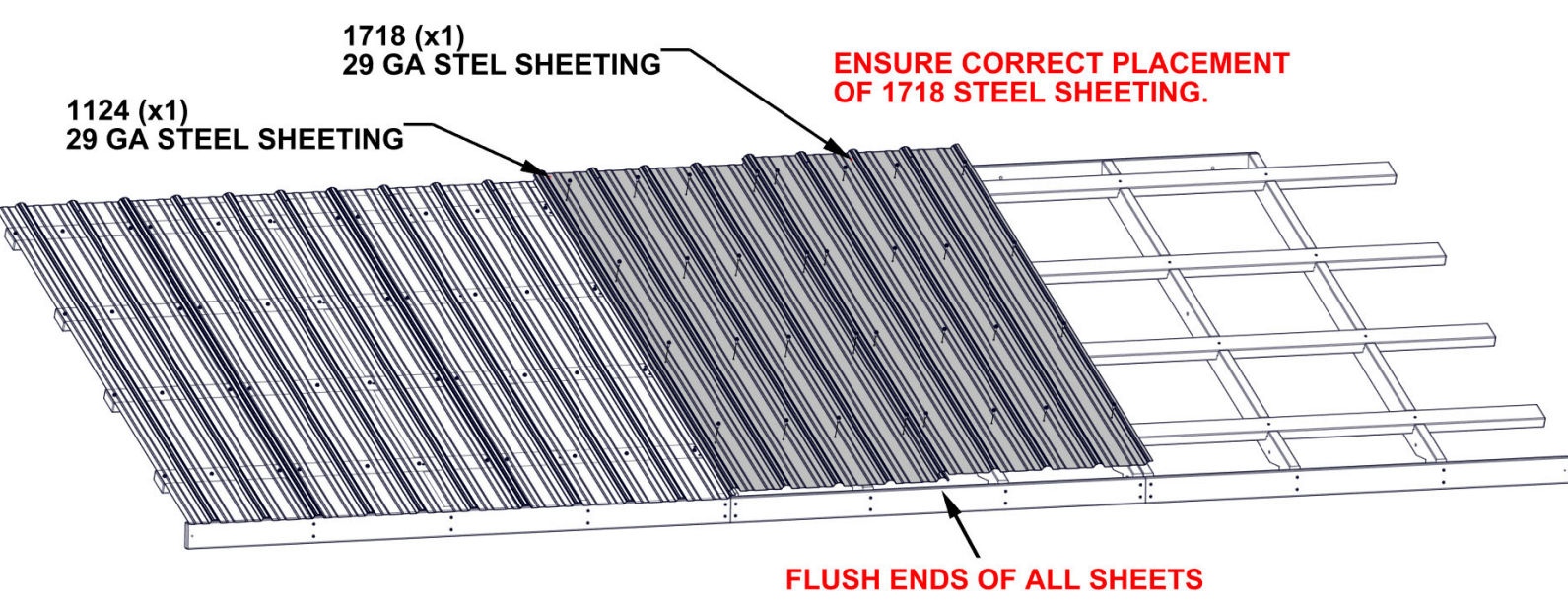
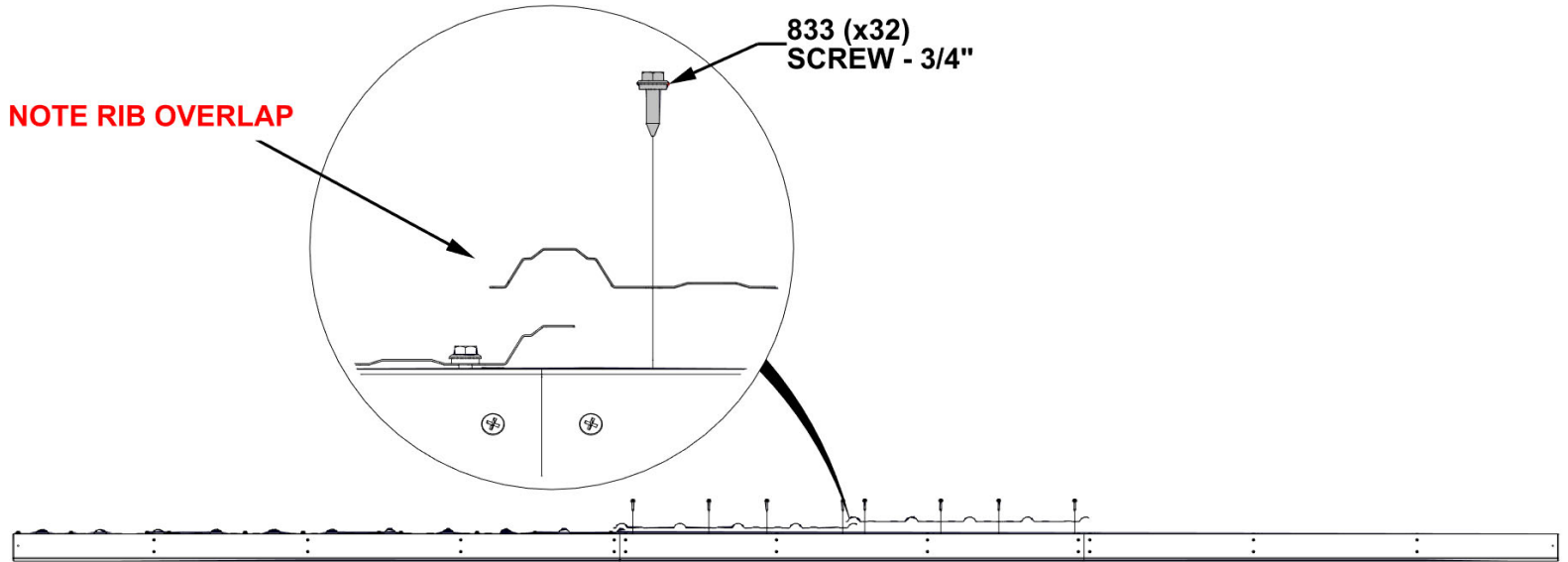

STEP 31 - ROOF PANEL ASSEMBLY

| QTY | PART NUMBER | DESCRIPTION |
|-----|-------------|----------------------------|
| 32 | H100833 | SCREW WOODGRIP 10-16 x 3/4 |

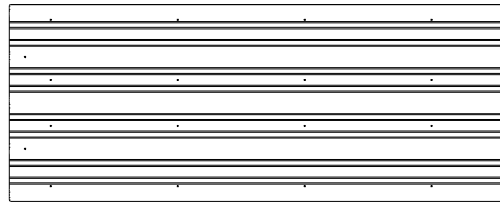

A4M01124
(x2) | 29 GA STEEL SHEETING

ROOF PANEL B

NOTE RIB OVERLAP

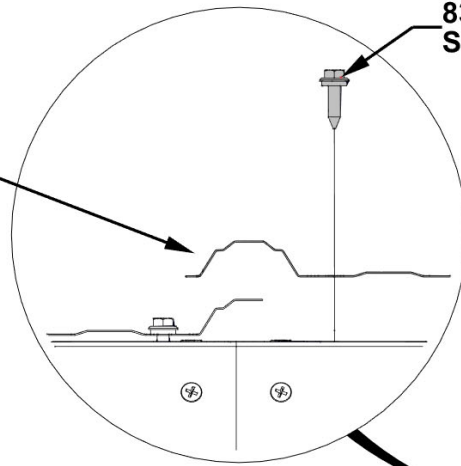

833 (x32)
SCREW - 3/4"

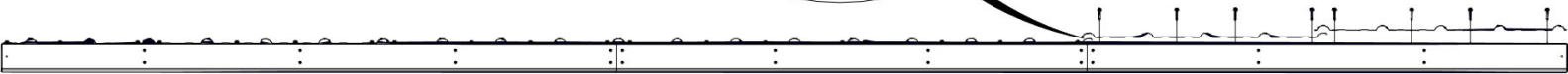

1124 (x2)
29 GA STEEL SHEETING



FLUSH ENDS OF ALL SHEETS

STEP 32 - ROOF PANEL ASSEMBLY

ROOF PANEL B

SEPARATE ROOF PANEL AT THIS TIME FOR EASE OF ASSEMBLING.

REMOVE HARDWARE AND SET TO THE SIDE AS IT WILL BE USED AGAIN AFTER BOTH ROOF PANELS ARE INSTALLED.

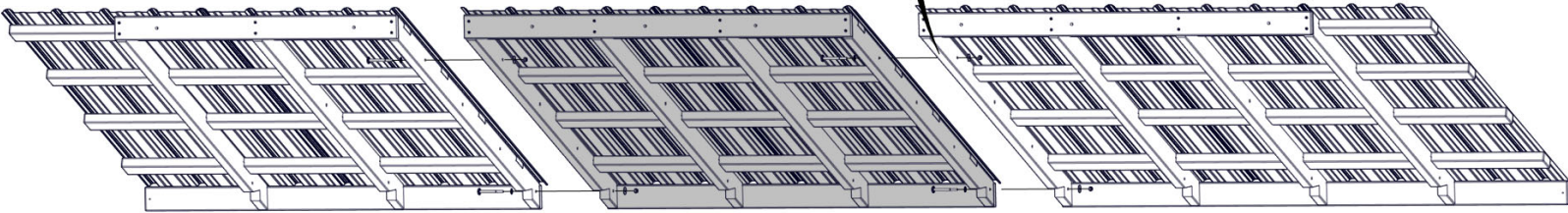
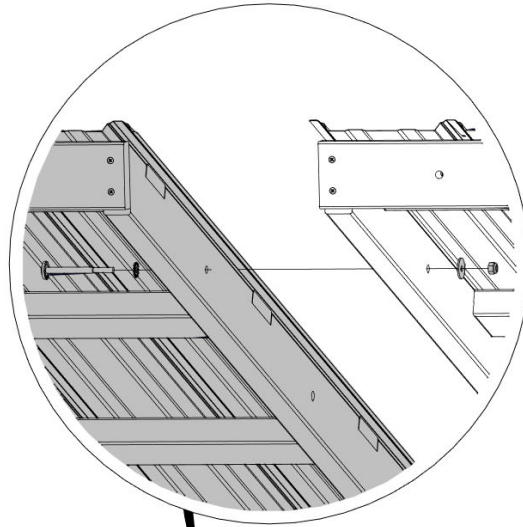

SECTION 3

SECTION 2

SECTION 1

STEP 33 - ROOF ASSEMBLY

| QTY | PART NUMBER | DESCRIPTION |
|-----|-------------|--------------------------|
| 3 | H100198 | WASHER LOCK EXT 8X19 BLK |
| 3 | H100378 | BOLT WH 5/16 X 1 3/4 BLK |
| 1 | H100391 | SCREW PFH 8 X 2 BLK |

INSTALL ROOF PANEL A, SECTION 1

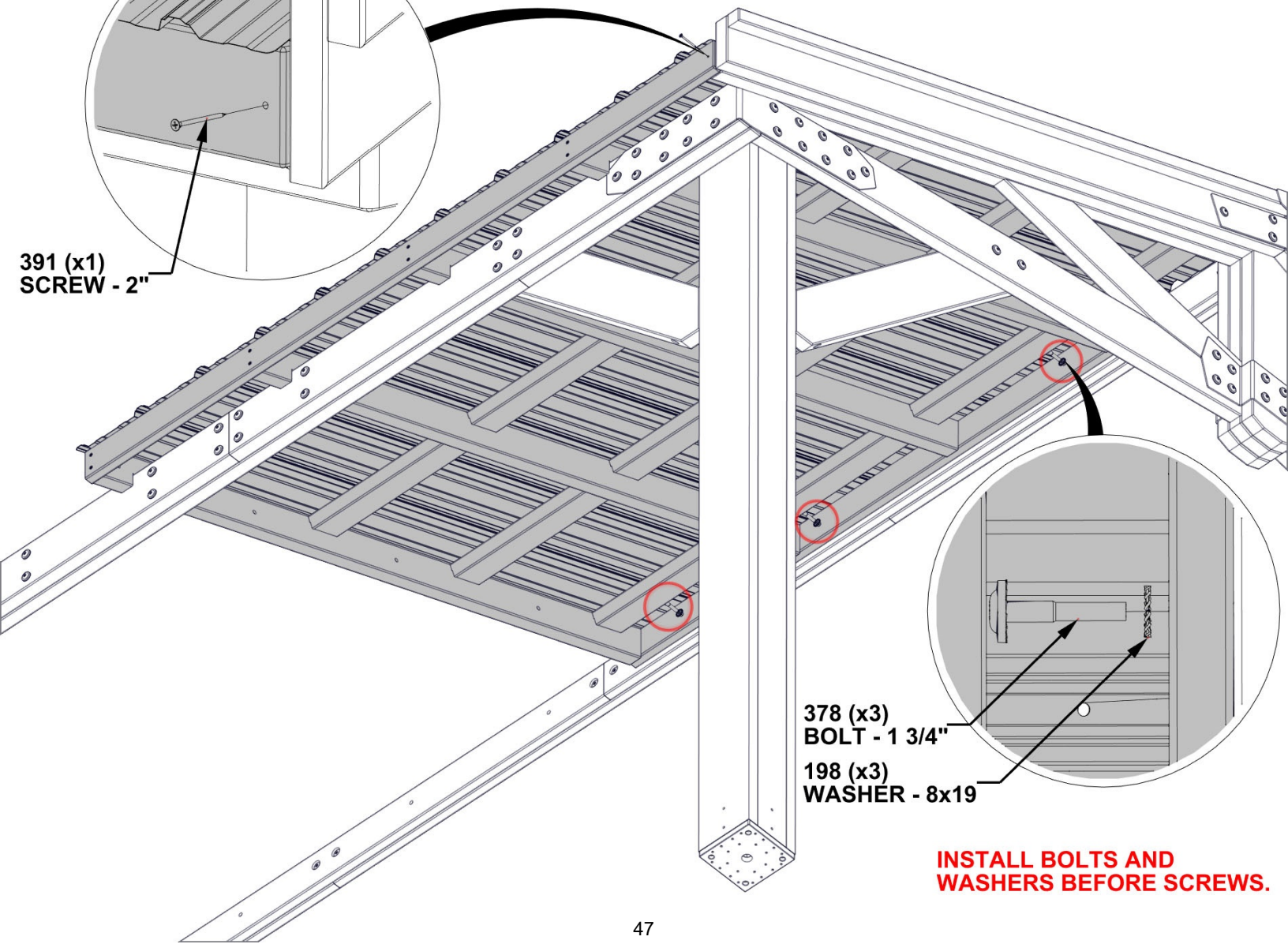
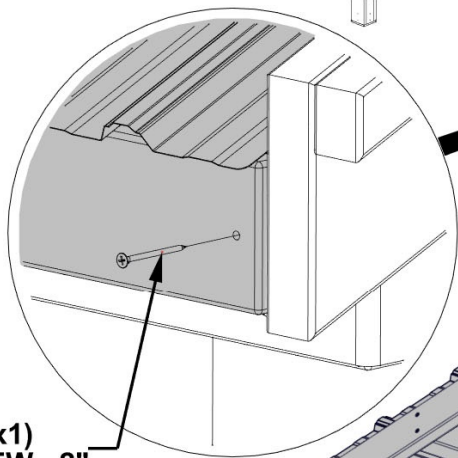
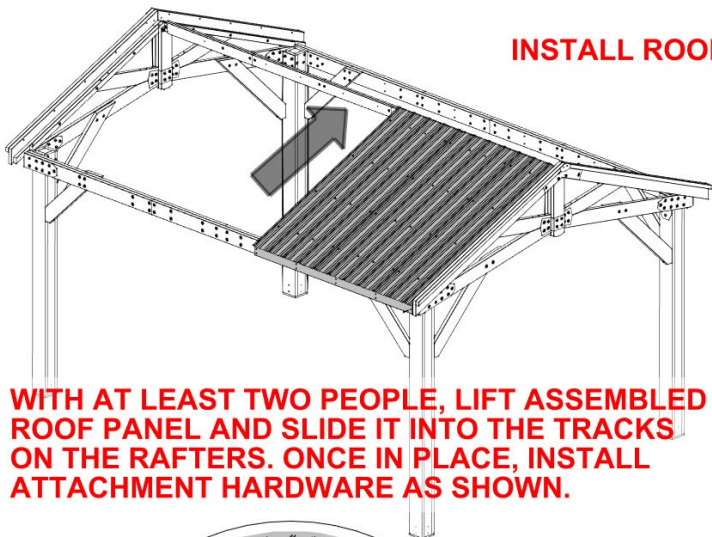

INSTALL BOLTS AND WASHERS BEFORE SCREWS.

STEP 34 - ROOF ASSEMBLY

| QTY | PART NUMBER | DESCRIPTION |
|-----|-------------|--------------------------|
| 3 | H100198 | WASHER LOCK EXT 8X19 BLK |
| 3 | H100378 | BOLT WH 5/16 X 1 3/4 BLK |
| 1 | H100391 | SCREW PFH 8 X 2 BLK |

INSTALL ROOF PANEL B, SECTION 1

INSTALL BOLTS AND WASHERS BEFORE SCREWS.

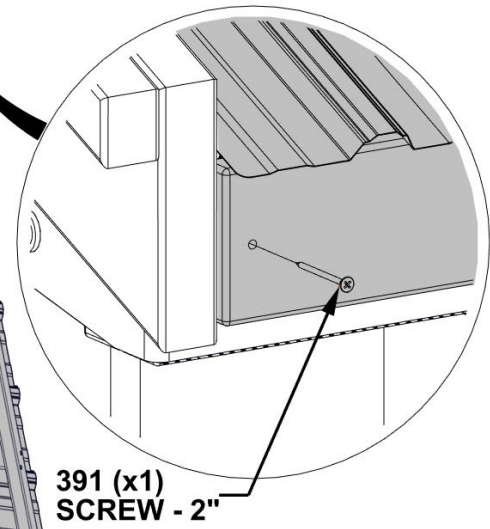
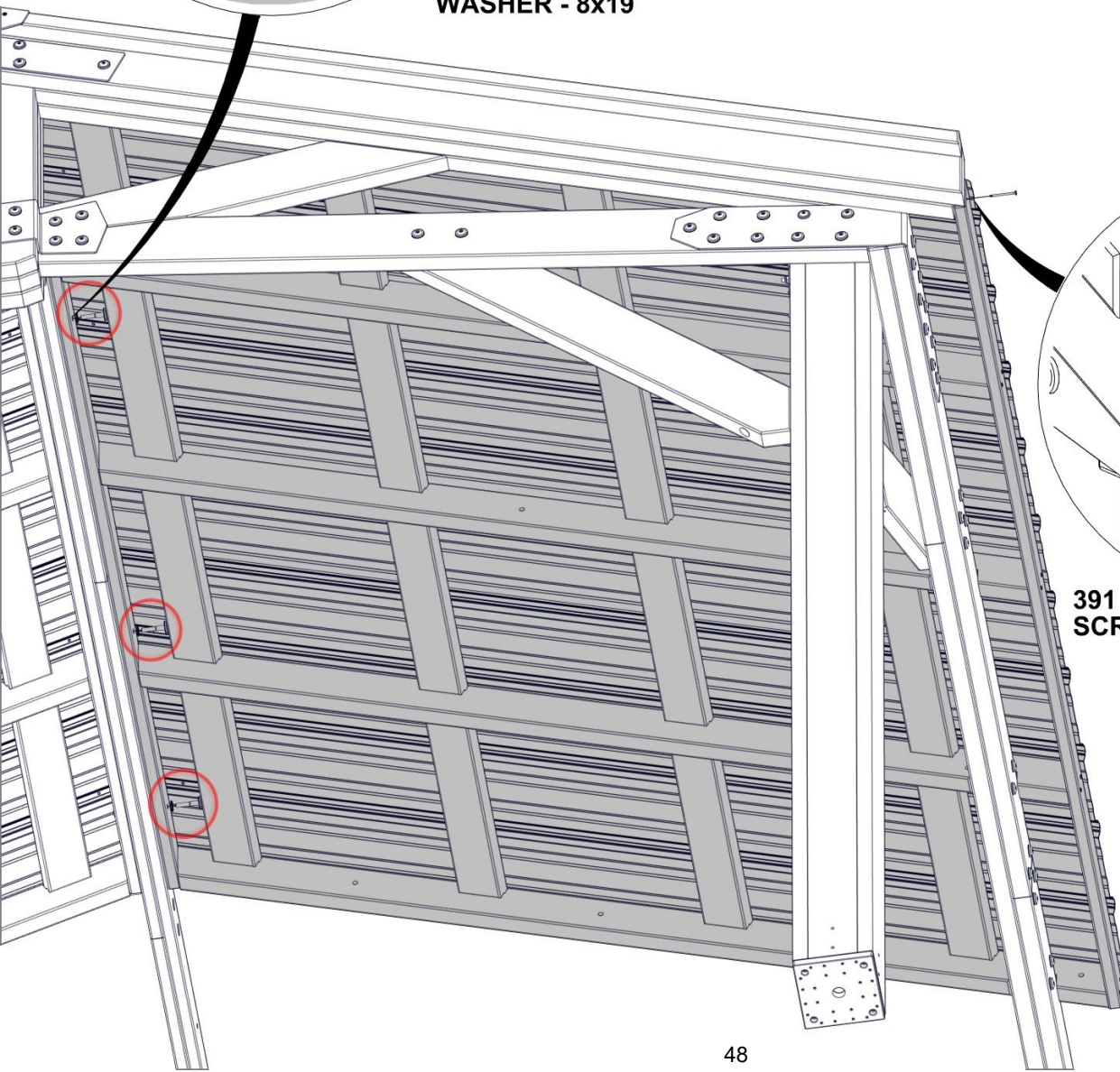
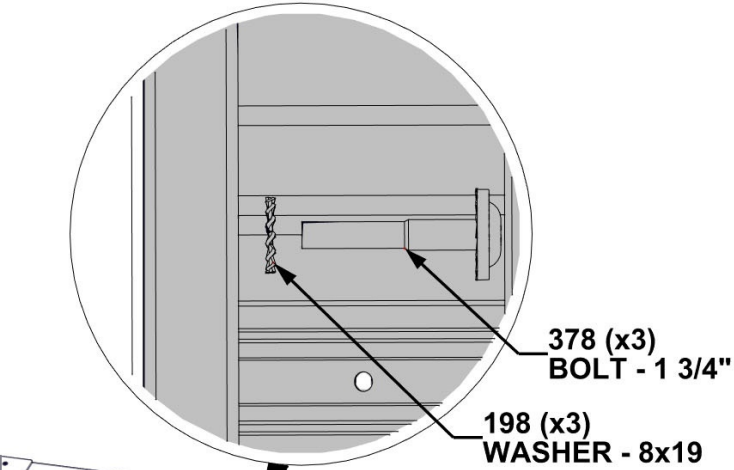
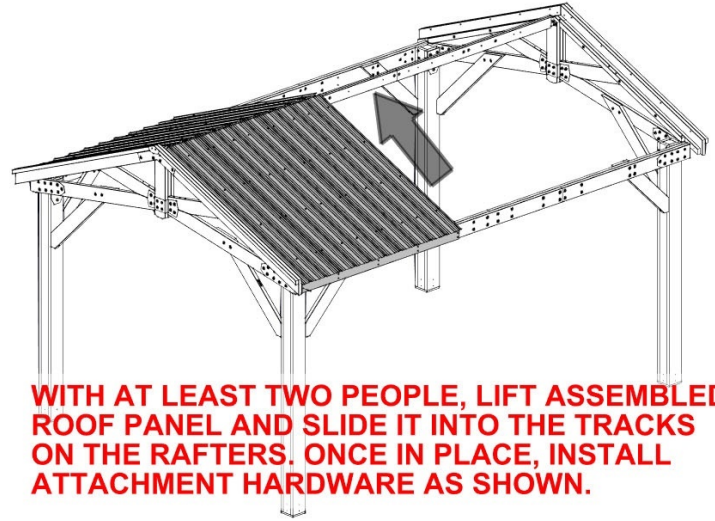

STEP 35 - ROOF ASSEMBLY

| QTY | PART NUMBER | DESCRIPTION |
|-----|-------------|--------------------------|
| 2 | H100198 | WASHER LOCK EXT 8X19 BLK |
| 2 | H100478 | WASHER FLAT 8X27 BLK |
| 2 | H100479 | NUT LOCK 5/16 BLK |
| 2 | H100480 | BOLT WH 5/16 X 4 3/4 BLK |

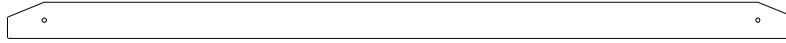

E06 | ACCESSORY TRUSS - W4L16863
 (x2) | 1 3/8"x3 3/8"x73 13/16" (36x86x1875)

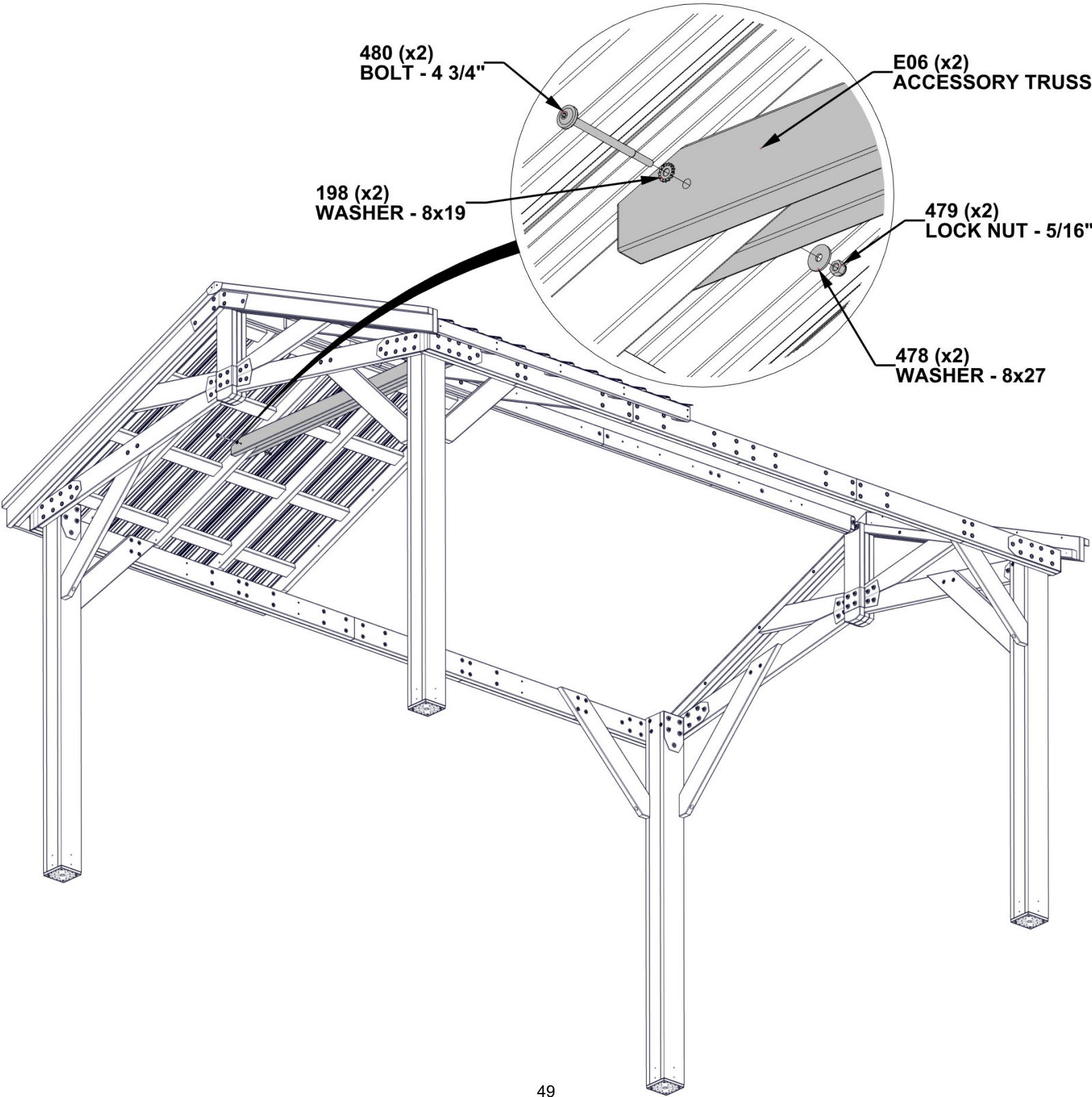

STEP 36 - ROOF ASSEMBLY

| QTY | PART NUMBER | DESCRIPTION |
|-----|-------------|--------------------------|
| 6 | H100198 | WASHER LOCK EXT 8X19 BLK |
| 3 | H100378 | BOLT WH 5/16 X 1 3/4 BLK |
| 3 | H100478 | WASHER FLAT 8X27 BLK |
| 3 | H100479 | NUT LOCK 5/16 BLK |
| 3 | H100503 | BOLT WH 5/16 X 3 1/2 BLK |

INSTALL ROOF PANEL A, SECTION 2

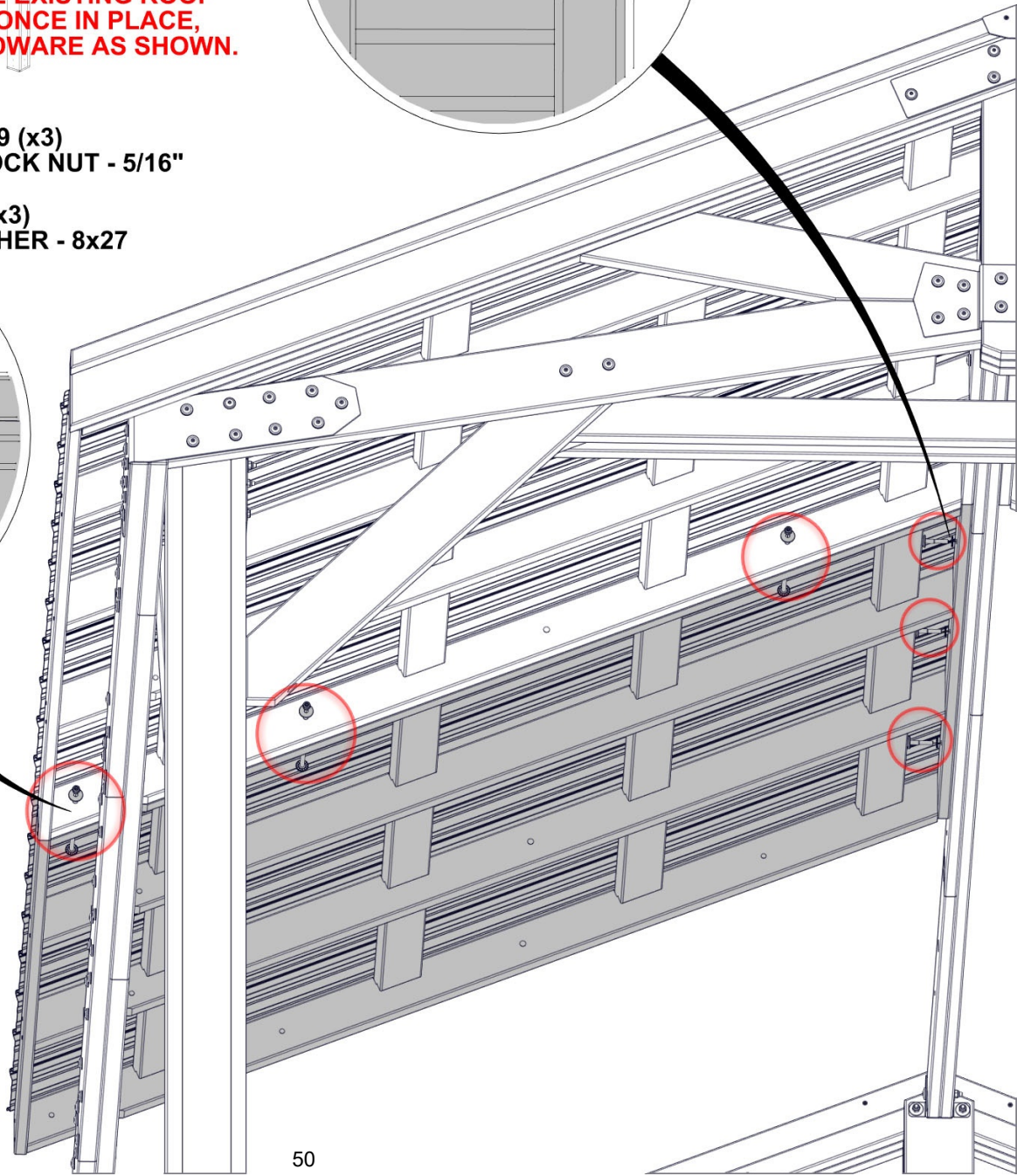
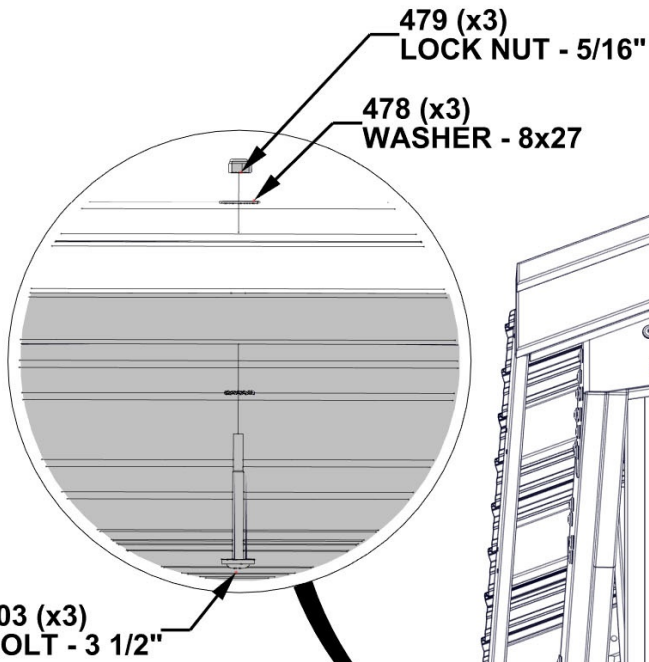
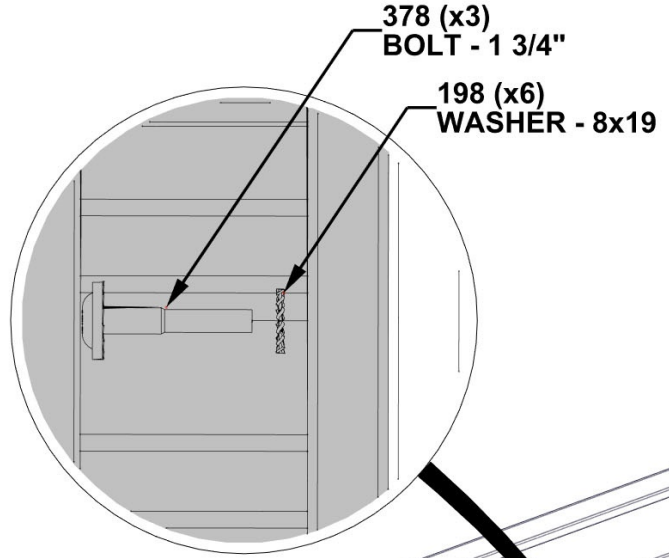

STEP 37 - ROOF ASSEMBLY

| QTY | PART NUMBER | DESCRIPTION |
|-----|-------------|--------------------------|
| 6 | H100198 | WASHER LOCK EXT 8X19 BLK |
| 3 | H100378 | BOLT WH 5/16 X 1 3/4 BLK |
| 3 | H100478 | WASHER FLAT 8X27 BLK |
| 3 | H100479 | NUT LOCK 5/16 BLK |
| 3 | H100503 | BOLT WH 5/16 X 3 1/2 BLK |

INSTALL ROOF PANEL B, SECTION 2



WITH AT LEAST TWO PEOPLE, LIFT ASSEMBLED ROOF PANEL AND SLIDE IT INTO THE TRACKS ON THE RAFTERS. YOU MAY HAVE TO LIFT THE CORNER OF THE EXISTING ROOF PANEL TO GET IT STARTED. ONCE IN PLACE, INSTALL ATTACHMENT HARDWARE AS SHOWN.

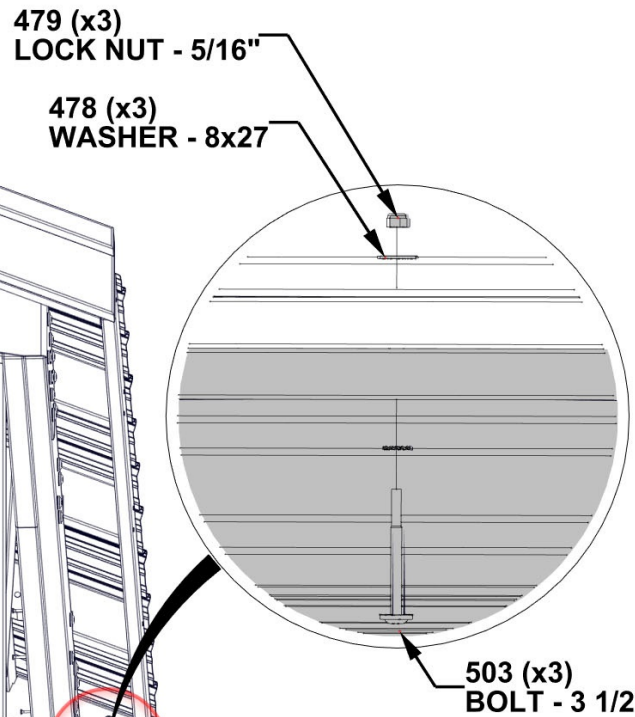
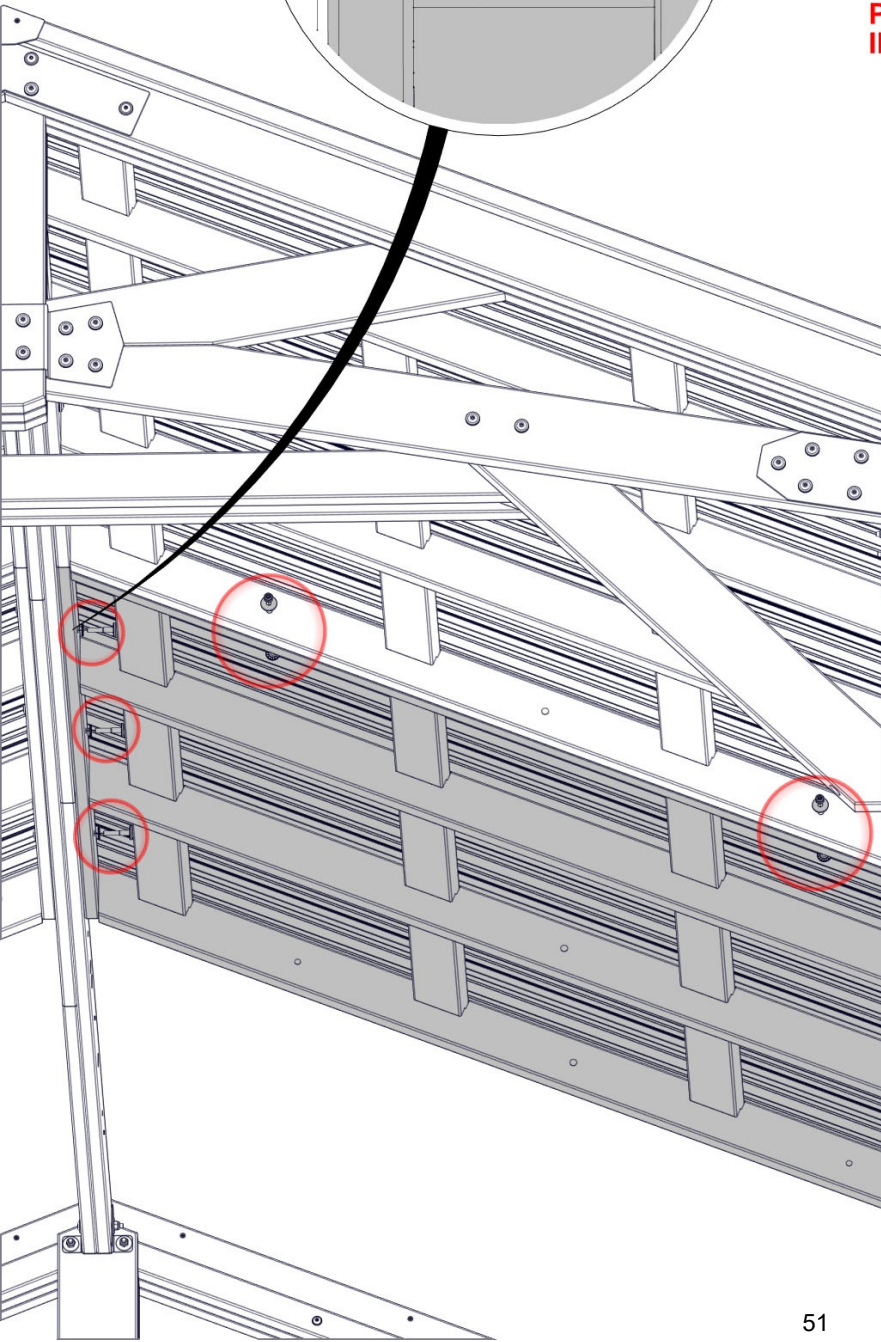
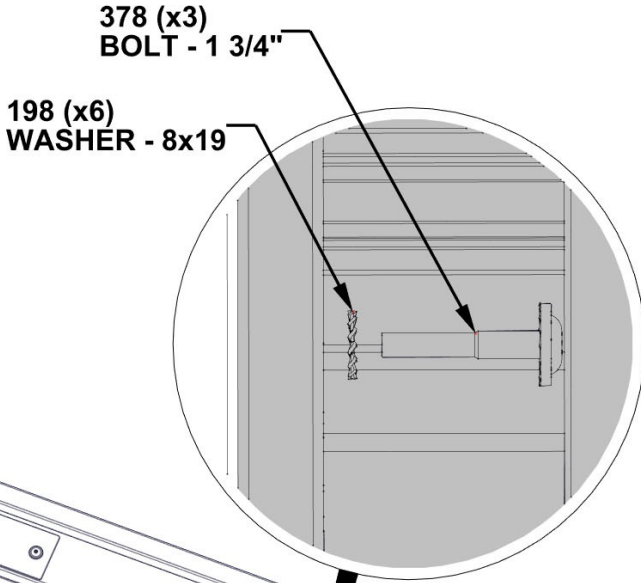

STEP 38 - ROOF ASSEMBLY

| QTY | PART NUMBER | DESCRIPTION |
|-----|-------------|--------------------------|
| 4 | H100198 | WASHER LOCK EXT 8X19 BLK |
| 4 | H100478 | WASHER FLAT 8X27 BLK |
| 4 | H100479 | NUT LOCK 5/16 BLK |
| 2 | H100480 | BOLT WH 5/16 X 4 3/4 BLK |
| 2 | H100976 | BOLT WH 5/16 X 6 1/4 BLK |



E06 | ACCESSORY TRUSS - W4L16863
 (x4) 1 3/8"x3 3/8"x73 13/16" (36x86x1875)

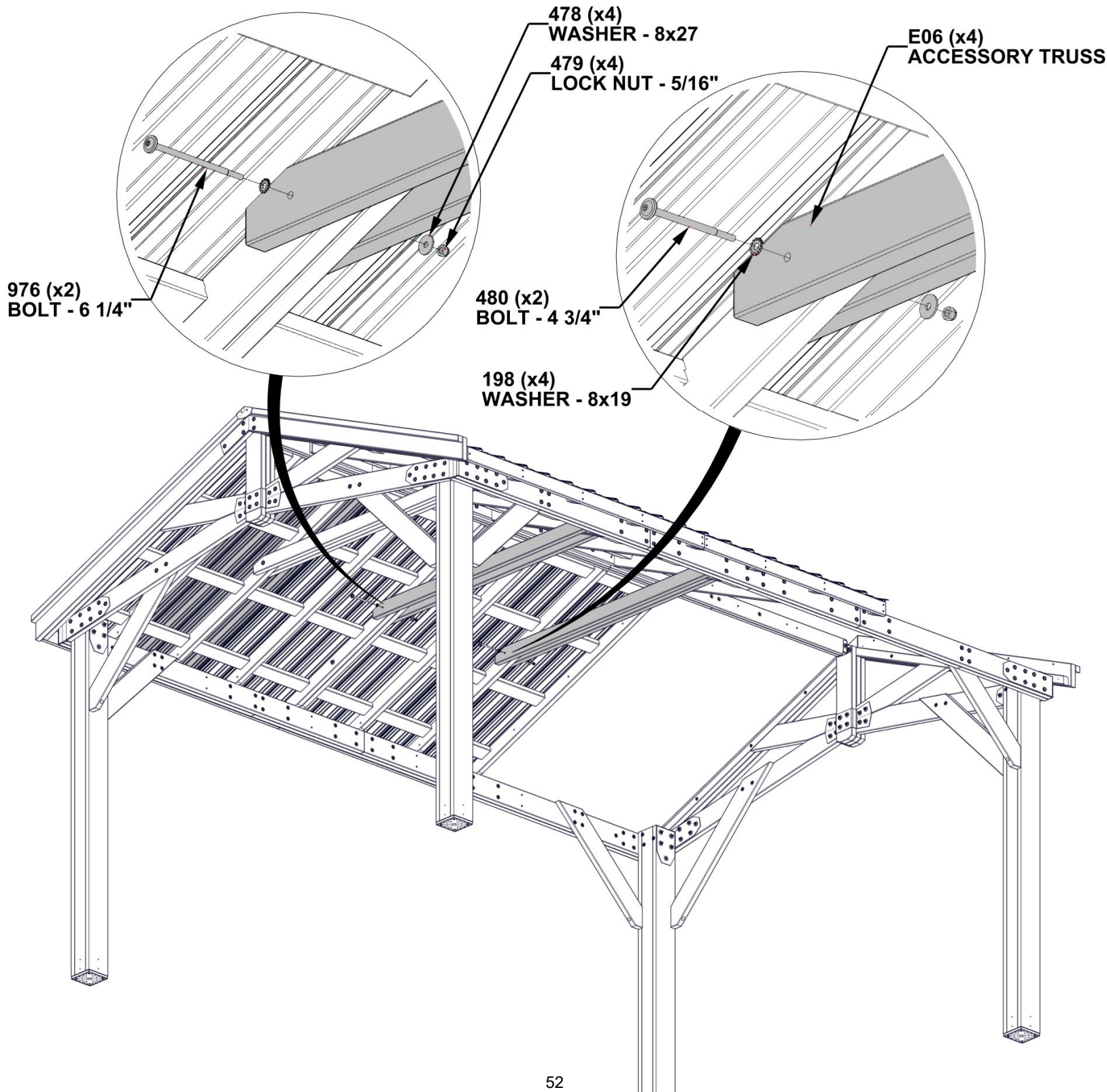

STEP 39 - ROOF ASSEMBLY

| QTY | PART NUMBER | DESCRIPTION |
|-----|-------------|--------------------------|
| 6 | H100198 | WASHER LOCK EXT 8X19 BLK |
| 2 | H100378 | BOLT WH 5/16 X 1 3/4 BLK |
| 1 | H100391 | SCREW PFH 8 X 2 BLK |
| 4 | H100478 | WASHER FLAT 8X27 BLK |
| 4 | H100479 | NUT LOCK 5/16 BLK |
| 4 | H100503 | BOLT WH 5/16 X 3 1/2 BLK |

INSTALL ROOF PANEL A, SECTION 3

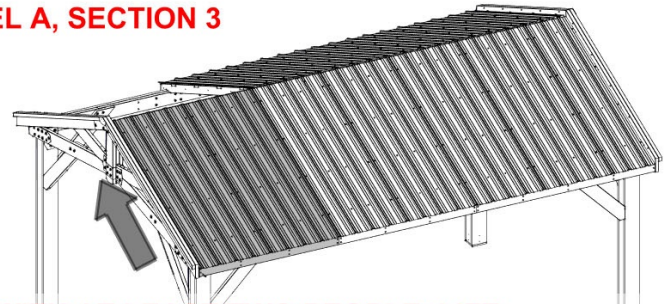

WITH AT LEAST TWO PEOPLE, LIFT ASSEMBLED ROOF PANEL AND SLIDE IT INTO THE TRACKS ON THE RAFTERS. YOU MAY HAVE TO LIFT THE CORNER OF THE EXISTING ROOF PANEL TO GET IT STARTED. ONCE IN PLACE, INSTALL ATTACHMENT HARDWARE AS SHOWN.

INSTALL BOLTS AND WASHERS BEFORE SCREWS.

198 (x6)
WASHER - 8x19

378 (x2)
BOLT - 1 3/4"

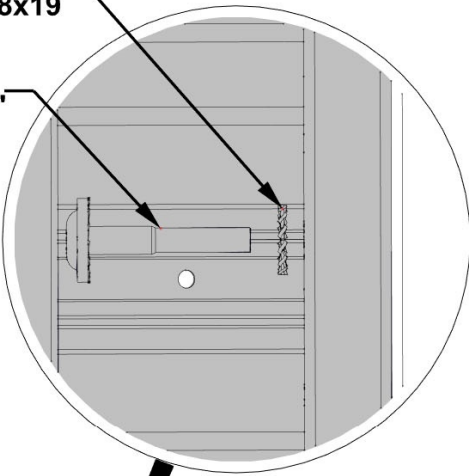

391 (x1)
SCREW - 2"

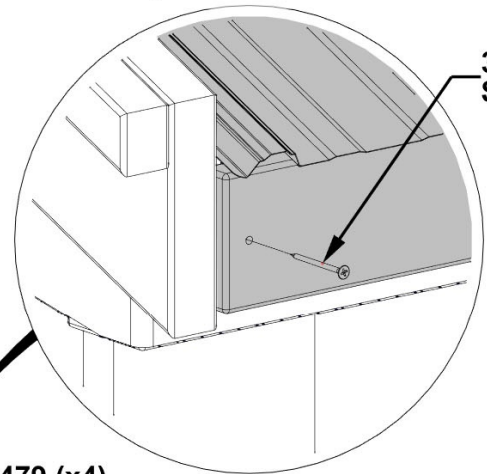

479 (x4)
LOCK NUT - 5/16"

478 (x4)
WASHER - 8x27

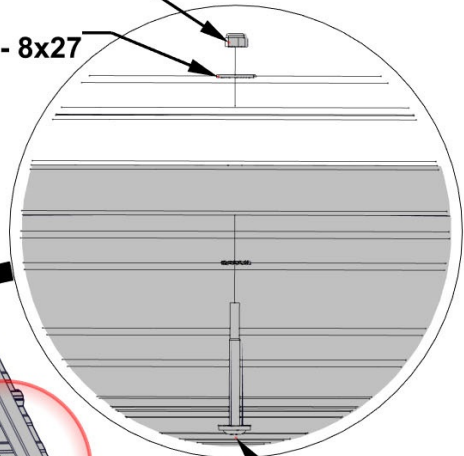

503 (x4)
BOLT - 3 1/2"

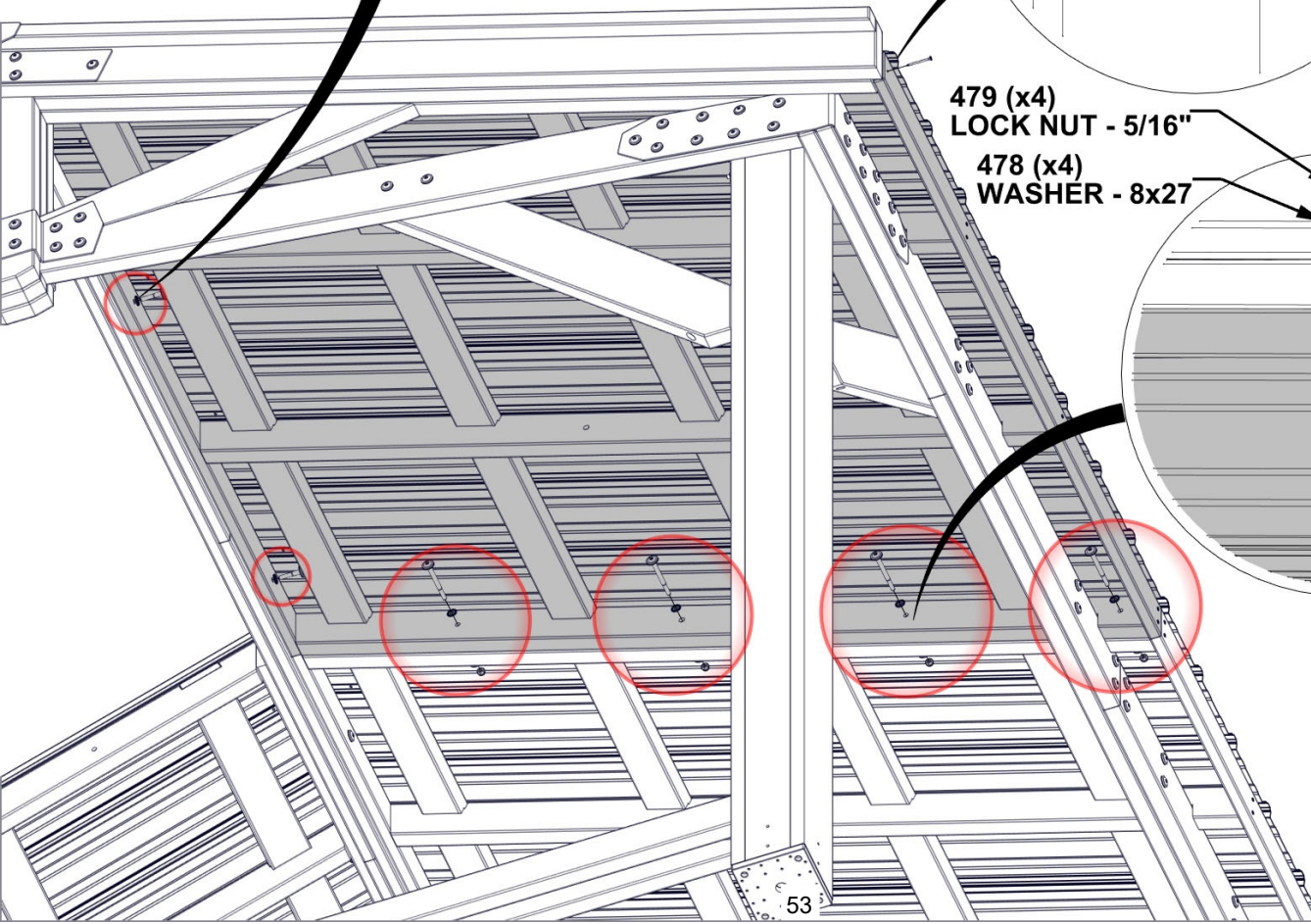

STEP 40 - ROOF ASSEMBLY

| QTY | PART NUMBER | DESCRIPTION |
|-----|-------------|--------------------------|
| 6 | H100198 | WASHER LOCK EXT 8X19 BLK |
| 2 | H100378 | BOLT WH 5/16 X 1 3/4 BLK |
| 1 | H100391 | SCREW PFH 8 X 2 BLK |
| 4 | H100478 | WASHER FLAT 8X27 BLK |
| 4 | H100479 | NUT LOCK 5/16 BLK |
| 4 | H100503 | BOLT WH 5/16 X 3 1/2 BLK |

INSTALL ROOF PANEL B, SECTION 3



378 (x2)
BOLT - 1 3/4"

198 (x6)
WASHER - 8x19

391 (x1)
SCREW - 2"

479 (x4)
LOCK NUT - 5/16"

478 (x4)
WASHER - 8x27

503 (x4)
BOLT - 3 1/2"

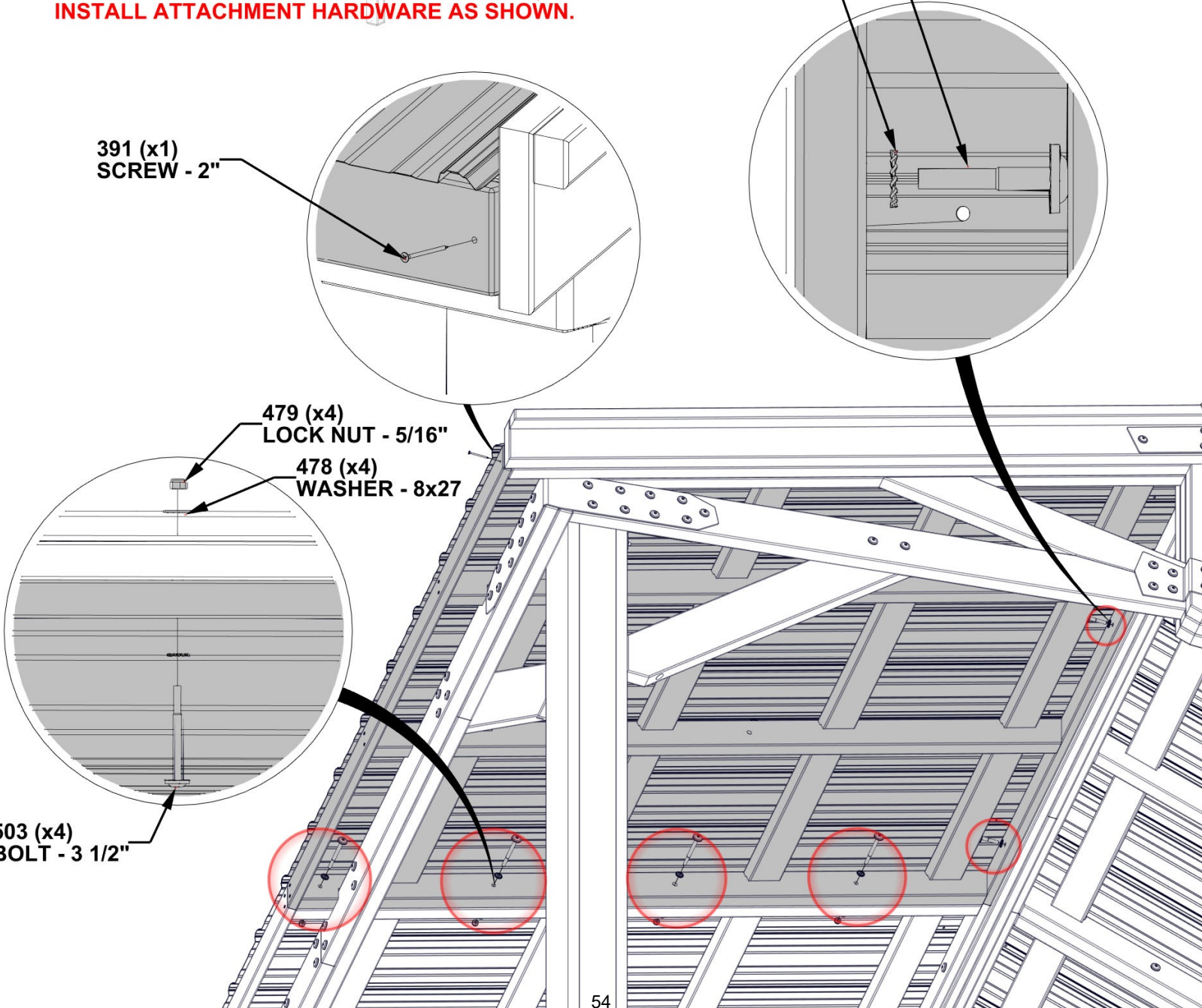

STEP 41 - ROOF ASSEMBLY

| QTY | PART NUMBER | DESCRIPTION |
|-----|-------------|--------------------------|
| 2 | H100198 | WASHER LOCK EXT 8X19 BLK |
| 2 | H100478 | WASHER FLAT 8X27 BLK |
| 2 | H100479 | NUT LOCK 5/16 BLK |
| 2 | H100480 | BOLT WH 5/16 X 4 3/4 BLK |

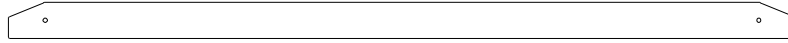

E06 | ACCESSORY TRUSS - W4L16863
 (x2) | 1 3/8"x3 3/8"x73 13/16" (36x86x1875)

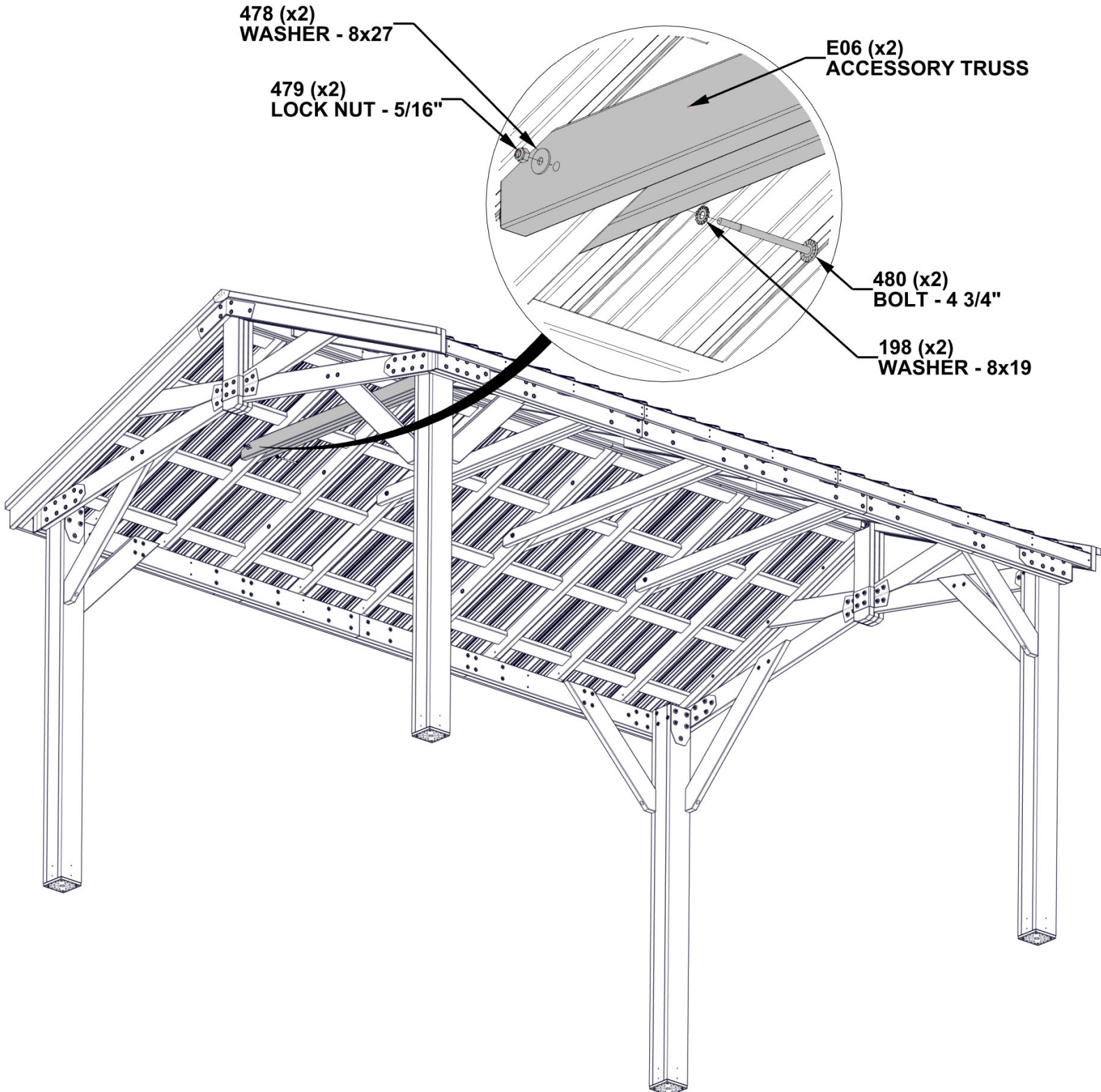

STEP 42 - GAZEBO ASSEMBLY

| QTY | PART NUMBER | DESCRIPTION |
|-----|-------------|-------------------------|
| 24 | H100201 | SCREW PFH 8 X 2 1/2 BLK |



G01 COVER BOARD - W4L16917
(x2) 1"x5 1/4"x89 1/2" (24x134x2274)

REPEAT FOR OTHER SIDE OF GAZEBO.

FOR BOARD PLACEMENT, MEASURE AS SHOWN FROM CORNER OF CORBEL. USE PILOT HOLES TO ATTACH BOARD.

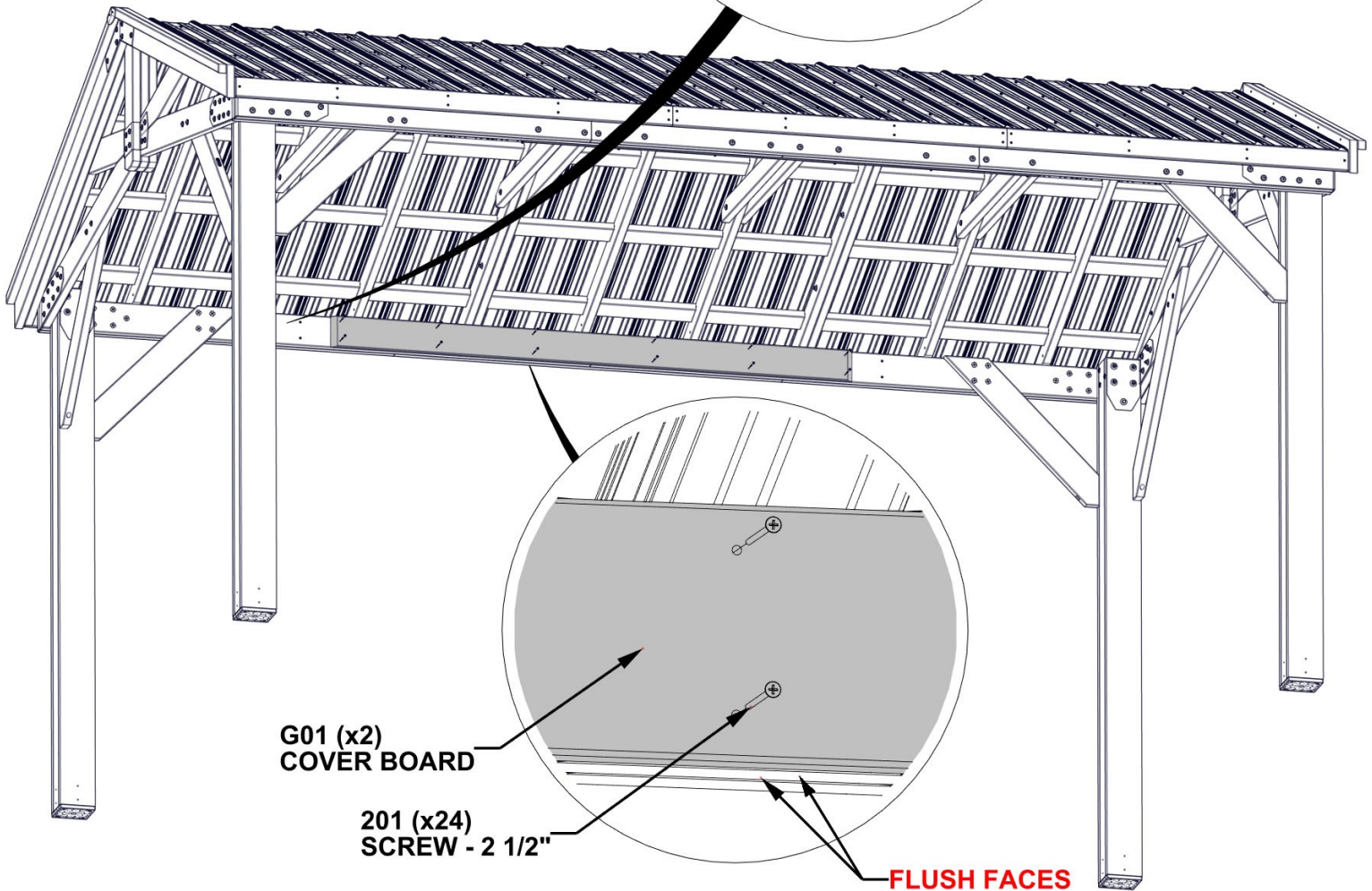
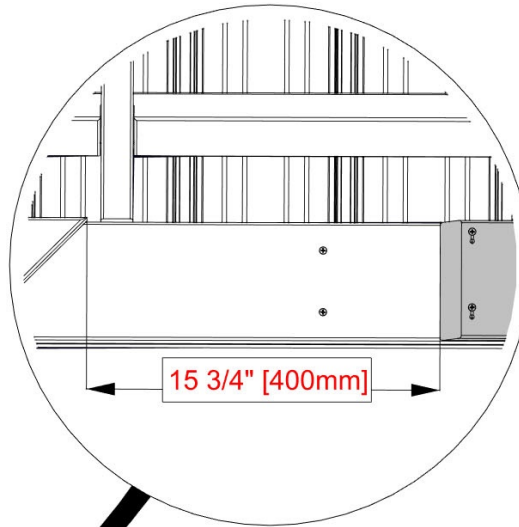

STEP 43 - ROOF ASSEMBLY

| QTY | PART NUMBER | DESCRIPTION |
|-----|-------------|-------------------------|
| 14 | H100488 | BOLT WH 1/4 X 2 BLK |
| 14 | H100630 | WASHER FLAT 8x19 BLK |
| 14 | H100653 | NUT LOCK 1/4 BLK |
| 28 | H100823 | SCREW PWH 8 X 1 1/2 BLK |

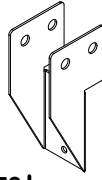

A4M01752 | RAFTER CLIP
(x14)

630 (x14)
WASHER - 8x19

653 (x14)
LOCK NUT - 1/4"

823 (x28)
SCREW - 1 1/2"

488 (x14)
BOLT - 2"

**USE THIS BOLT HOLE FOR
CENTER THREE RAFTER CLIPS.**

1752 (x14)
RAFTER CLIP

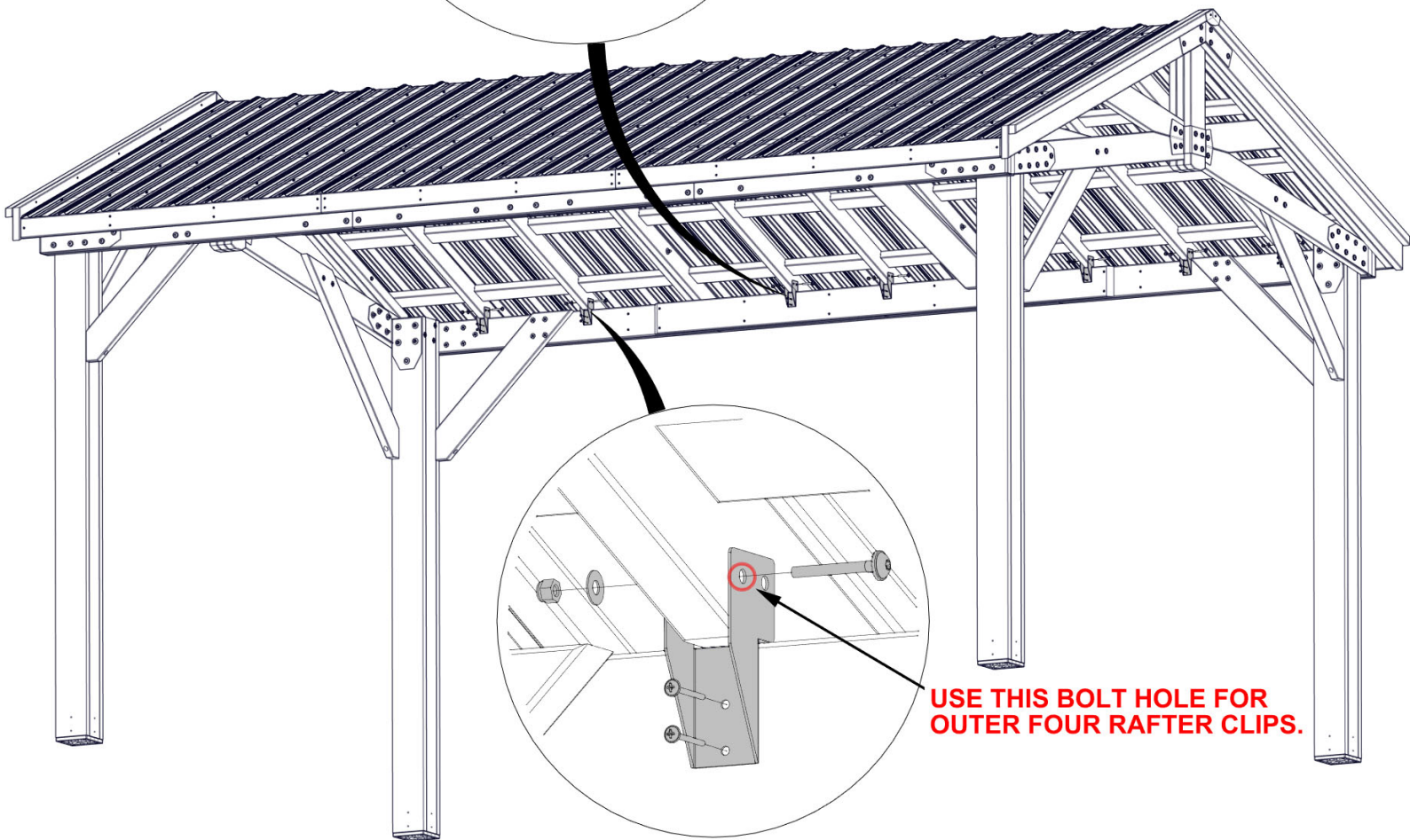

**USE THIS BOLT HOLE FOR
OUTER FOUR RAFTER CLIPS.**

STEP 44 - ROOF ASSEMBLY

| QTY | PART NUMBER | DESCRIPTION |
|-----|-------------|--------------------------|
| 28 | H100759 | SCREW SELF TAPPING 1/4x1 |



COMPLETE ON BOTH SIDES.

SCREWS GO THROUGH EDGE TRIM INTO THE TOP OF THE RIBS IN THE APPROXIMATE LOCATIONS SHOWN.

DUE TO MULTIPLE LAYERS OF METAL ON THE EDGE TRIM, IT IS RECOMMENDED THAT A 1/8" DRILL BIT IS USED TO CREATE STARTER HOLES.

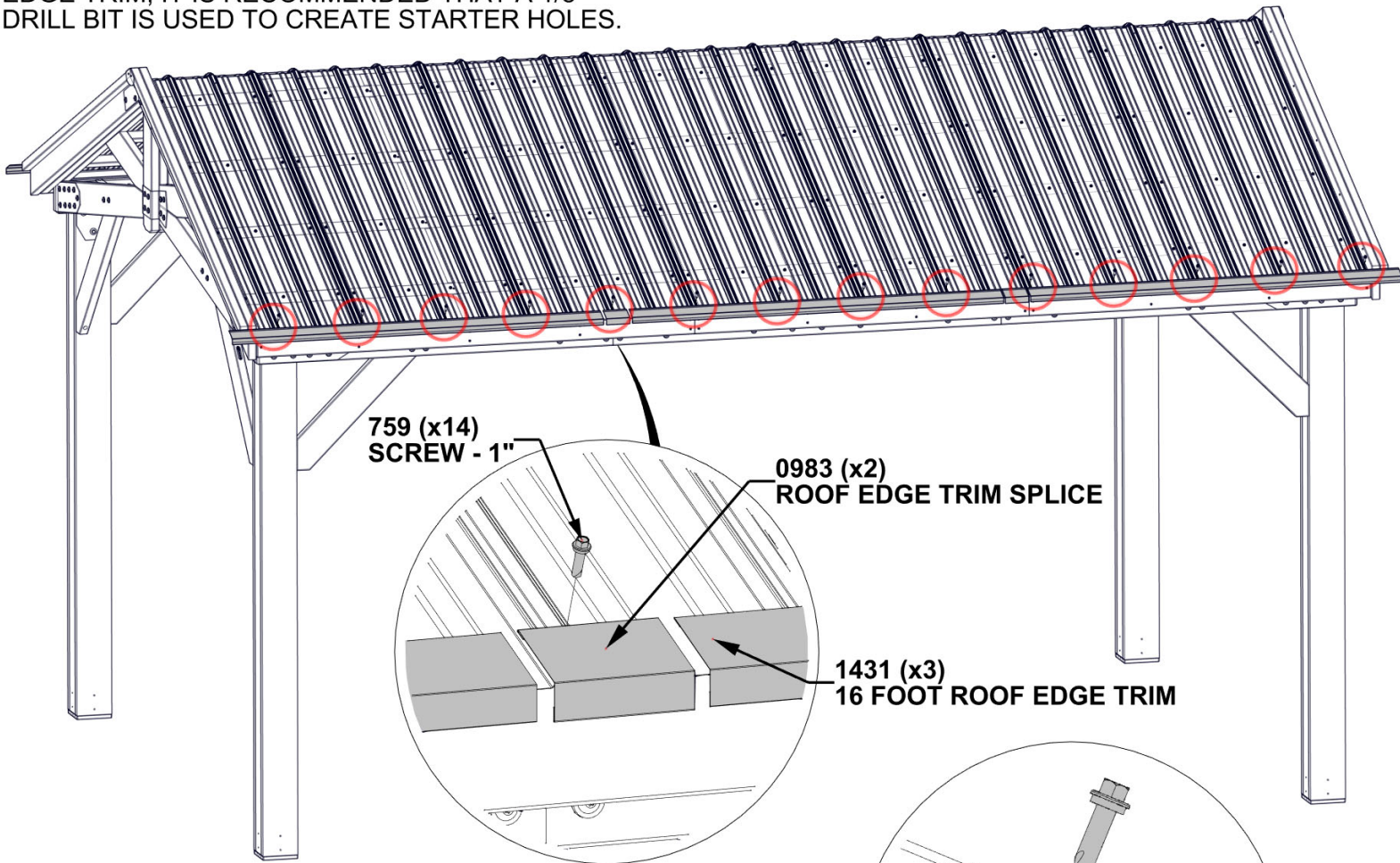

SLIDE TRIM INTO SPLICE ENSURING THAT BOTH ENDS ARE FLUSH WITH THE EDGES OF ROOF PANELS.

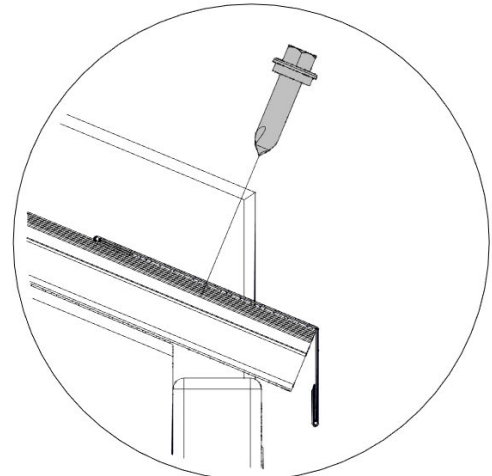

SIDE VIEW

STEP 45 - ROOF ASSEMBLY

A4M01127
(x2) | RIDGE CAP SPLICE

A4M01430
(x3) | 16 FOOT RIDGE CAP 29 GA

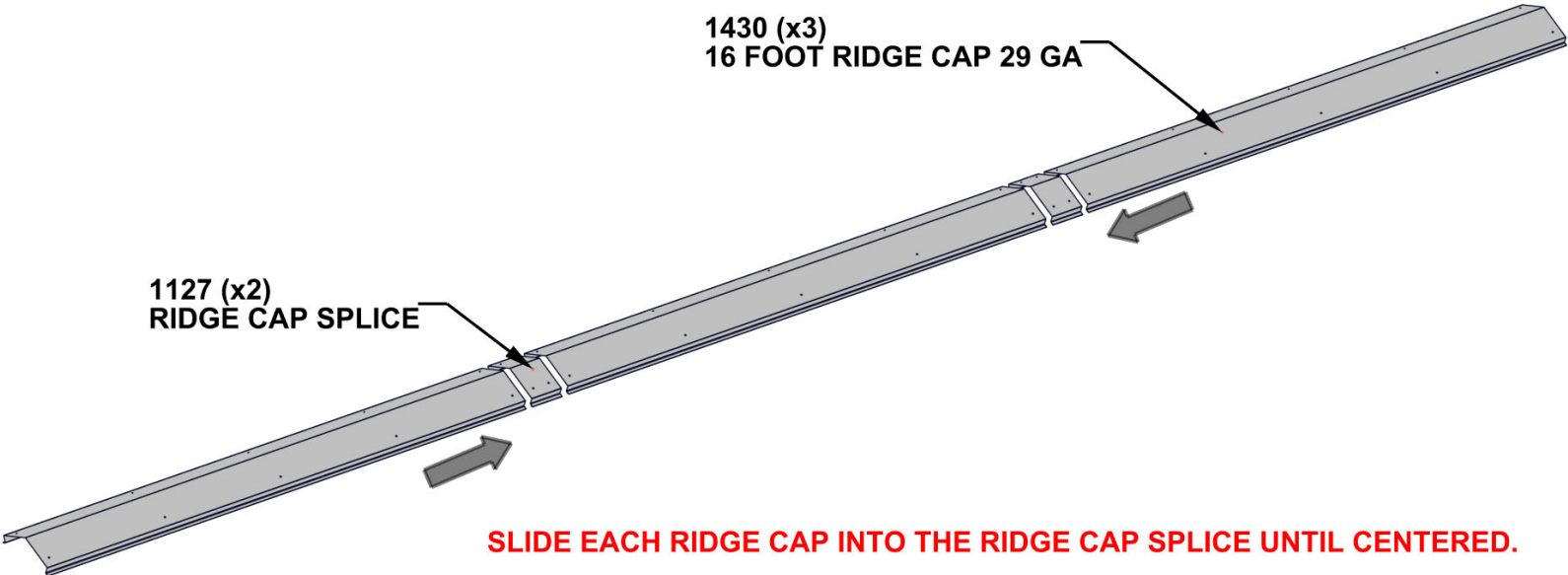

STEP 46 - ROOF ASSEMBLY

| QTY | PART NUMBER | DESCRIPTION |
|-----|-------------|----------------------------|
| 30 | H100833 | SCREW WOODGRIP 10-16 x 3/4 |



J09 | RIDGE CAP STIFFENER - W4L16876
(x4) | 1"x2 3/8"x53 7/8" (24x60x1367)

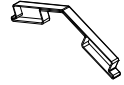

J10 | RIDGE CAP STIFFENER - W4L16877
(x2) | 1"x2 3/8"x83 1/2" (24x60x2121)

A6P00398 | RIDGE CAP PROTECTOR
(x2)

**ASSEMBLE BY ALIGNING THE HOLES ON EACH RIDGE CAP TO THE HOLES IN THE RIDGE CAP SPLICE.
FINAL LENGTH - 15'-11 5/16" [4859mm]**

REMOVE SPACERS FROM RIDGE CAP PROTECTORS BEFORE INSTALLING.

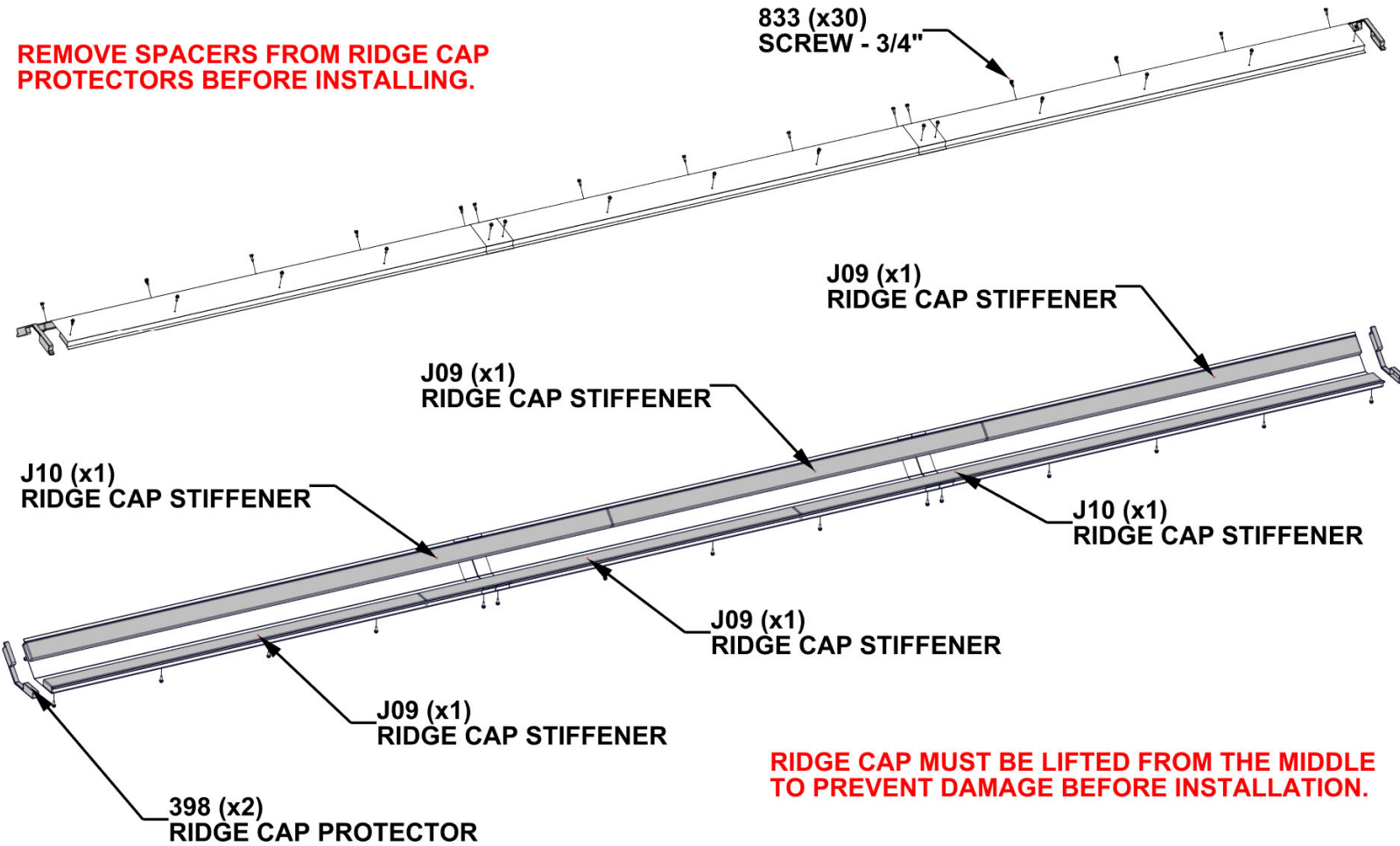

RIDGE CAP MUST BE LIFTED FROM THE MIDDLE TO PREVENT DAMAGE BEFORE INSTALLATION.

STEP 47 - ROOF ASSEMBLY

| QTY | PART NUMBER | DESCRIPTION |
|-----|-------------|-----------------------|
| 26 | H100392 | SCREW PWH 8 X 3/4 BLK |



RIDGE CAP ASSEMBLY FROM PREVIOUS STEP

**DO NOT CLIMB ON ROOF TO INSTALL:
ROOF CAP HAS BEEN DESIGNED TO
INSTALL WITH THE USE OF A LADDER.**

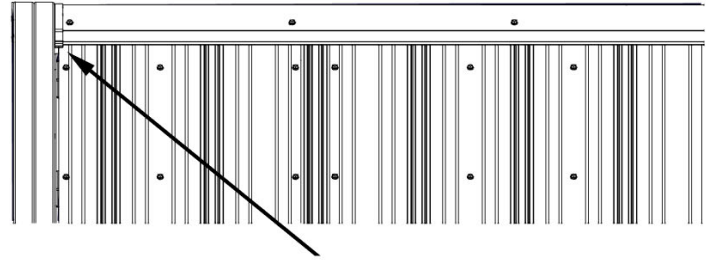
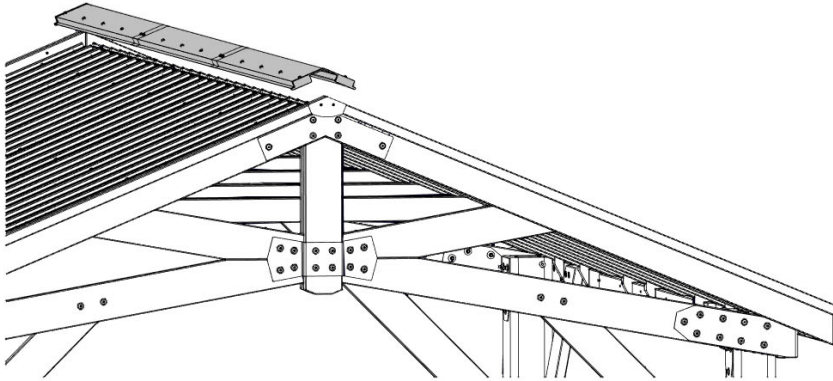

USING AN ADULT HELPER, SLIDE RIDGE CAP ASSEMBLY ACROSS THE ROOF RIDGE UNTIL BOTH ENDS SIT INSIDE RAFTERS AS SHOWN.

FOR PROPER INSTALLATION, USE AN ADULT HELPER TO KEEP DOWNWARD PRESSURE ON THE RIDGE CAP WHILE SCREWING IN SCREWS.

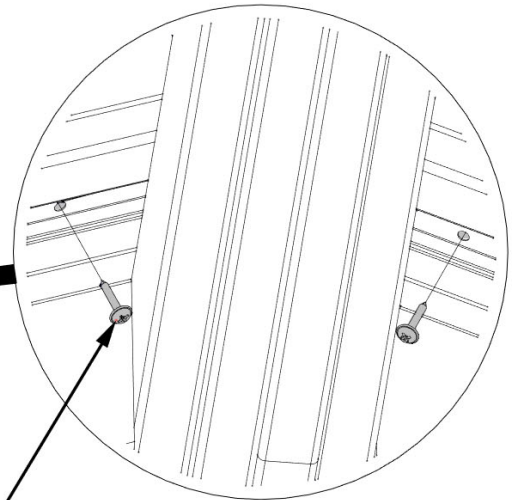
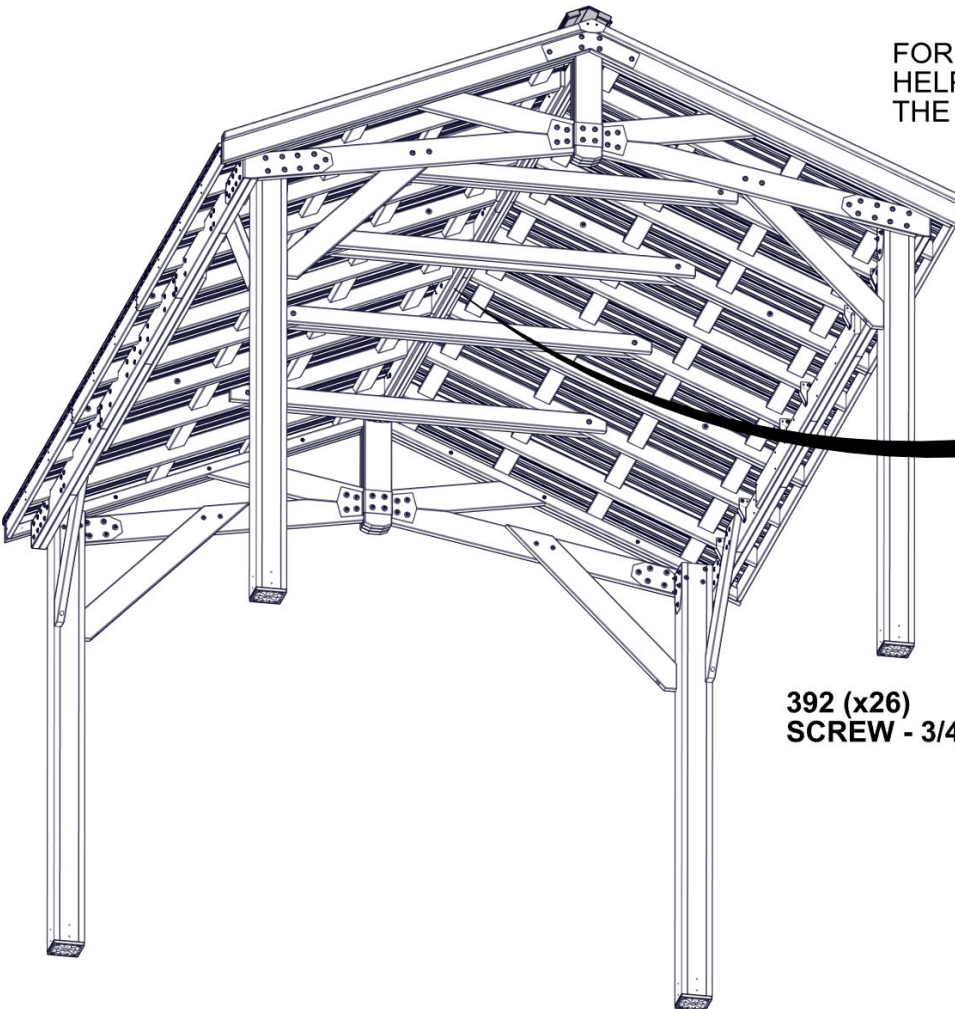

**392 (x26)
SCREW - 3/4"**

INSTALL SCREWS THROUGH PILOT HOLES IN ROOF PANELS INTO RIDGE CAP STIFFENER BOARDS.

STEP 48 - GAZEBO ASSEMBLY

| QTY | PART NUMBER | DESCRIPTION |
|-----|-------------|-------------------------------|
| 32 | H100471 | LAG SCREW WH 5/16 X 1 1/2 BLK |

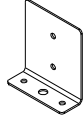

A4M00977 | POST ANCHORING
(x8) | PLATE



A4M00978 | POST PLATE
(x8)

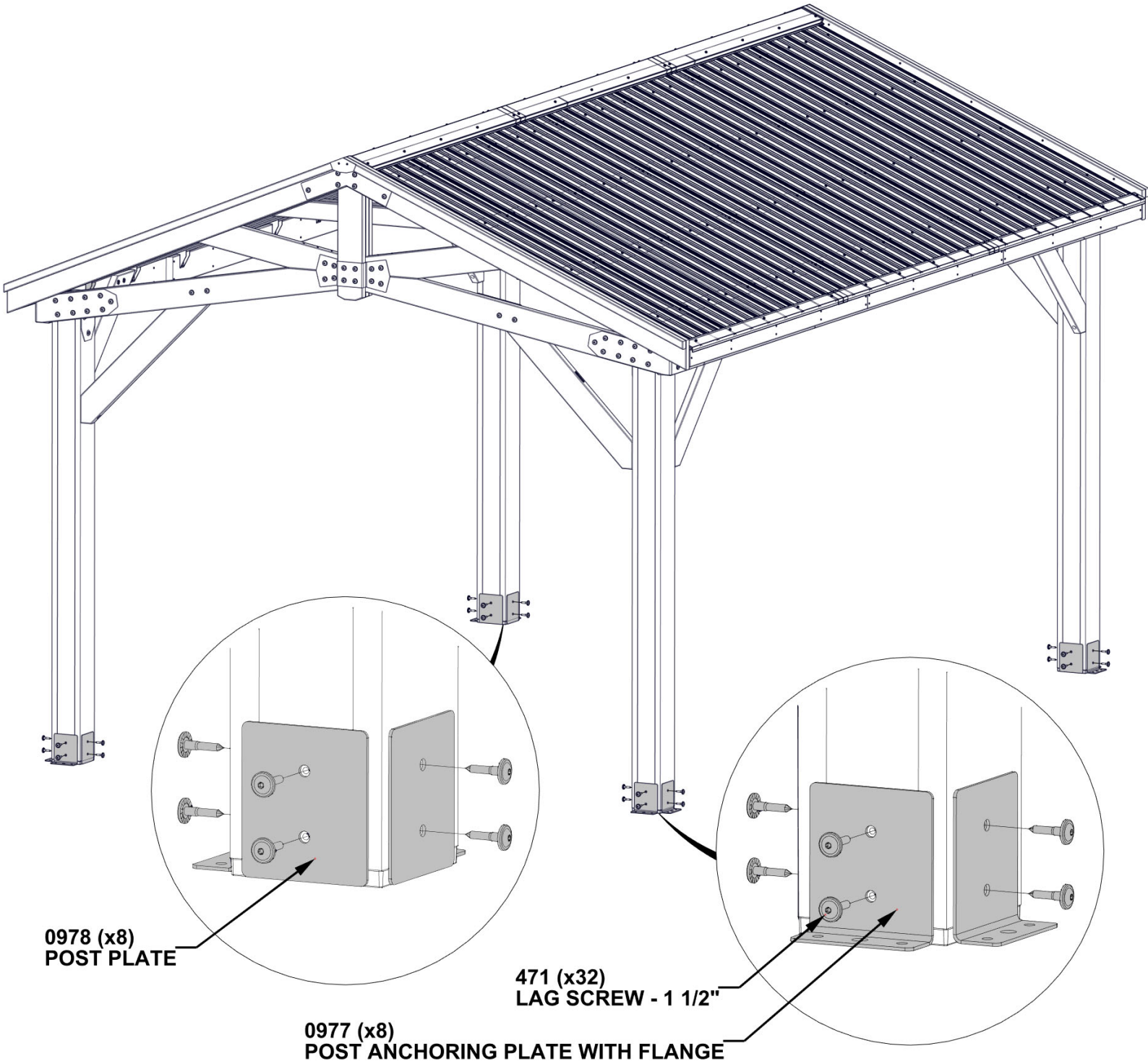

STEP 49 - GAZEBO ASSEMBLY

| QTY | PART NUMBER | DESCRIPTION |
|-----|-------------|-------------------------|
| 2 | H100200 | SCREW PFH 8 X 1 1/2 BLK |



A100241 | **BYD ID TAG**
(x1) | **(SMALL)**
WITHOUT AGES

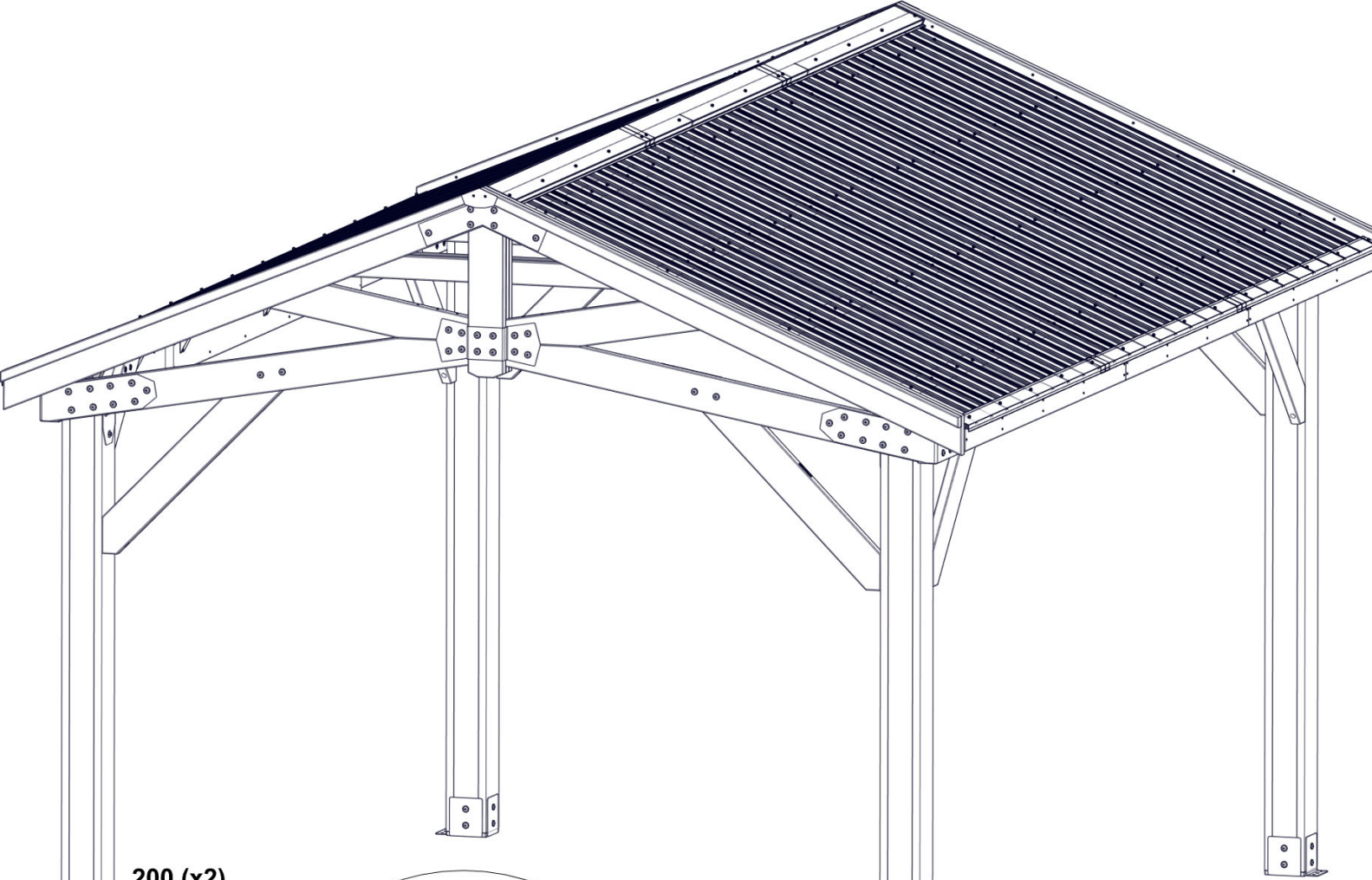

200 (x2)
SCREW - 1 1/2"

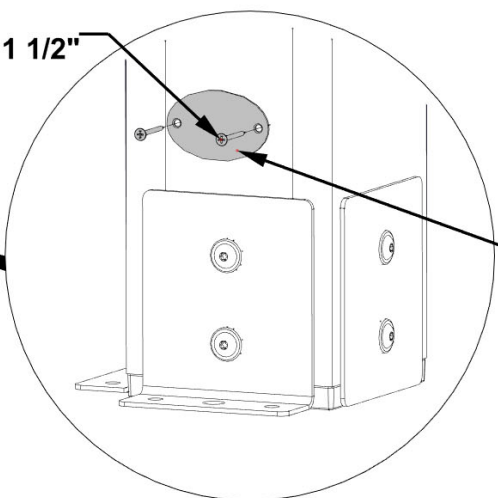

241 (x1)
BYD ID TAG (SMALL) WITHOUT AGES

STEP 50 - GAZEBO ASSEMBLY

| QTY | PART NUMBER | DESCRIPTION |
|-----|-------------|----------------------|
| 16 | H100120 | CONCRETE ANCHOR |
| 16 | H100630 | WASHER FLAT 8x19 BLK |

MANUFACTURER RECOMMENDS INSTALLATION ON CONCRETE SURFACE OR CONCRETE POST PAD AS SHOWN BELOW.

FOR INSTALLATION ON WOOD DECK, YOU MUST ENSURE THERE IS AMPLE STRUCTURAL SUPPORT UNDER THE DECK. HARDWARE NOT INCLUDED FOR DECK ATTACHMENT.

