

ASSEMBLY INSTRUCTIONS

5PC MASON DINING SET

ASSEMBLY REQUIREMENTS

2-Person
Assembly

Assembly Time
(Approximate)

30 MINUTES

Thank you for purchasing our product!

Please refer and use this assembly instruction to assemble the product.
Contact our customer service department in case there are any missing or damage parts or hardware. Replacement parts are normally shipped within 2 or 3 days.

**PRODUCTS PURCHASED THROUGH OUR
AUTHORIZED VENDORS ONLY ARE
ELIGIBLE FOR REPLACEMENT PARTS**

We appreciate your business!

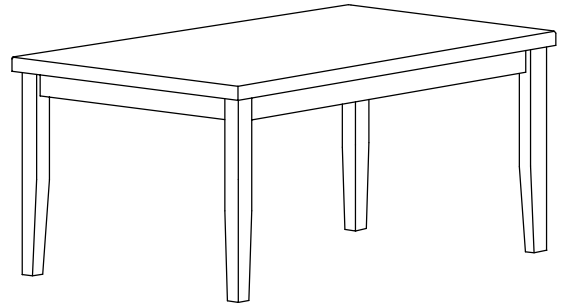

**THIS PRODUCT IS FOR INDOOR AND HOUSEHOLD USE ONLY
- NOT FOR COMMERCIAL USE.**

ASSEMBLY PREPARATION

1. Remove all packaging materials, staples and packing straps from the carton.
2. Refer to Part List and Hardware List and ensure they are complete before you start assembling.
3. Place all wooden parts on a clean, flat and soft surface (e.g. carpet or rug) to prevent parts from getting scratched.

SAFETY PRECAUTION:

1. KEEP ALL HARDWARE PARTS OUT OF REACH OF CHILDREN.
2. DISPOSE PLASTIC PACKAGING MATERIAL IMMEDIATELY TO AVOID ANY RISK OF SUFFOCATION TO CHILDREN AND ANIMALS.

TIPS FOR ASSEMBLY:

1. Allow ample room for assembly and in close proximity to where product will be placed.
2. Assemble the product on a surface that does not scratch or damage the exterior gloss and finish of the furniture.
3. Please check all of the parts and quantities are included before assembly. Contact customer service for missing parts.
4. Identify all of the parts, hardware and quantities required for each step.
5. During assembly, do not over-tighten any fittings as this may cause damage.
6. DO NOT USE POWER TOOLS TO ASSEMBLE THIS PRODUCT.
7. Always place the product on a flat surface.
8. Do not sit or stand on the partially assembled product; only use the product for which it is intended.

CARE AND MAINTENANCE

- Use a slightly damp cloth to clean the product. Do not use bleach or abrasive cleaning material.
- Check all the fittings periodically and re-tighten as necessary. Do not use the product if any of the parts is damaged or broken.
- Never allow any kind of liquid to remain on your furniture. Absorption can cause wood to warp or delaminate.
- Do not place hot items (e.g. hot drinks) directly onto the wood surface.
- Do not drag and/or pull the furniture.





ASSEMBLY INSTRUCTIONS

5PC MASON DINING SET

PARTS LIST

NO.	COMPONENT	QTY.
P1	TABLE TOP WITH APRON	1 PC.
P2	TABLE LEG	4 PCS.

HARDWARE LIST

NO.	DESCRIPTION	QTY.	EXTRA
H1	HEX BOLT 5 / 16" x 2-1/2" 	8 PCS.	1 PC.
H2	SPRING WASHER 5/16" 	8 PCS.	1 PC.
H3	FLAT WASHER 5/16" 	8 PCS.	1 PC.
H4	WRENCH 	1 PC.	-

*EXTRA HARDWARE FOR SPARE USE

STEP 1

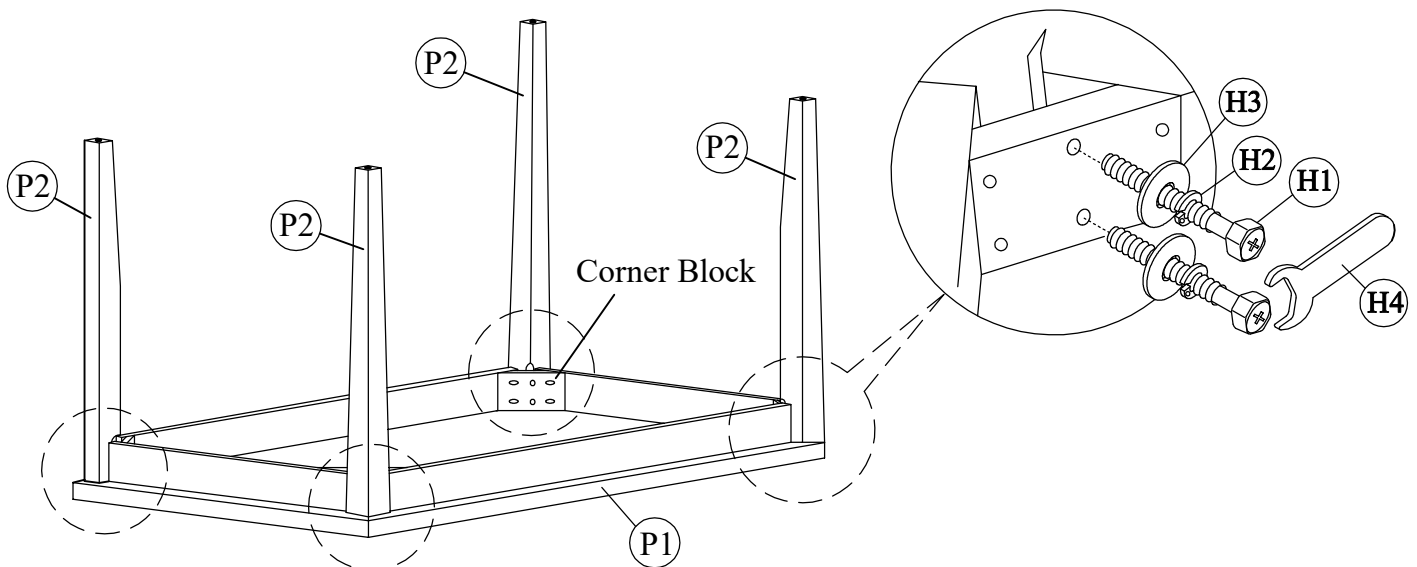

- a) With the assistance of another person, place Table Top (P1) bottom-side up on a flat, level surface and soft material to prevent scratch and damage.
- b) Position a Table Leg (P2) against a corner of the table aprons and align the screw holes on (P2) to the screw holes on the corner block.
- c) Insert Hex Bolt (H1) fitted with Spring Washer (H2) and Flat Washer (H3) into each hole. Use Wrench (H4) to drive (H1) to fasten Table Leg (P2) to corner block. Do not tighten (H1) completely until both bolts are in place - **do not over-tighten.**
- d) Repeat the above assembly procedure for the other three table legs .
- e) With the assistance of another person , set the table right-side up. The assemble of the table is complete.

ASSEMBLY INSTRUCTIONS

5PC MASON DINING SET

ASSEMBLY
REQUIREMENTS

1-Person
Assembly

30 Minutes
Assembly Time
(Approximate)

Tool Required
(Not Provided)

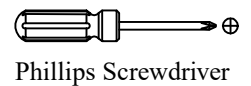
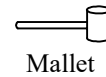

Thank you for purchasing our product!

Please refer and use this assembly instruction to assemble the product.
Contact our customer service department in case there are any missing or damage parts or hardware. Replacement parts are normally shipped within 2 or 3 days.

**PRODUCTS PURCHASED THROUGH OUR
AUTHORIZED VENDORS ONLY ARE
ELIGIBLE FOR REPLACEMENT PARTS**

We appreciate your business!

**THIS PRODUCT IS FOR INDOOR AND HOUSEHOLD USE ONLY
- NOT FOR COMMERCIAL USE.**

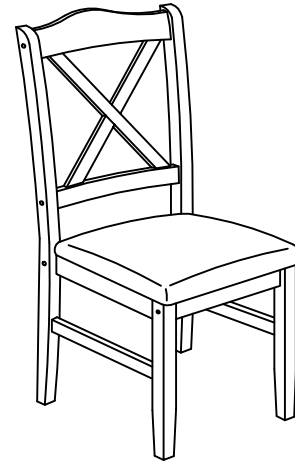

ASSEMBLY PREPARATION

1. Remove all packaging materials, staples and packing straps from the carton.
2. Refer to Part List and Hardware List, and ensure parts and hardware are complete before you start assembling. Contact customer service for missing parts.
3. Place all wooden parts on a clean, flat and soft surface (e.g. carpet or rug) to prevent parts from getting scratched.

SAFETY PRECAUTION:

1. KEEP ALL HARDWARE PARTS OUT OF REACH OF CHILDREN.
2. DISPOSE PLASTIC PACKAGING MATERIAL IMMEDIATELY TO AVOID ANY RISK OF SUFFOCATION TO CHILDREN AND ANIMALS.

TIPS FOR ASSEMBLY:

1. Allow ample room for assembly and in close proximity to where product will be placed.
2. Assemble the product on a surface that does not scratch or damage the exterior gloss and finish of the furniture.
3. Check all of the parts and quantities are included before assembly.
4. Identify all of the parts, hardware and quantities required for each step.
5. During assembly, do not over-tighten any fittings as this may cause damage.
6. DO NOT USE POWER TOOLS TO ASSEMBLE THIS PRODUCT.
7. Always place the product on a flat, level surface.
8. Do not sit or stand on the partially assembled product; only use the product for which it is intended.

CARE AND MAINTENANCE

- Use a slightly damp cloth to clean the product. Do not use bleach or abrasive cleaning material.
- Check all the fittings periodically and re-tighten as necessary. Do not use the product if any of the parts is damaged or broken.
- Never allow any kind of liquid to remain on your furniture. Absorption can cause wood to warp or delaminate.
- Do not place hot items (e.g. hot drinks) directly onto the wood surface.
- Do not drag and/or pull the furniture.

ASSEMBLY INSTRUCTIONS

5PC MASON DINING SET

PARTS LIST

NO.	COMPONENT	QTY.
P1	BACKREST FRAME	4 PCS.
P2	CENTER RAIL	4 PCS.
P3	BACK LEG (LEFT & RIGHT)	8 PCS.
P4	FRONT APRON	4 PCS.
P5	FRONT LEG (LEFT & RIGHT)	8 PCS.
P6	SIDE APRON	8 PCS.
P7	SIDE STRETCHER (LEFT & RIGHT)	8 PCS.
P8	CUSHION SEAT	4 PCS.

HARDWARE LIST

NO.	DESCRIPTION	QTY.	EXTRA
H1	JCBC BOLT M6 x 45 MM	32 PCS.	1 PC.
H2	1/4" SPRING WASHER	32 PCS.	1 PC.
H3	JCBC/W BOLT M7 x 50 MM	24 PCS.	1 PC.
H4	WOOD DOWEL M8 x 30MM	48 PCS.	1 PC.
H5	CB SCREW M4 x 32MM	28 PCS.	1 PC.
H6	JCBC/W BOLT M7 x 60 MM	8 PCS.	1 PC.
H7	1/4" FLAT WASHER	32 PCS.	1 PC.
H8	ALLEN KEY	1 PC.	-

*EXTRA HARDWARE FOR SPARE USE

STEP 1 - Assemble Chair Back

- Insert Wood Dowel (H4) into the designated holes on Backrest Frame (P1) and Center Rail (P2) as shown. Use a mallet to lightly tap in wood dowel if necessary.
- Attach Left & Right Back Leg (P3) to Backrest Frame (P1) and Center Rail (P2) via wood dowel and fasten with JCBC Bolt (H3). Use Allen Key (H8) to drive and tighten (H3). Do not tighten (H3) completely until all the bolts are in place. **DO NOT OVER-TIGHTEN.**
- Set aside completed Chair Back assembly for use in STEP 4.

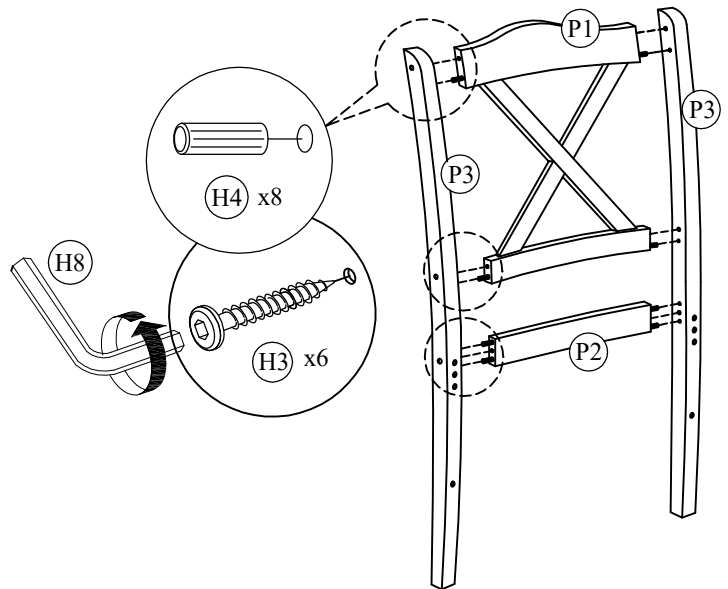

STEP 2

- Insert Wood Dowel (H4) into the designated holes on Front Apron (P4). Use a mallet to lightly tap in wood dowel if necessary.
- Attach Left & Right Front Leg (P5) to Front Apron (P4) as show via wood dowel and fasten with JCBC Bolt (H6). Use Allen Key (H8) to drive and tighten (H6). **DO NOT OVER-TIGHTEN.**

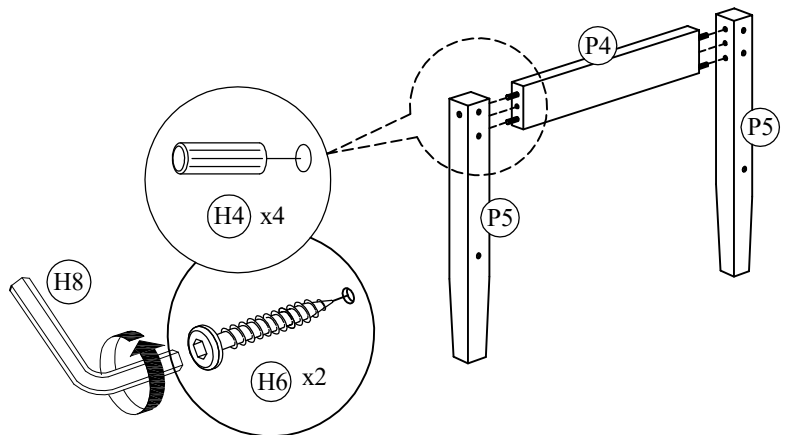

ASSEMBLY INSTRUCTIONS

5PC MASON DINING SET

STEP 3

- a) Position Side Apron (P6) on Front Leg (P5) to align the screw slot on (P6) to the screw holes on (P5) as shown and fasten with JCBC Bolt (H1) fitted with Spring Washer (H2) and Flat Washer (H7). Use Allen Key (H8) to drive (H1). Do not tighten (H1) completely at this time.
- b) Attach Left and Right Side Stretcher (P7) to Front Leg (P5). NOTE: Check that the slot for the screw is facing down towards the end of each leg.

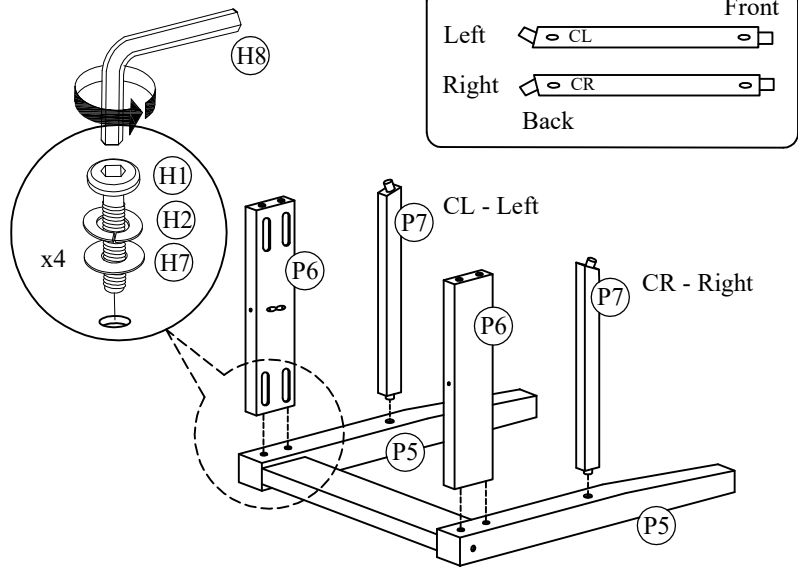

STEP 4

- a) Lay Chair Back assembly from STEP 1 as shown on a flat, level surface that does not scratch the parts.
- b) Position assembly from STEP 3 with the Side Apron (P6) on Back Leg (P3) to align the screw slots on (P6) to the screw holes on (P3) and fit the Left and Right Side Stretcher (P7) to the drilled holes on (P3). Insert JCBC Bolt (H1) fitted with Spring Washer (H2) and Flat Washer (H7). Use Allen Key (H8) to drive (H1). Do not tighten (H1) completely until all 4 bolts are in place.
- c) Tighten JCBC Bolt (H1) in STEP 3 completely at this time. DO NOT OVER-TIGHTEN.

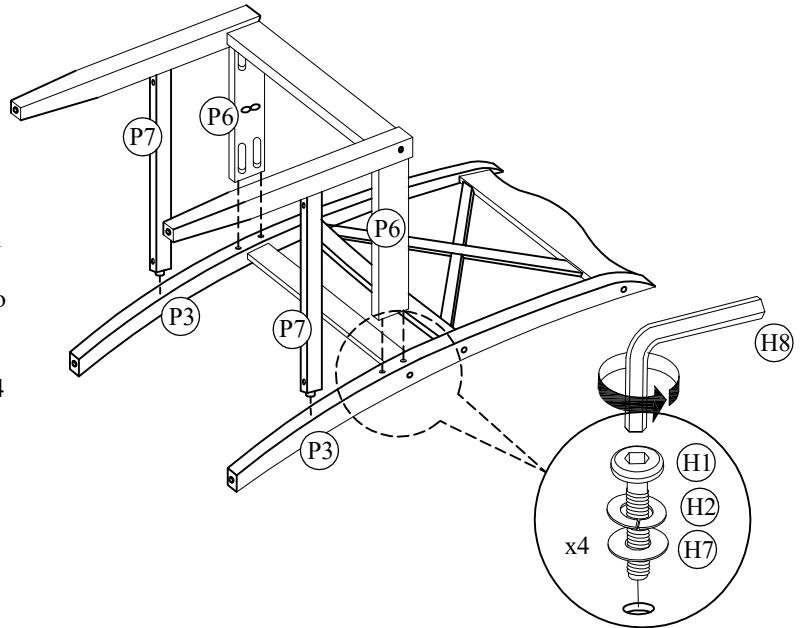

STEP 5

- a) Place the Cushion Seat (P8) bottom-side up on an elevated surface (e.g. table top).
- b) Position the Chair Frame assembly from STEP 4 with the legs facing up as shown and center seat frame to Cushion Seat (P8) with rear of the Cushion Seat against the Chair Back.
- c) Use Screw (H5) to fasten (P8) to the front and side apron of the seat frame. Use a Phillips screwdriver to drive the screws. Do not tighten the screws completely until all the screws are in place.
- d) Use Screw (H5) to fasten Side Stretchers (P7) to Front and Back Legs.

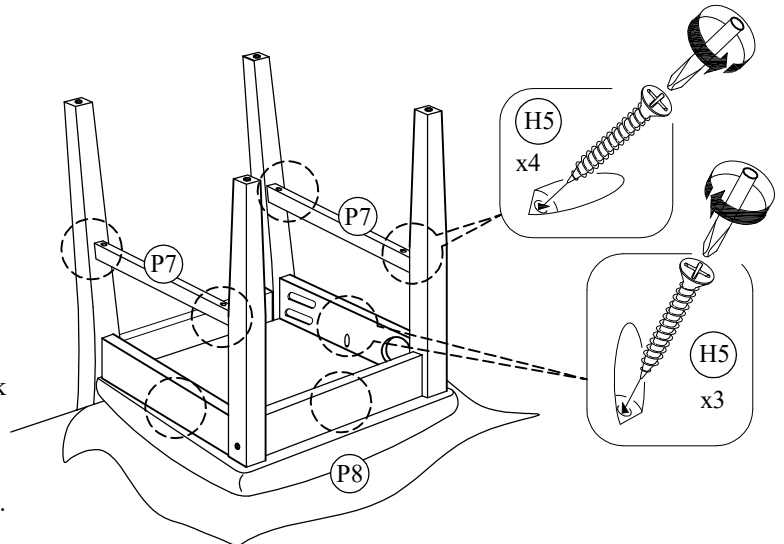

Set the chair right-side up. The assembly of the chair is complete.