

# 8FT X 12FT GARDEN STORAGE SHED ASSEMBLY MANUAL

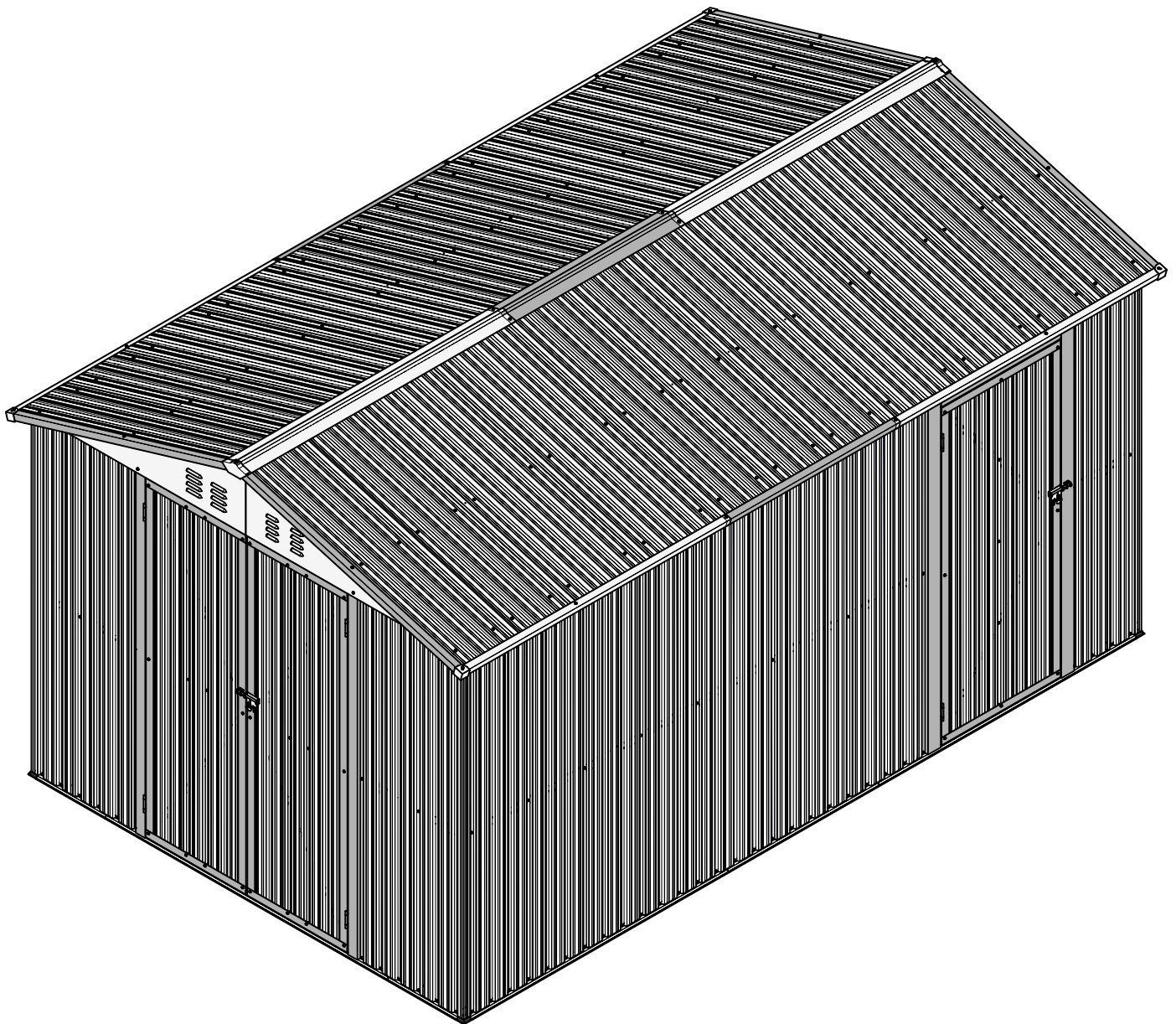

**INSIDE CARTON 1**

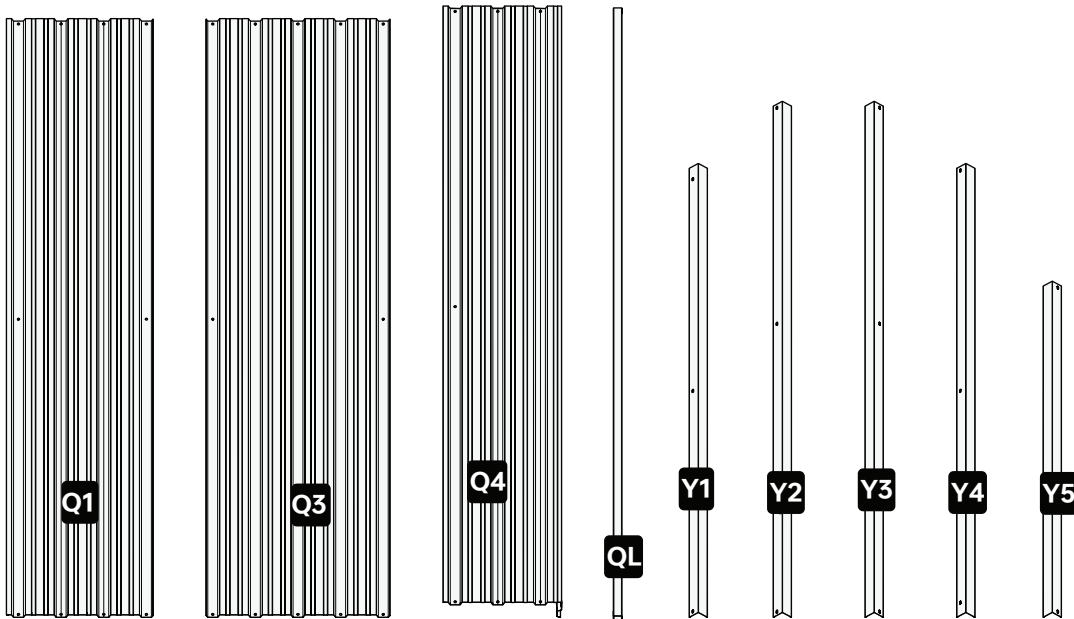
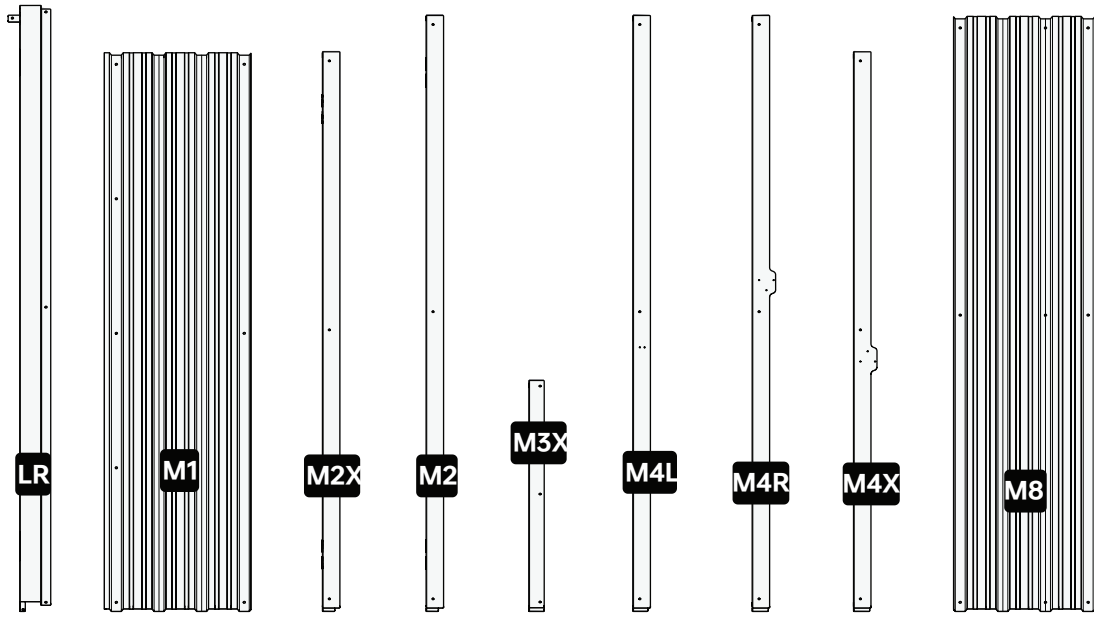
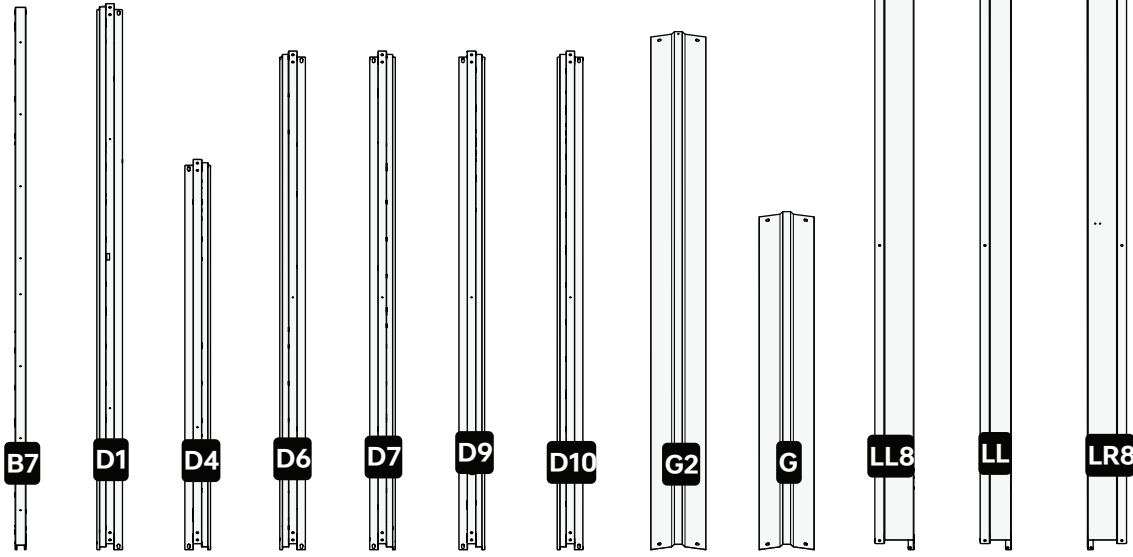

Part	Qty
B7	1
D1	1
D4	1
D6	1
D7	1
D9	1
D10	1
G2	2
G	1
LL8	1
LL	1
LR8	1
LR	1
M1	2
M2X	1
M2	2
M3X	2
M4L	1
M4R	1
M4X	1
M8	4
Q1	14
Q3	11
Q4	4
QL	4
Y1	2
Y2	2
Y3	2
Y4	2
Y5	2
BOX1	1

**BOX 1**

**INSIDE CARTON 2**

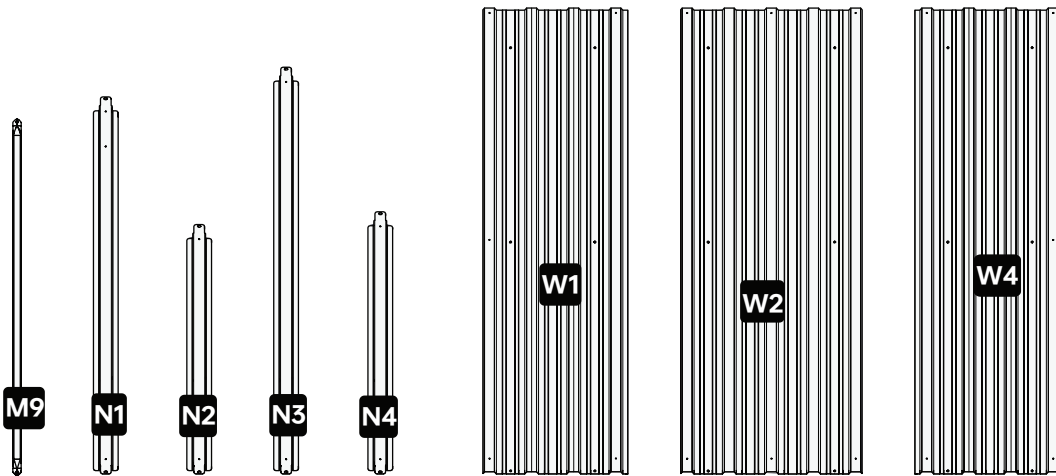
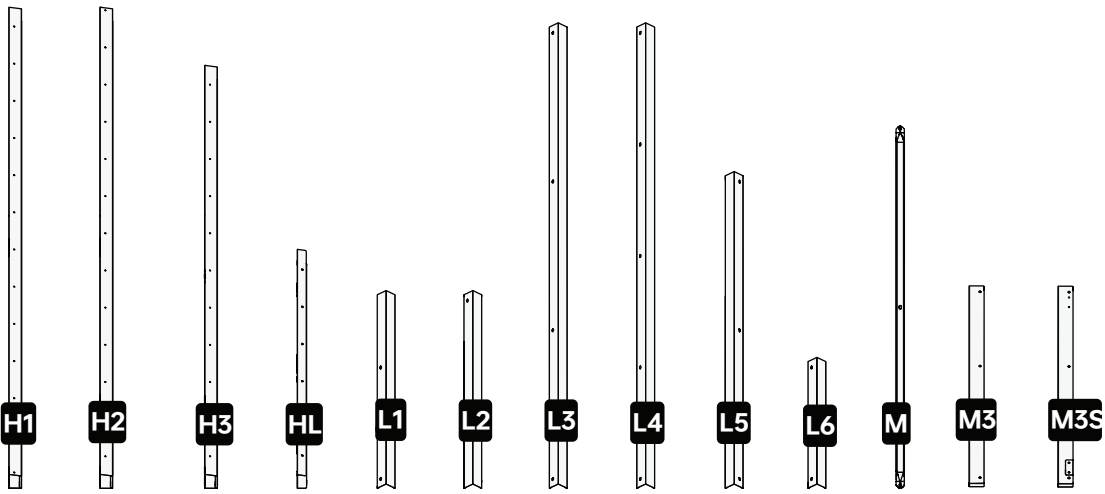
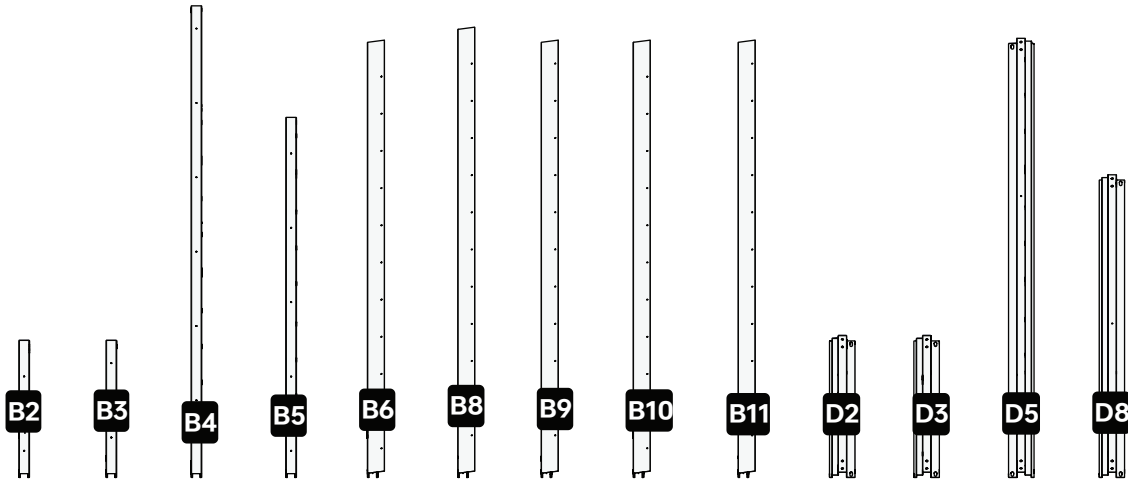

Part	Qty
B2	1
B3	1
B4	1
B5	1
B6	1
B8	2
B9	1
B10	1
B11	1
D2	1
D3	1
D5	1
D8	2
H1	4
H2	4
H3	4
HL	8
L1	2
L2	2
L3	3
L4	2
L5	1
L6	2
M	2
M3	3
M3S	1
M9	4
N1	3
N2	6
N3	4
N4	4
W1	12
W2	8
W4	2
Glove	2
BOX2	1

**BOX 2**



**INSIDE BOX 1**

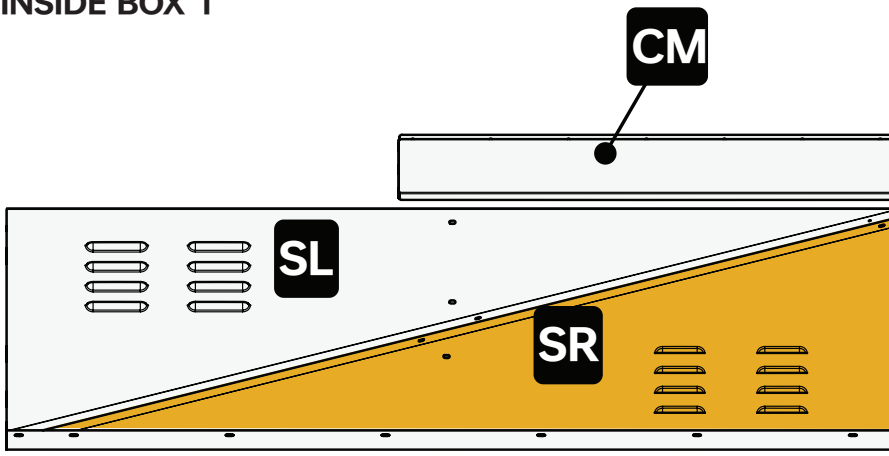

**INSIDE BOX 2**

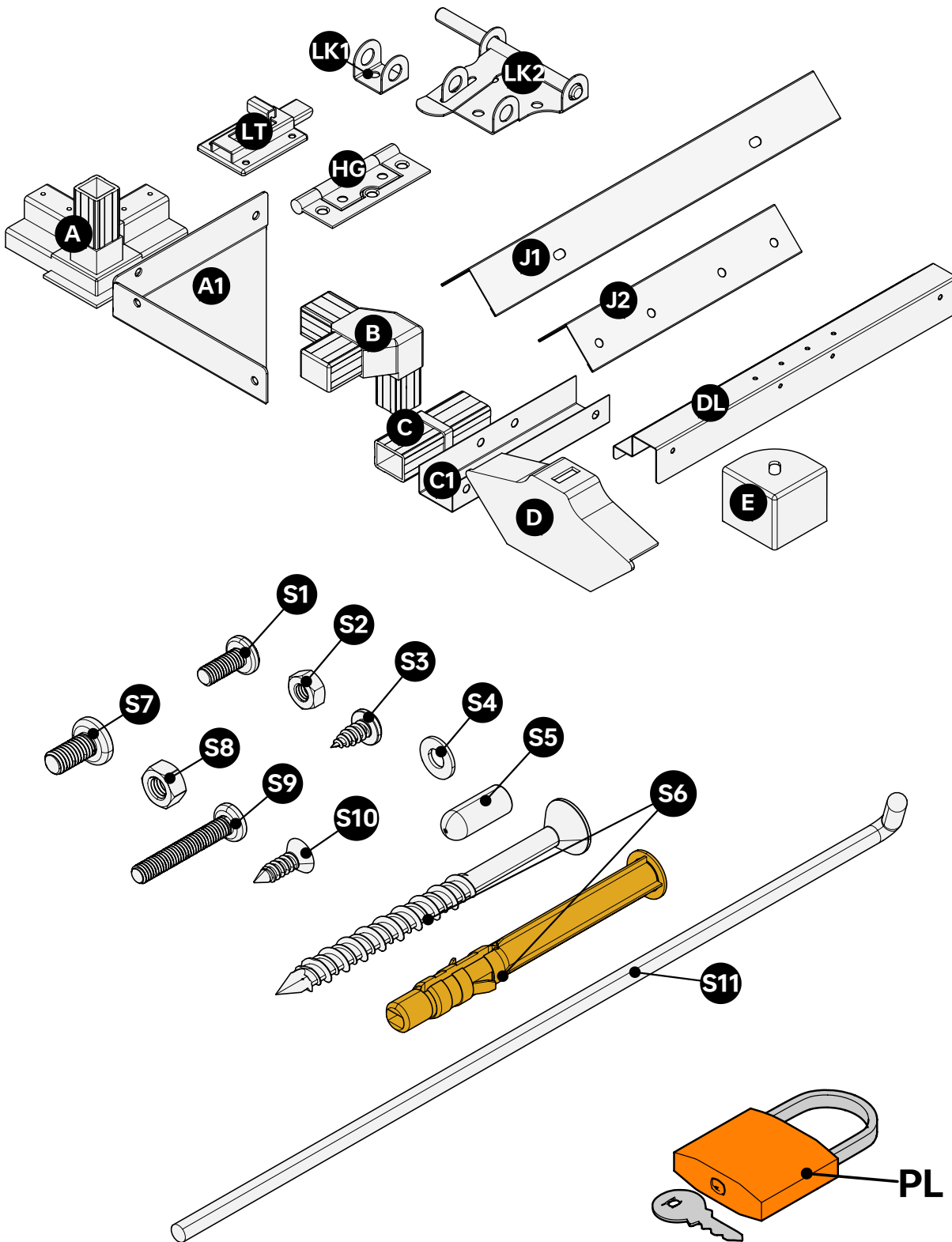

Part	Qty
<b>BOX 1</b>	
CM	1
SL	2
SR	2
<b>BOX 2</b>	
A	4
A1	4
B	4
C	7
C1	7
D	2
DL	7
E	4
HG	6
J1	4
J2	4
LK1	2
LK2	2
LT	2
S1	50
S2	78
S3	571
S4	453
S5	38
S6	4
S7	60
S8	60
S9	28
S10	6
S11	4
PL	2

# 01 Getting Started

Thank you for buying our garden Shed. Please read the manual thoroughly before assembling the shed.

## General Advice and Safety Guidelines

This product is designed for storing and sheltering items like tools, equipment and vehicles. It is not designed or intended for human or animal habitation.

It takes at least two people three hours to finish the assembly.

Assemble the shed when the weather is on your side. Avoid windy and rainy days.

Do not assemble the shed if you are tired, have taken drugs, or under the influence of alcohol.

Always wear work gloves, shoes, and safety goggles when assembling.

Keep children and pets away from the assembly site.

Watch out for overhead power cables.

Follow the instructions step by step.

Dispose of all plastic bags and protective films.

Do not climb or stand on the roof.

Do not lean against or push the unfinished shed.

## Tools

Work Gloves, Safety Goggles, Tape Measure, Level, Carpenters Square, Marker Pen, Rubber Mallet, Philips head screw driver or Power tool, M4/M5 Wrench, Ladder, Plier.

Optional: Concrete Drill with M6 Drill Bit.

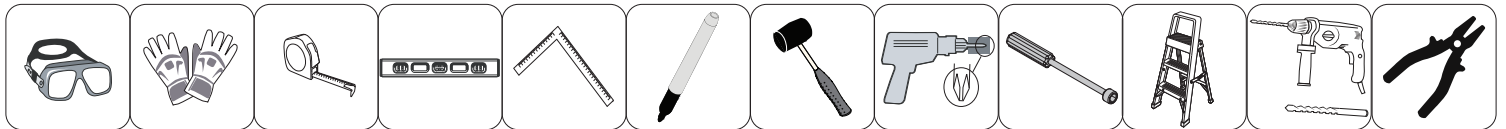

## Part Checking

Put parts on a soft and clean surface, such as a blanket. This will prevent the parts from getting scratched or dented by the hard ground.

Compare the part list with the actual parts you received.

If you find any parts missing or damaged, do not assemble the shed. Contact the seller.

### **ABOUT THE PROTECTIVE FILM**

Panels of the shed come with a thin layer of protective film. Remove the film before assembling.

### **ABOUT STACKED PARTS**

There are cases where two parts are stacked firmly and may appear to be a whole part.

## Care and Maintenance

Clean the shed once assembly is done.

Use warm water, mild detergent, and a soft sponge or cloth to clean the surface.

Clear snow from the roof top after each snowfall.

Do not store recently used grills, blowtorches, paint, etc in your shed.

# 02 Assembly Site

## Location

This garden shed occupies an area of 8.88m<sup>2</sup> (95.23ft<sup>2</sup>) on the ground, with a length of 2.4m (7.87ft) and a width of 3.7m (12.1ft).

Additionally, the shed should have at least 0.91m (3ft) of clearance on all sides from any obstacles, such as trees, fences, or buildings. This allows for adequate ventilation, drainage, and access to the shed. Make sure there are no hidden pipes, cables, or septic tank in the ground.

## Two Foundation Options

This shed must be anchored to a level and solid foundation to increase its stability.

In the package there are bolts and parts to accommodate the following foundation options:

1. Anchored to a concrete foundation.
2. Anchored into the ground.

Details about the two foundation options will be discussed in later steps.

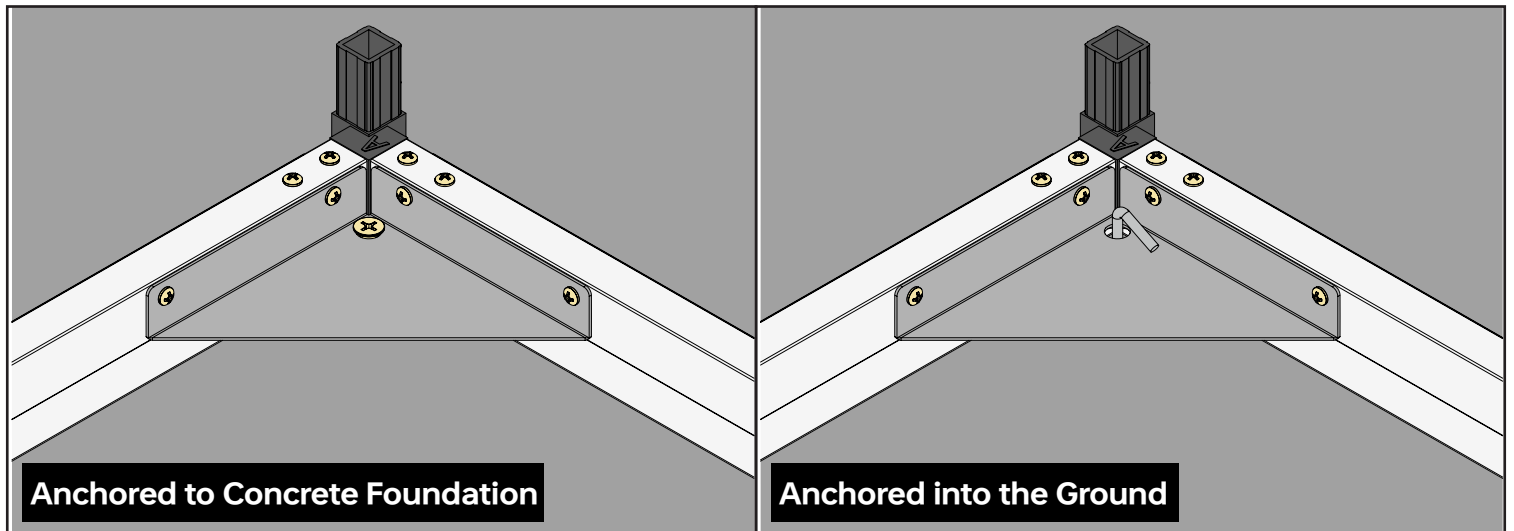

# 03 Side Door Position

The side door can be installed on either the left or right side, depending on your preference. Detailed assembly instructions for the side door will be provided in later chapters.

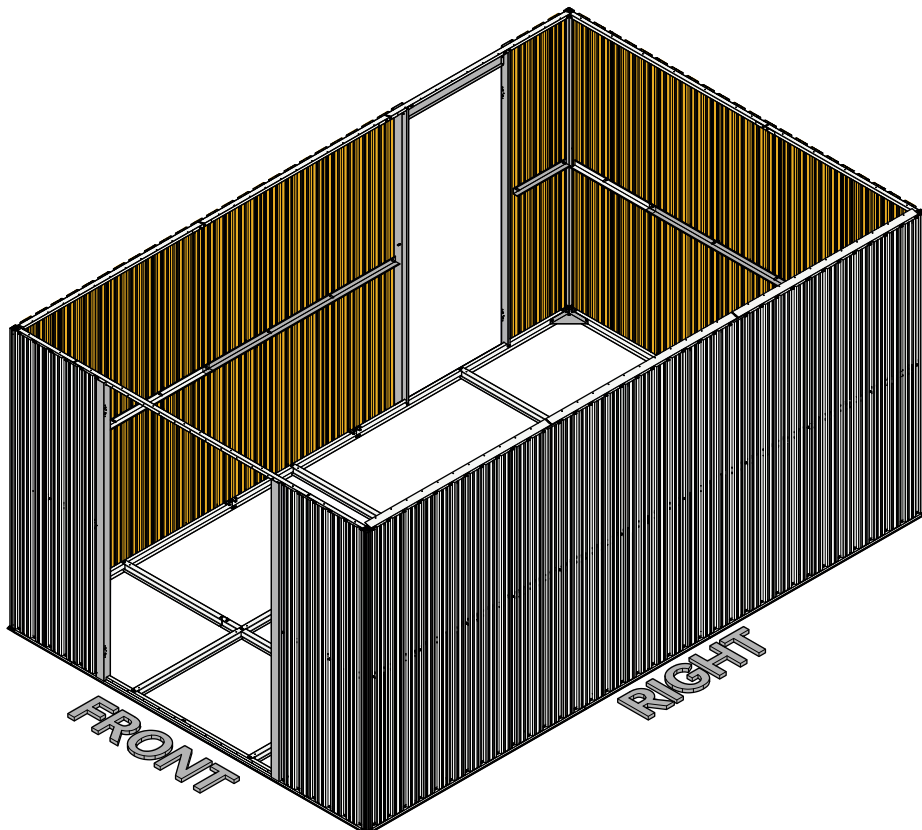
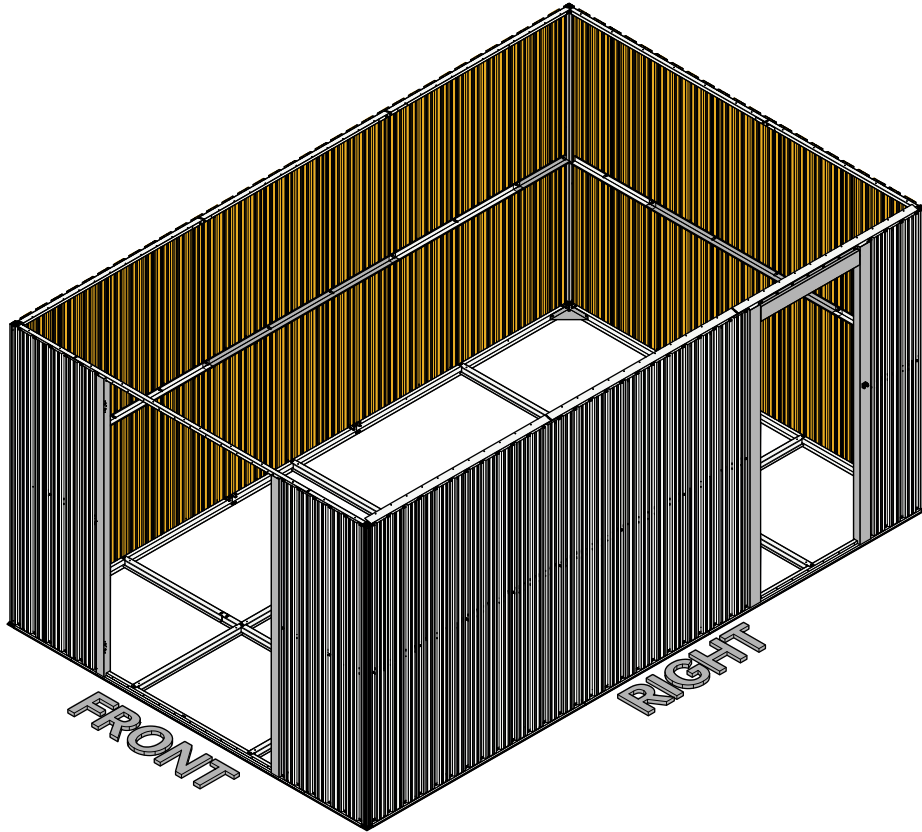

# 04 Base Frame

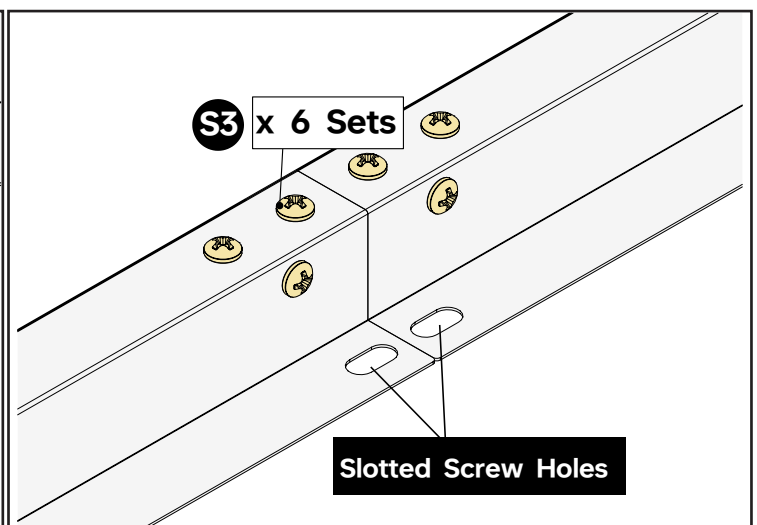
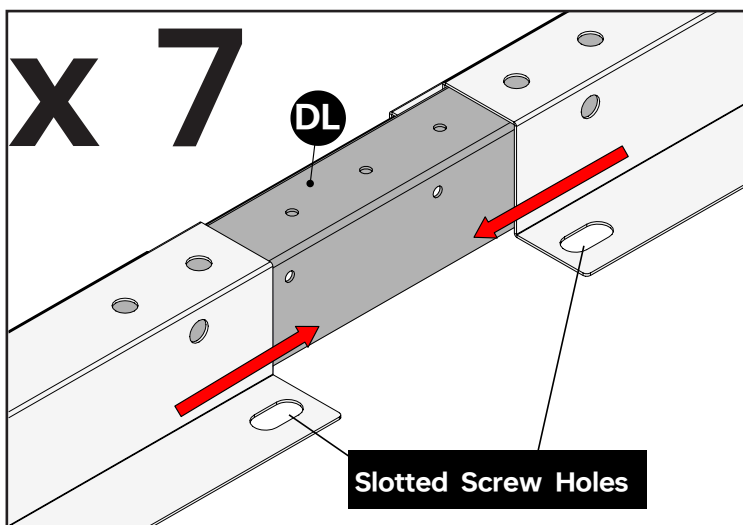
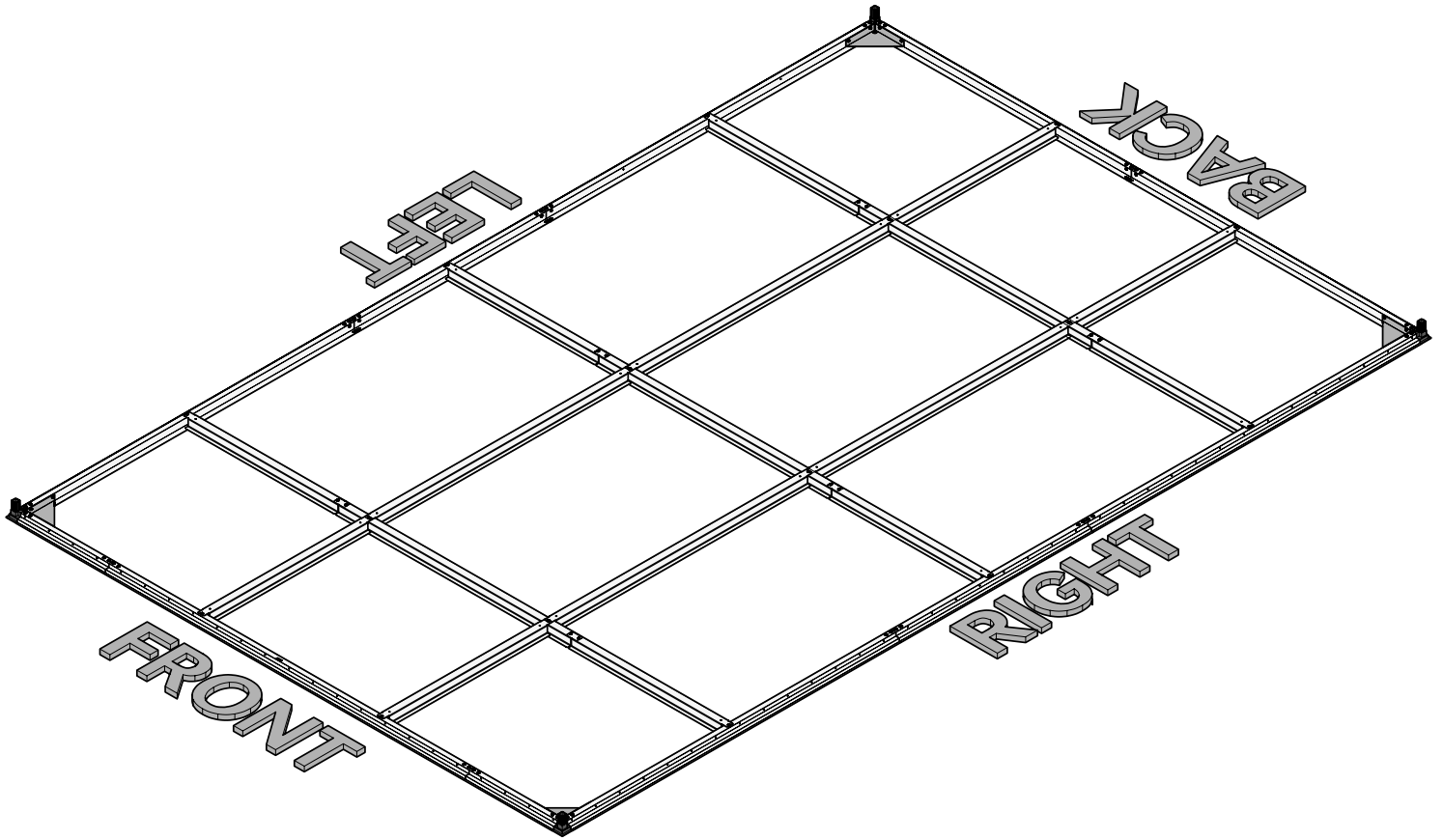

## NOTE

In this manual, the bigger mark like x 7 means you will need to repeat this sub-step 7 times, and the smaller sign like S3 x 6 Sets means this sub-step uses 6 sets of S3.

Part	Qty
D1	1
D2	1
D3	1
D4	1
D5	1
D6	1
D7	1
D8	2
D9	1
D10	1
DL	7
S3	42

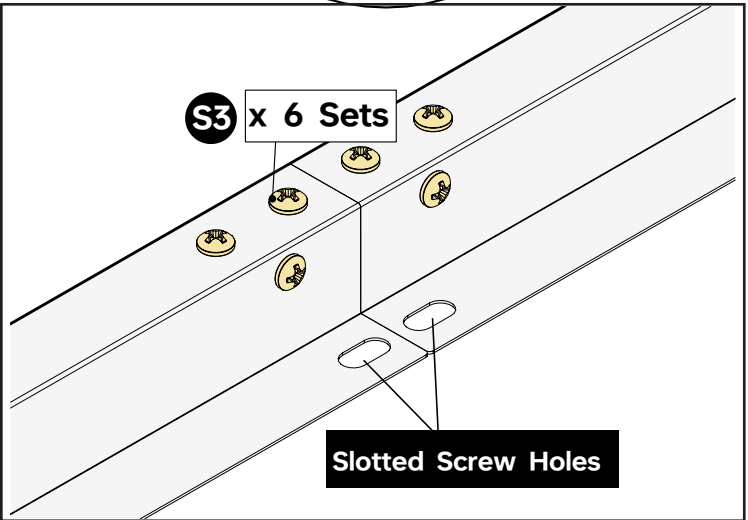
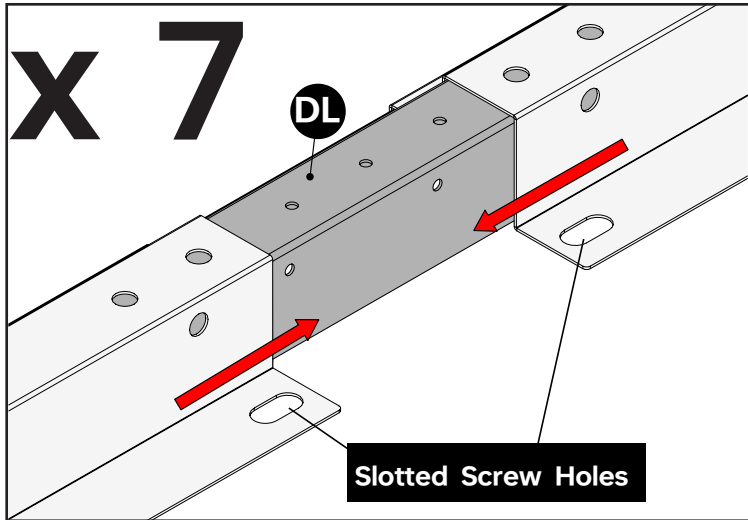
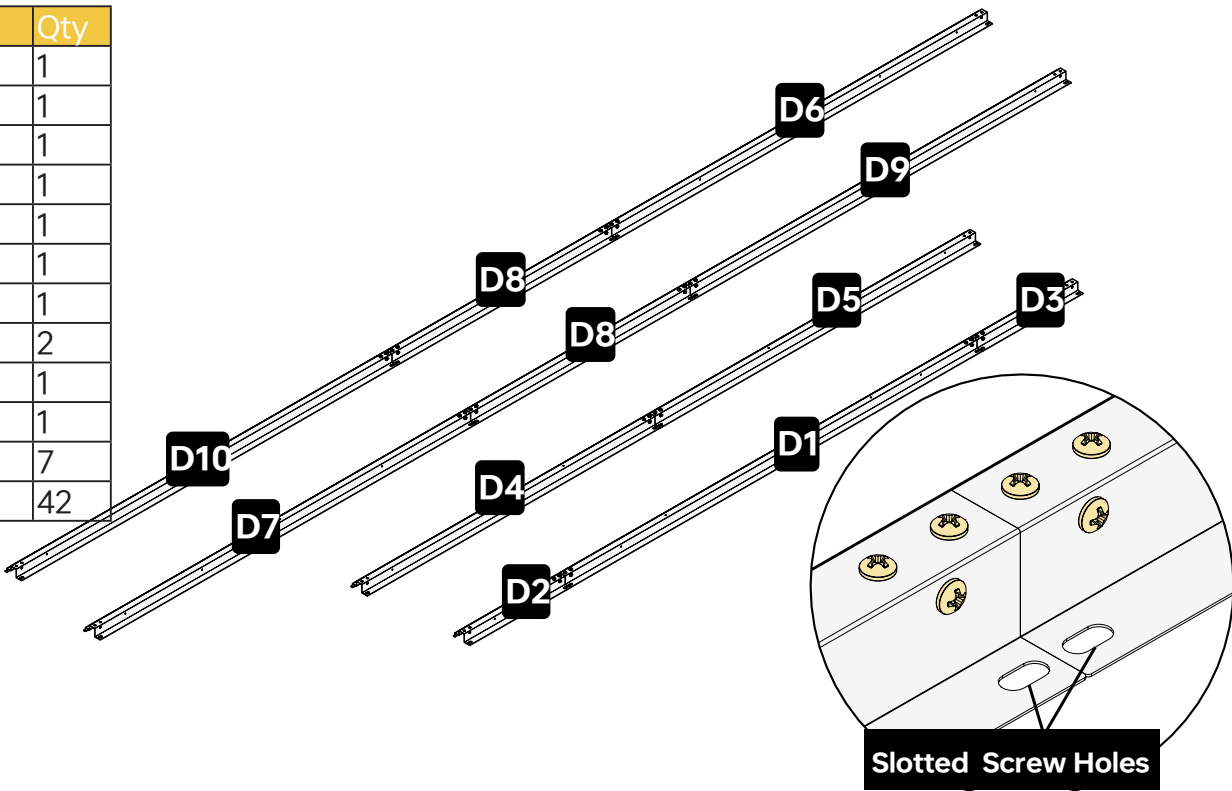

**NOTE**

When connecting D1~D10 frames, make sure  
 a) you are positioning them exactly the same as what's shown above and  
 b) the two slotted screw holes are in the front.

Two examples of incorrect layouts are shown below. Note that for the second mistake, even though D10 is placed on the left, the slotted screw holes are not in the front, so the placement is also incorrect.

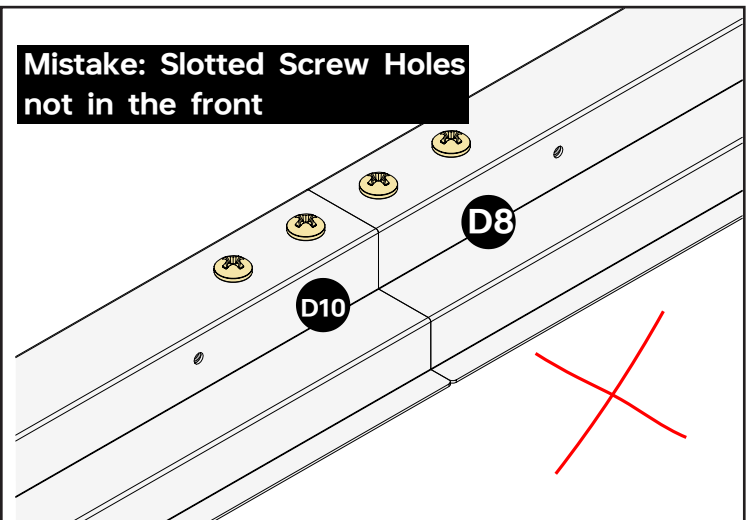
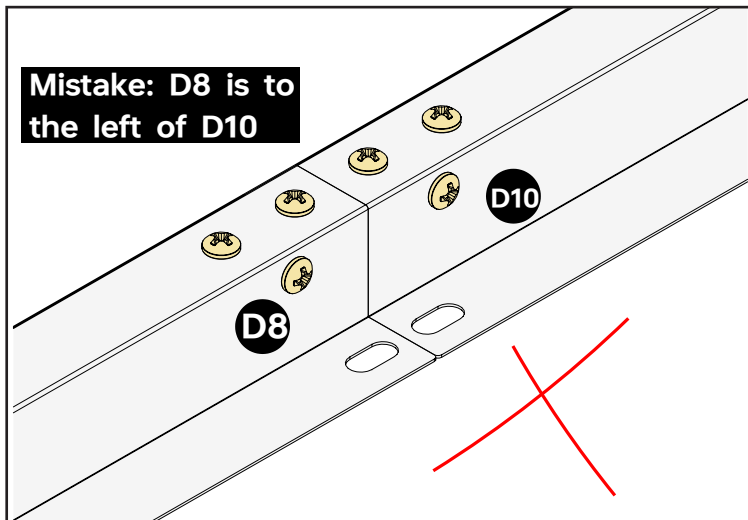

2

Part	Qty
A	4
A1	4
S3	32

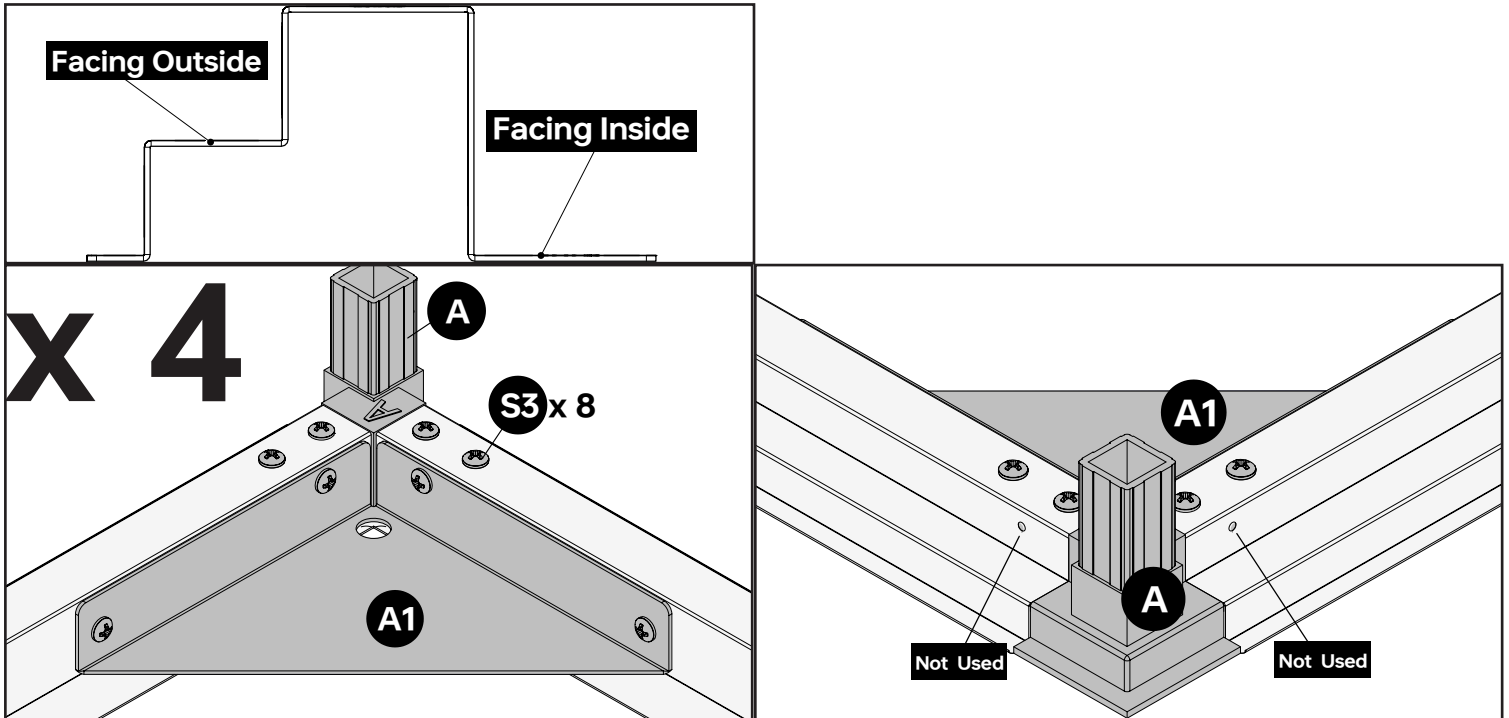
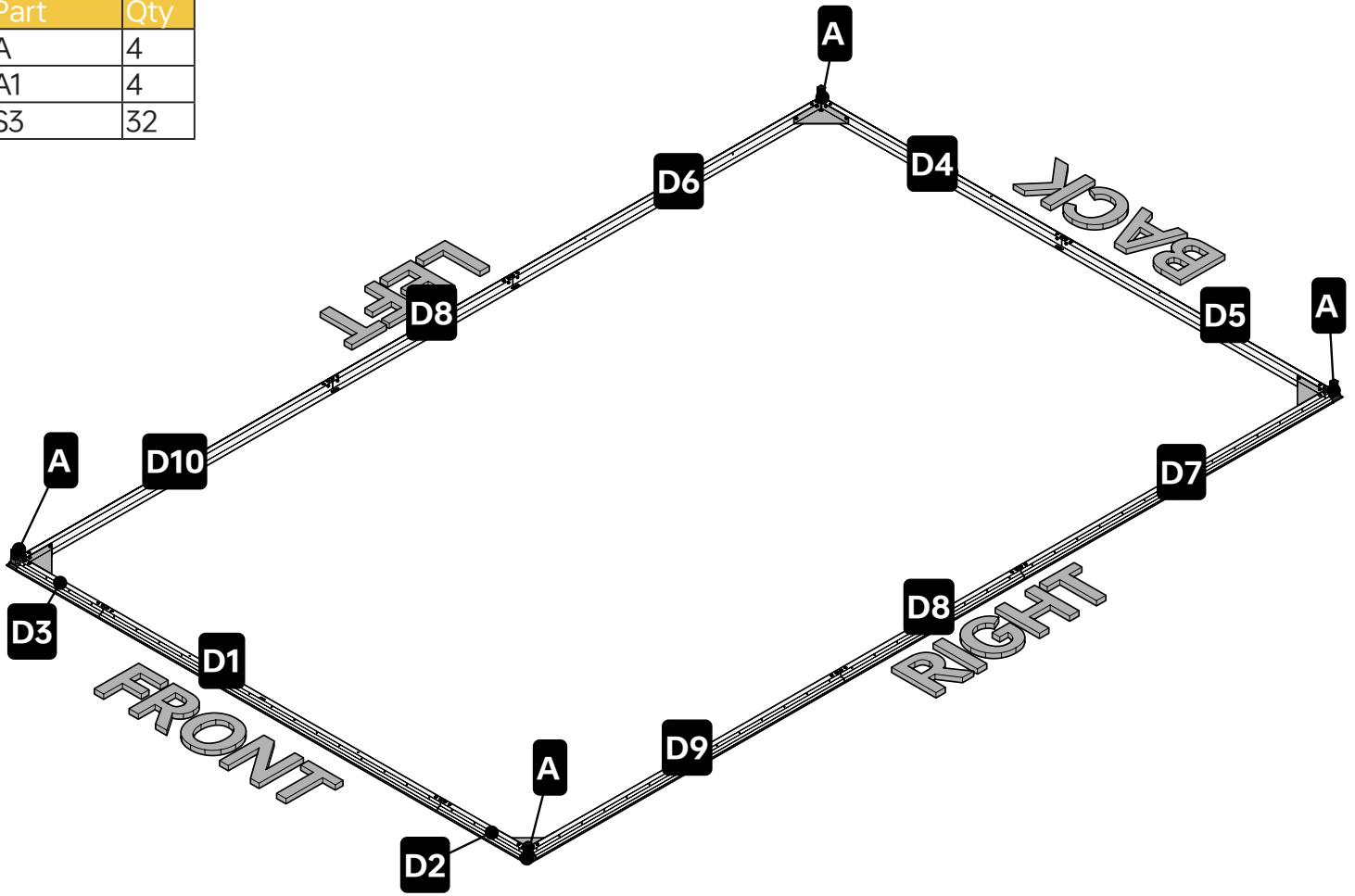

**NOTE**  
When placing D1~D10, note that they have a side that should always be facing outside. If you have problems positioning the frames like what's shown above, it's very likely that step 1 was not correctly followed.  
When screwing S3 into part A, do not use the two screw holes that are facing outside. They will be used in later step.

Part	Qty
N1	3
N2	6
S3	18

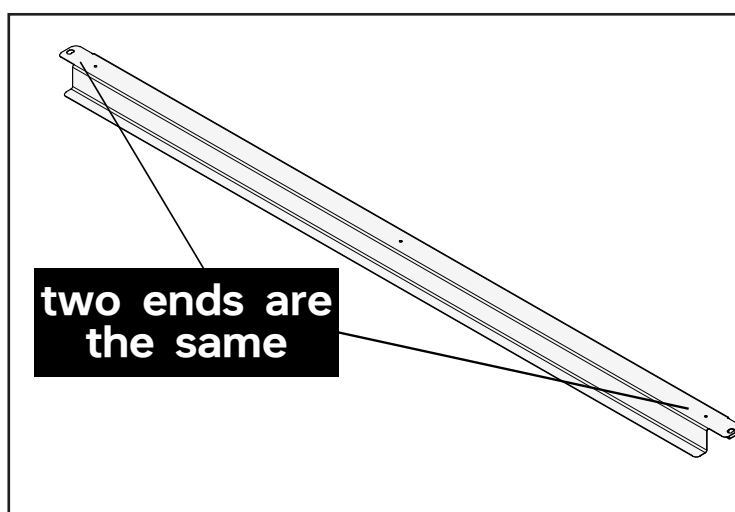
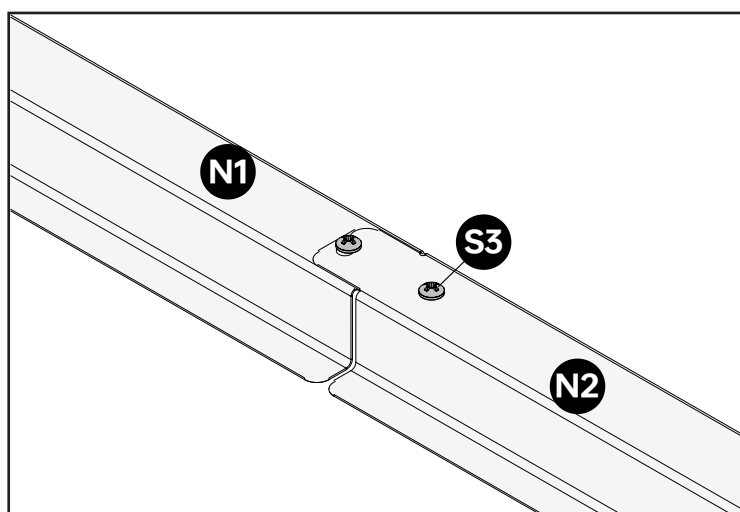
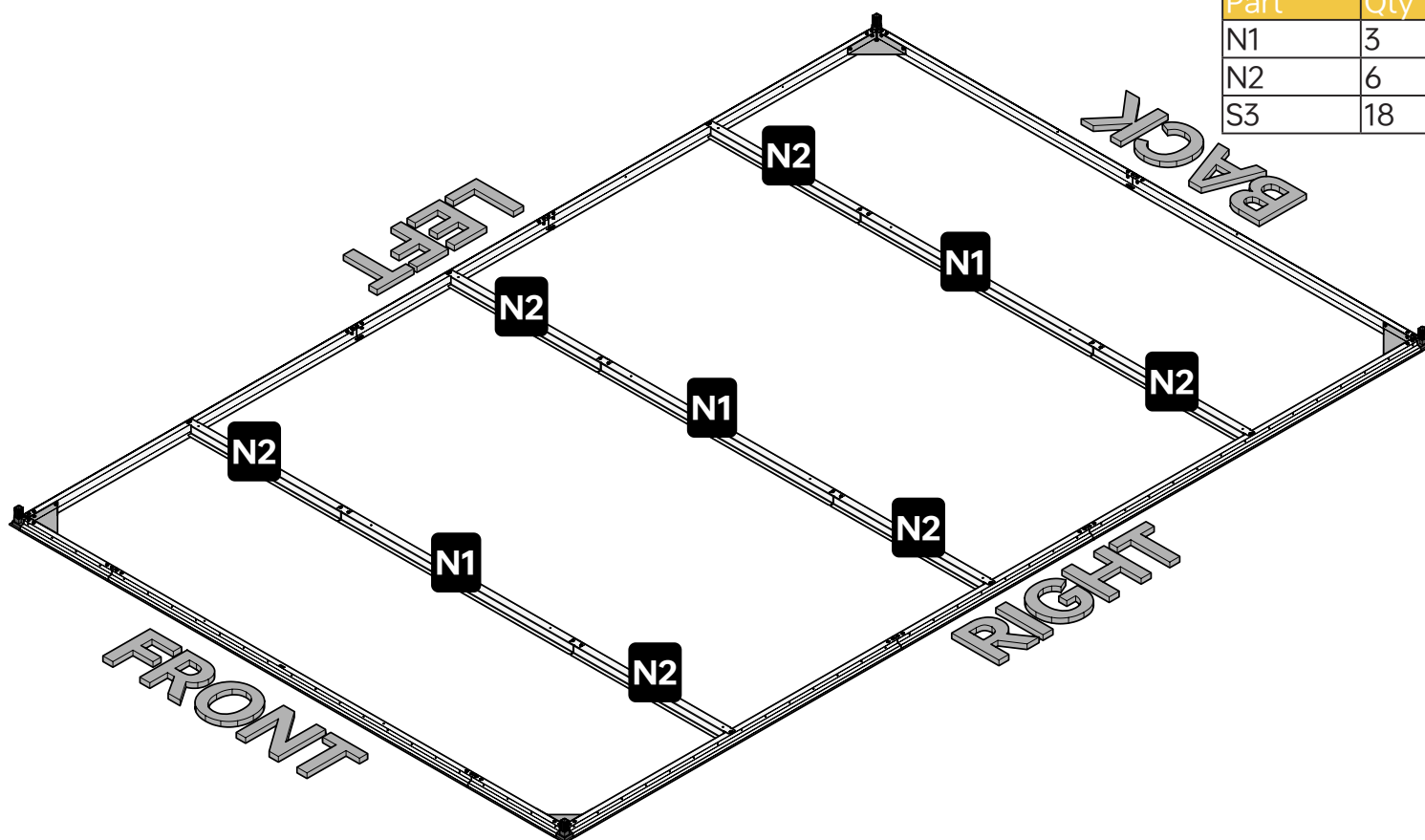

**NOTE**

Frames like N1N2 are symmetrical and you can use either end to attach to frames D1~D10. When N1 and N2 are stacked together, it does not matter which one is on top.

4	
Part	Qty
N3	4
N4	4
S3	10

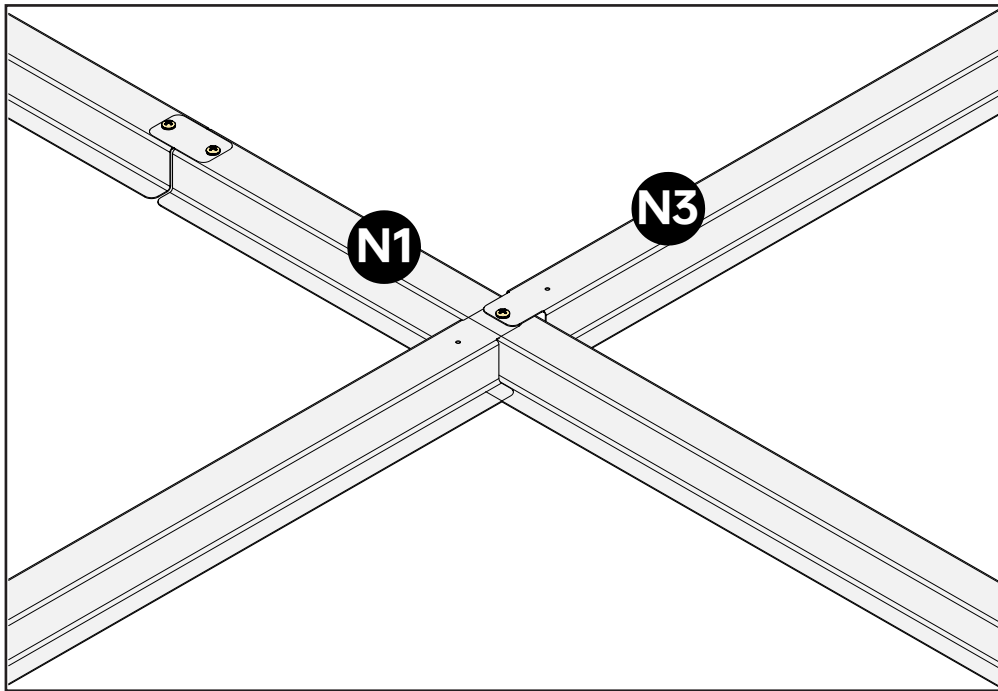
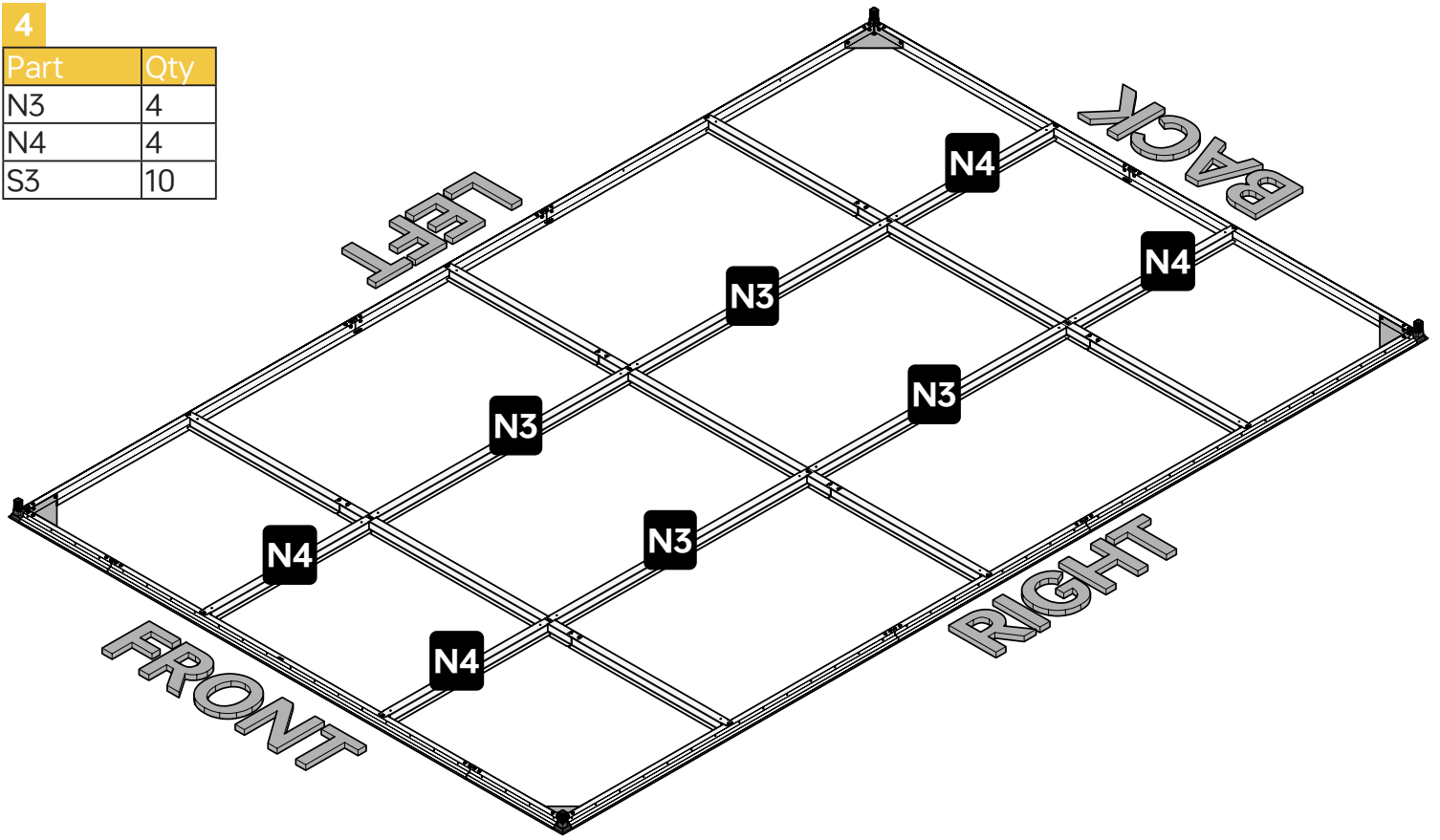

**NOTE**  
 Similar to last step, when N3 and N4 are stacked together, it does not matter which one is on top. There will be some screw holes left unused on N1~N4.

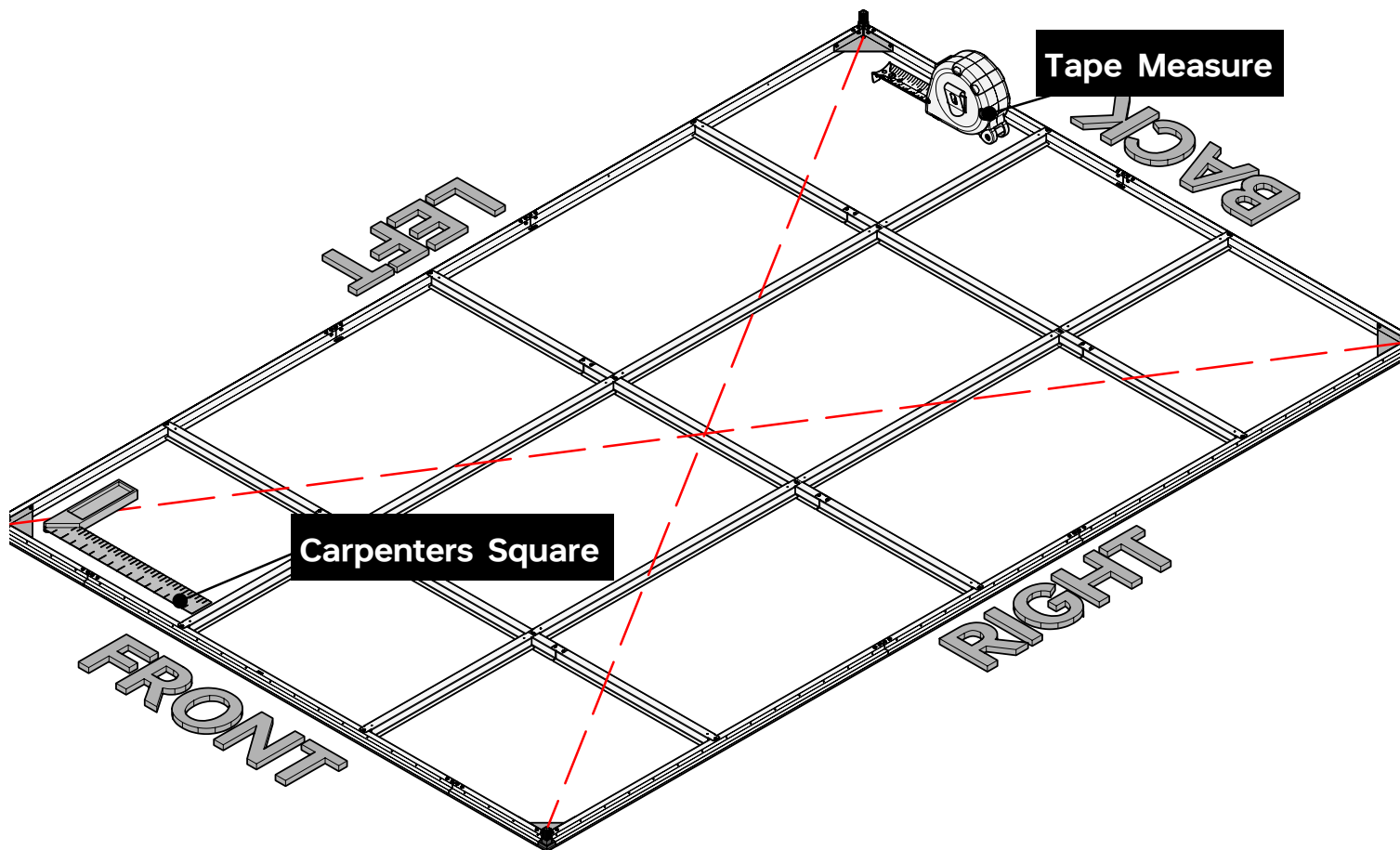

**IMPORTANT**

After the base frames are fully assembled, use a carpenter square to check that the four corners are square. Use a tape measure to check that the two diagonal lines of the frames are of the same length. Adjust the connection between D1~D10 and N1~N4 if the two diagonal lines have different lengths.

OPTION 1 ANCHORED TO CONCRETE FOUNDATION

6

Part	Qty
S6	4

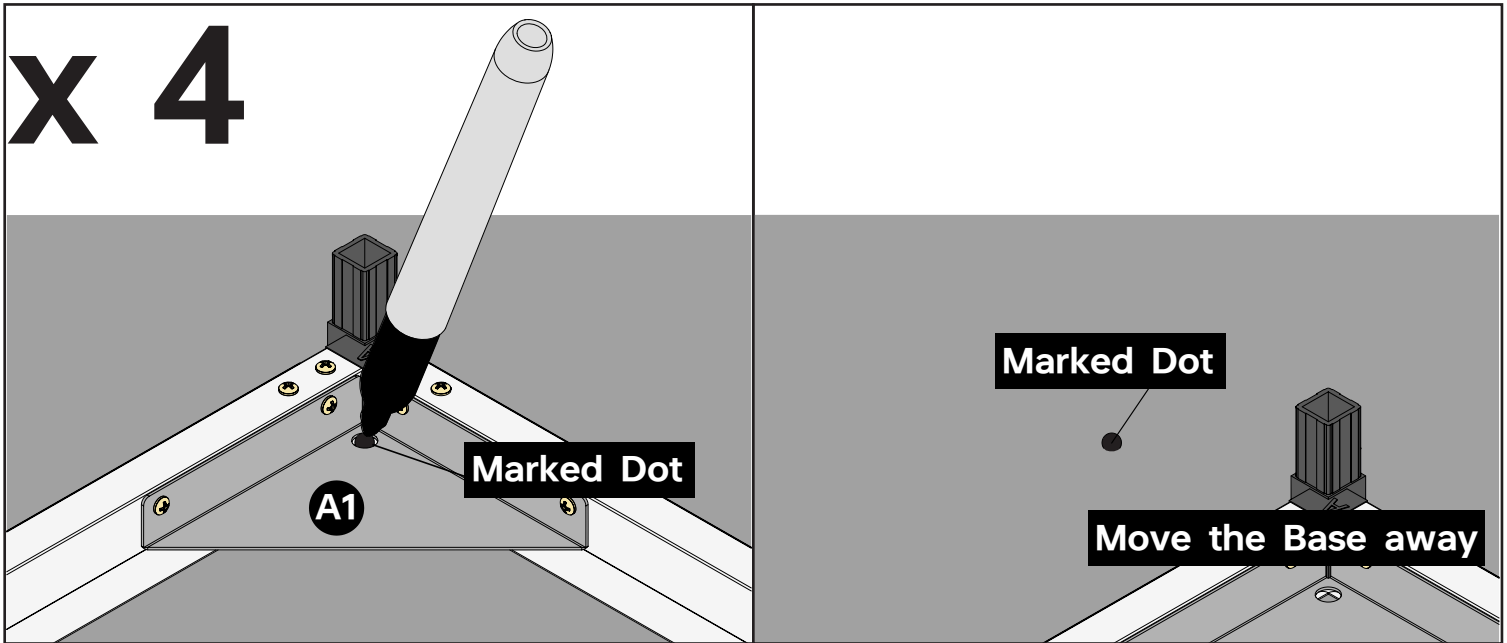
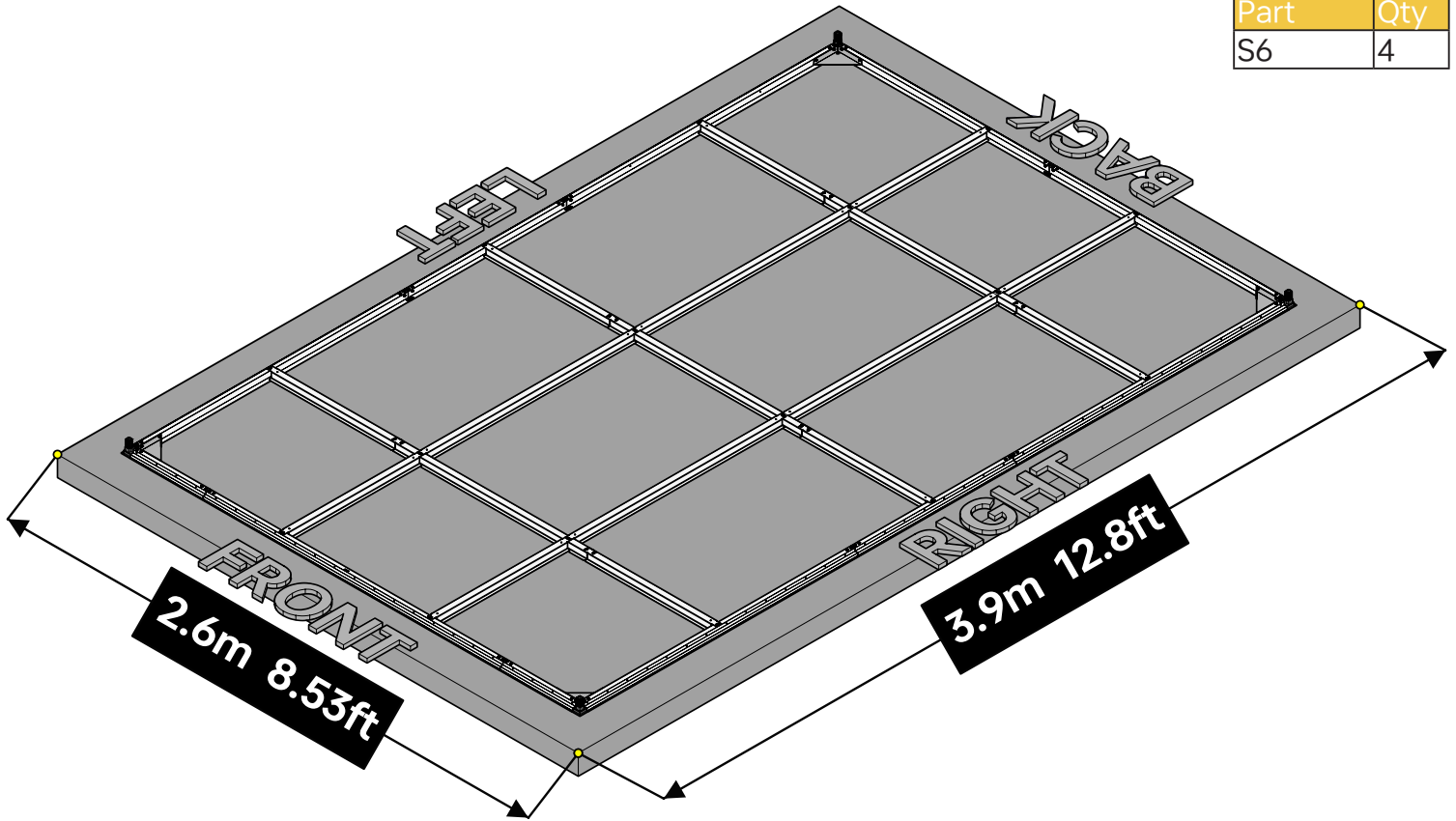

**NOTE**  
In each corner you will find a part A1 with a screw hole on it. Use a marker pen to mark a dot through the hole onto the foundation. Then move the base away.  
Continued on next page for this step.

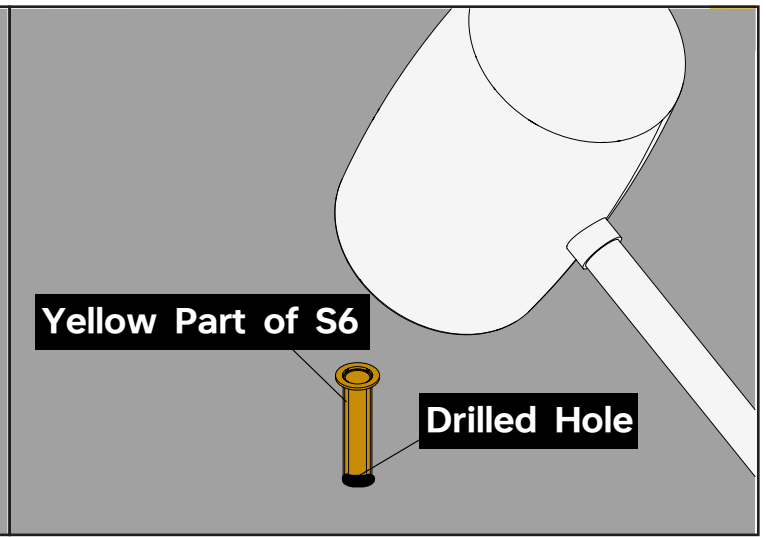
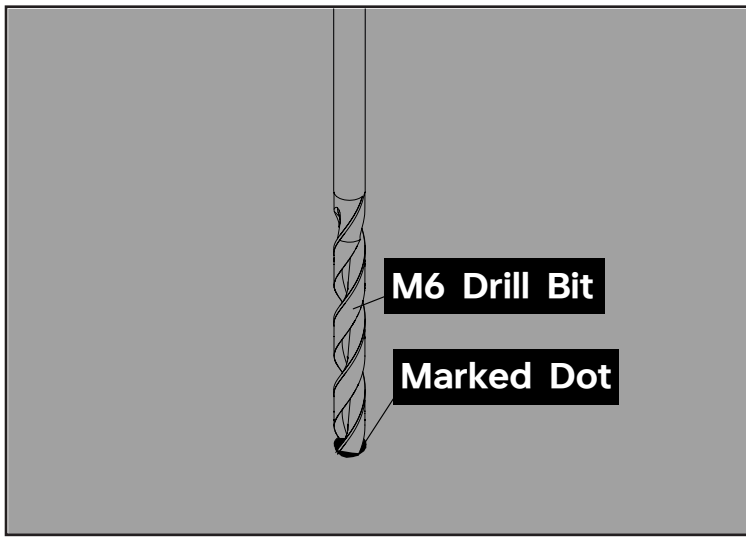

**NOTE**  
 Use a concrete drill with M6 drill bit to drill through the four marks. The drilled depth is 8cm (3.15inches). Use a rubber mallet to hammer the yellow plastic part of S6 into the drilled holes. Only use the yellow plastic part of S6 in this step. Do not use the screws of S6.

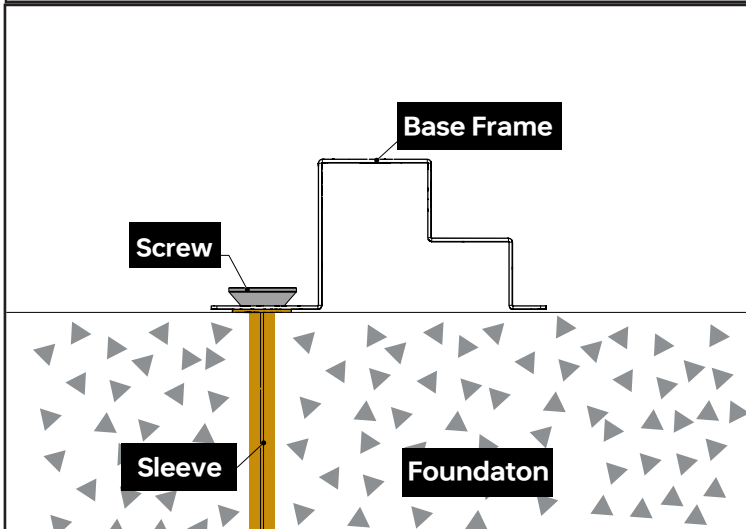
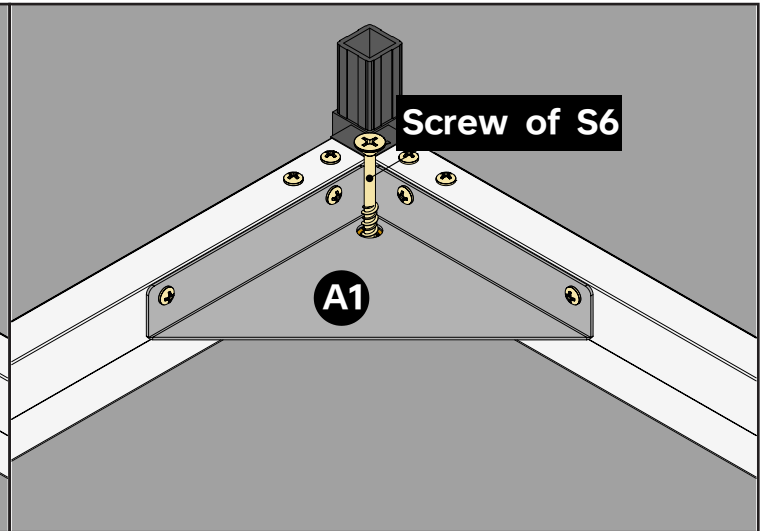
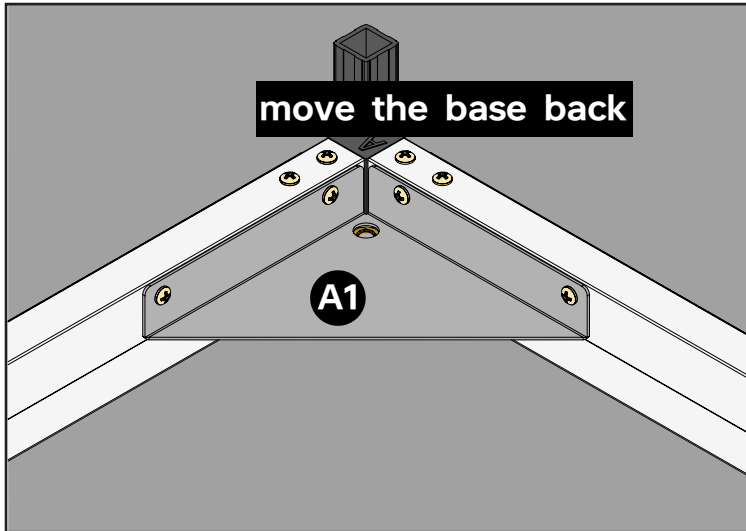

**NOTE**  
 Move the assembled base back onto the foundation and use the screw part of S6 to secure the frame to the foundation.

This concludes option 1.

## 7 OPTION 2 ANCHORED INTO GROUND

Part	Qty
S11	4

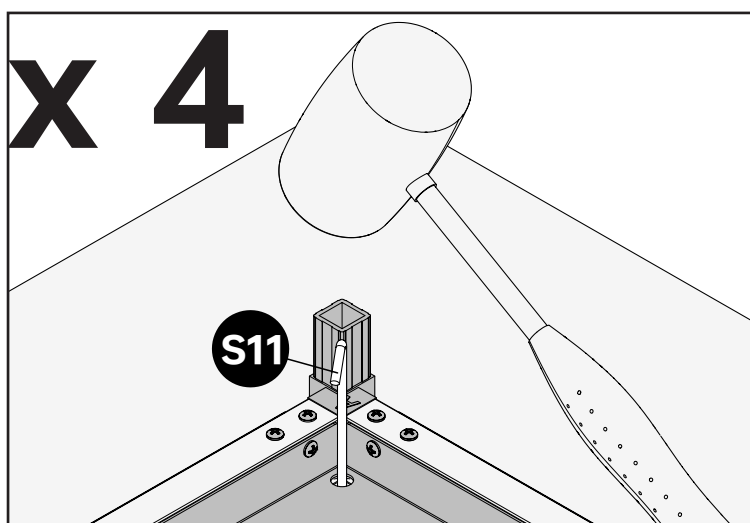
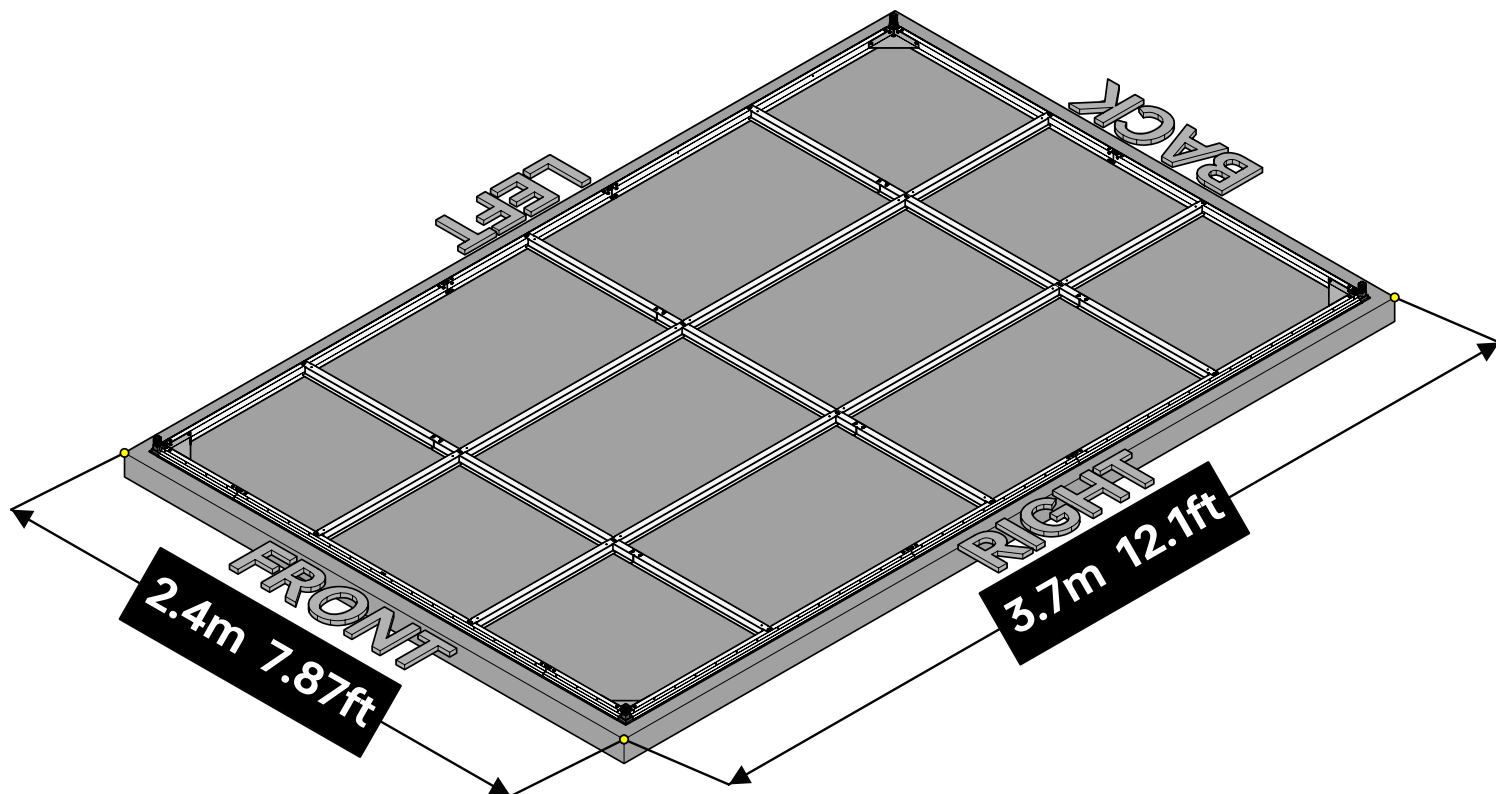

### NOTE

This garden shed occupies an area of 8.88m<sup>2</sup> (95.23ft<sup>2</sup>) on the ground, with a length of 2.4m (7.87ft) and a width of 3.7m (12.1ft).

This is the size of the roof and is larger than the size of the base frame.

You will still need a 0.91m (3ft) of clearance on all sides from walls or fences.

For this foundation option, all you need to do is use a mallet to hammer the S11 anchor to the ground.

This concludes the base chapter. Starting from next chapter, we will be demonstrating how to assemble the rest of the shed without showing the foundation.

# 05 Wall

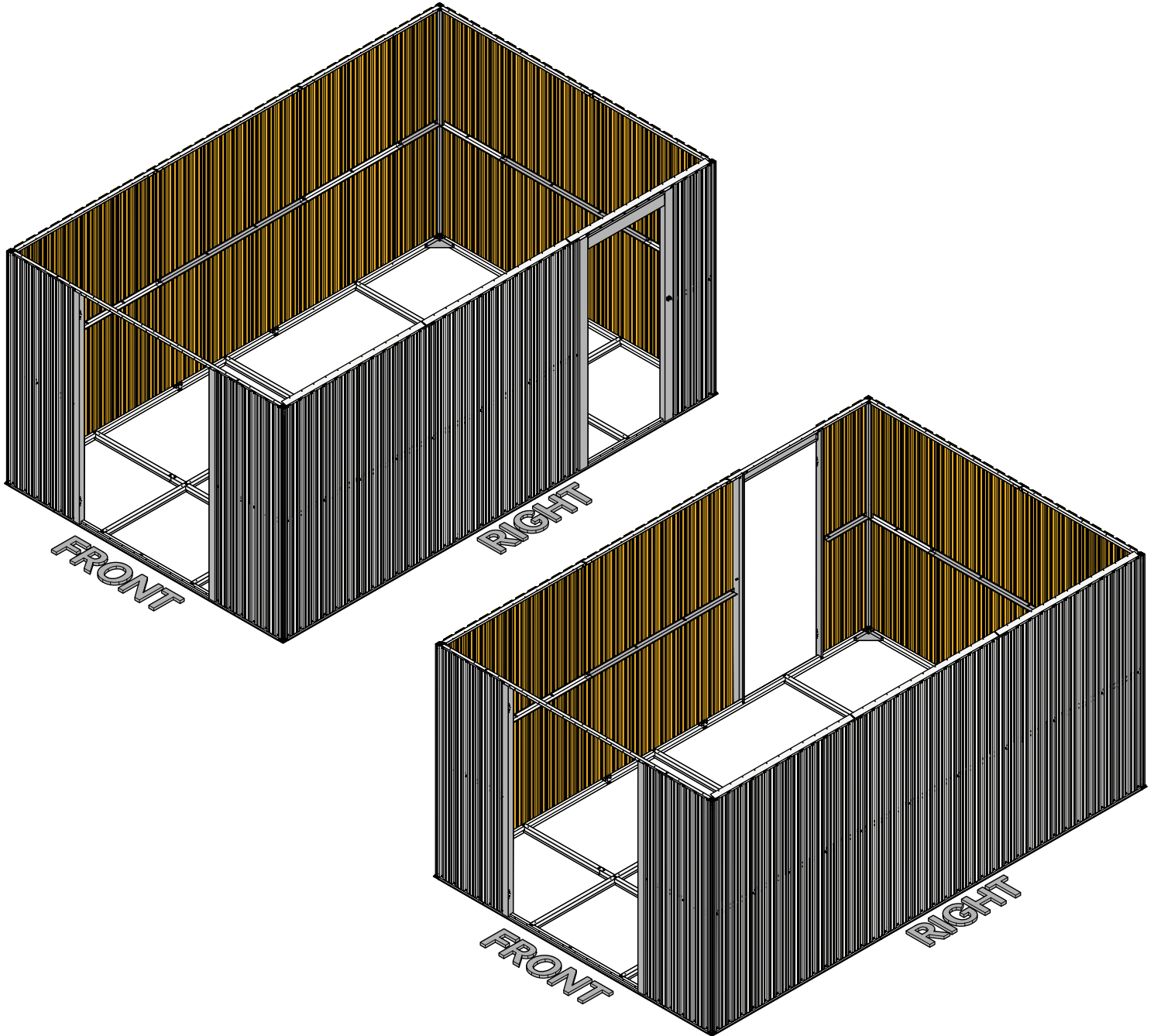

## IDENTIFYING THE INTERIOR AND EXTERIOR SIDE OF PANELS

Each panel of your shed comes with two distinct sides:

**Interior Side:** This side is always light gray, providing a uniform look inside your shed, regardless of the exterior color you choose.

**Exterior Side:** This is the side that showcases the color you selected for your shed, facing outward.

1

Part	Qty
QL	4

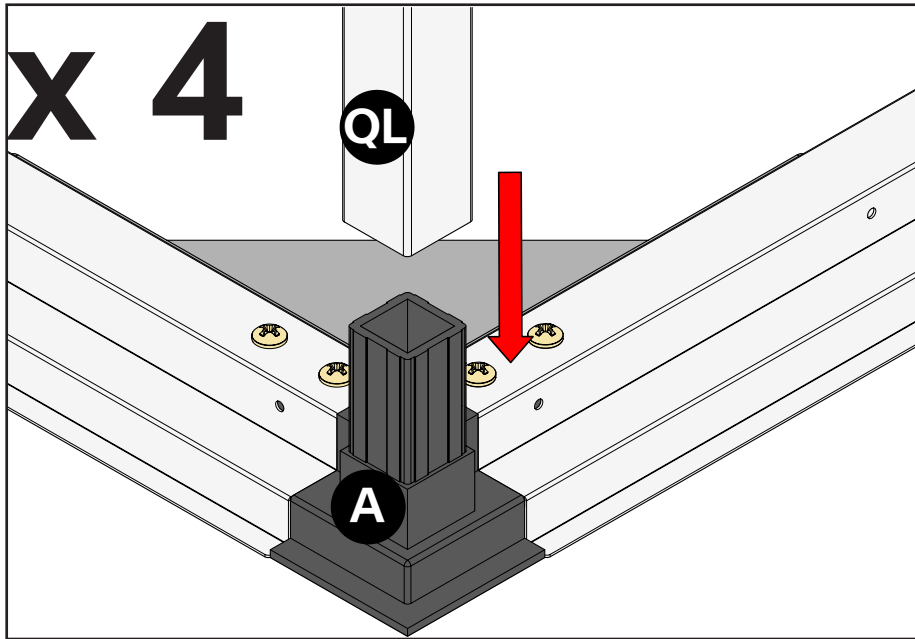
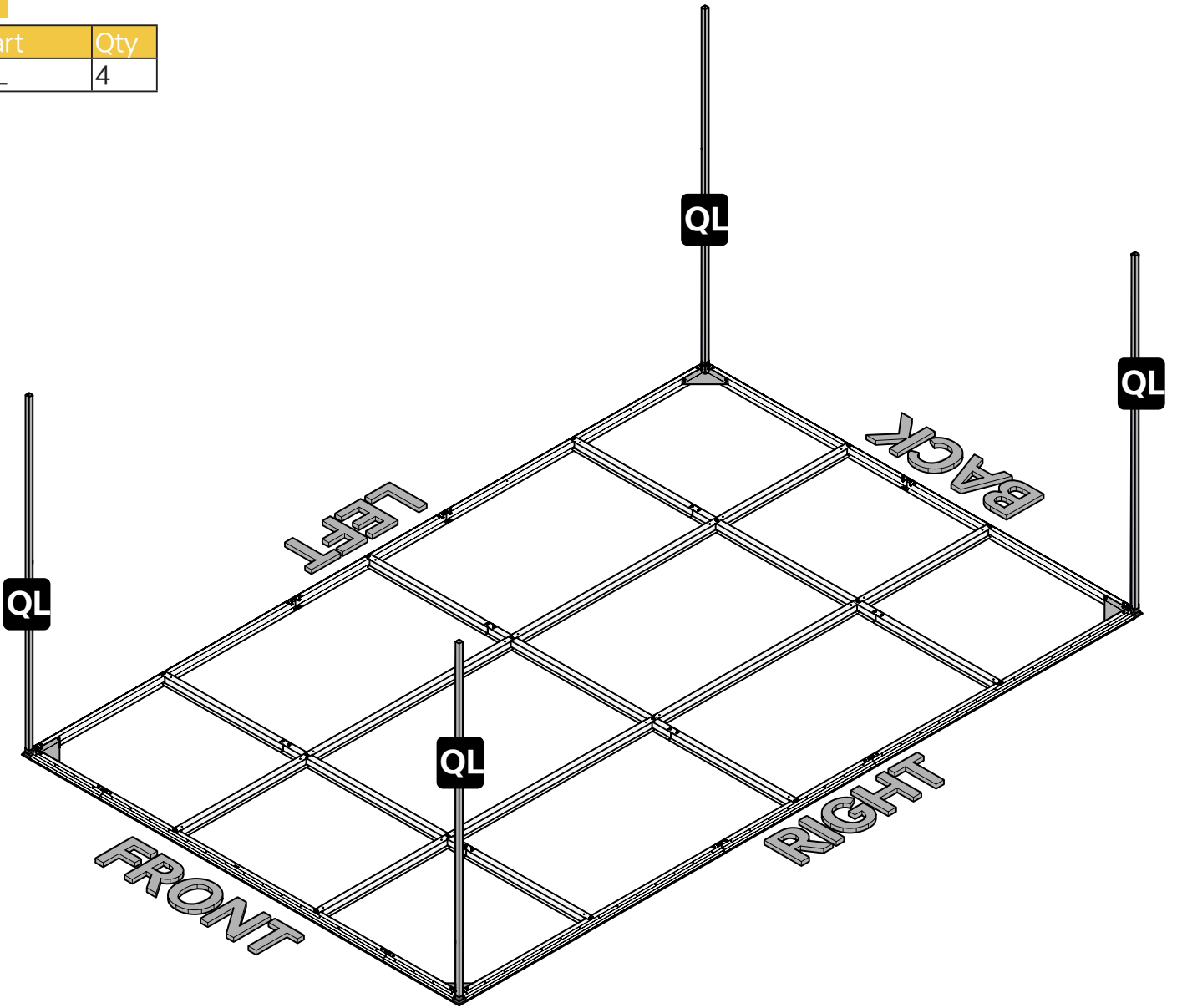

**NOTE**  
No screws are used when attaching QL to A. Also, you can attach either end of QL to A.

Part	Qty	Part	Qty
B2	1	B9	1
B3	1	B10	1
B4	1	B11	1
B5	1	C	7
B6	1	C1	7
B7	1	S3	14
B8	2		

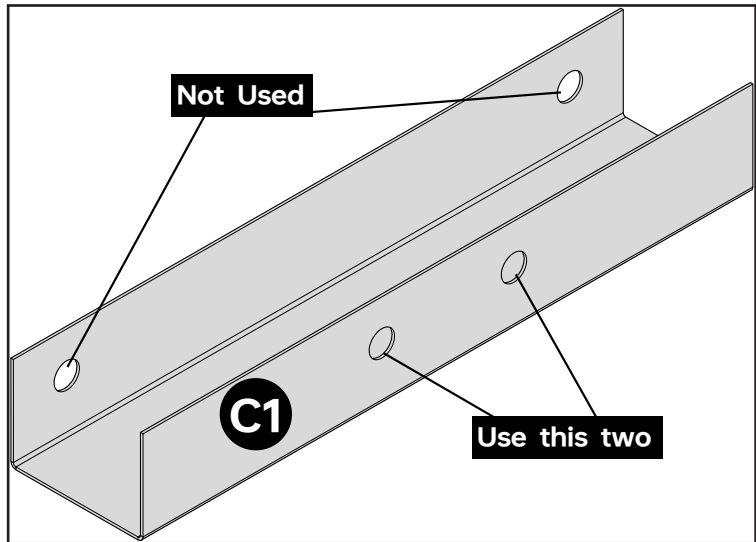
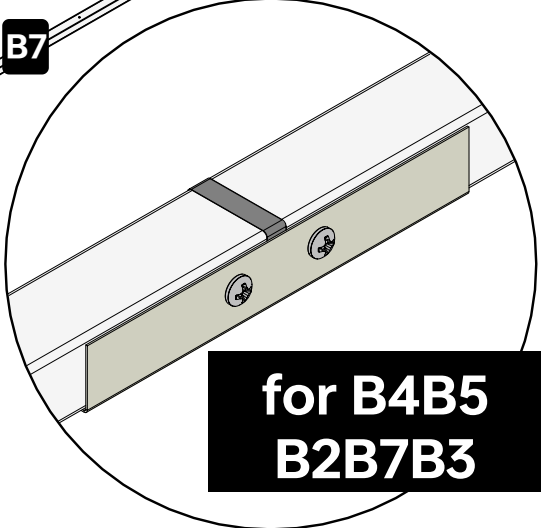
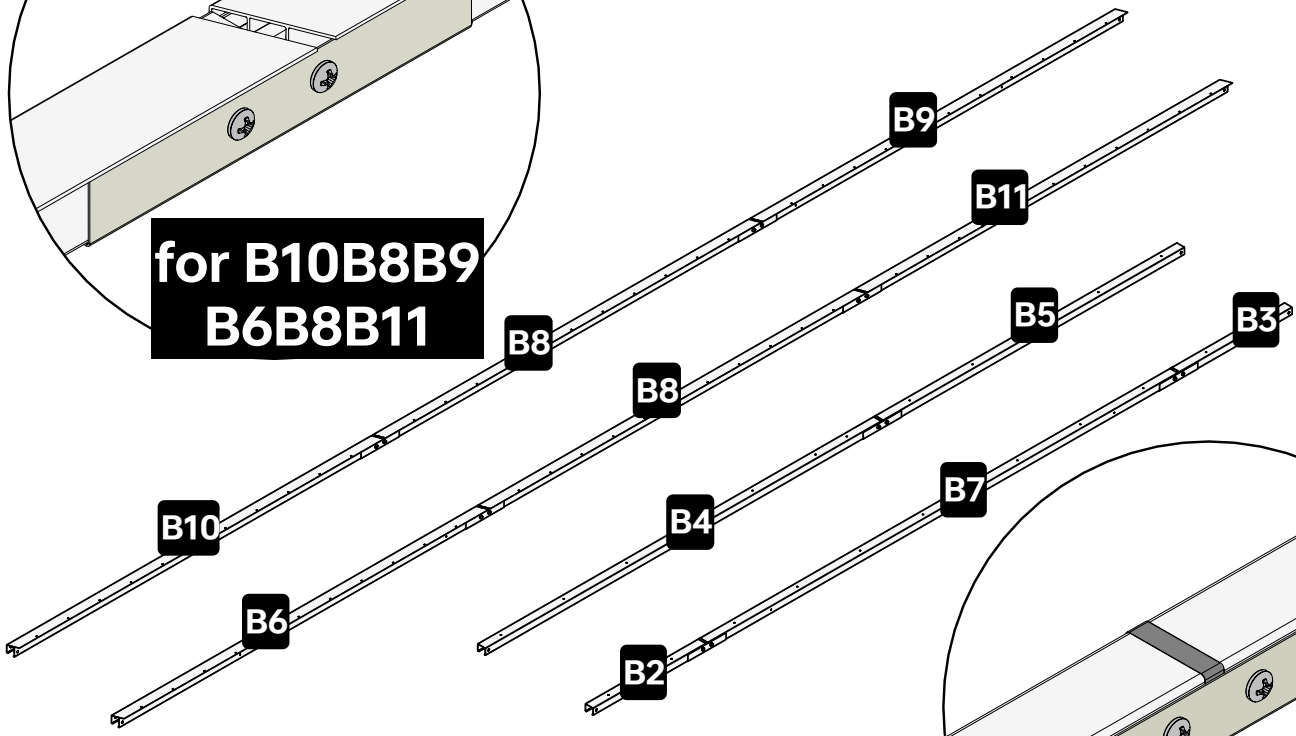
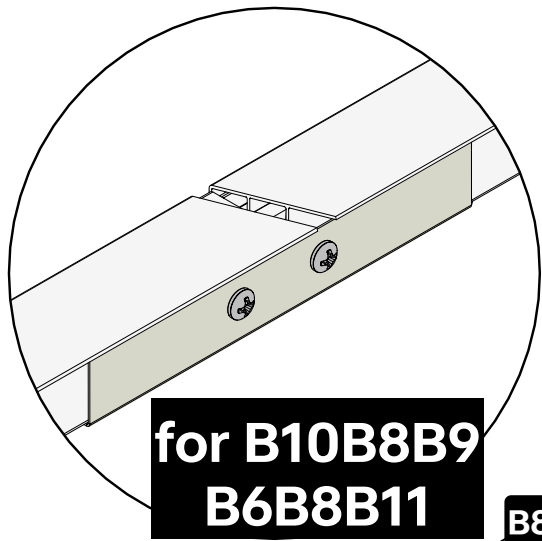

**NOTE**  
Continued on next page for this step.

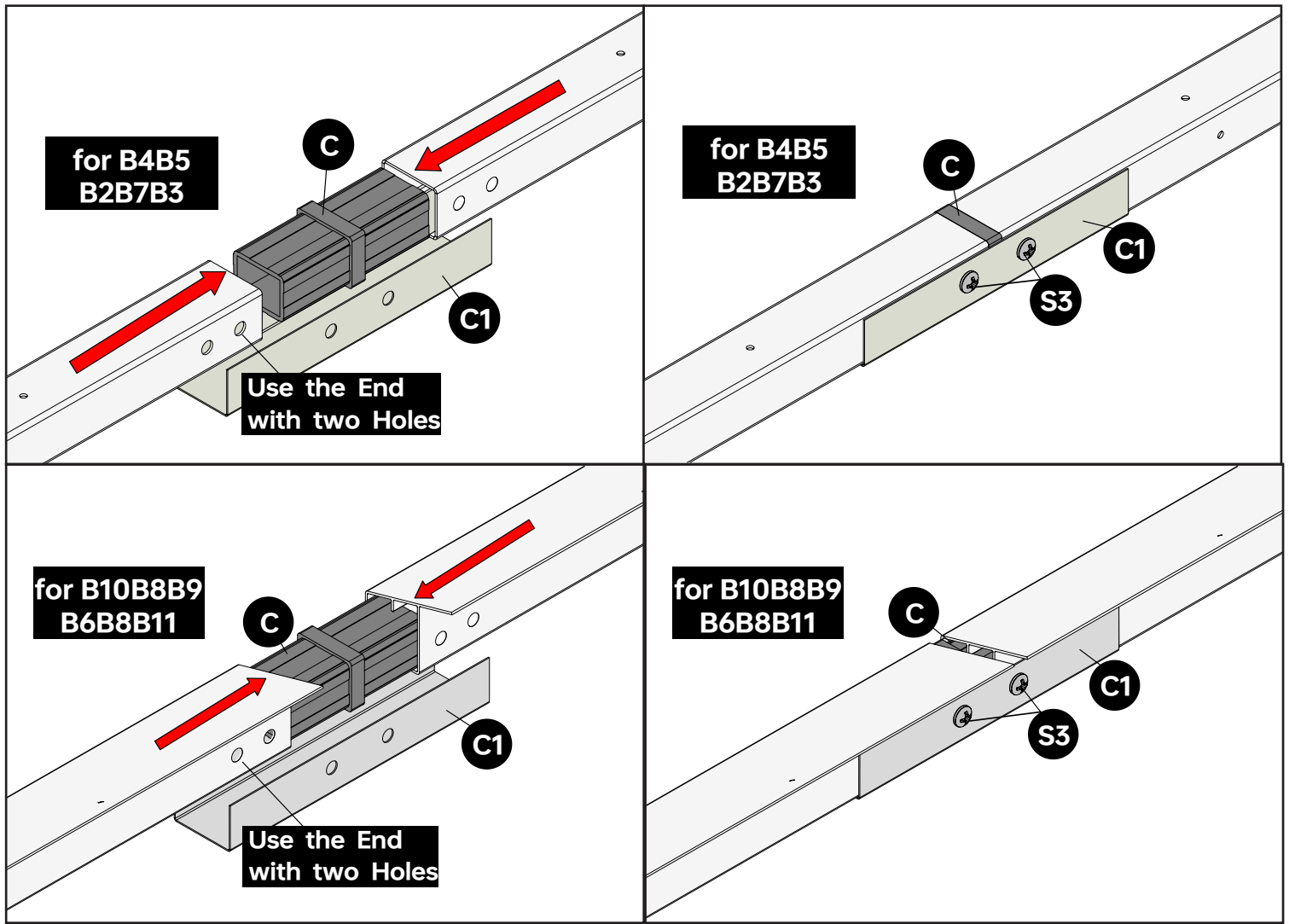

**NOTE**  
 Similar to step 1 in the base chapter, what's shown above is the only correct layout of connecting B frames. When connecting, use the end of B frames with two screw holes.  
 For C1, only use the two screws on one side. The two screw holes on the other side will be used later.

3

Part	Qty
B	4
S3	8

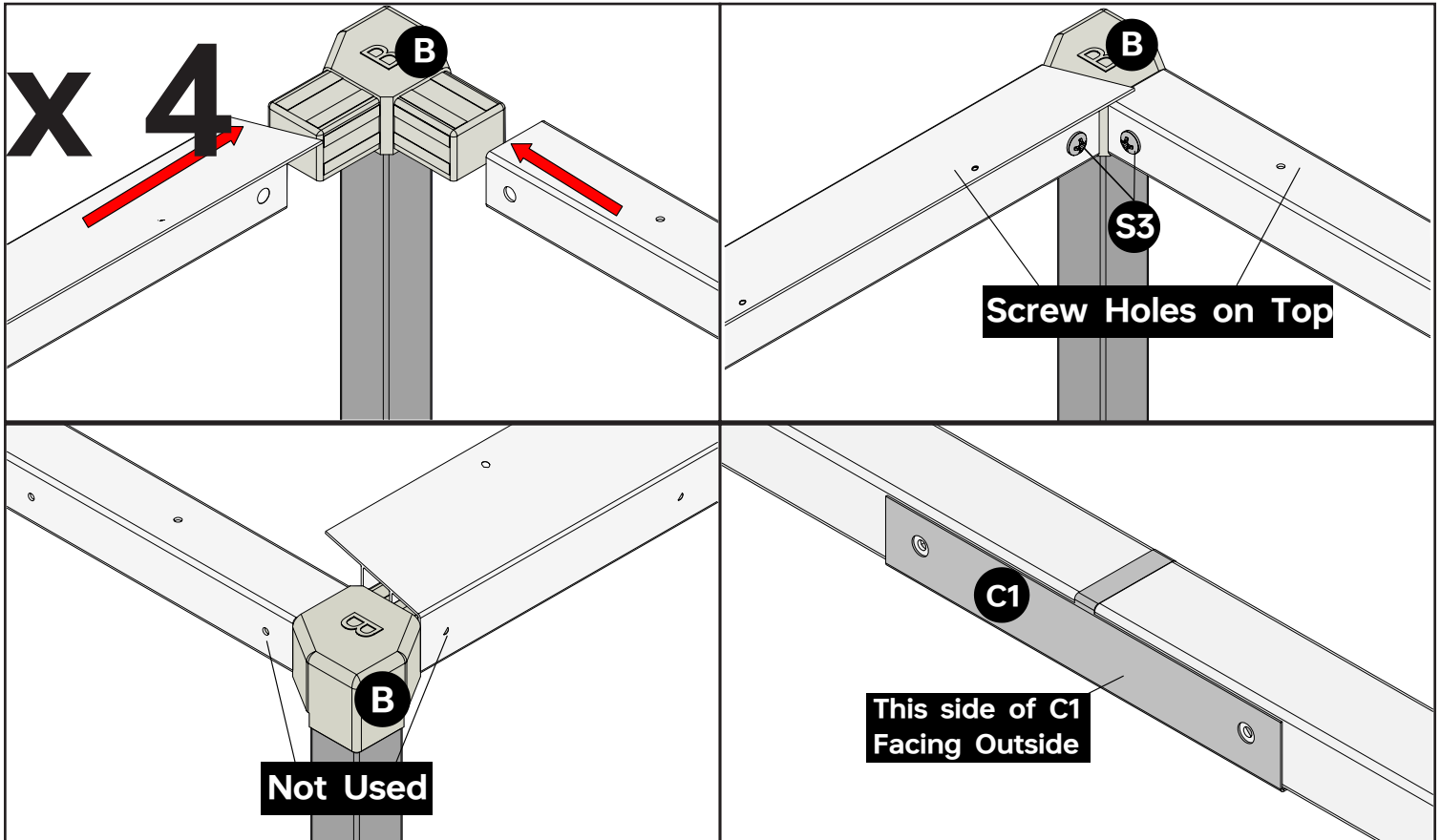
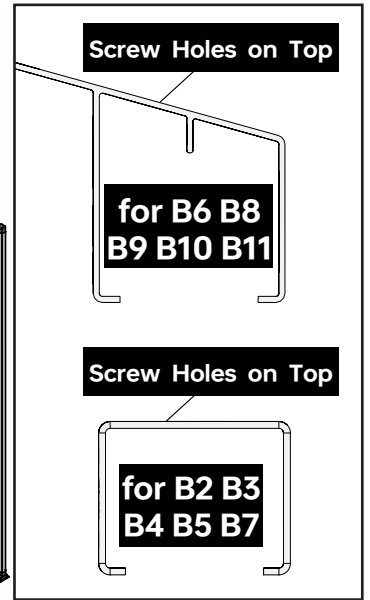
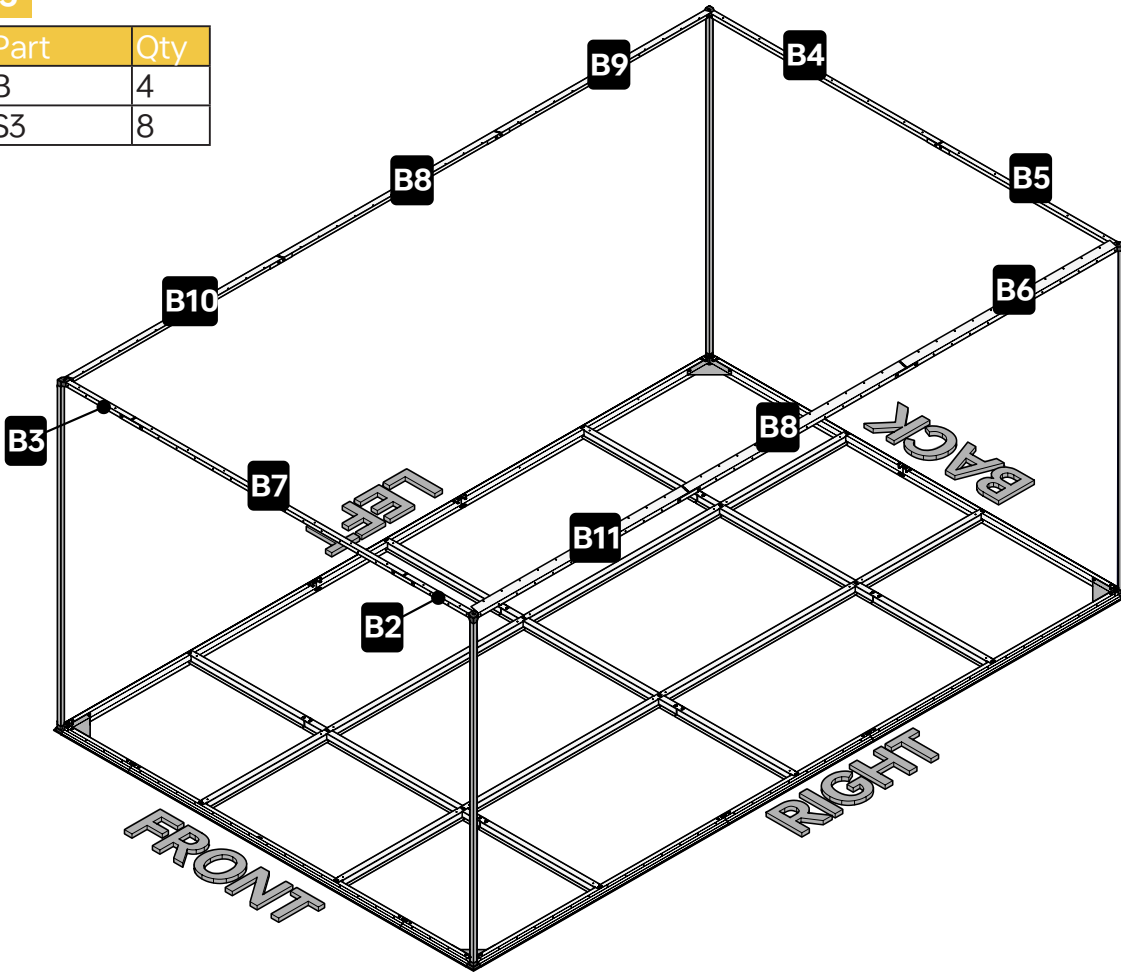

**NOTE**  
 When positioning B frames, make sure that the sides with no screws on C1 are facing outside and screw holes on top of B frames are visible to you.  
 For part B, do not use the two screw holes that are facing outside.

Part	Qty
Q4	4
S3	16
S4	16

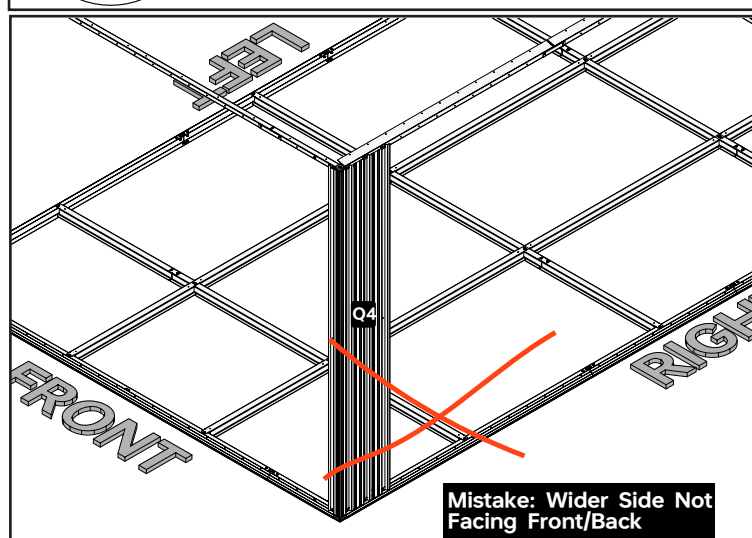
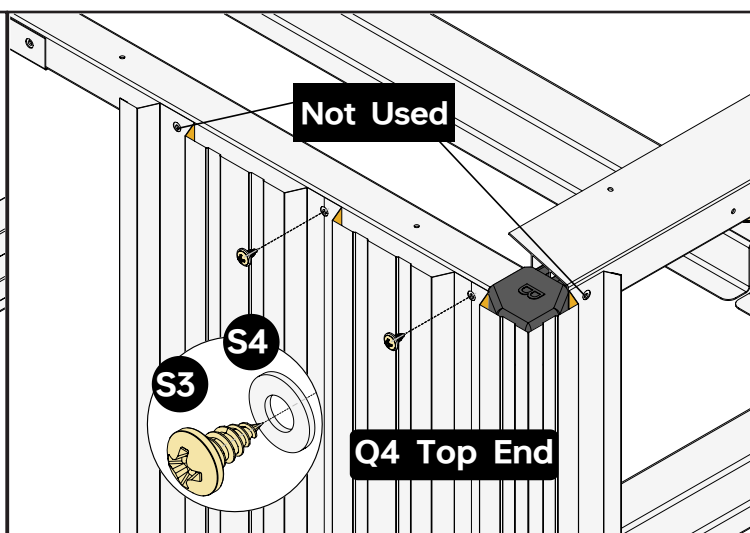
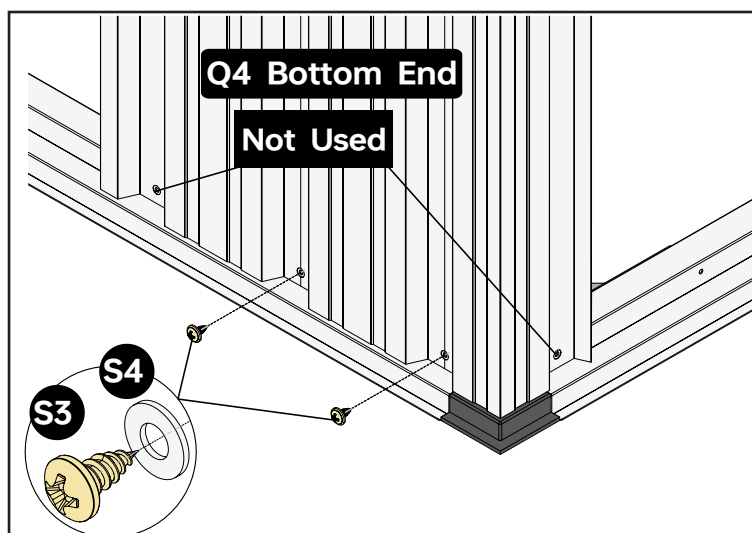
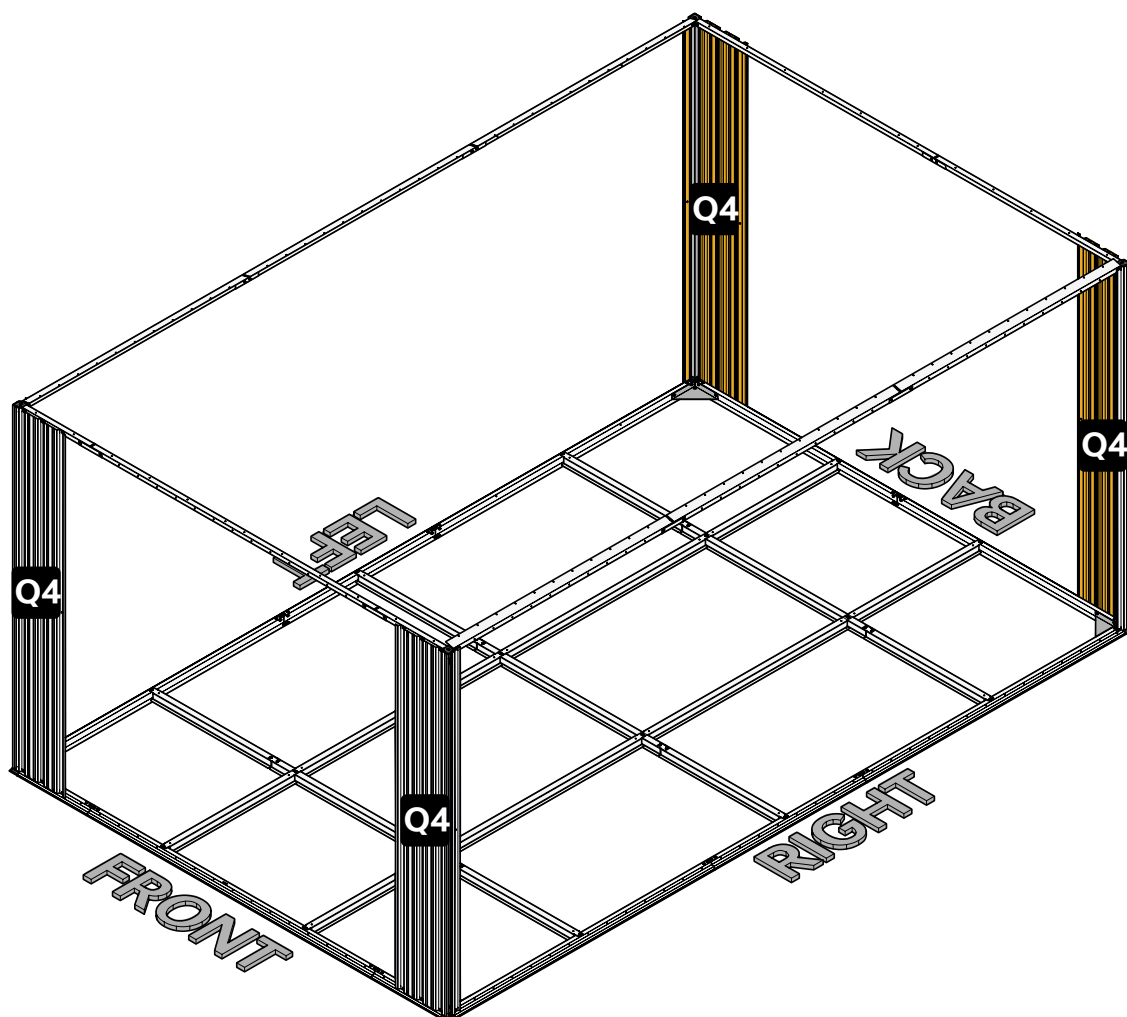

#### NOTE

When attaching Q4 to frames, make sure the wider side of the panel is facing front/back. The screw holes closer to the edge of each Q4 are not used in this step.

#### ABOUT THE PLASTIC WASHER S4

Use S4 with S3 to protect panels and rainproof the shed.

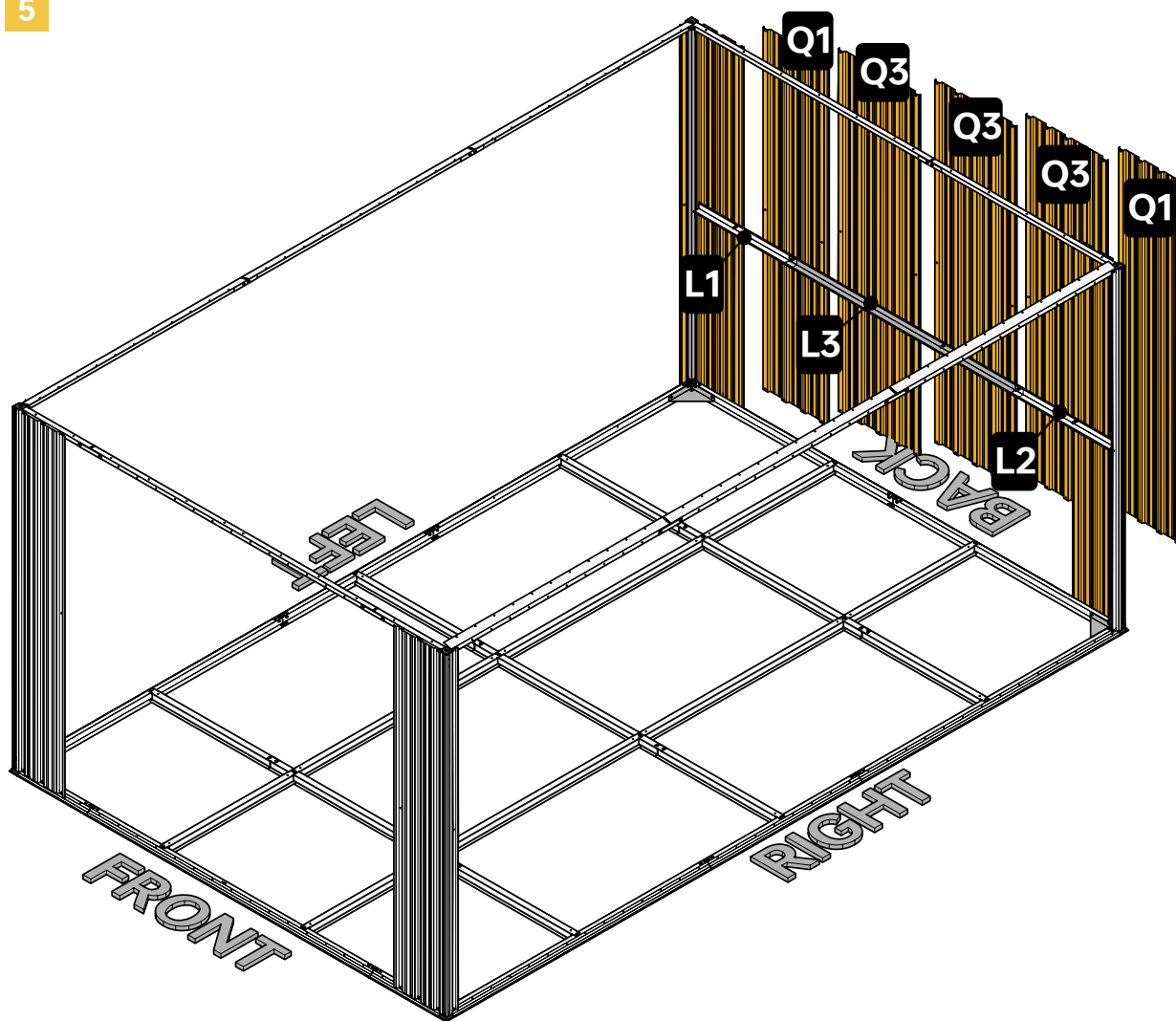

Part	Qty
L1	1
L2	1
L3	1
Q1	2
Q3	3
S1	6
S2	6
S3	38
S4	44
S5	6

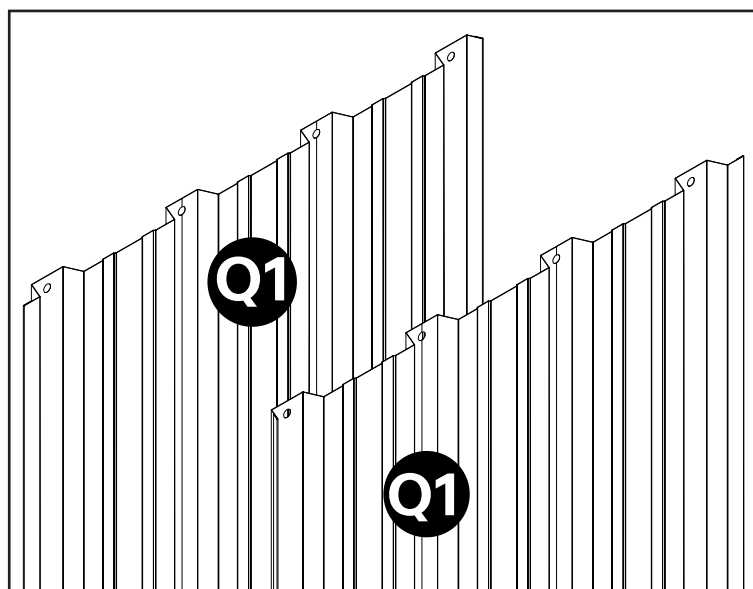

#### NOTE

##### WALL PANEL ASSEMBLY: Q1 AND Q3

For wall panel Q1, refer to the illustration on the left for two valid setup options. Don't worry about which end is up—Q1 works either way. Panel Q3 is symmetrical, so top and bottom ends are interchangeable as well.

##### QTY OF HOW MANY SCREWS WILL BE USED

From this step, the quantity of S3+S4 screws to be used on wall panels will not be shown in the illustrations. It will still be shown in the part/qty table.

This is to avoid cluttering the manual with unnecessary drawings.

Continued on next page for this step.

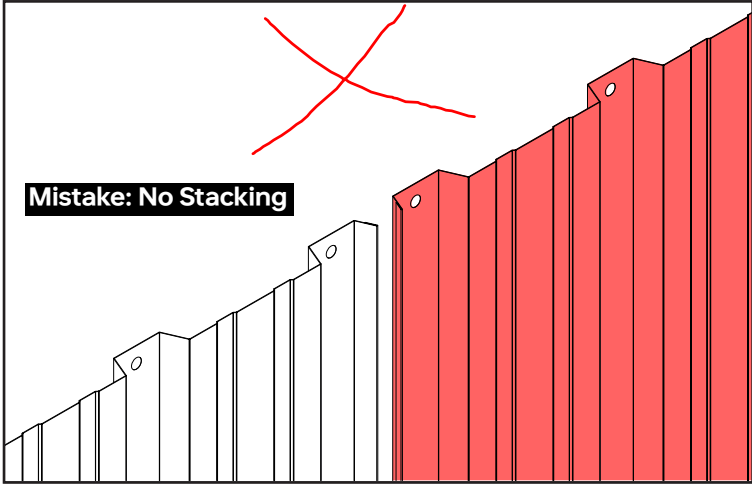
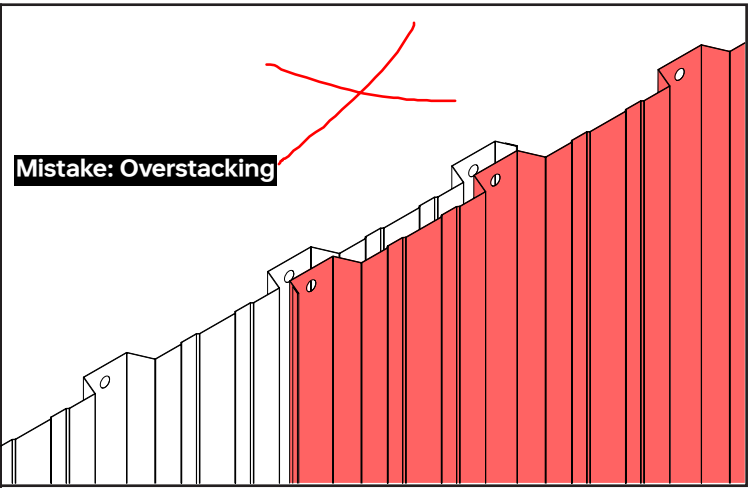
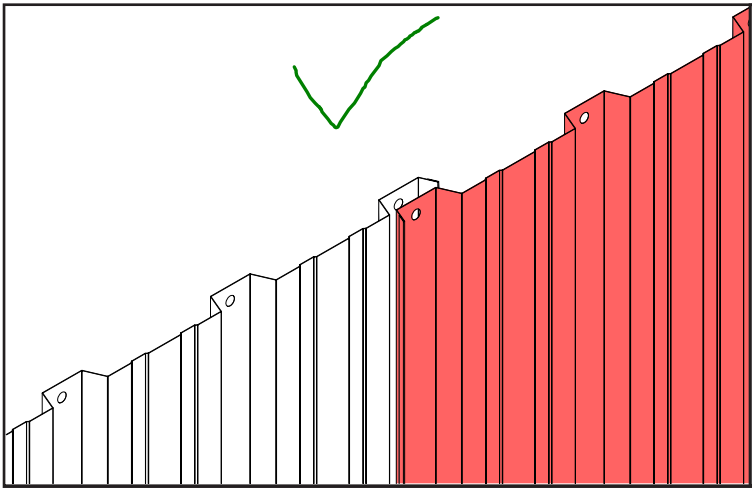

### ABOUT STACKING PANELS

The illustrations above demonstrate how to stack two panels. Note that, it does not matter which panel is layered on top.

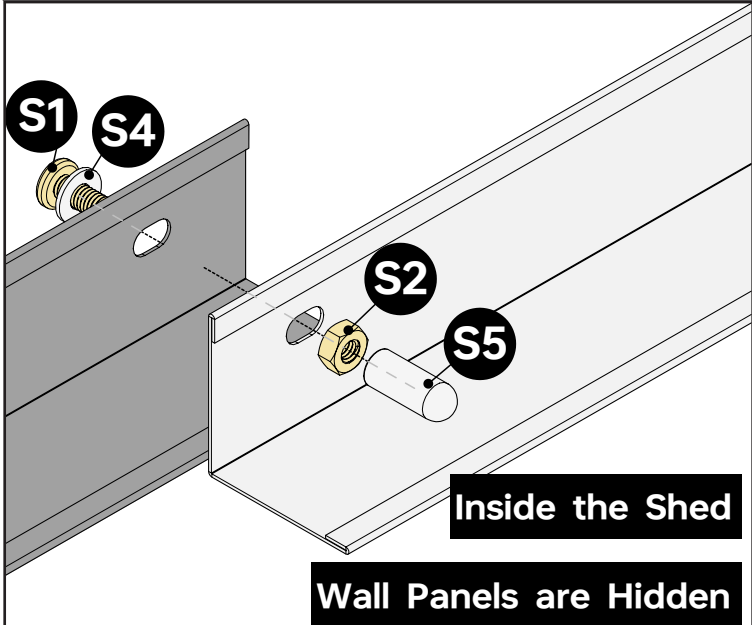

S5 is a plastic cap used with S1 and S3 to cover the pointy head of the screws. In this manual, we will outline some areas that we believe S5 is needed, but there are more S5 in the package than necessary.

The illustration on the left shows how L parts are stacked together. To improve readability, wall panels are hidden. Continued on next page for this step.

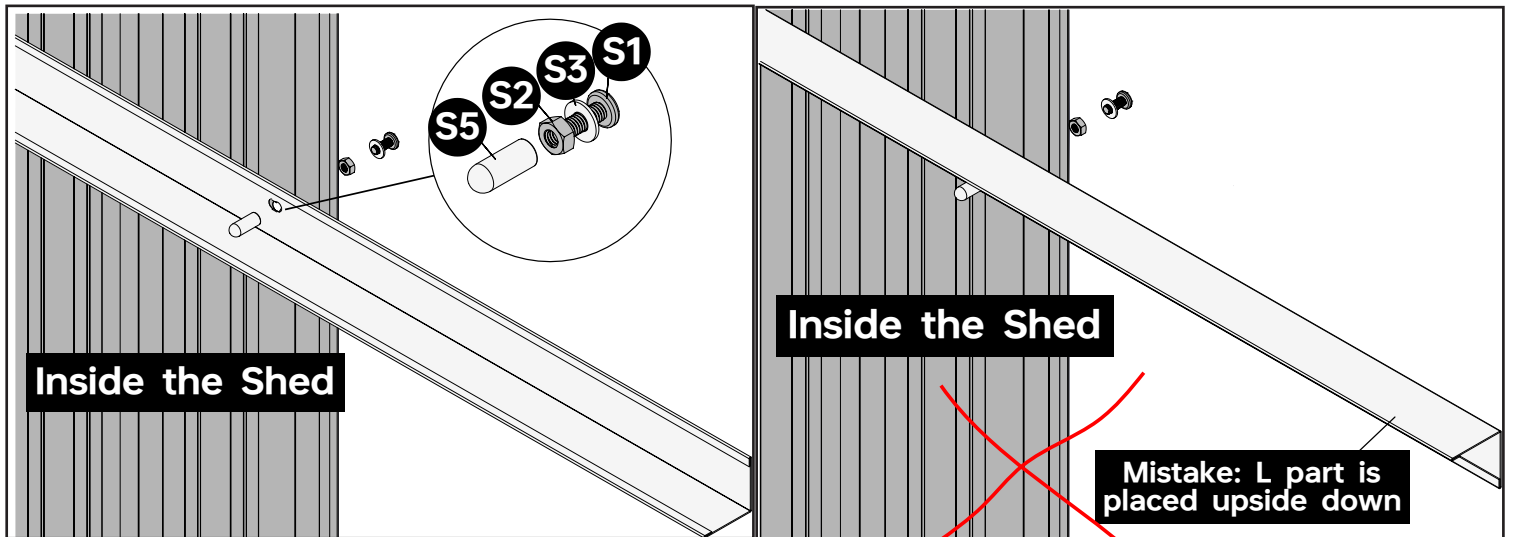
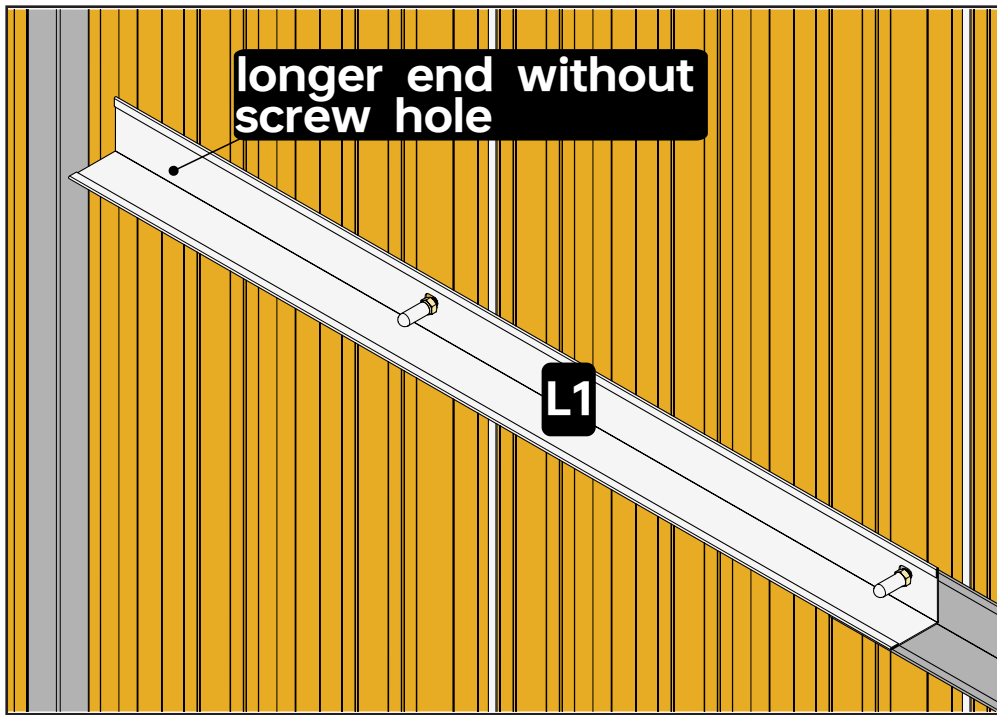

**NOTE**

The screw holes on L parts are corresponding to the screw holes on wall panels Q1~Q3. As a result, some L parts, like L1, have a rather long end that has no screw holes on it.

Note how the L part is placed.

Part	Qty
L1	1
L2	1
LL	1
LR	1
Q1	2
S1	4
S2	4
S3	22
S4	20
S5	4

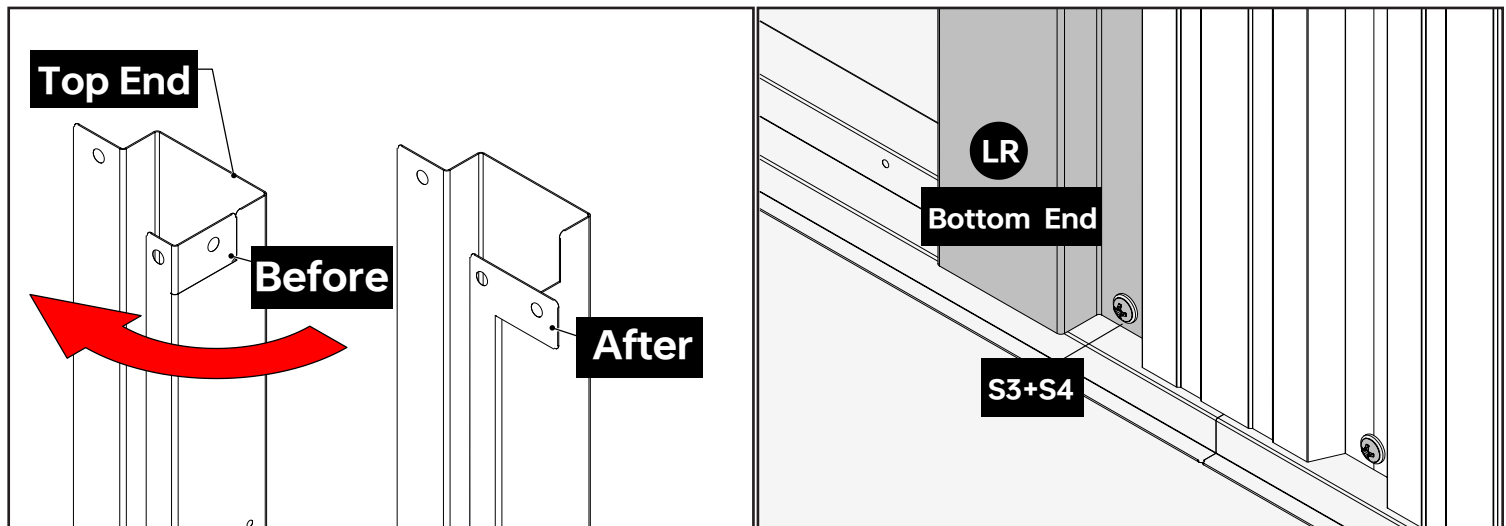
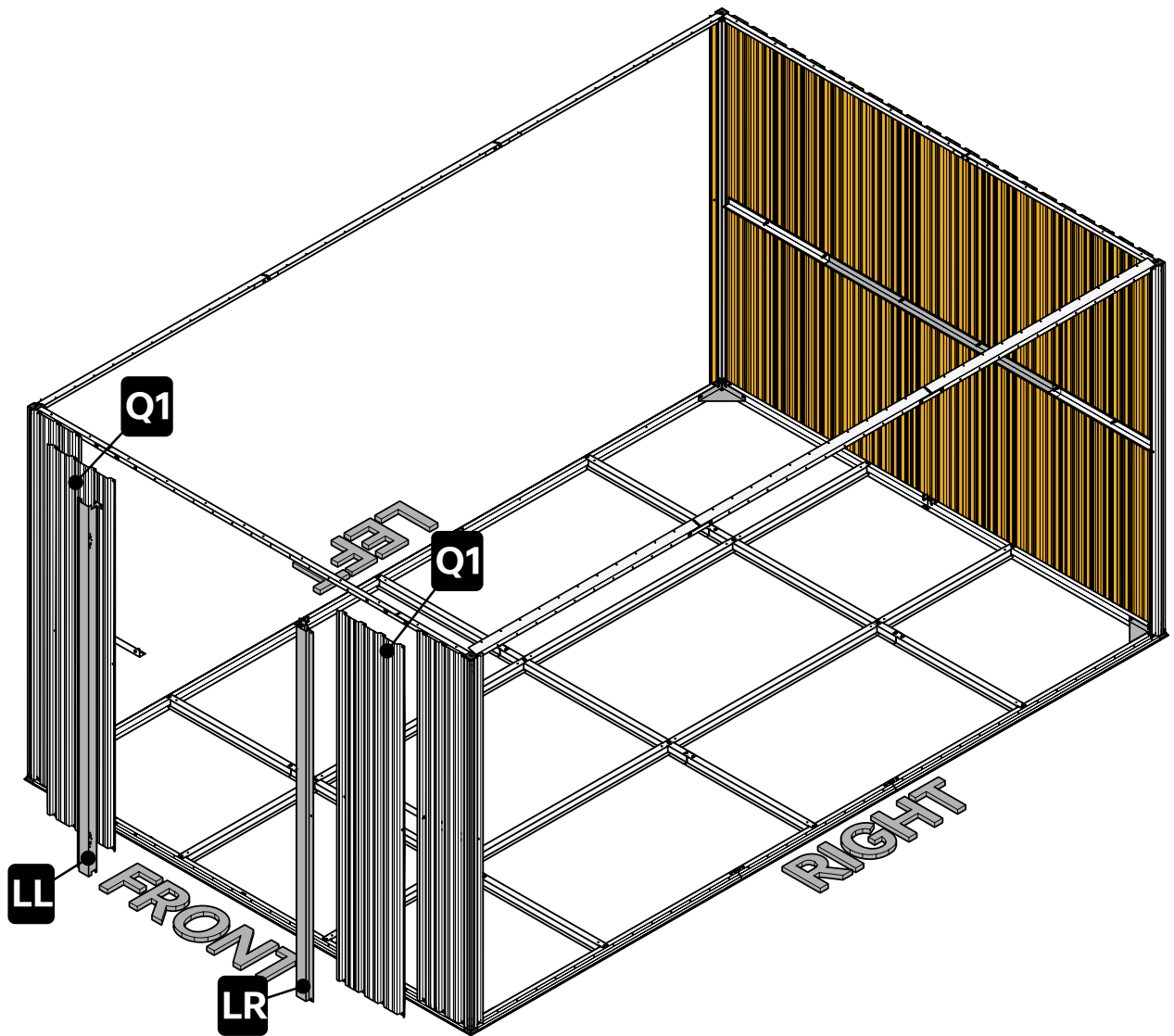
**NOTE**

LL and LR are stacked on top of Q1.

LL and LR have a top and bottom end. Do not mix them up.

Before using LL and LR, use a plier to bend the top end. This can also be done using your hand. Make sure your work gloves are solid enough.

In this step, we will only show how to attach LR to the shed but the steps are the same for LL.

Continued on next page for this step.

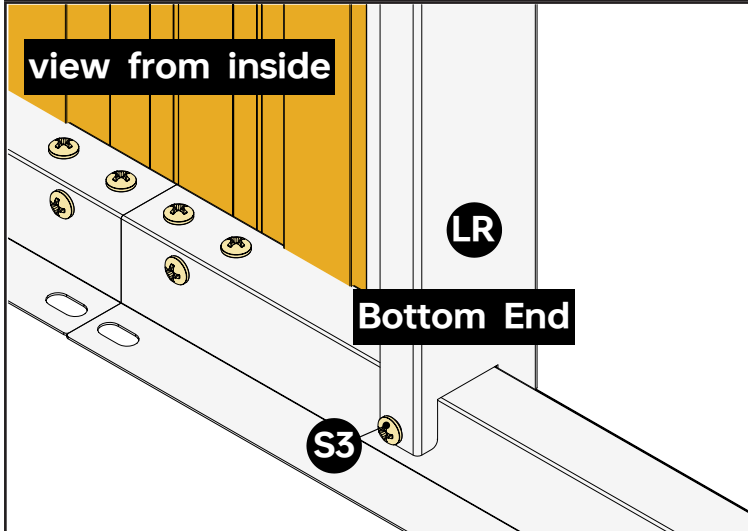
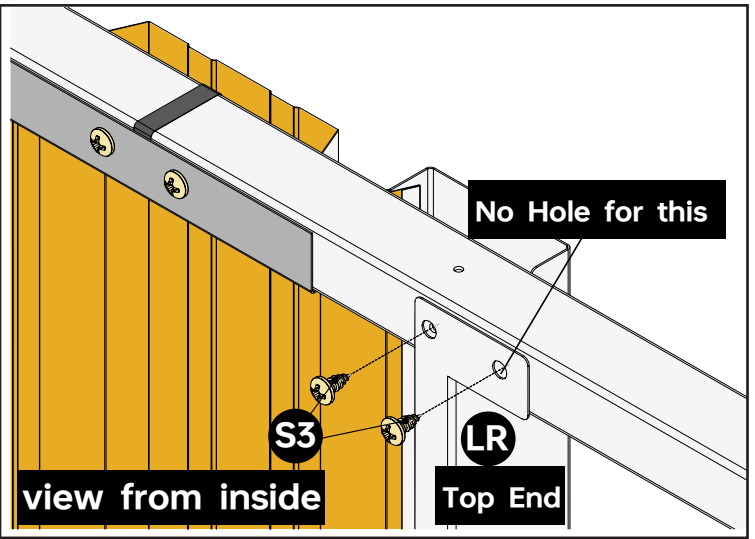
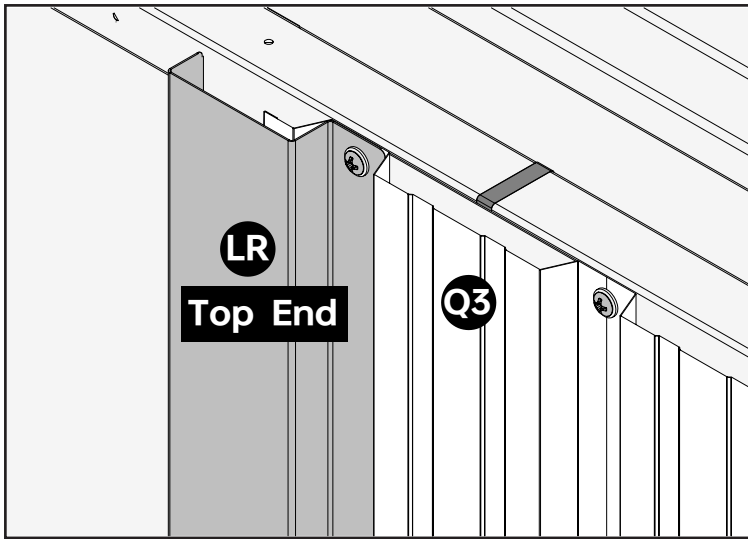

**NOTE**  
 When attaching LL and LR, you will have to go inside the shed, and find the three screw holes on LL and LR.  
 Note that, you will not find a screw hole on B2+B7+B3 frame that is corresponding to the screw hole on the bent part of LL and LR. This is a deliberate choice made by the designer. B frames are made of aluminum so you can still drive the screws into the them fairly easily.

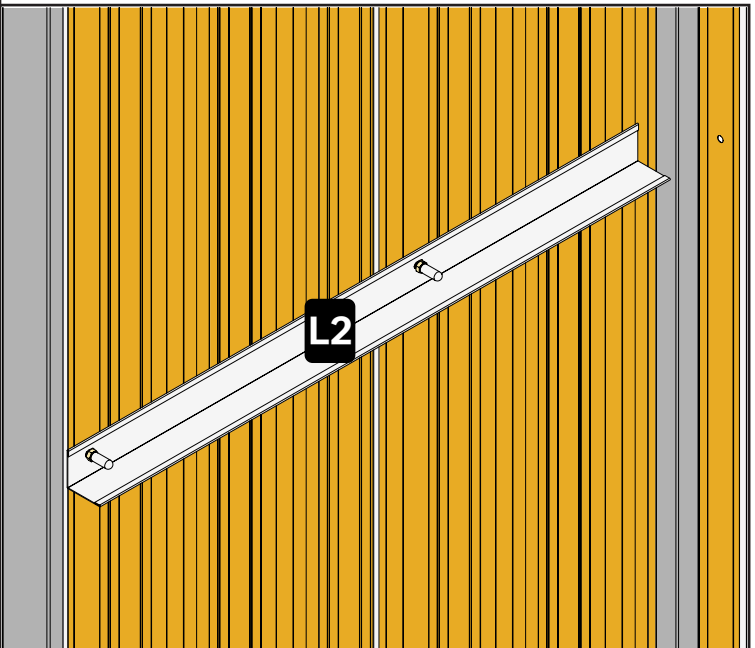
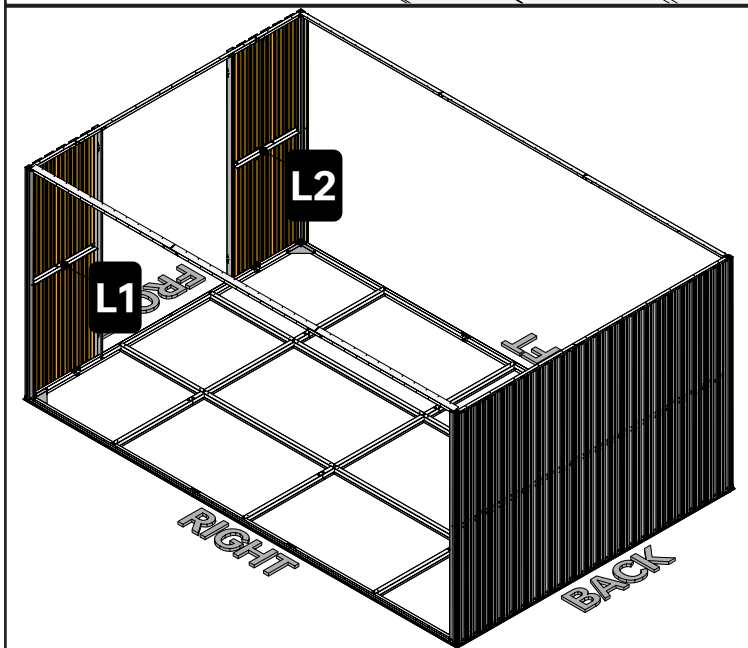

Note that for L1 and L2 placed in the front of the shed, they are used to connect LR/LL to the rest of the wall panels.

Part	Qty
L3	1
L4	1
Q1	5
Q3	3
S1	7
S2	7
S3	54
S4	61
S5	7

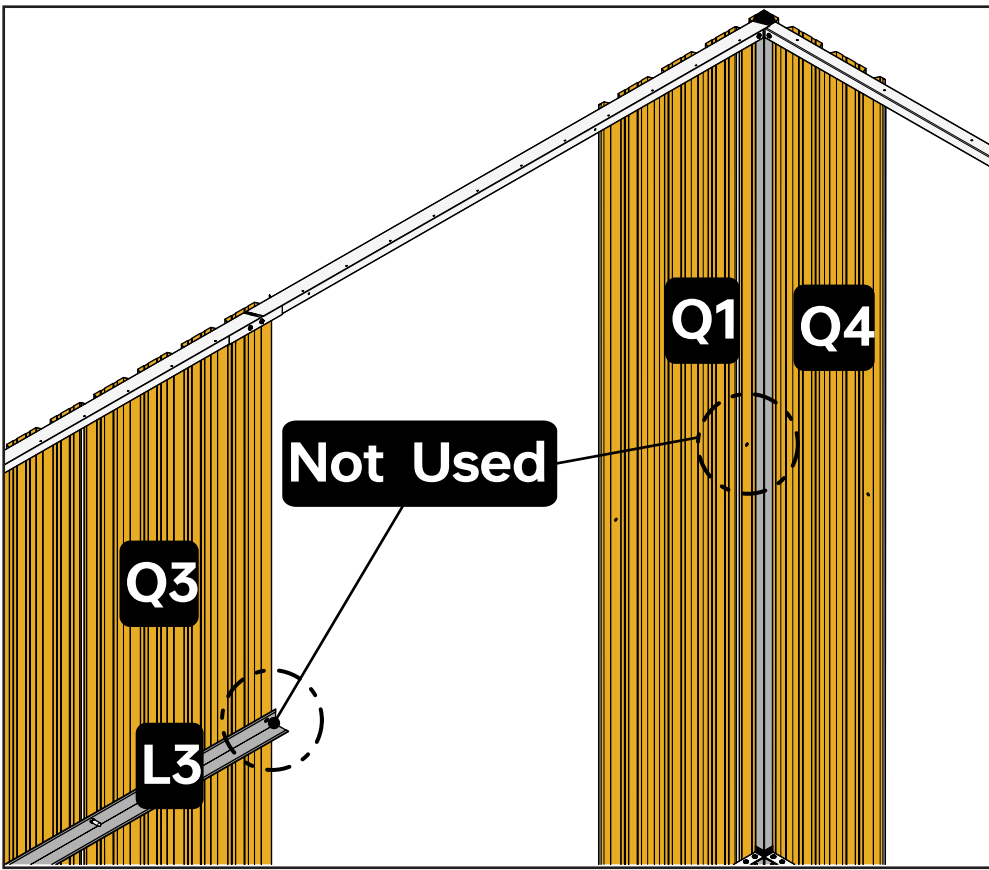
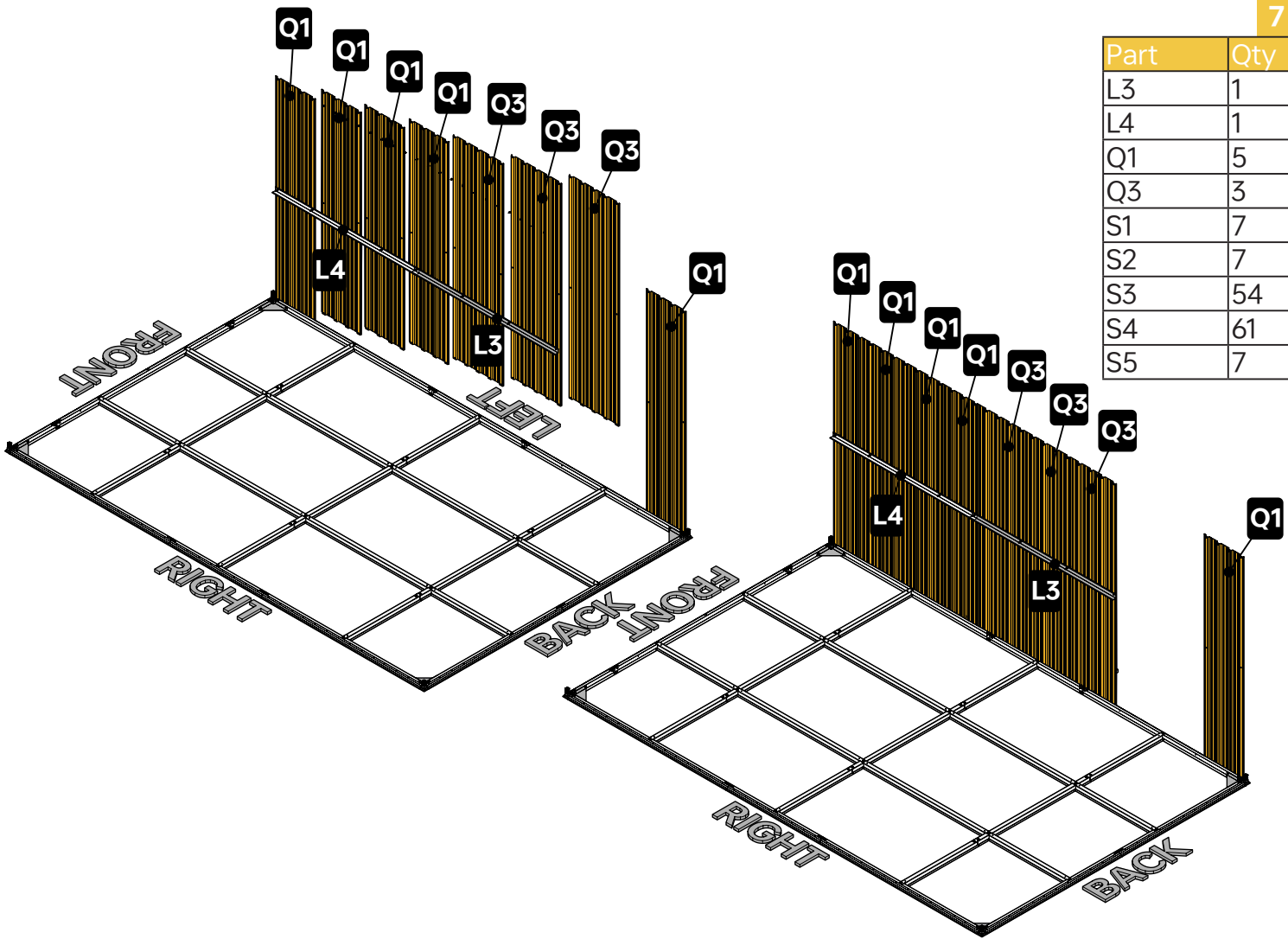

**NOTE**

Some panels and parts are hidden in this step to improve visibility.

There are two screw holes for S1+S2+S4+S5 that should be left unused in this step.

- 1) the screw hole that connects Q1 to Q4.
- 2) the screw hole that is at the right end of L3.

Screw holes for S3+S4 on Q1 and Q3 that are closer to the edge are not used either. This is similar to step 4 of this chapter.

Part	Qty
L3	1
L4	1
Q1	5
Q3	3
S1	7
S2	7
S3	54
S4	61
S5	7

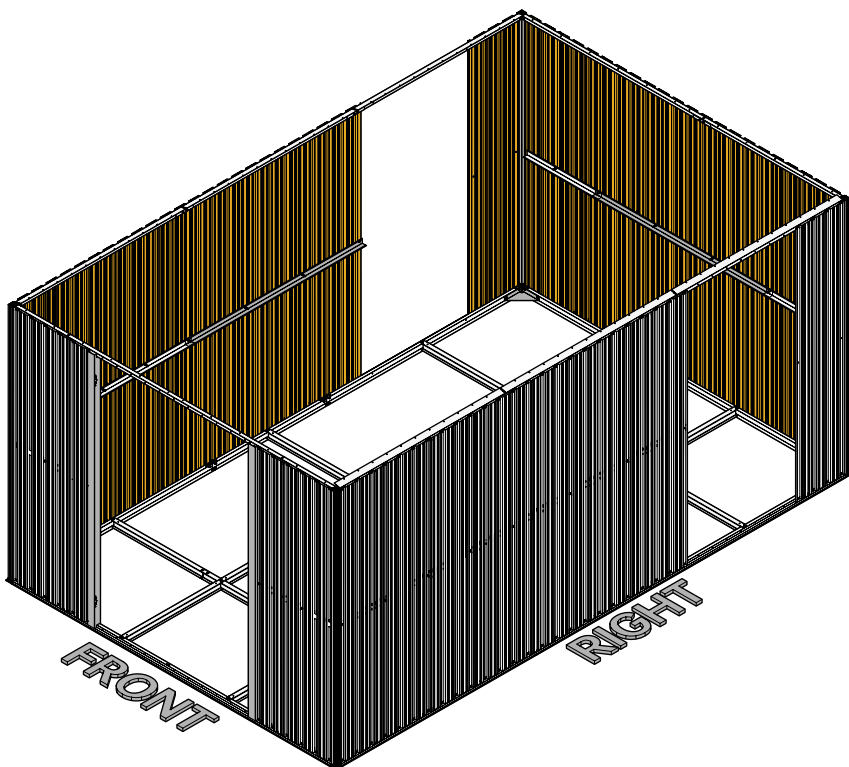
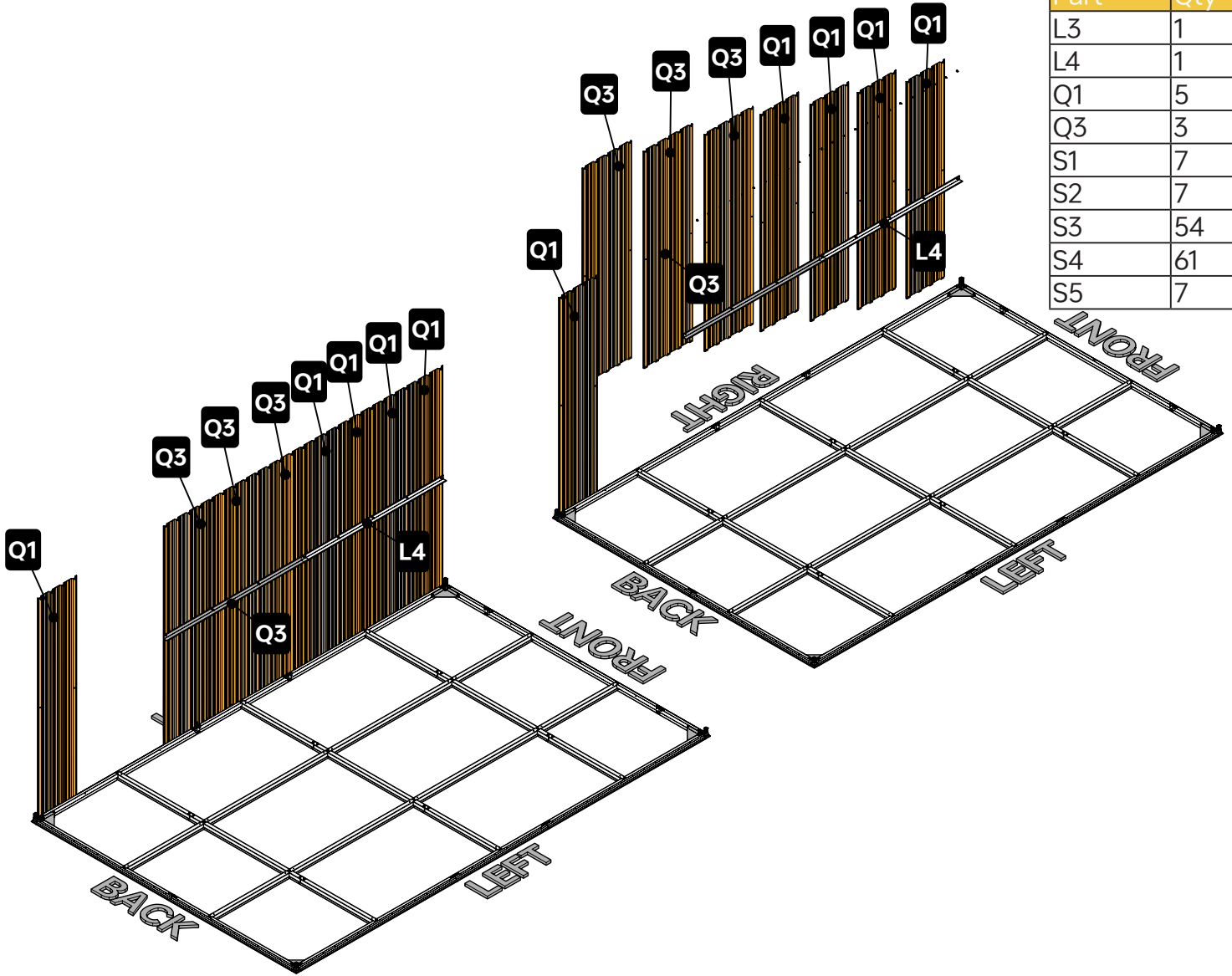

This is what the shield looks like after this step is done.

9 OPTION 1 SIDE DOOR ON THE RIGHT SIDE OF THE SHED

Part	Qty
L5	1
L6	1
Q3	2
S1	4
S2	4
S3	18
S4	22
S5	4

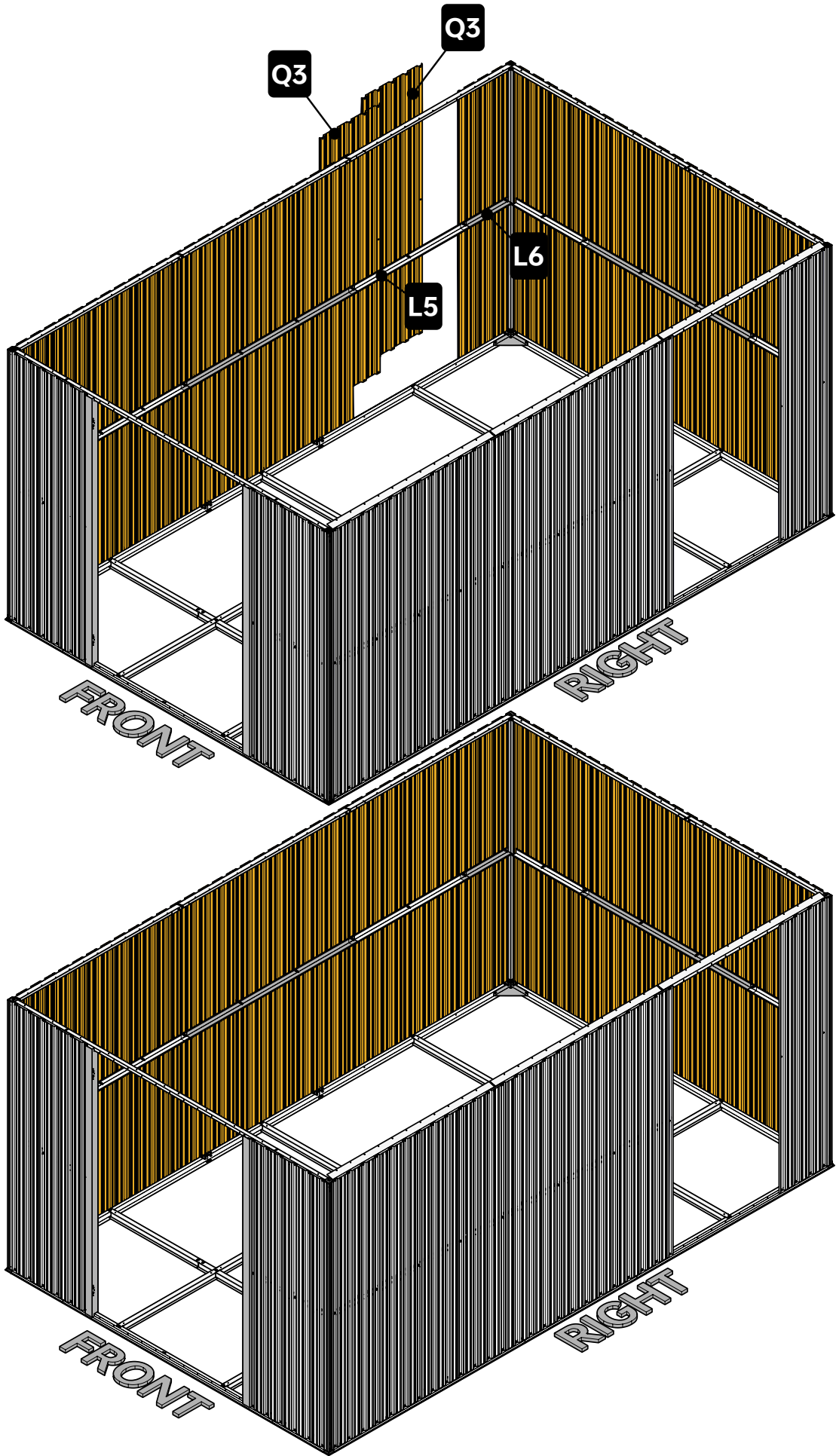

**NOTE**

After this step is done, the left side of the shed is completely sealed off.

Part	Qty
CM	1
L6	1
LK1	1
LL8	1
LR8	1
S1	3
S2	3
S3	21
S4	16
S5	3

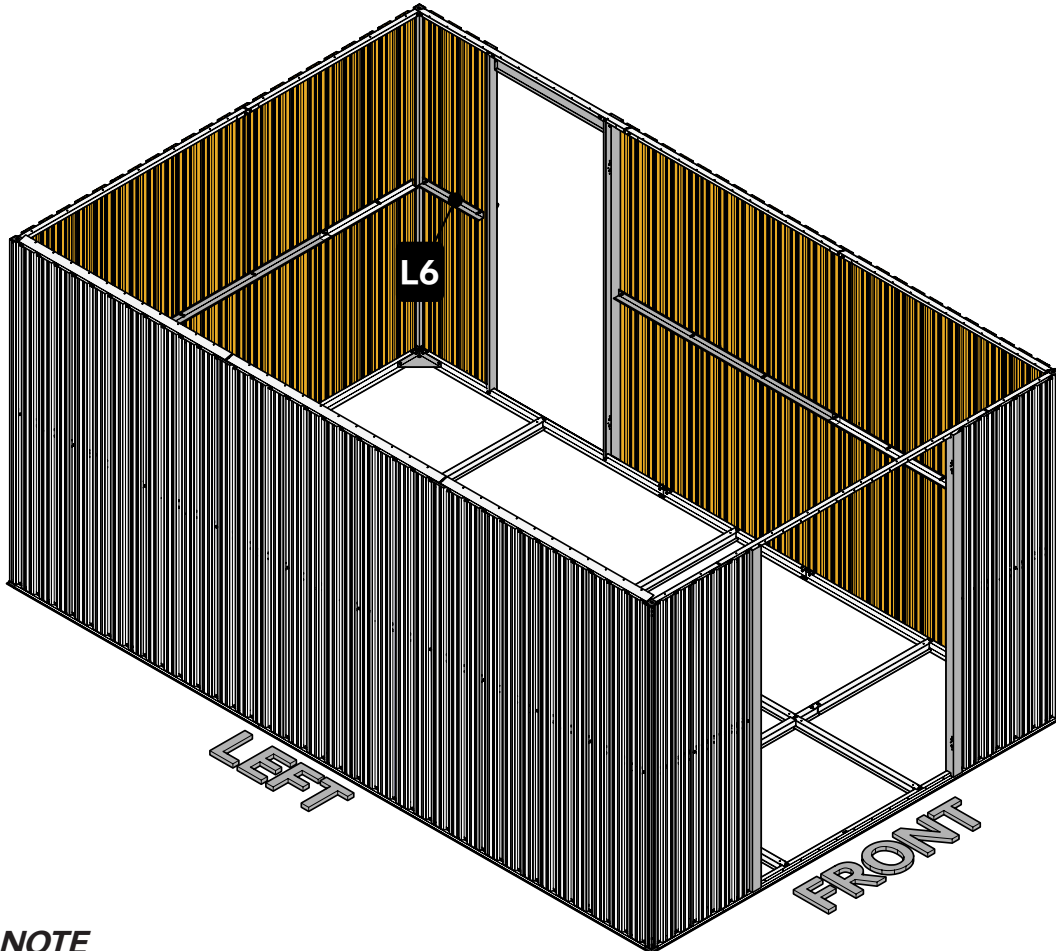
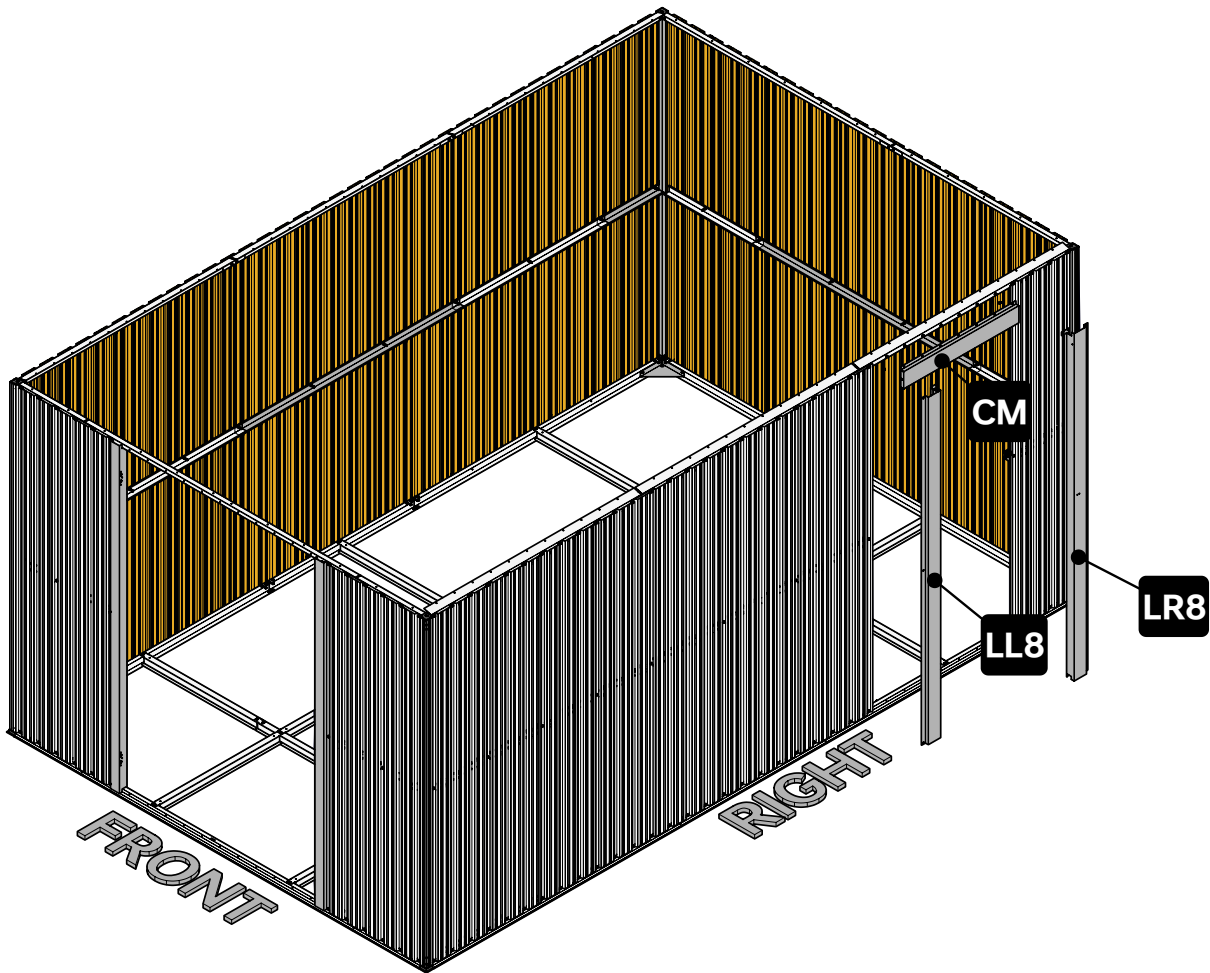
**NOTE**

Attaching LL8 and LR8 is the same as attaching LL and LR. You will need to bend the top end of LL8 and LR8

Continued on next page for this step.

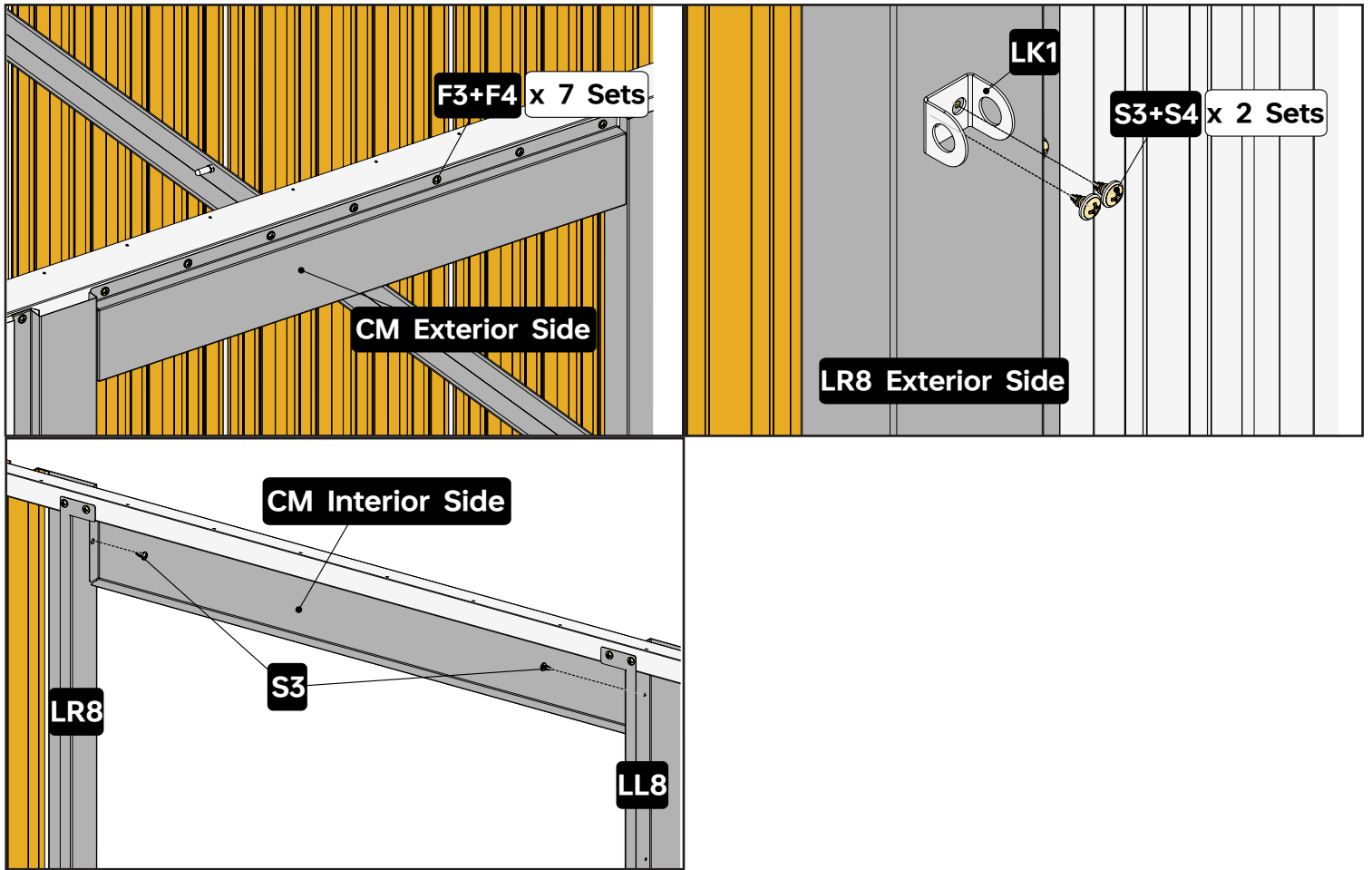

**NOTE**

Part CM is connected to LL8 and LR8 using two S3.  
 CM is connected to B frames using seven sets of S3+S4

OPTION 2 SIDE DOOR ON THE LEFT SIDE OF THE SHED

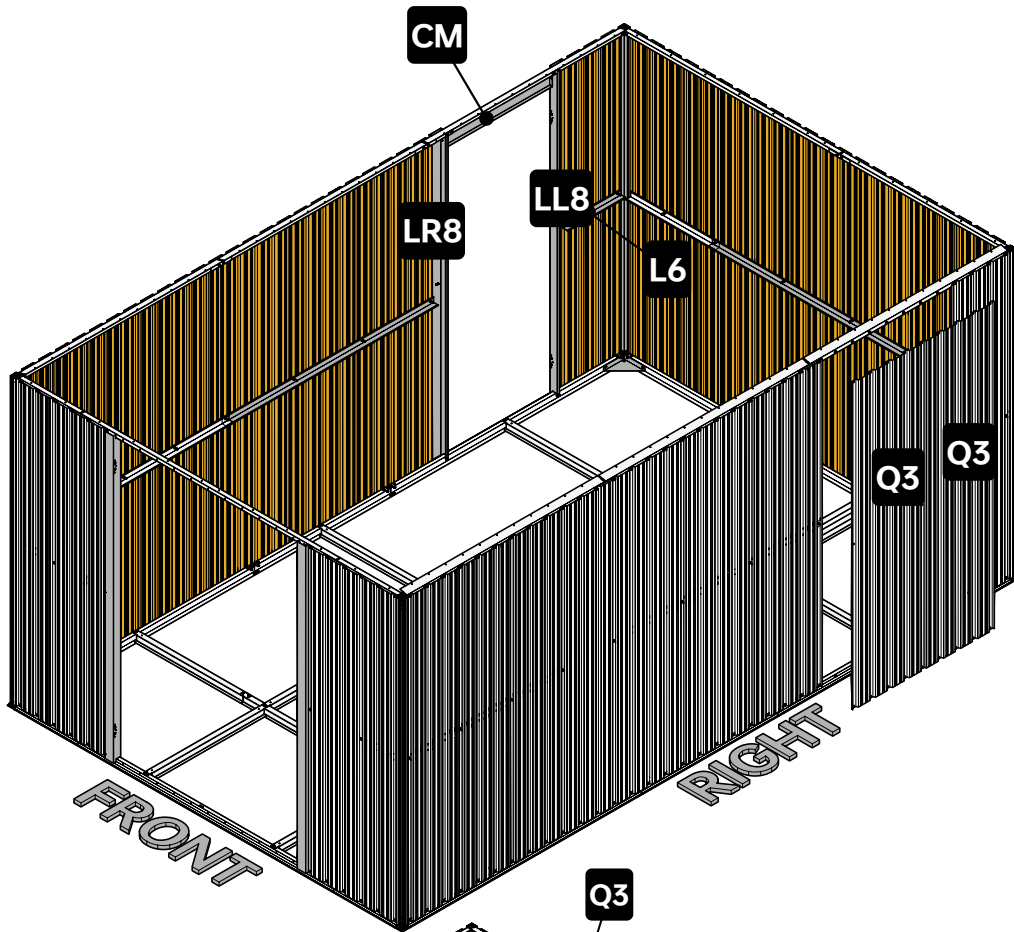

Part	Qty
CM	1
L5	1
L6	2
LK1	1
LL8	1
LR8	1
Q3	2
S1	7
S2	7
S3	39
S4	38
S5	7

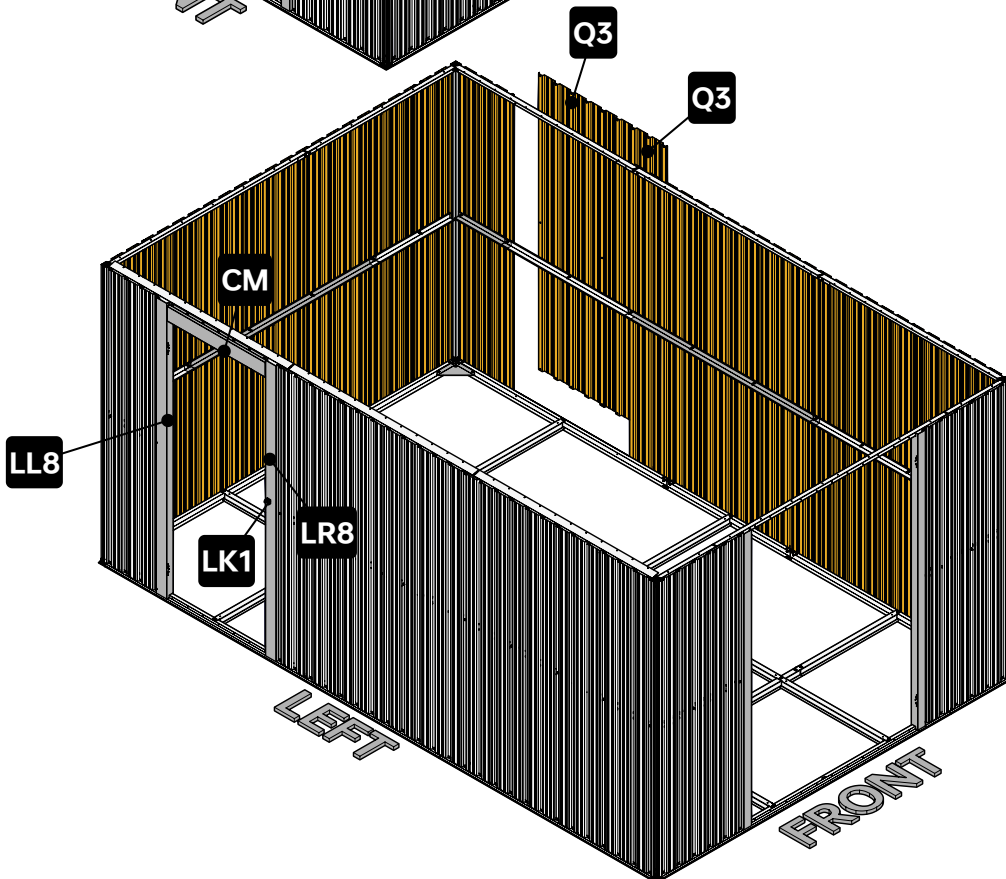

**NOTE**  
 This step is the similar to last two steps. Only the direction is different. Two sets of Q3 are installed on the right side, and LL8+LR8+CM is placed on the left.

This marks the end of chapter 5. Starting from next chapter, we will only show the layout where the side door is placed on the right of the shed.

# 05 Roof

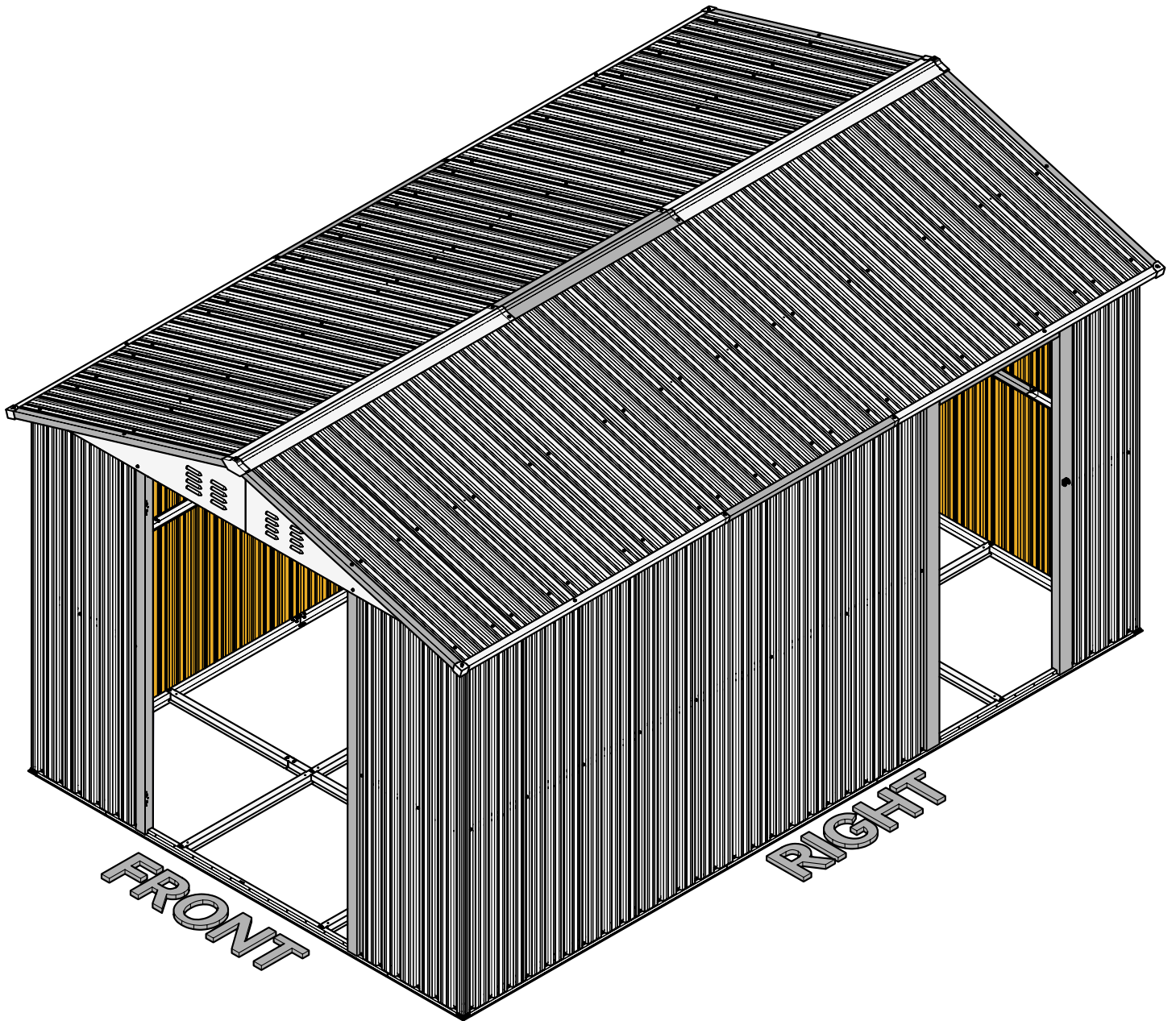

x 2

Part	Qty
SL	2
SR	2
J1	4
J2	4
S1	12
S2	12
S4	8

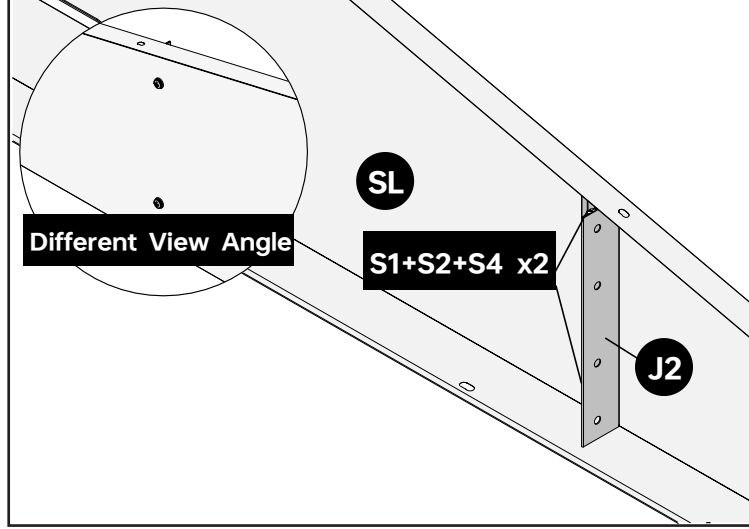
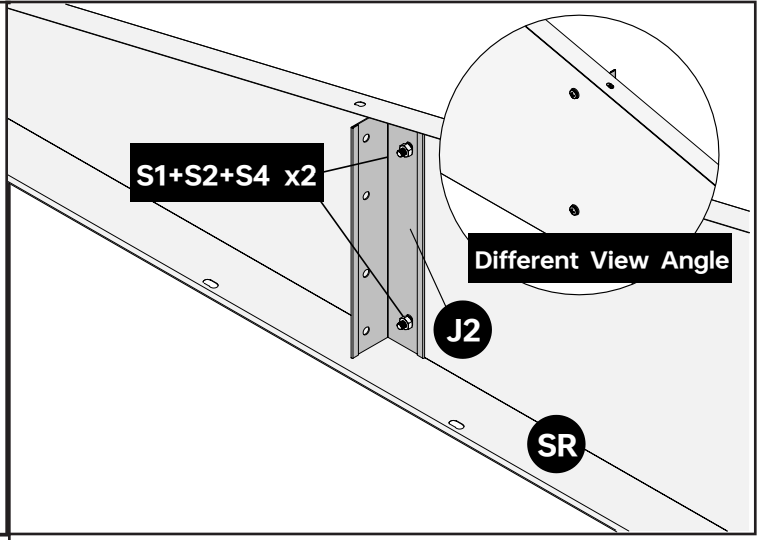
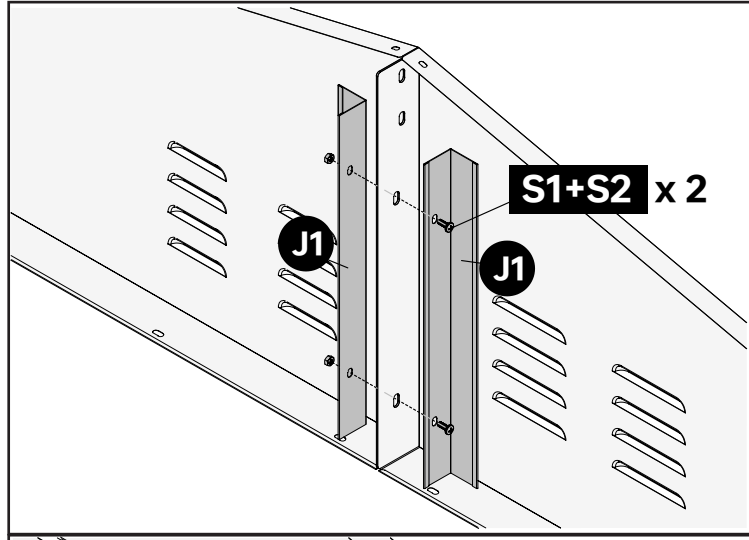
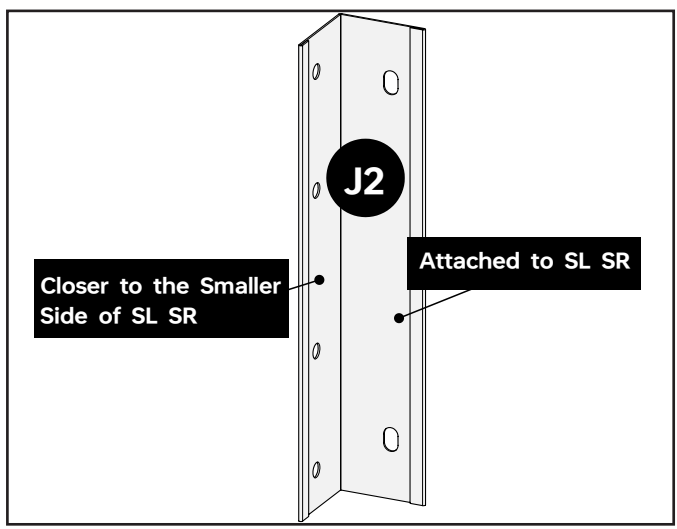
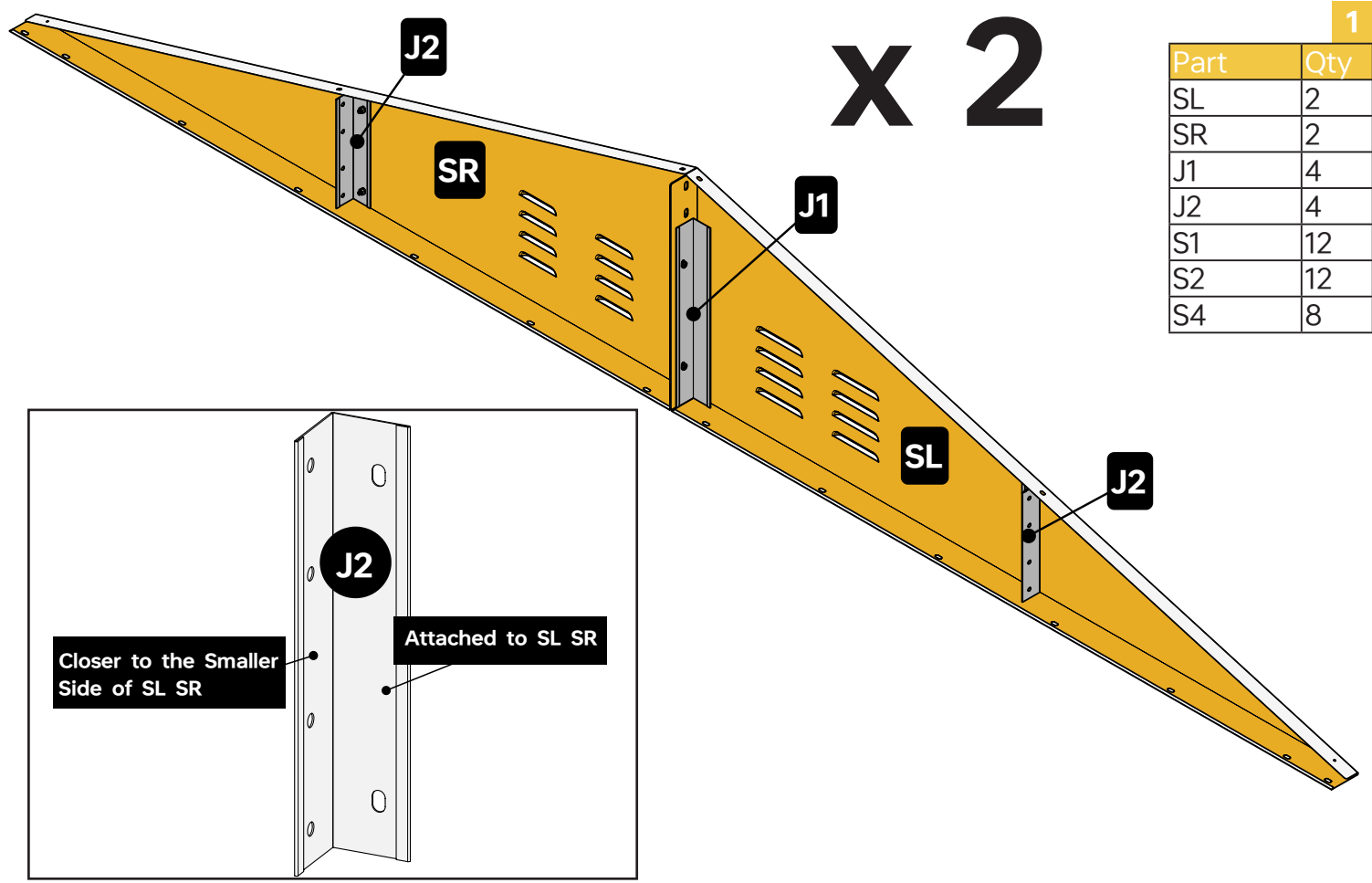

**NOTE ABOUT BRACKET J2**  
 J2 has two different sides. When placing J2, make sure that the side with four smaller screw holes is placed closer to the smaller end of SR/SL, as shown above.

When attaching J1 to SL/SR, make sure that you are using the lower two screw holes on SL/SR and leave the top two unused.

Repeat this step so you have two sets of SL+SR.

2

Part	Qty
H1	2
H2	2
H3	2
HL	4
S7	32
S8	32

x 2

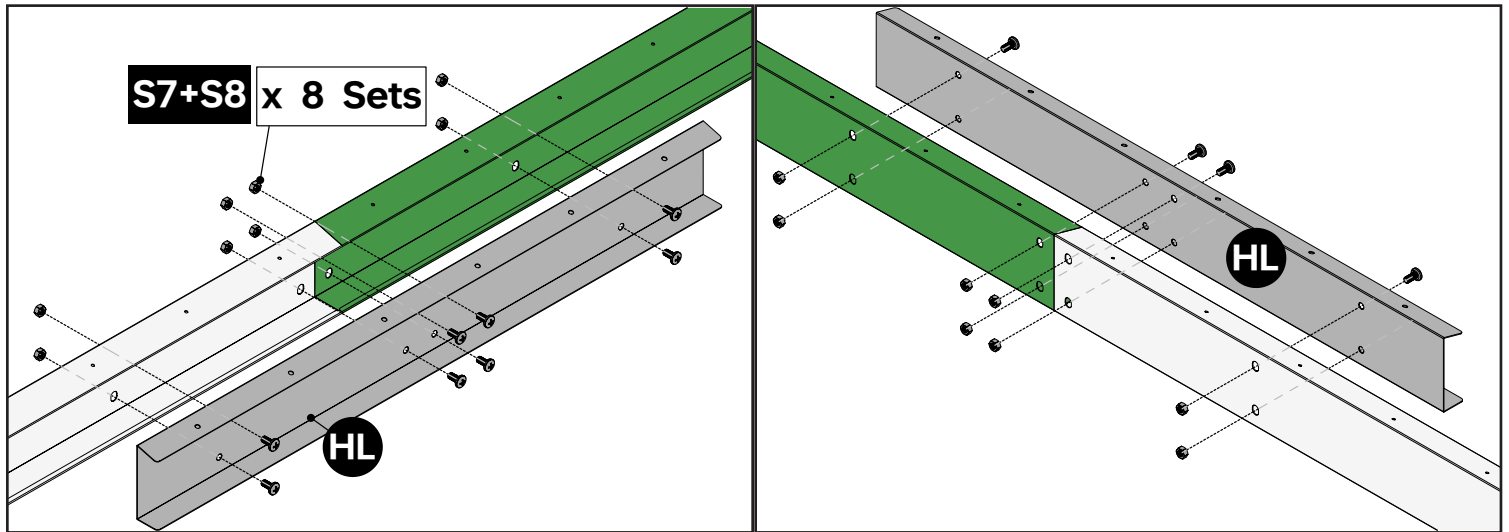
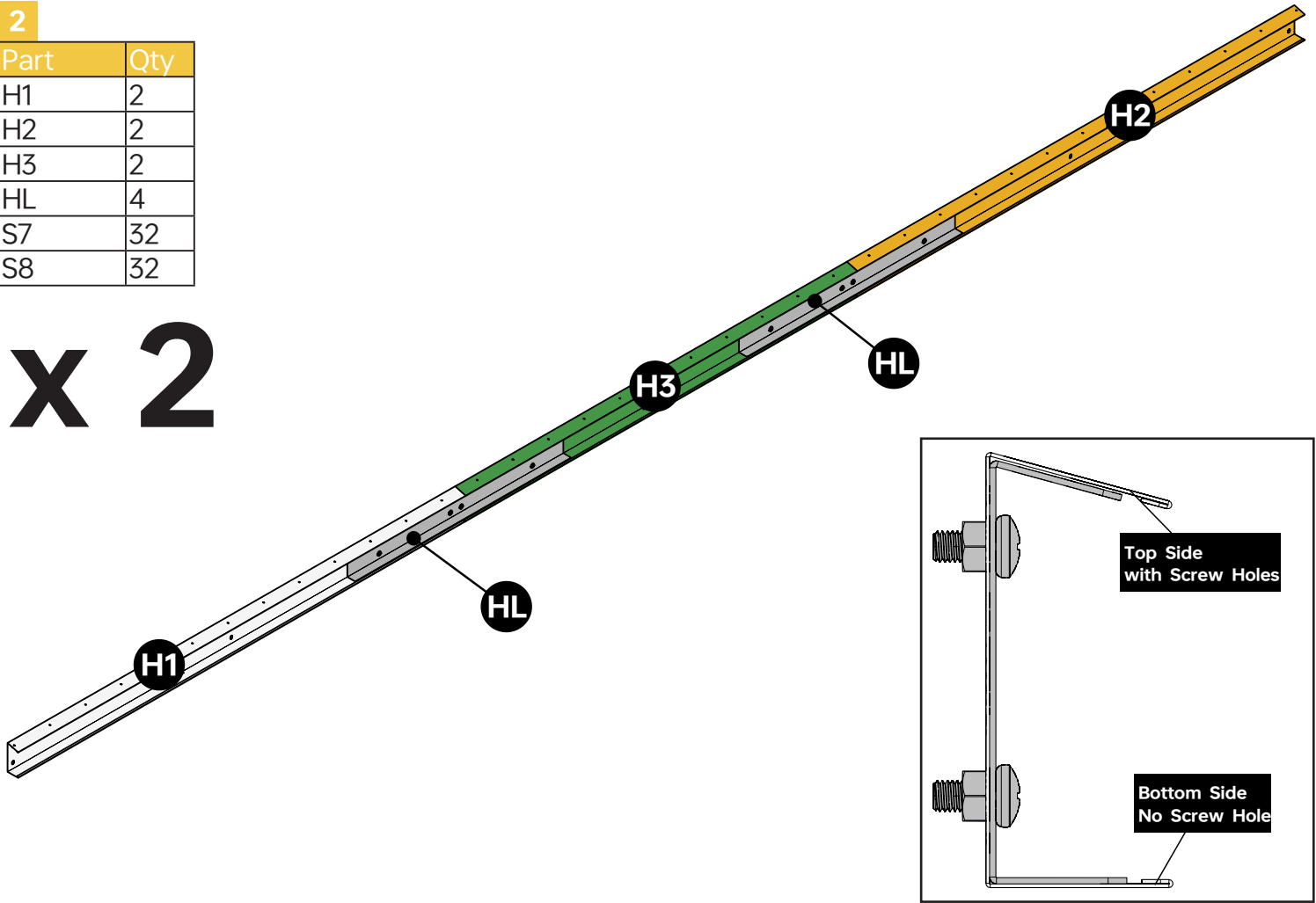

**NOTE**

H1H2H3 and HL have two different sides, the slanted side with screw holes are the top side, and the other side is the bottom side. The layout above is the only acceptable layout of H1+H2+H3. Use S7+S8 to connect H1H2H3 and HL together. Repeat this step so you have **TWO** sets of H1+H2+H3.

3

Part	Qty
H1	2
H2	2
H3	2
HL	4
S7	16
S8	16

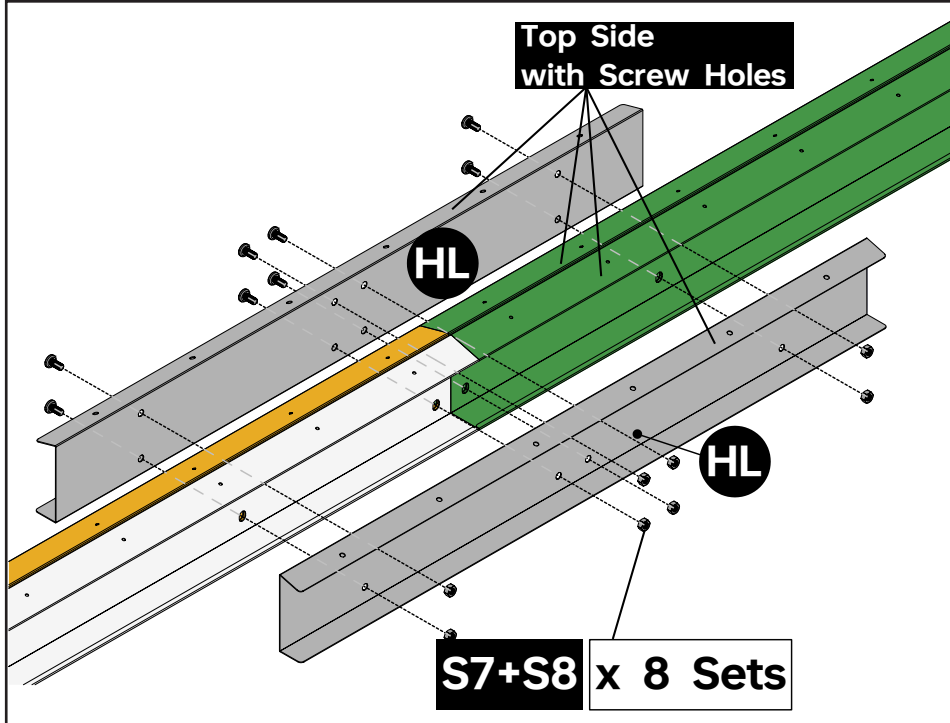
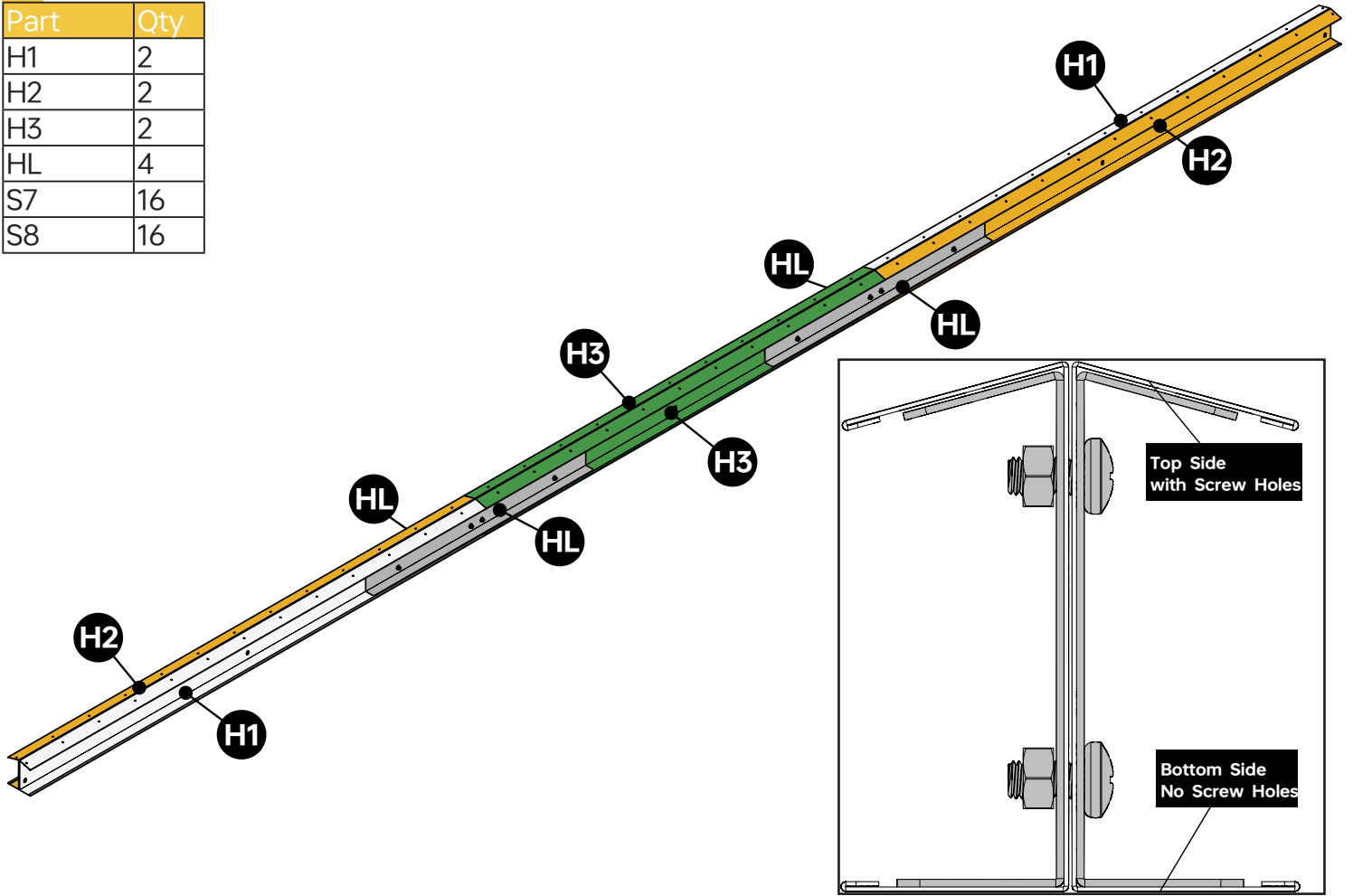

**NOTE**

Do not confuse this step with the last step. The H1H2H3 used here are the ones that are not used in last step. You do not need to dismantle the completed H1+H2+H3 structure.

Part	Qty
S3	28

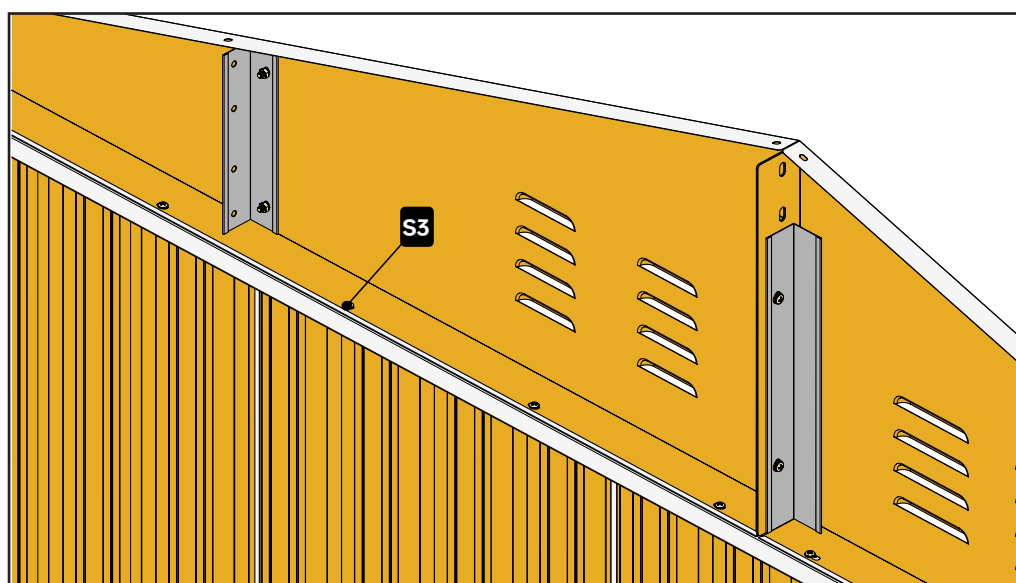
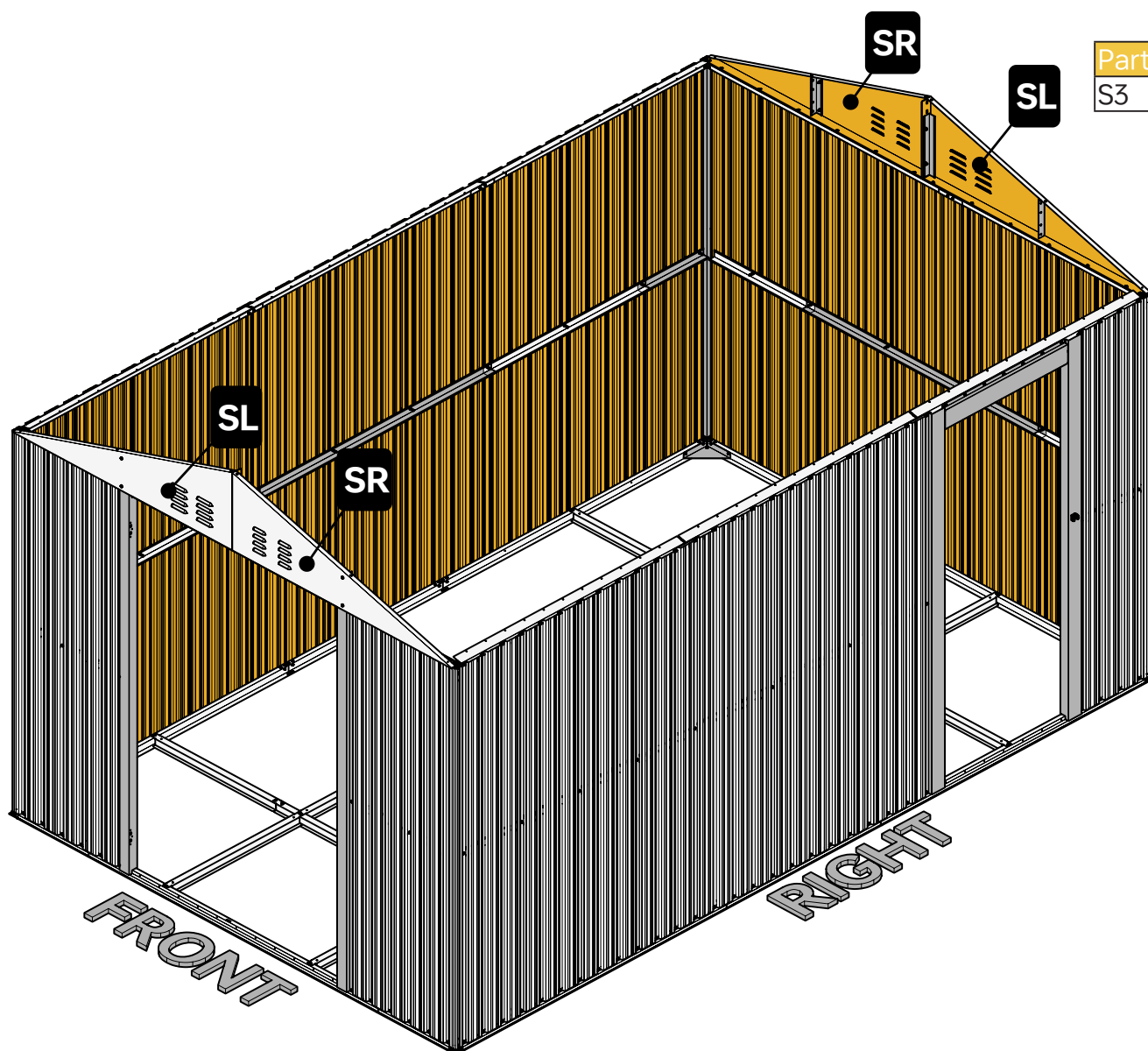

**NOTE**

Use 28 x S3 to secure one set of SL+SR to the frames. No S4 is needed.

Part	Qty
S7	12
S8	12

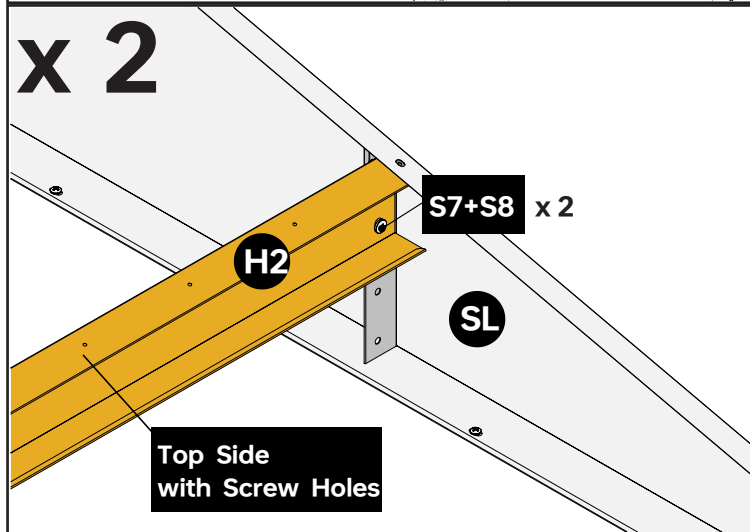
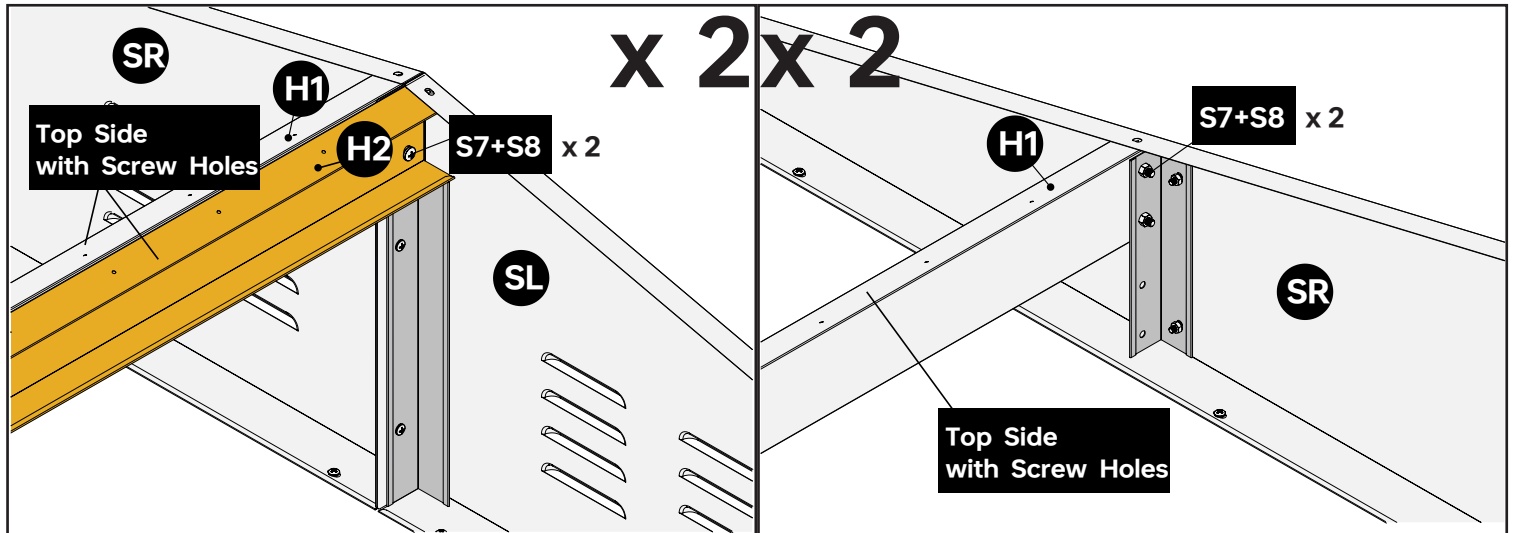
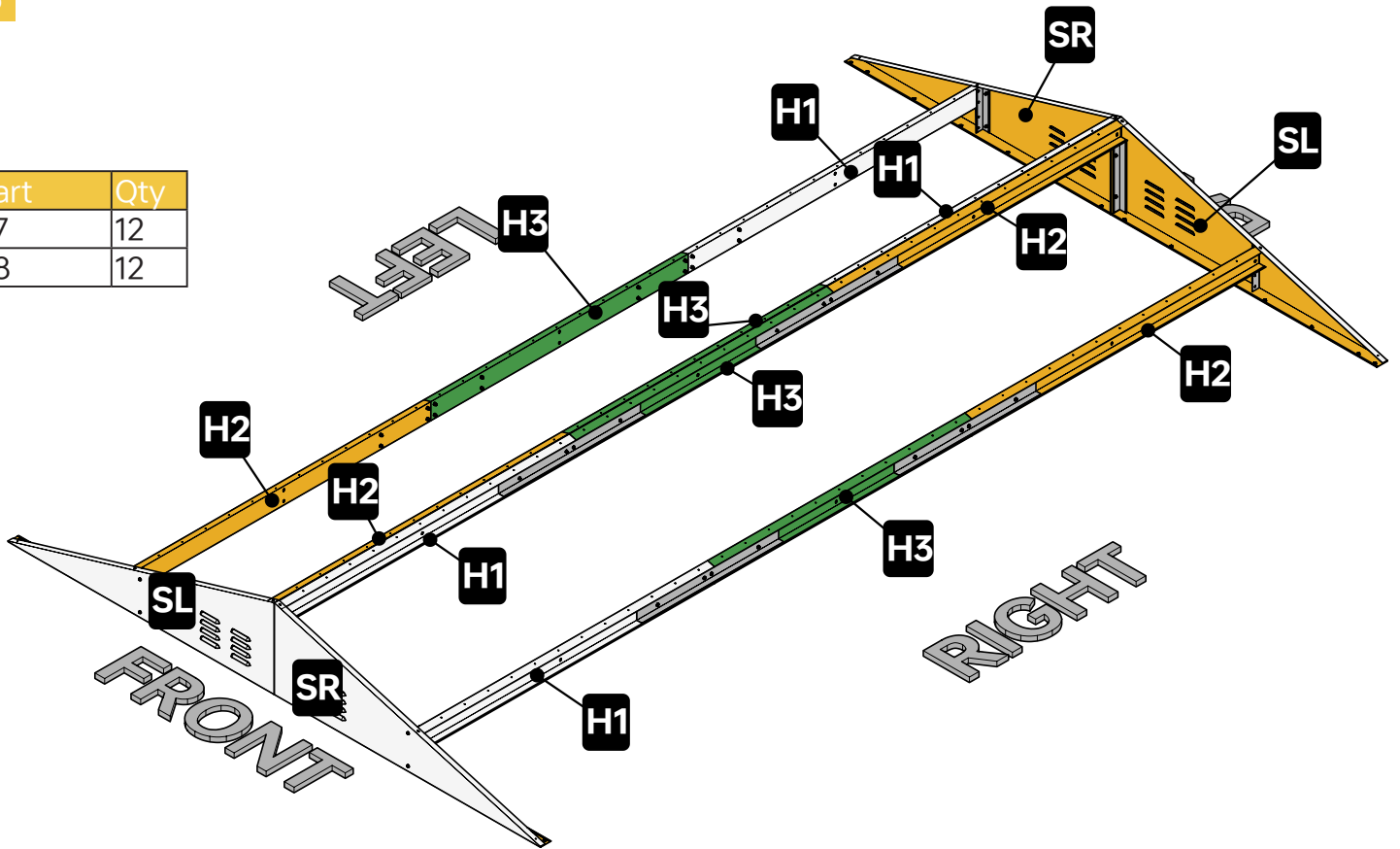

**NOTE**

- Some rules to make this step smoother:
- 1) always attach H1 to SR and H2 to SL.
  - 2) make sure the screw holes on H1+H2+H3 are on top.
  - 3) use S7+S8 to secure H1+H2+H3 to J1 and J2.
  - 4) use the top two screw holes on J2.

**VISIBILITY**

From this step, the wall and base part of the shed will not be shown. This is to increase the visibility of the roof panels.

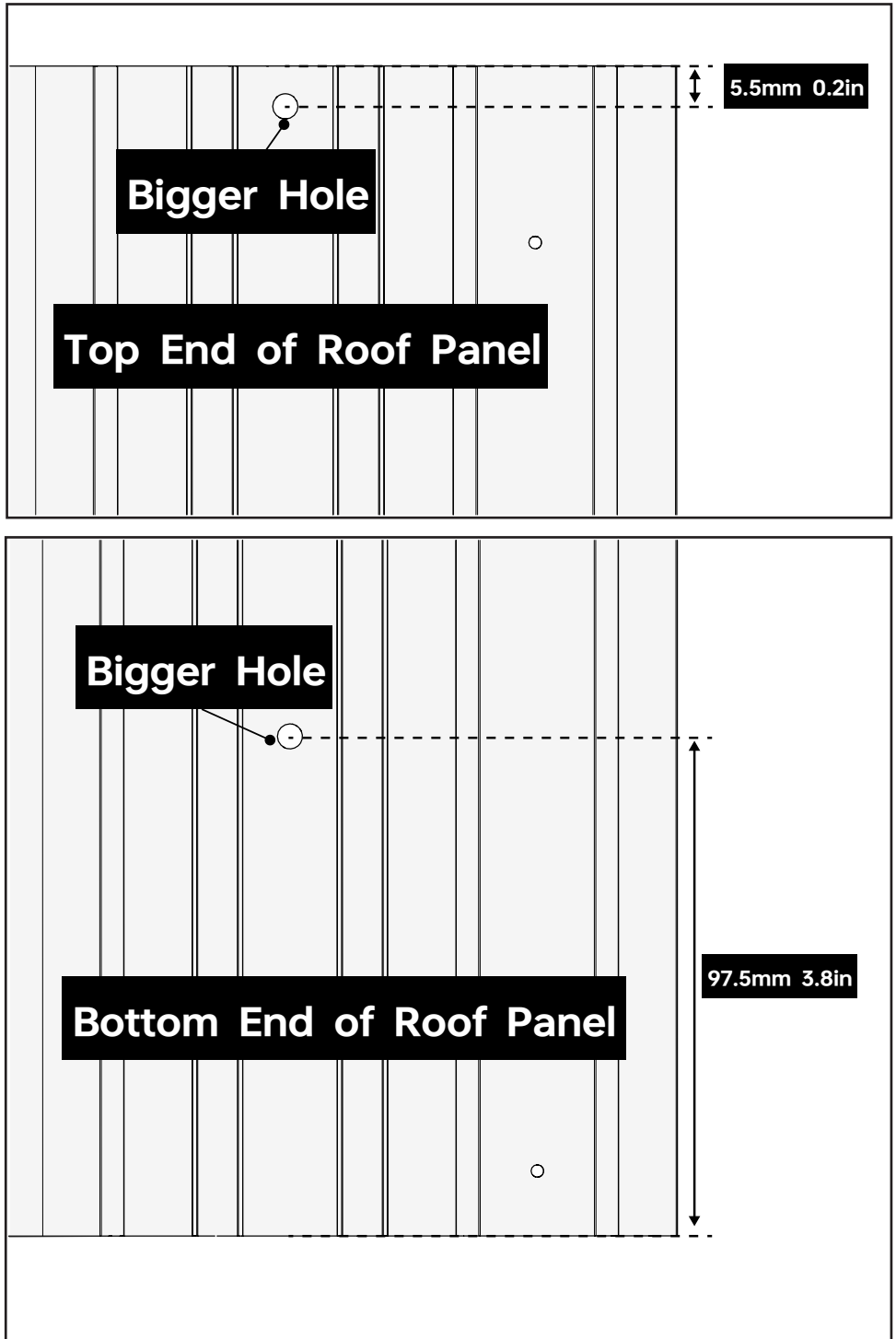
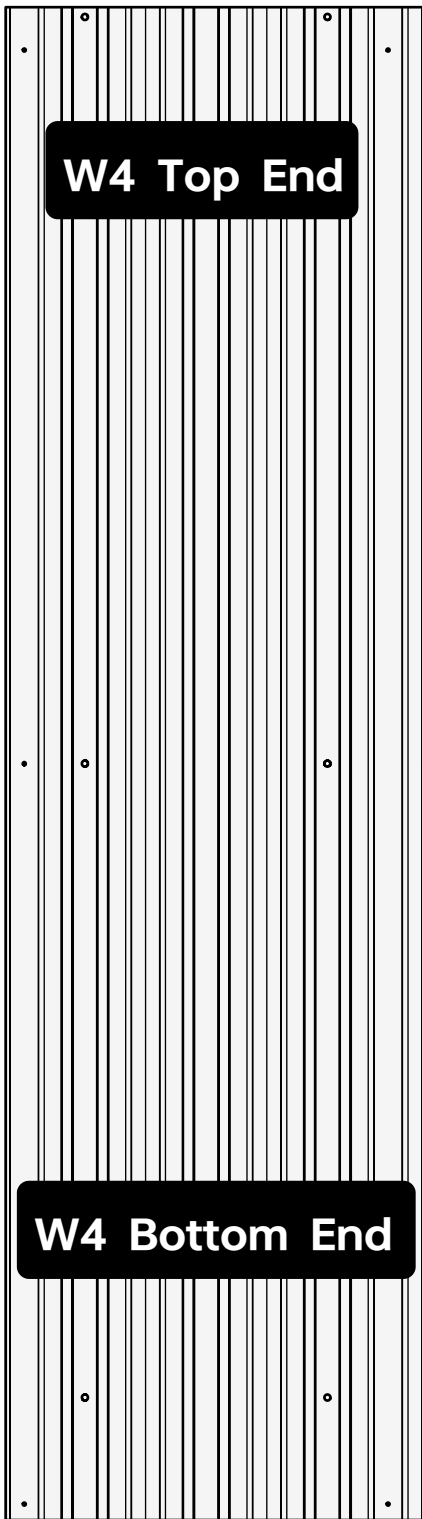

**NOTE**

**IDENTIFYING THE TOP AND BOTTOM ENDS OF ROOF PANELS W1, W2, AND W4:**

Roof panels W1, W2, and W4 each have a distinct top and bottom end. To determine the orientation: Locate the end of the panel with the bigger screw holes closer to the edge. This is the bottom end. The opposite end, with the bigger screw holes further from the edge, is the top end.

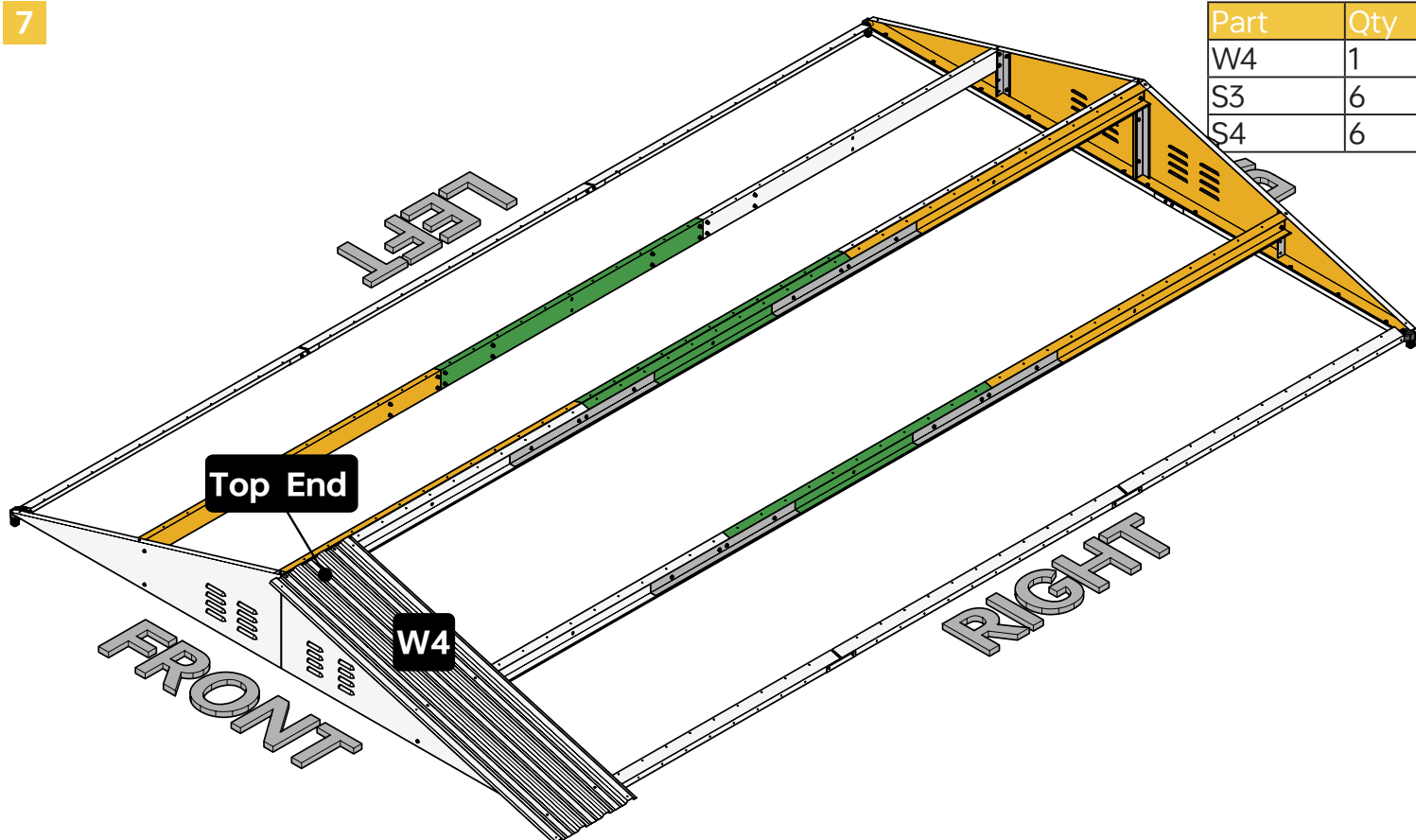

Part	Qty
W4	1
S3	6
S4	6

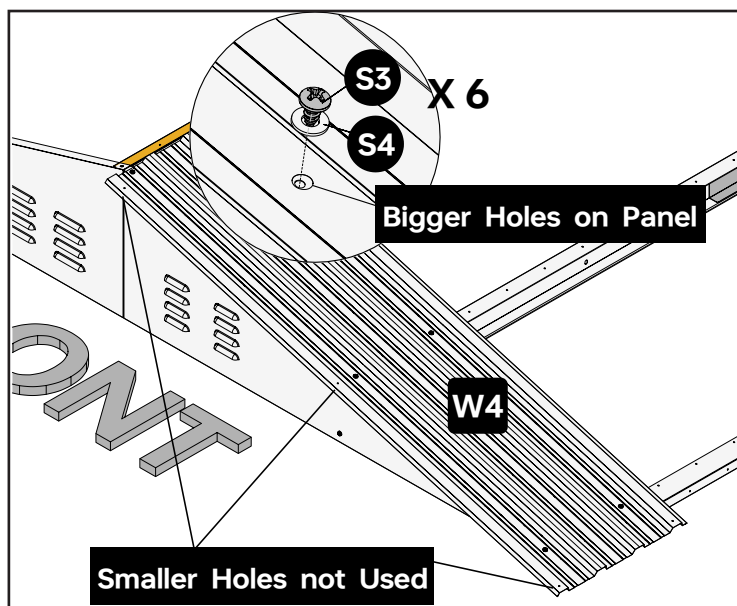

#### NOTE

When attaching W4 to the rest of the shed, use the six bigger screw holes instead of the smaller screw holes.

Three sets of S3+S4 screw will connect W4 to SR. SR have three screw holes corresponding to the bigger screw holes on W4.

After this step, the quantity of S3+S4 screws to be used on roof panels will not be shown in the illustrations. It will still be shown in the part/qty table.

This is to avoid cluttering the manual with unnecessary drawings.

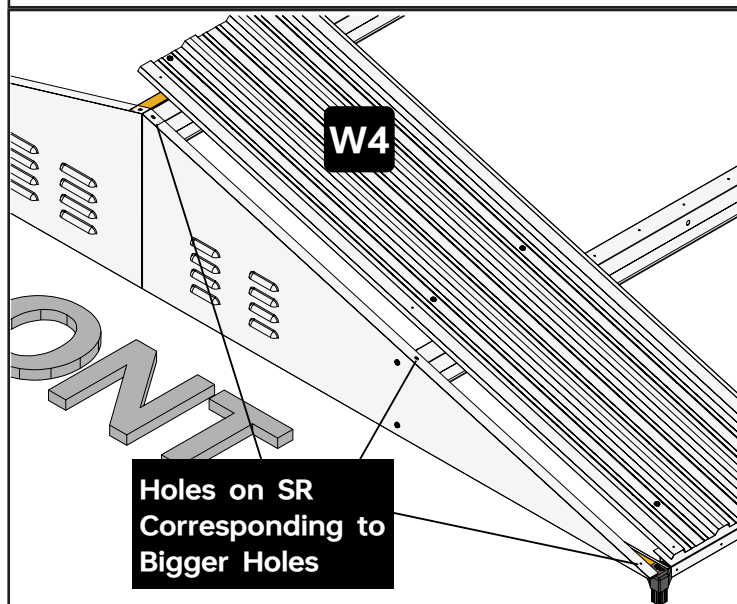

Part	Qty
S3	8
S4	8
W1	1
Y1	1
Y4	1

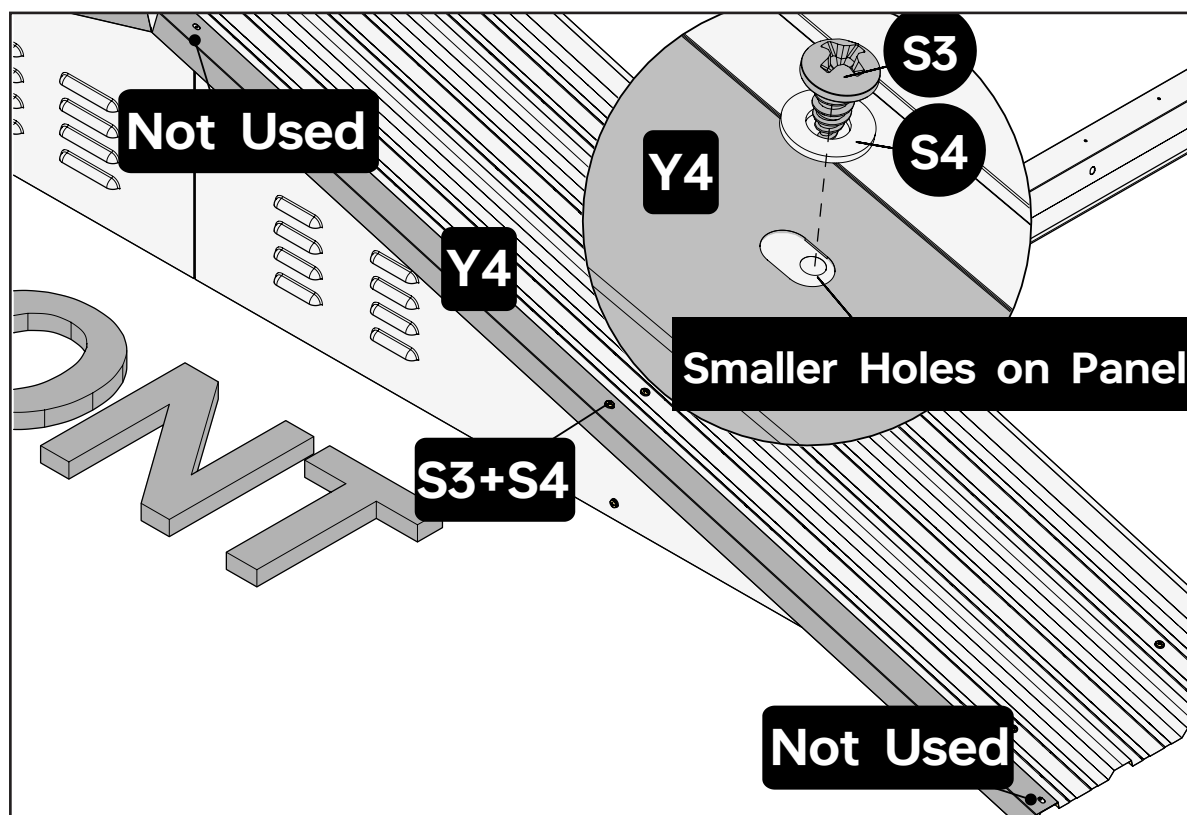
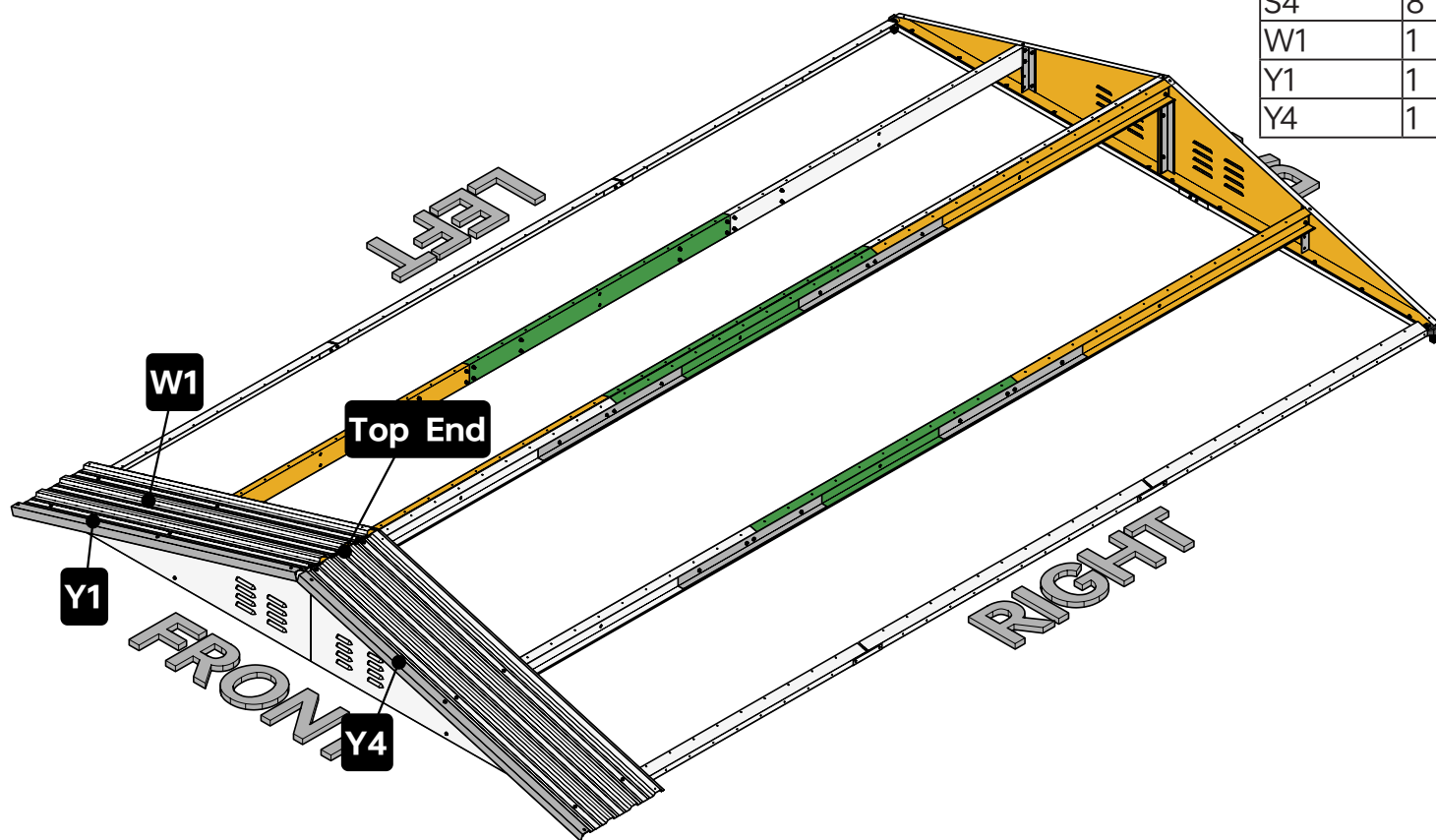

**NOTE**

Y1 and Y4 have three screw holes. For this step, only use the one in the middle. This middle screw hole corresponds to the smaller hole on wall panels.

Part	Qty
G2	1
S3	38
S4	38
W1	2
W2	4

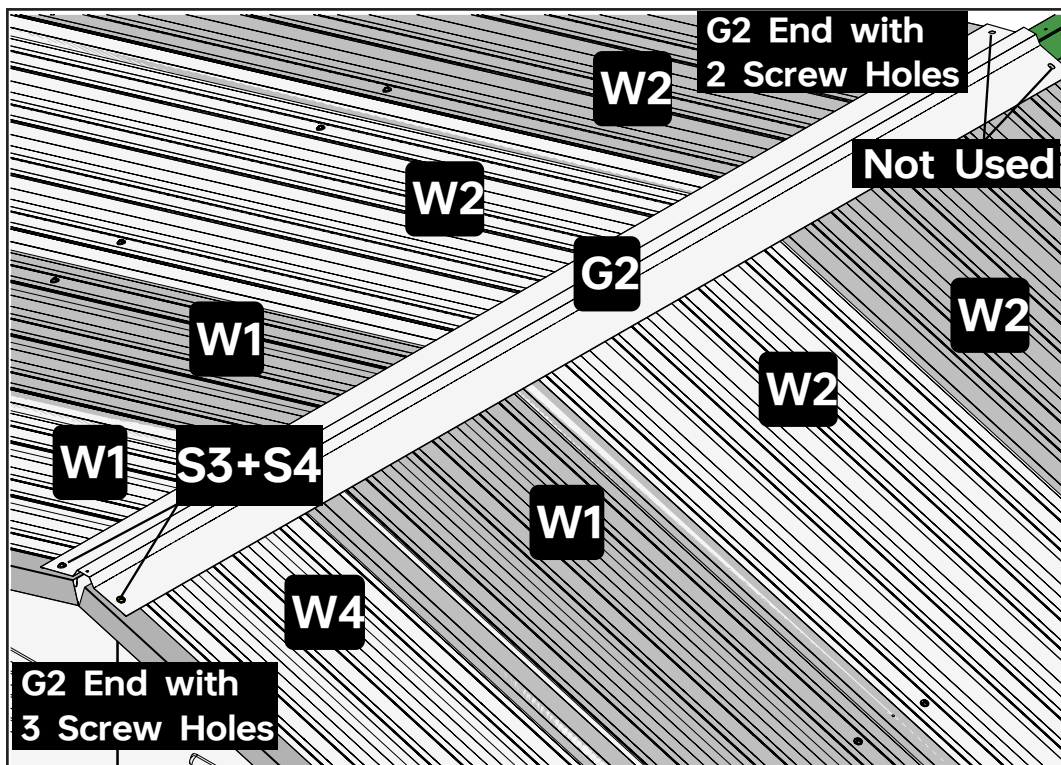
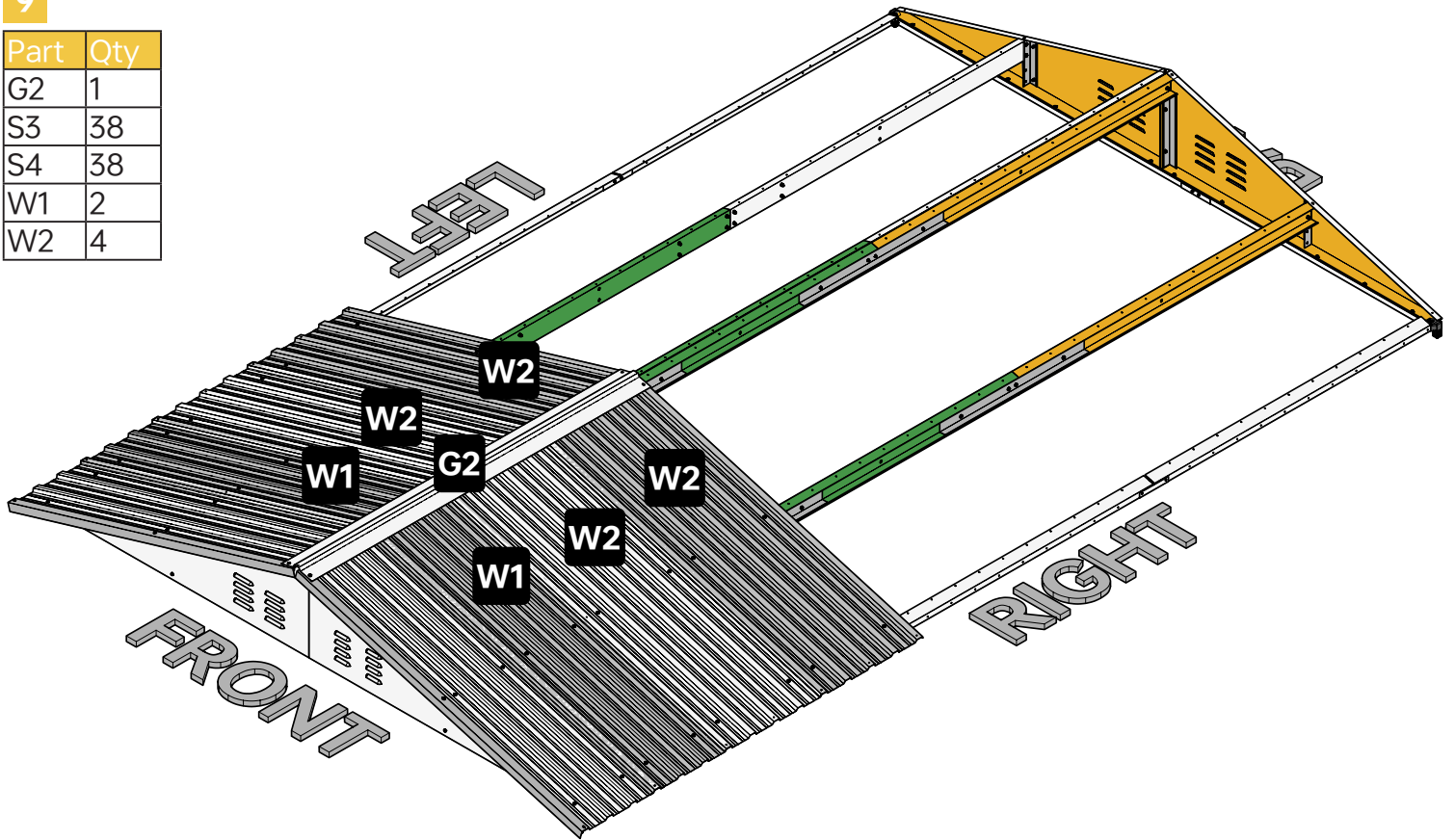

### NOTE

In the illustration above, W1/W2 panels are given different colors to improve visibility. Stacking roof panels is similar to stacking wall panels. It doesn't matter which panel is layered on top.

Part G2 has two ends, one with three screw holes and the other with two. For this step, place the end with three holes in the front. Do not use the screw holes on the end with two screw holes.

10

Part	Qty
G	1
S3	26
S4	26
W1	4

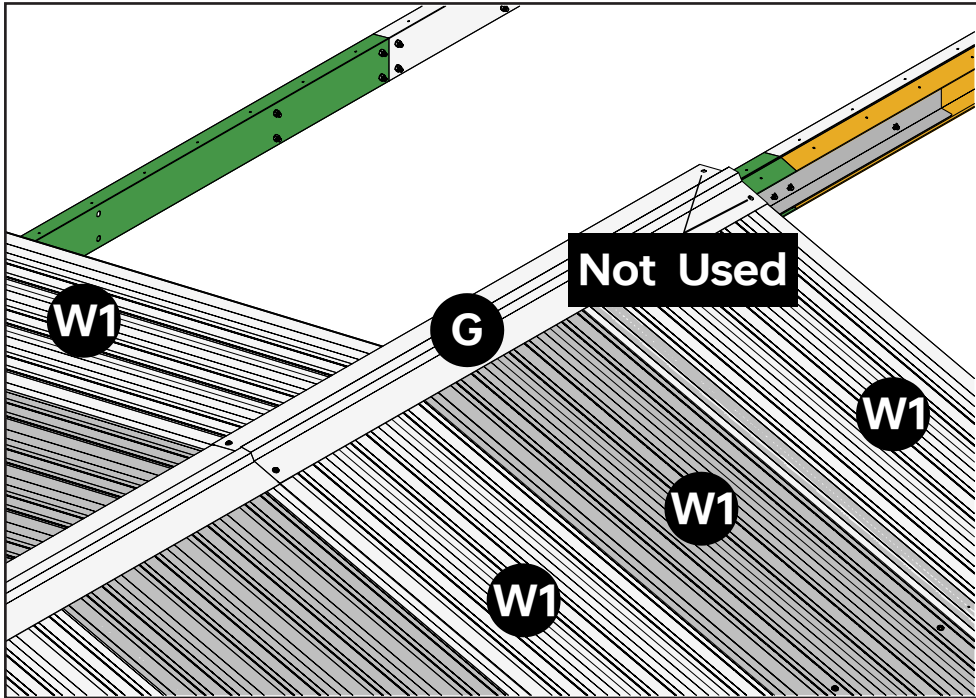
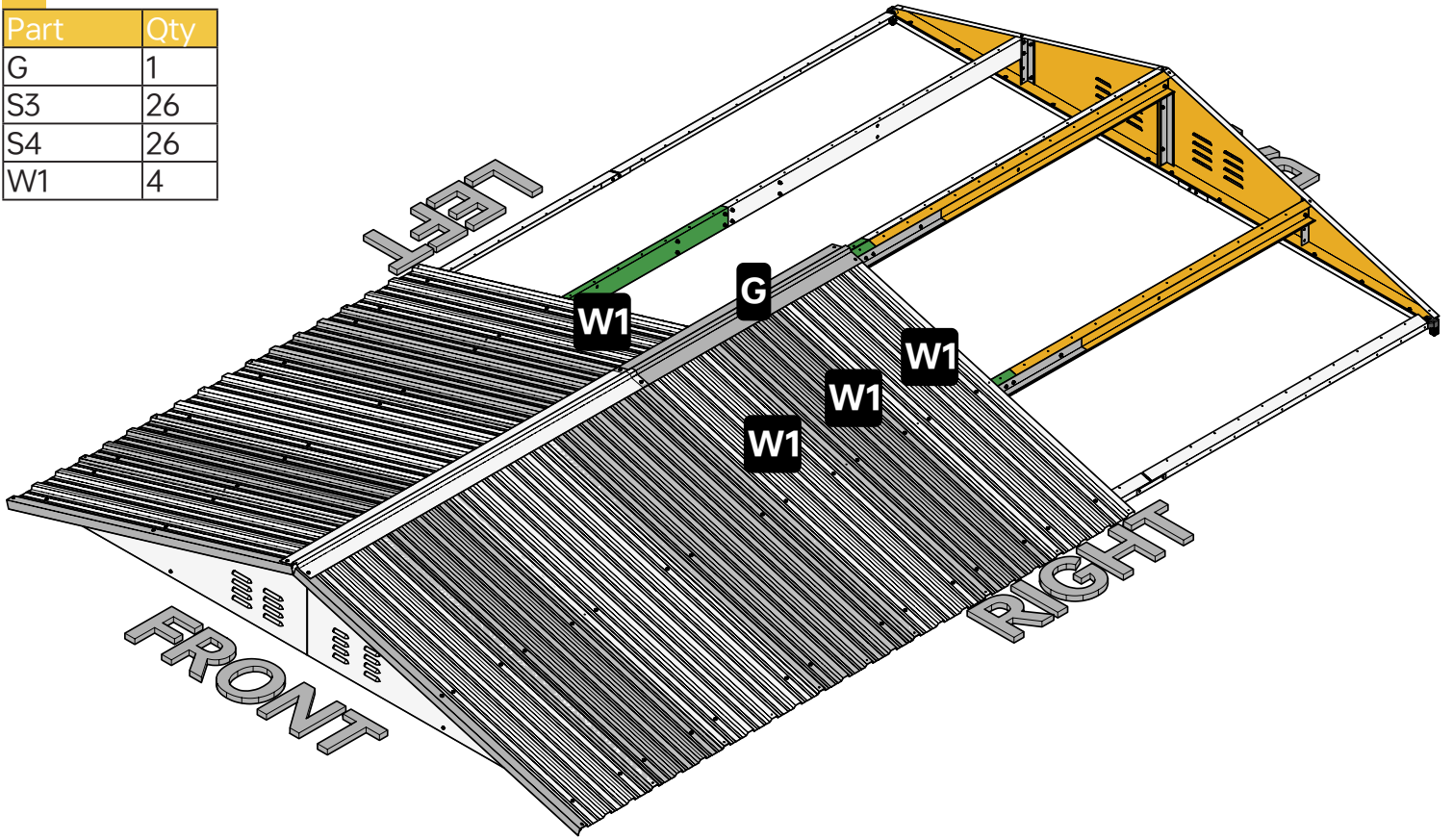

**NOTE**

The two screw holes left unused on G2 is used in this step. You might be wondering why Ridge G is used in this step. Why not use it after another two roof panels are placed. G has to be connected to the G2 in this step. If not, you will have to partially lean onto the half finished roof to get the two ridges connected later. The downside of this method, is that it will become tedious to place the roof panels that are under G.

Part	Qty
G2	1
S3	52
S4	52
W1	4
W2	4
Y1	1

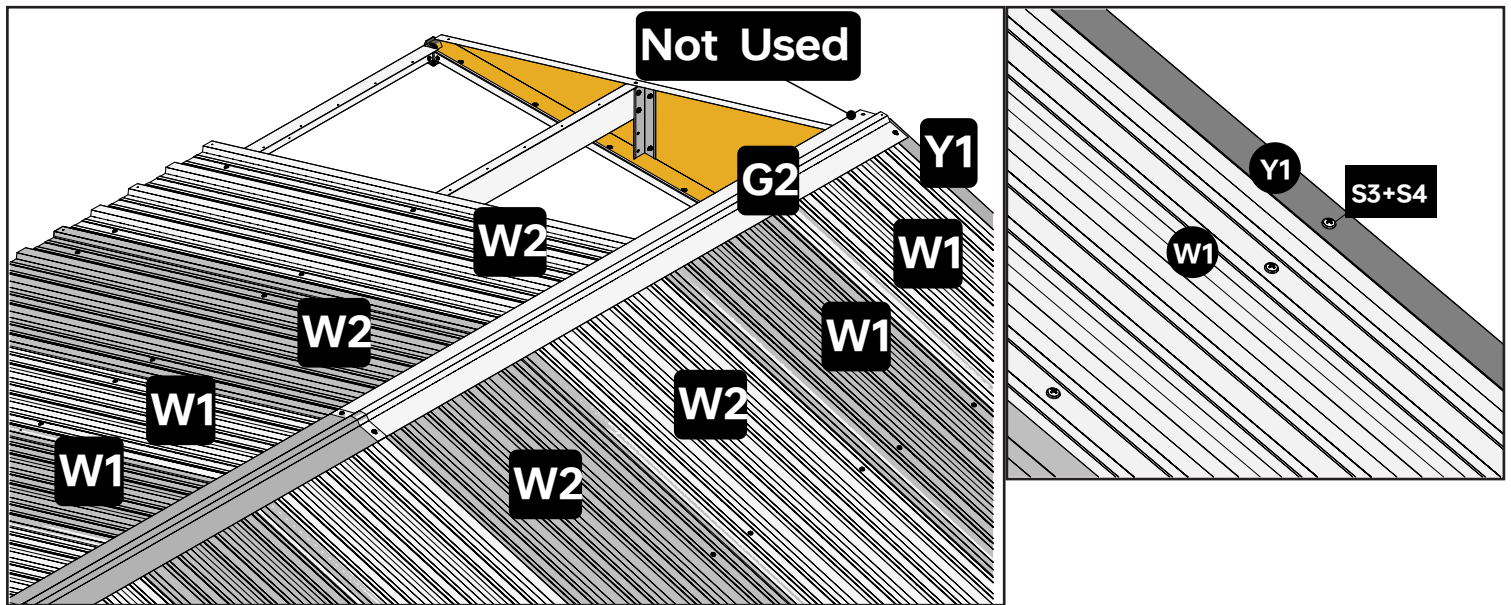
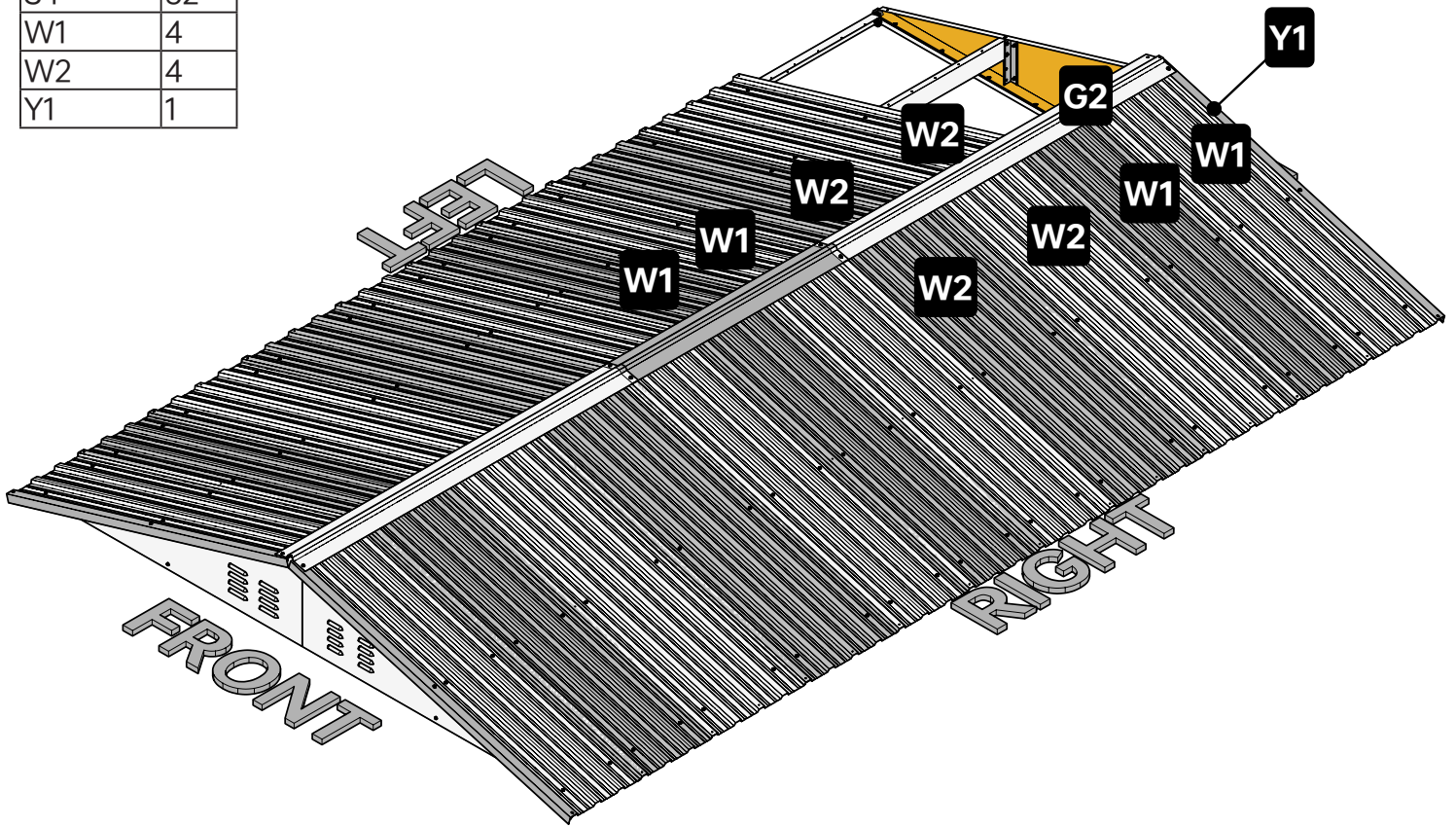

**NOTE**

For this step, place the end of G2 with three holes at the back side of the shed.

Part	Qty
S3	14
S4	14
W1	1
W4	1
Y4	1

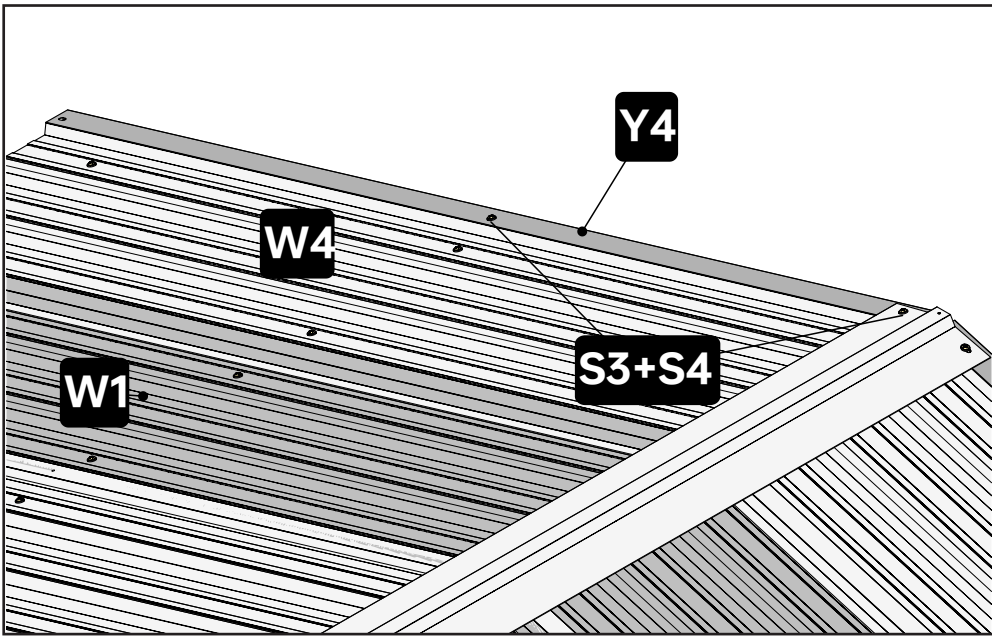
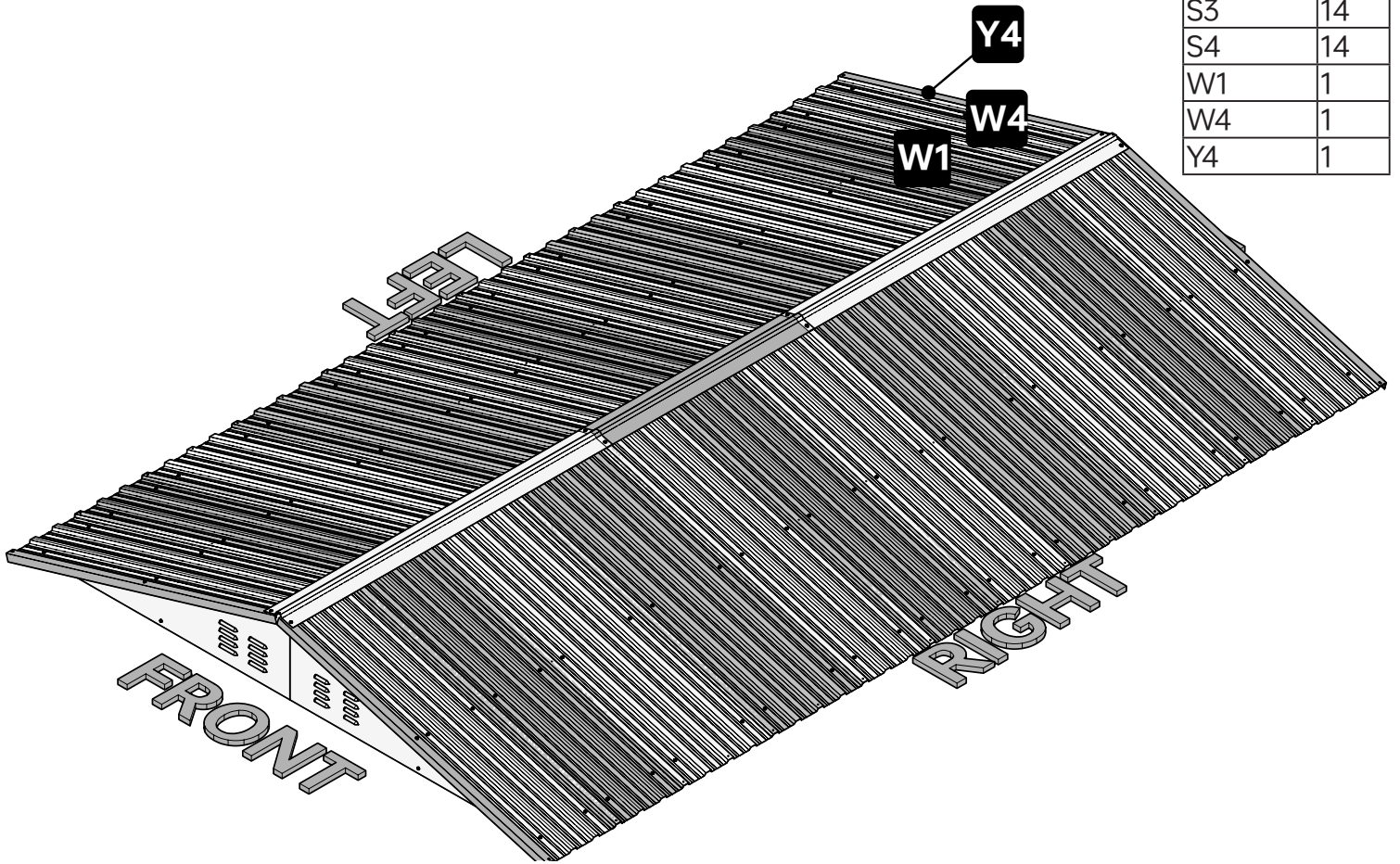

Part	Qty
D	2
E	4
S3	14
S4	14
Y2	2
Y3	2
Y5	2

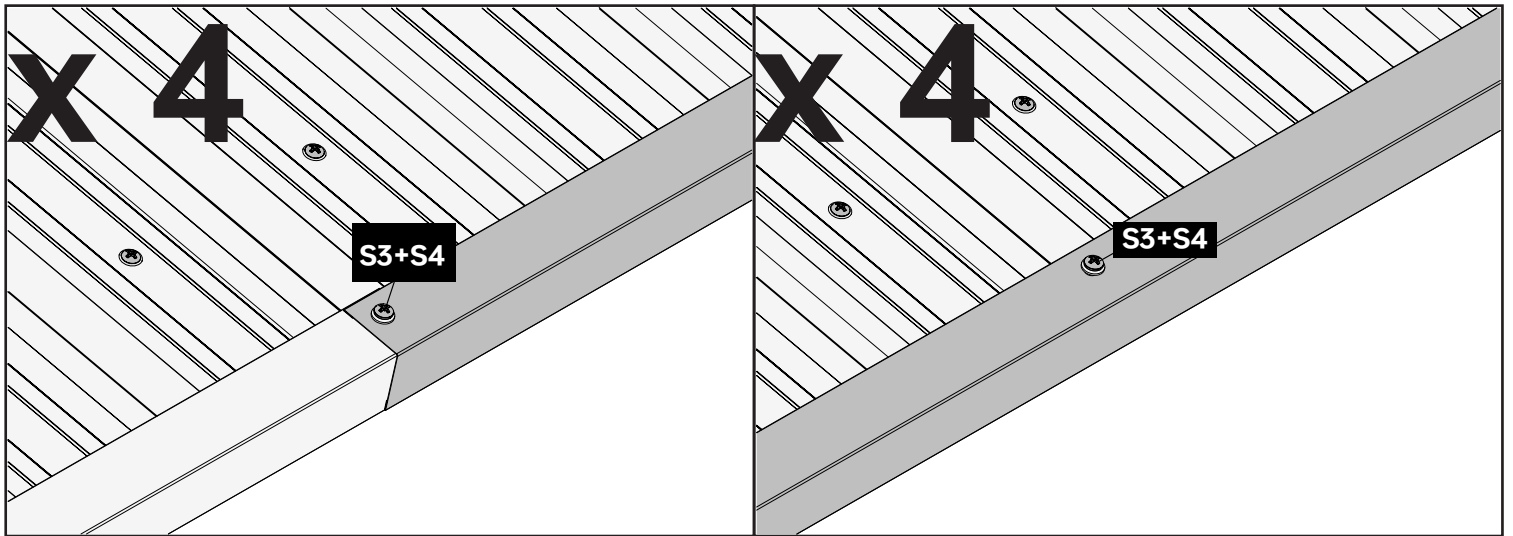
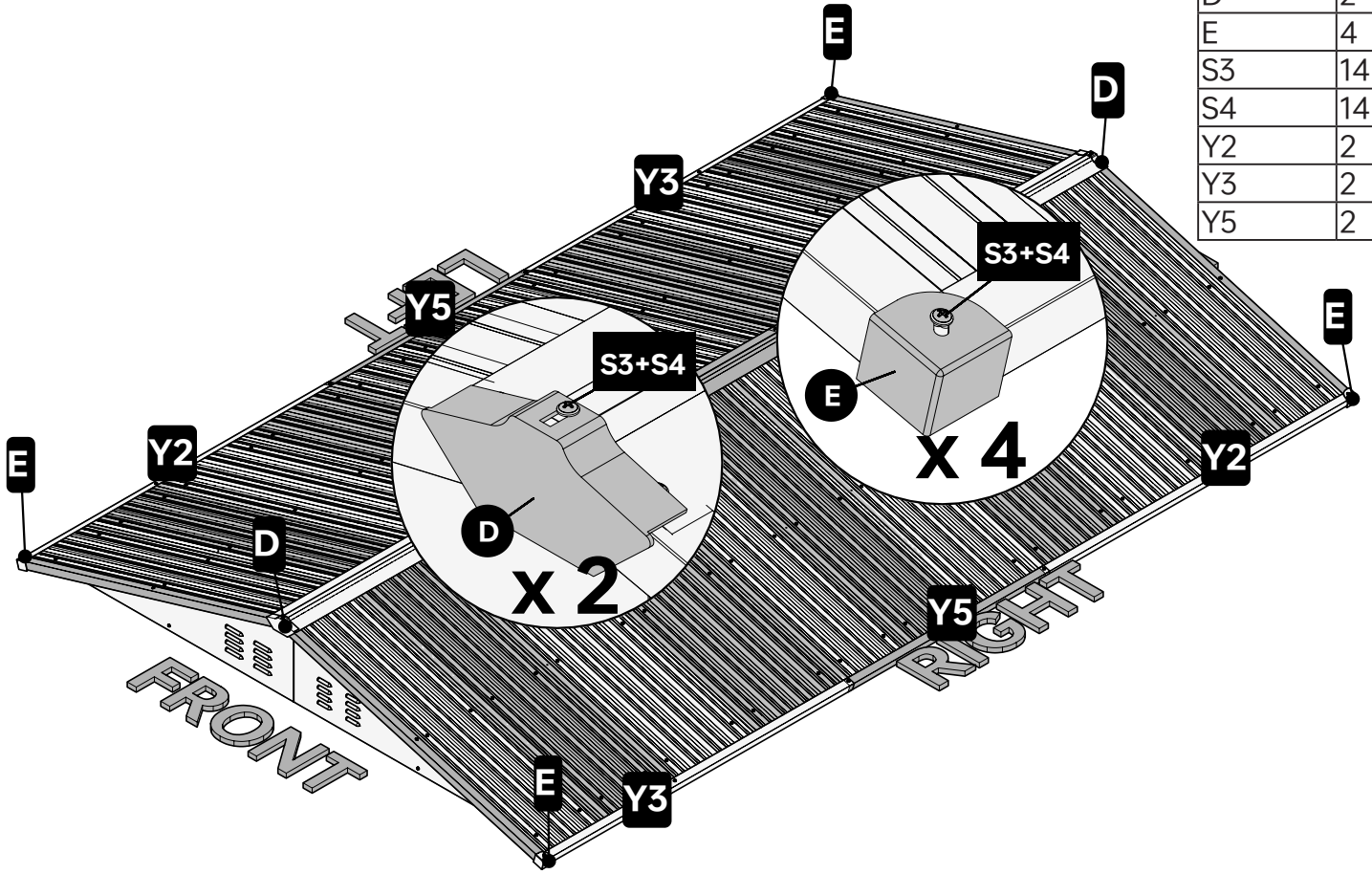

**NOTE**

The smaller screw holes left unused on roof panels are used here.  
 For Y1~Y5 it does not matter which one is layered on top.

# 07 Doors

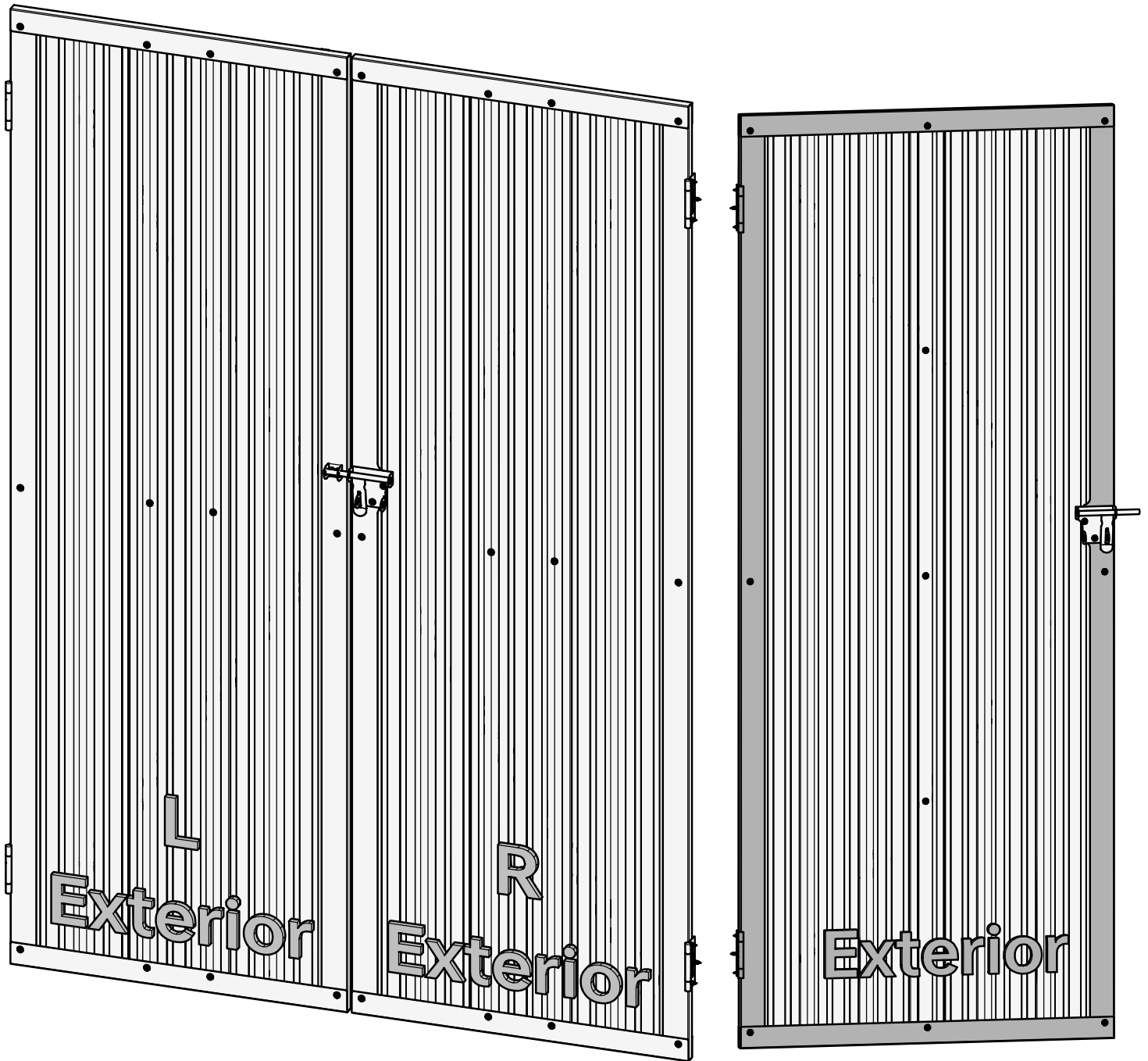

## IDENTIFY THE INTERIOR AND EXTERIOR SIDE OF PANELS.

**Interior Side:** This side is always light gray, providing a uniform look inside your shed, regardless of the exterior color you choose.

**Exterior Side:** This is the side that showcases the color you selected for your shed, facing outward.

In the first few steps of this chapter, we will be using the interior and exterior mark to help you understand what is going on. L and R stand for Left Door and Right Door

Part	Qty
M8	4
S1	4
S2	4
S4	4

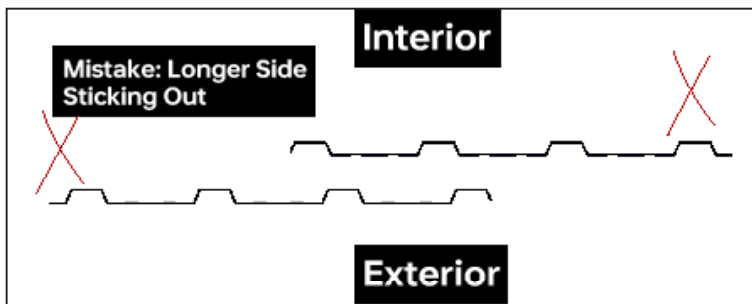
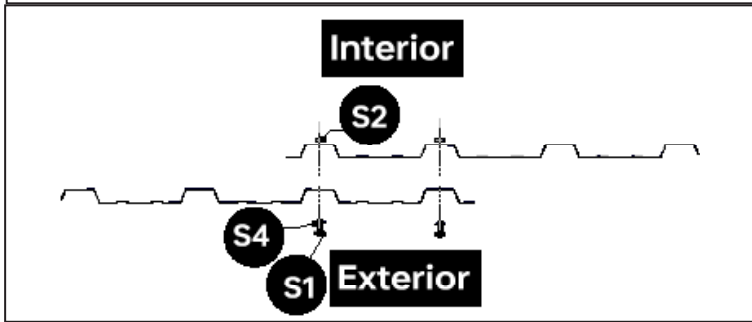
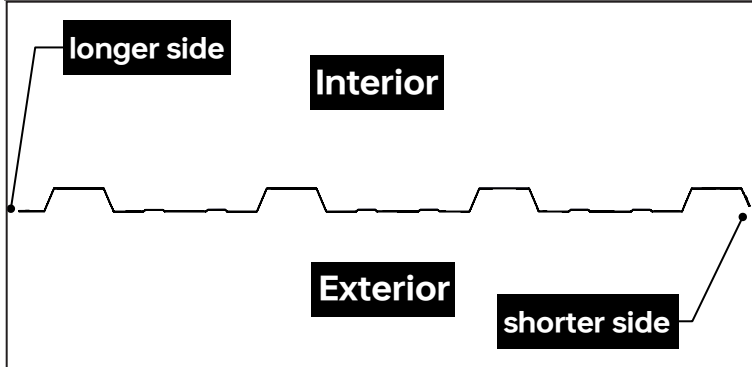
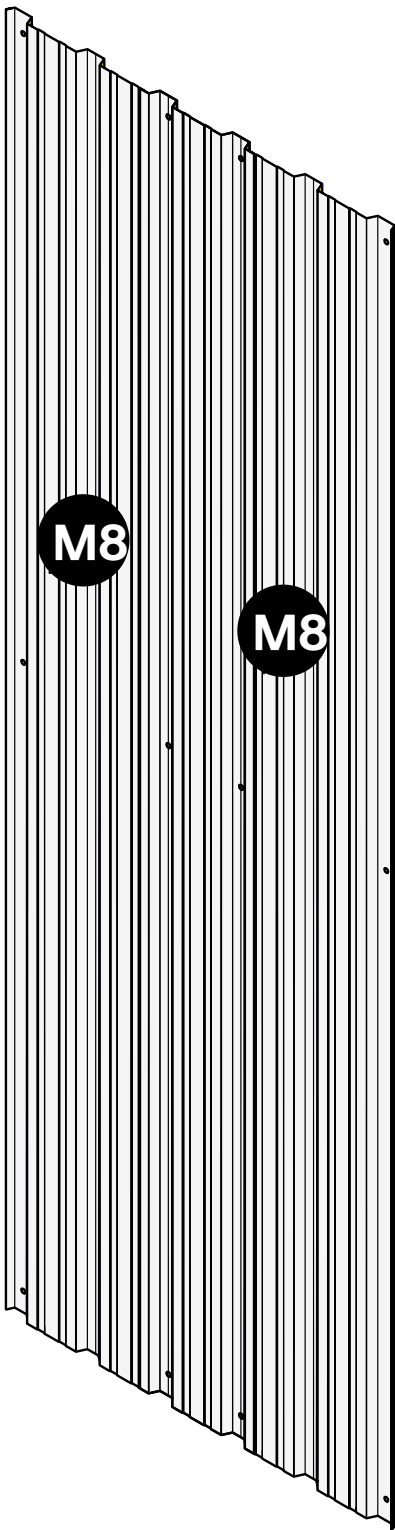

**NOTE**

Door panel M8 is stacked differently compared with wall panels and roof panels. You will need to stack an additional groove of M8 with another M8, as shown above. Use two sets of S1+S2+S4 to connect two M8. You will need to stack two sets of M8 for two doors.

Note that similar to wall panel Q1, M8 does not have a symmetrical design either. Take a look at the cross section of M8, you will find a longer side and a shorter side. When stacking the two M8 together, make sure to leave the shorter side sticking out. It does not matter which M8 is stacked on top.

Part	Qty
LK1	1
LT	2
M9	2
M8	2
M2	1
M3	1
M3S	1
M4L	1
S2	10
S3	8
S4	12
S9	10

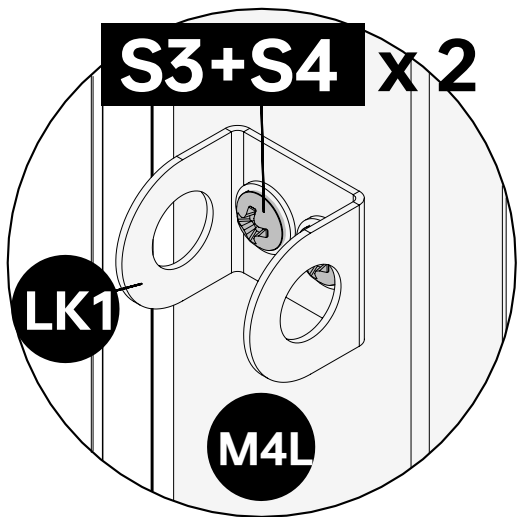
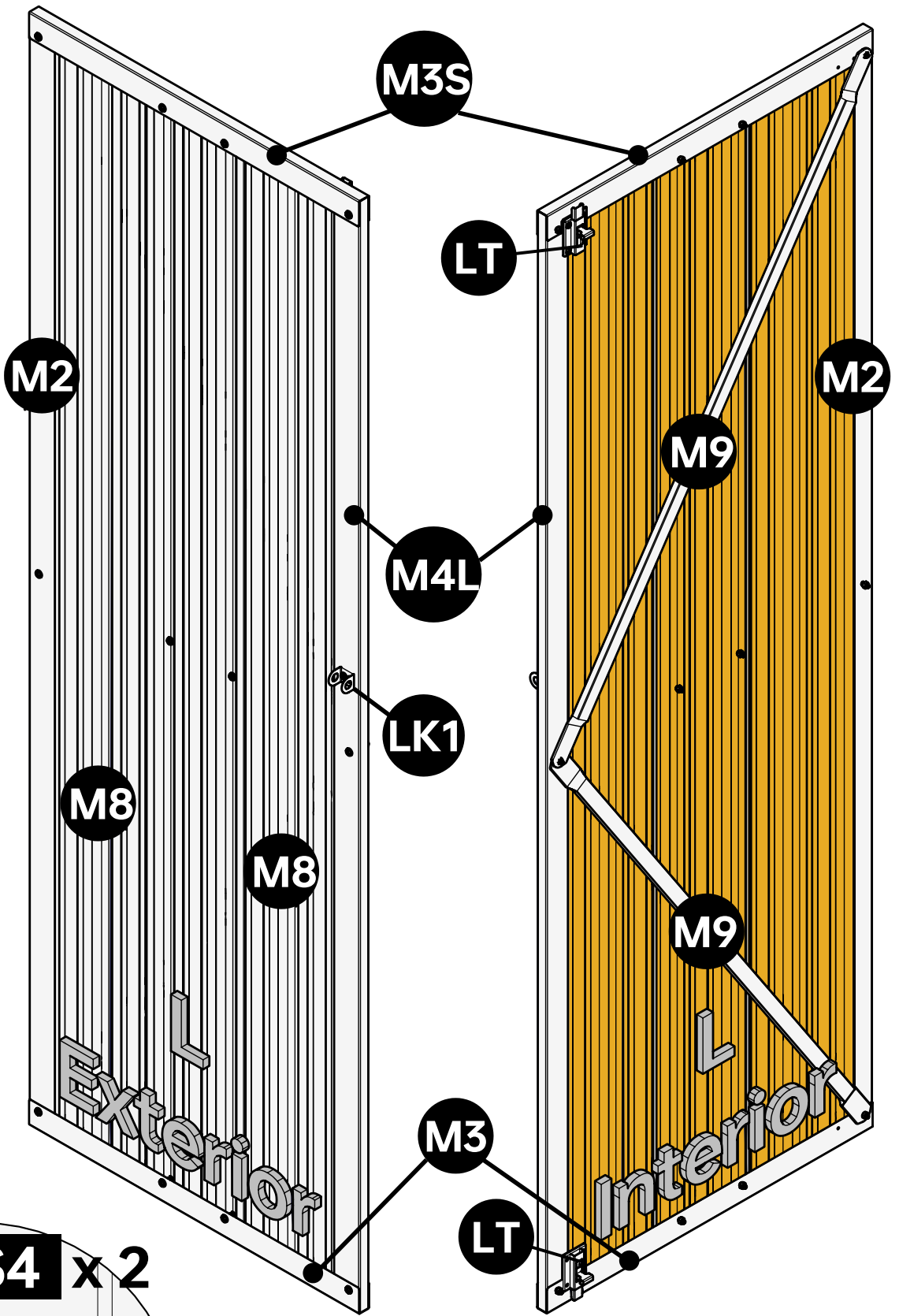

**NOTE**

This is the exterior and interior of the **same Left Door**.  
Continued on next page.

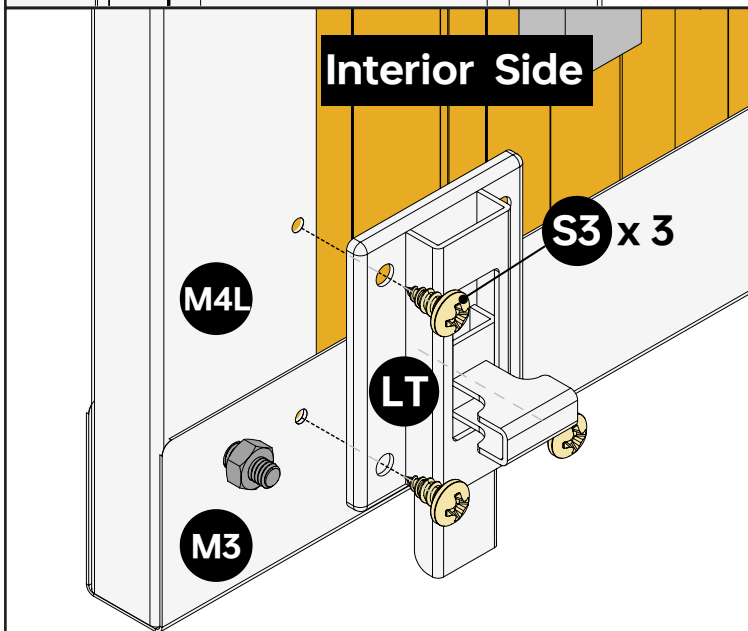
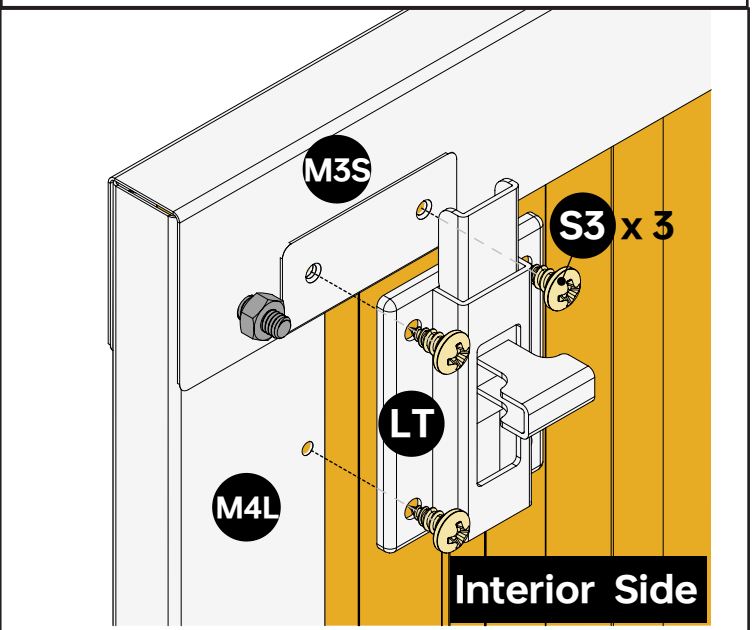
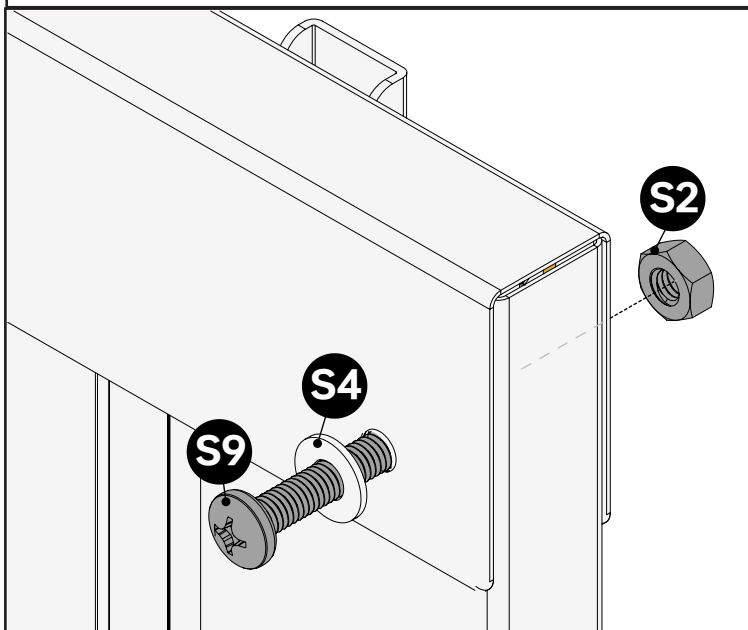
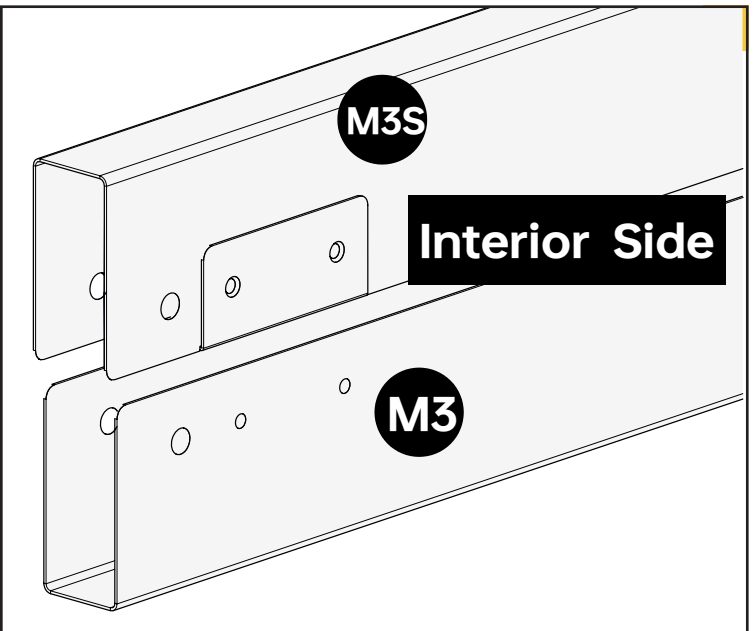
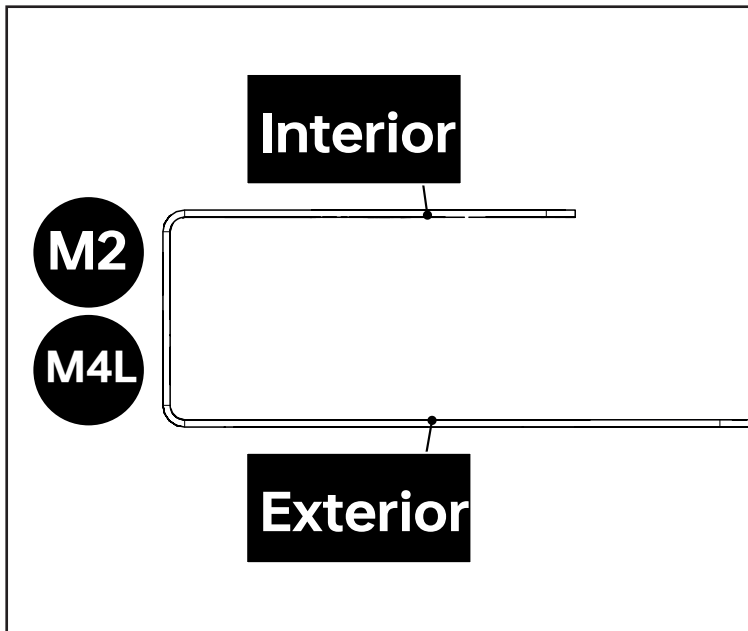

**NOTE**

Use S9+S4+S2 to connect M8 panel to M2~M4.

Use the shorter side of M2 as the interior side. For M3 and M3S, use the side with smaller screw holes as the interior side.

LT has a symmetrical design and you can use either end as the top/bottom end. Three out of the four screw holes on each LT will be used.

Part	Qty
LK2	1
M9	2
M8	2
M2	1
M3	2
M4R	1
S2	10
S3	3
S4	13
S9	10

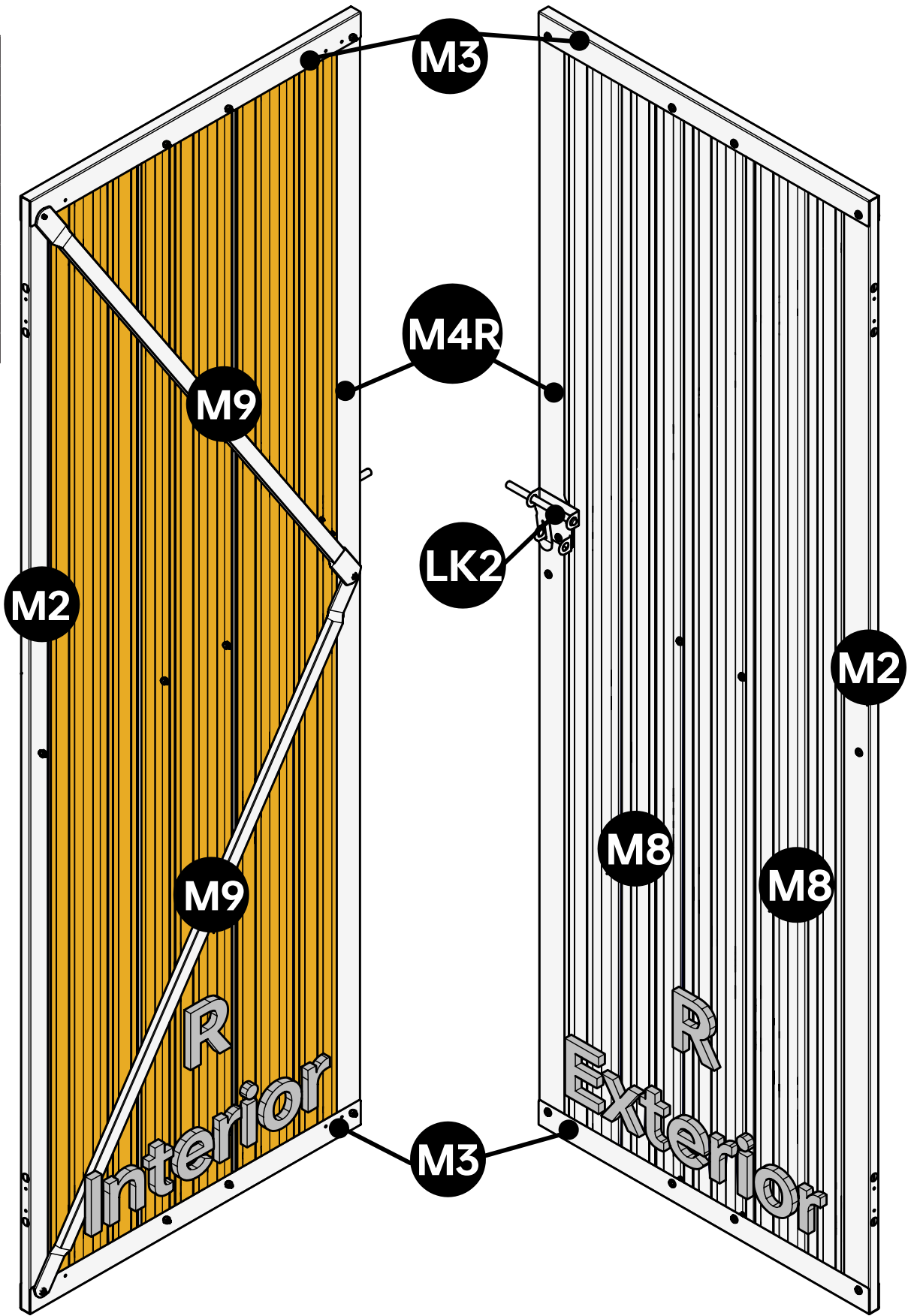

**NOTE**

This is the exterior and interior of the **same Right Door**.  
Continued on next page.

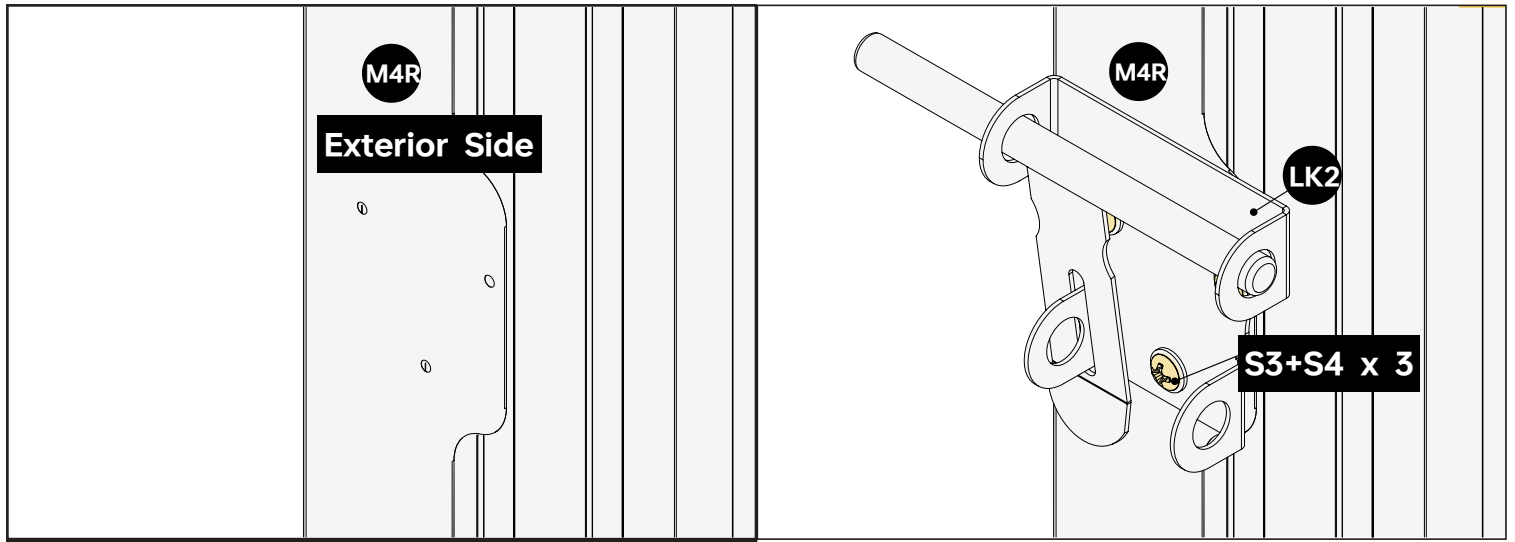

**NOTE**

Use S9+S4+S2 to connect M8 panel to M2~M4.

After this step is done, you will find some screw holes left unused on M3. This is normal.

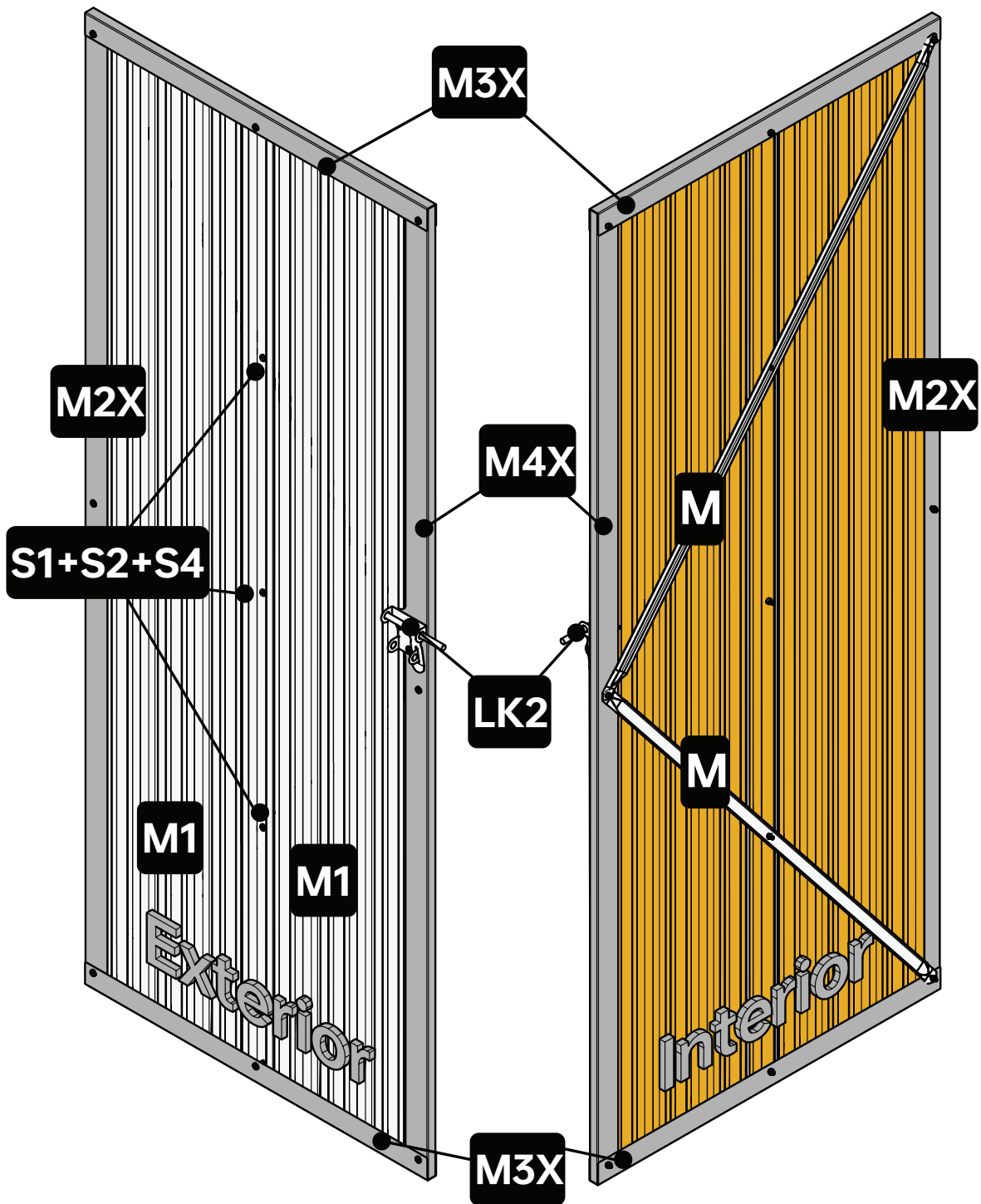

Part	Qty
LK2	1
M	2
M1	2
M2X	1
M3X	2
M4X	1
S1	3
S2	11
S3	3
S4	14
S9	8

**NOTE**

This is the exterior and interior of the same Left Door.

Continued on next page.

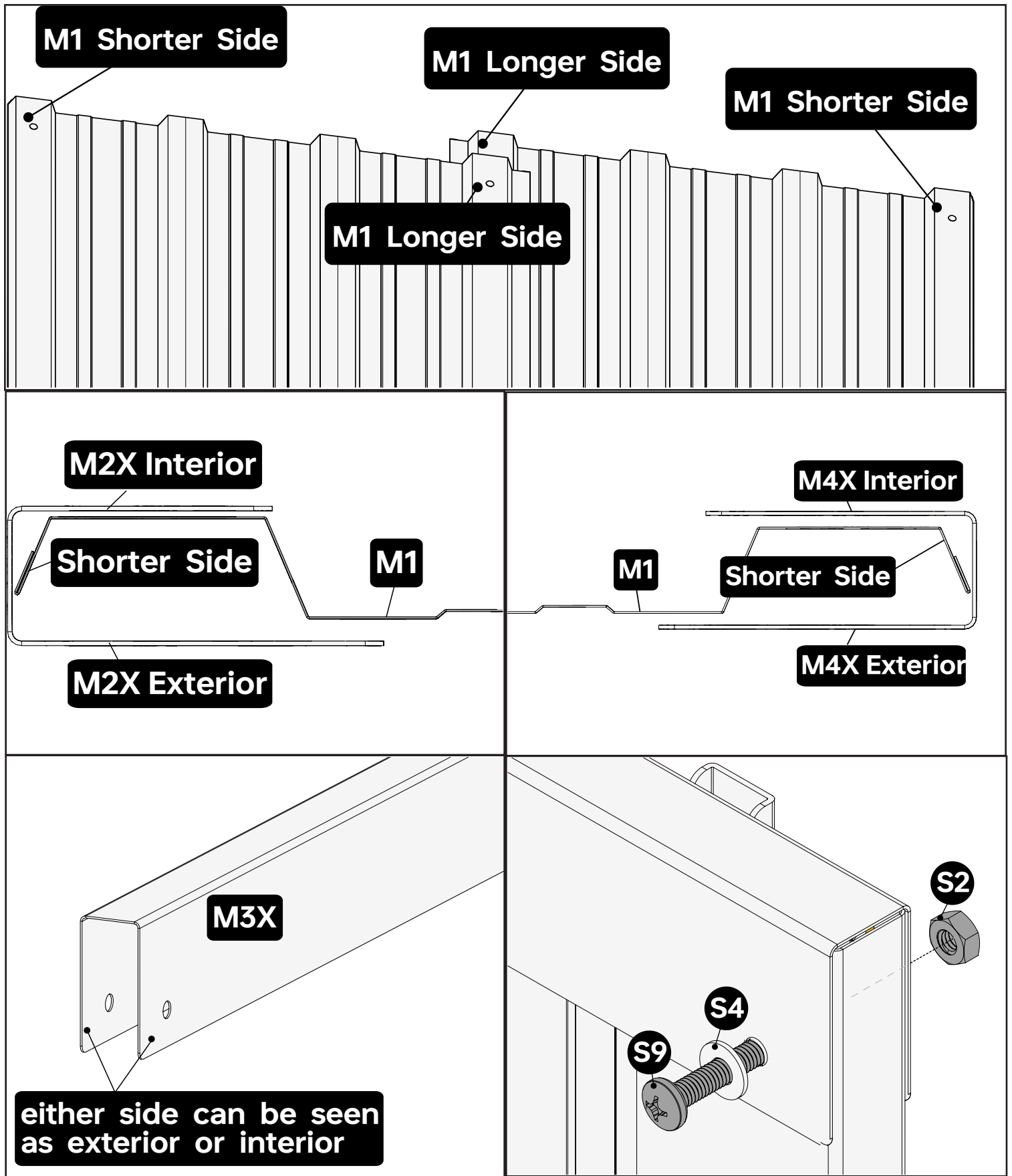

**NOTE**  
 Panel M1 does not have a symmetrical design. Take a look at the cross section of M1, you will find a longer side and a shorter side. When stacking the two M1 together, make sure that the shorter side of M1 is inside M2X and M4X.

Use the shorter side of M2X and M4X as the interior side. Either side of M3X can be used as exterior or interior side.

Continued on next page for this step.

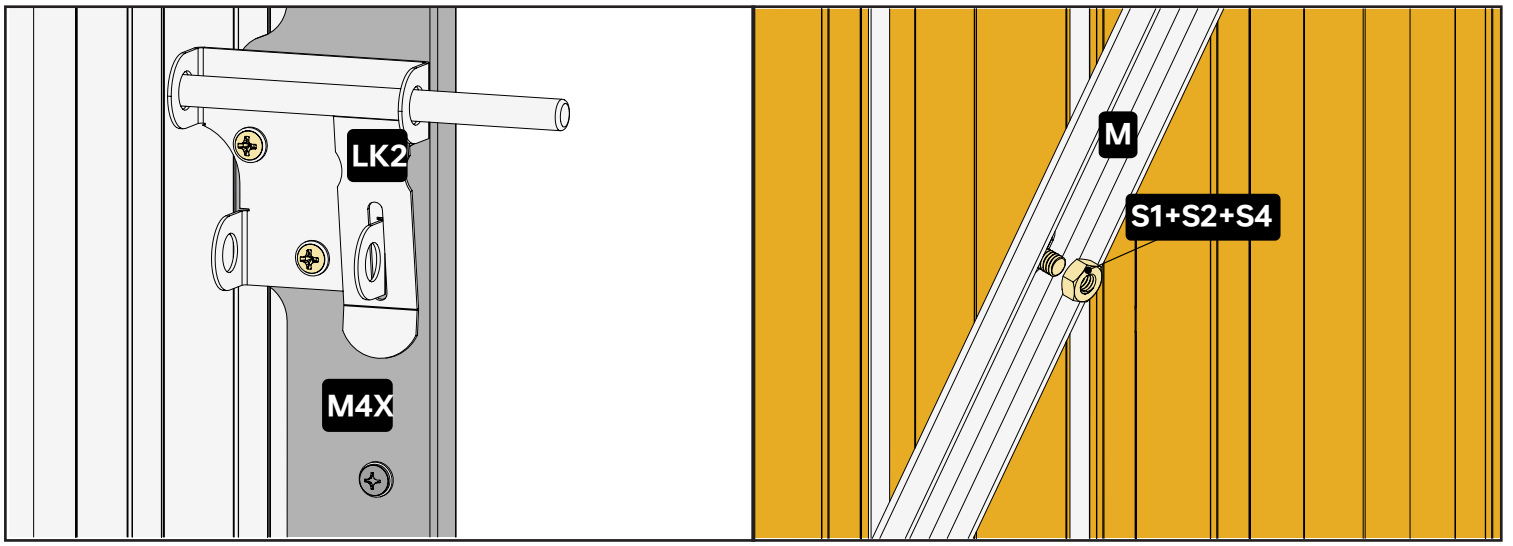

**NOTE**

Brace M used in this step is different from the Brace M9 used in previous steps. You will need S1+S2+S4 to connect Brace M to door panels.

Part	Qty
HG	6
S3	12
S10	6

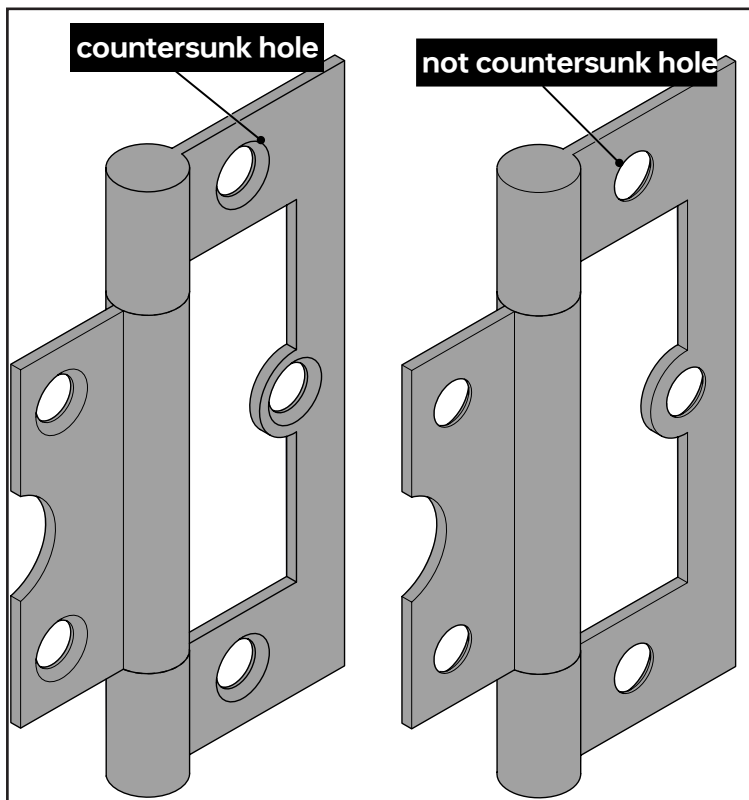
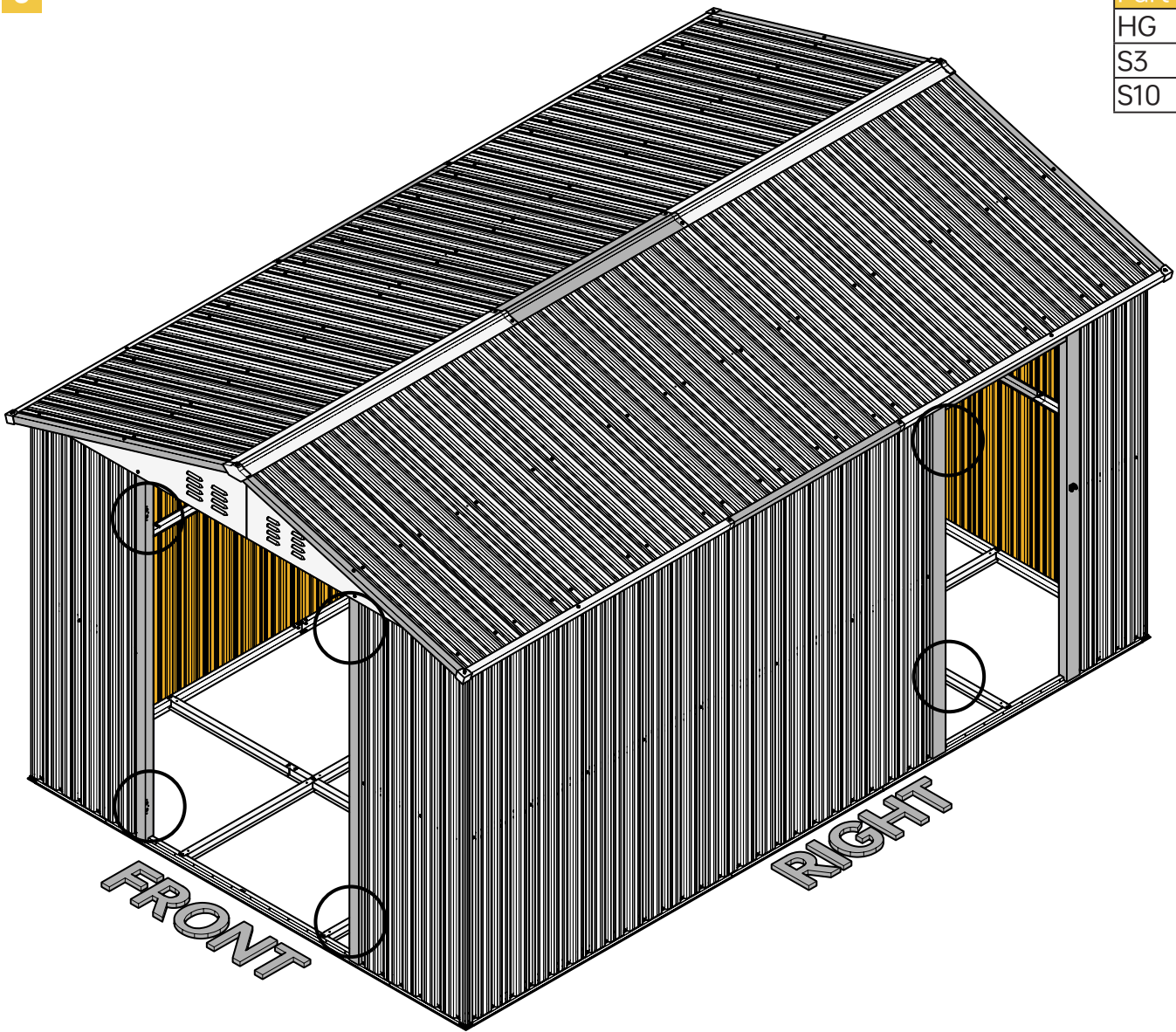
**NOTE**

Unfold the six hinges before using them. The Hinge HG has two sides, a side with countersunk holes and a side without.

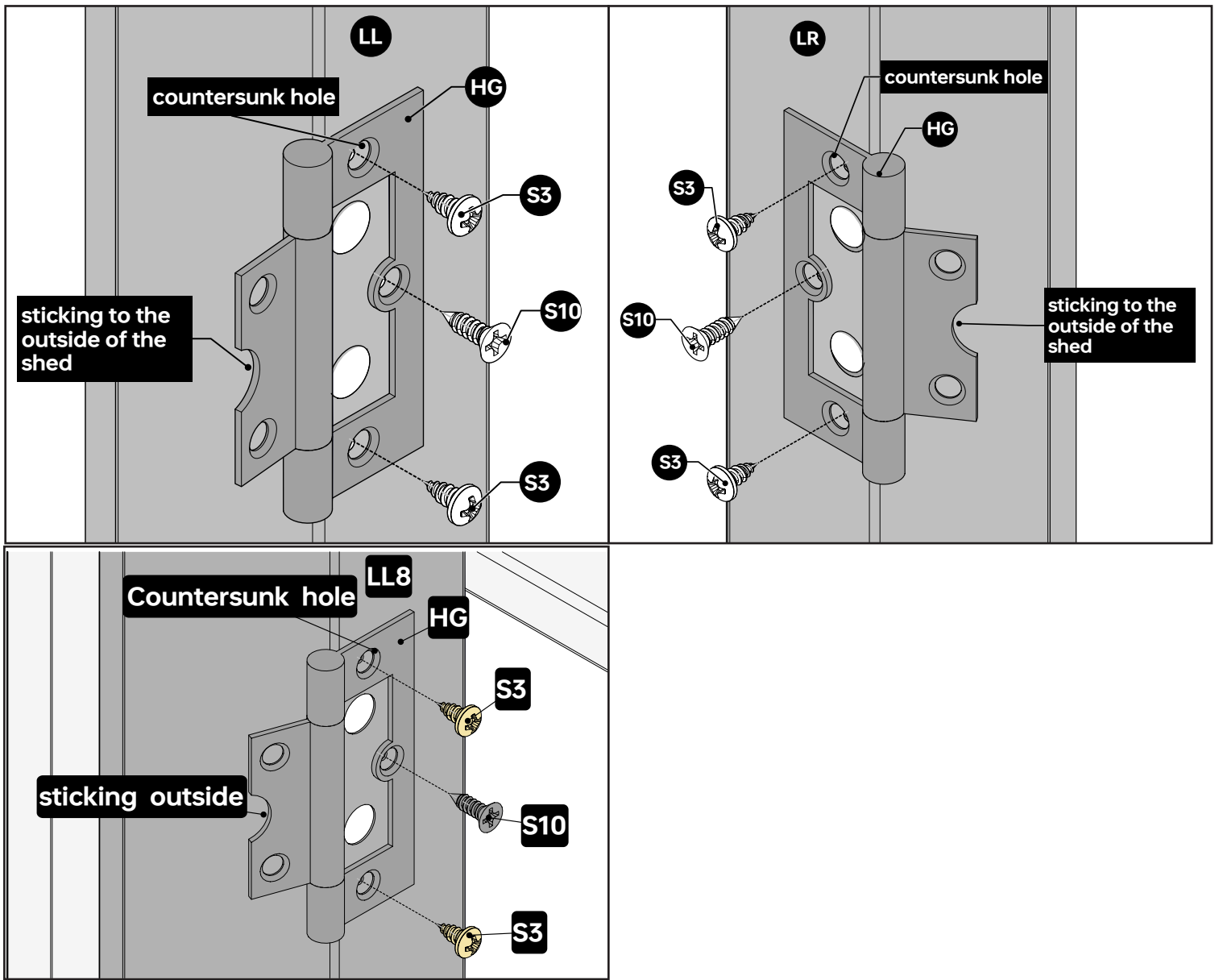

**NOTE**

Use two S3 and one S10 per hinge HG.

When attaching HG to LL, LR, and LL8, make sure the screws are going through the side with countersunk holes.

Also, after HG is attached to LL, LR and LL8, the semicircle opening on the hinge is sticking to the outside of the shed.

Six sets of Hinges are used in this shed. To improve readability of the manual, In this and the next step, only the Hinges at the top end of LL, LR and LL8 are shown.

**DO NOT USE S4 WITH HINGES.**

Part	Qty
S3	12

