

ASSEMBLY INSTRUCTION

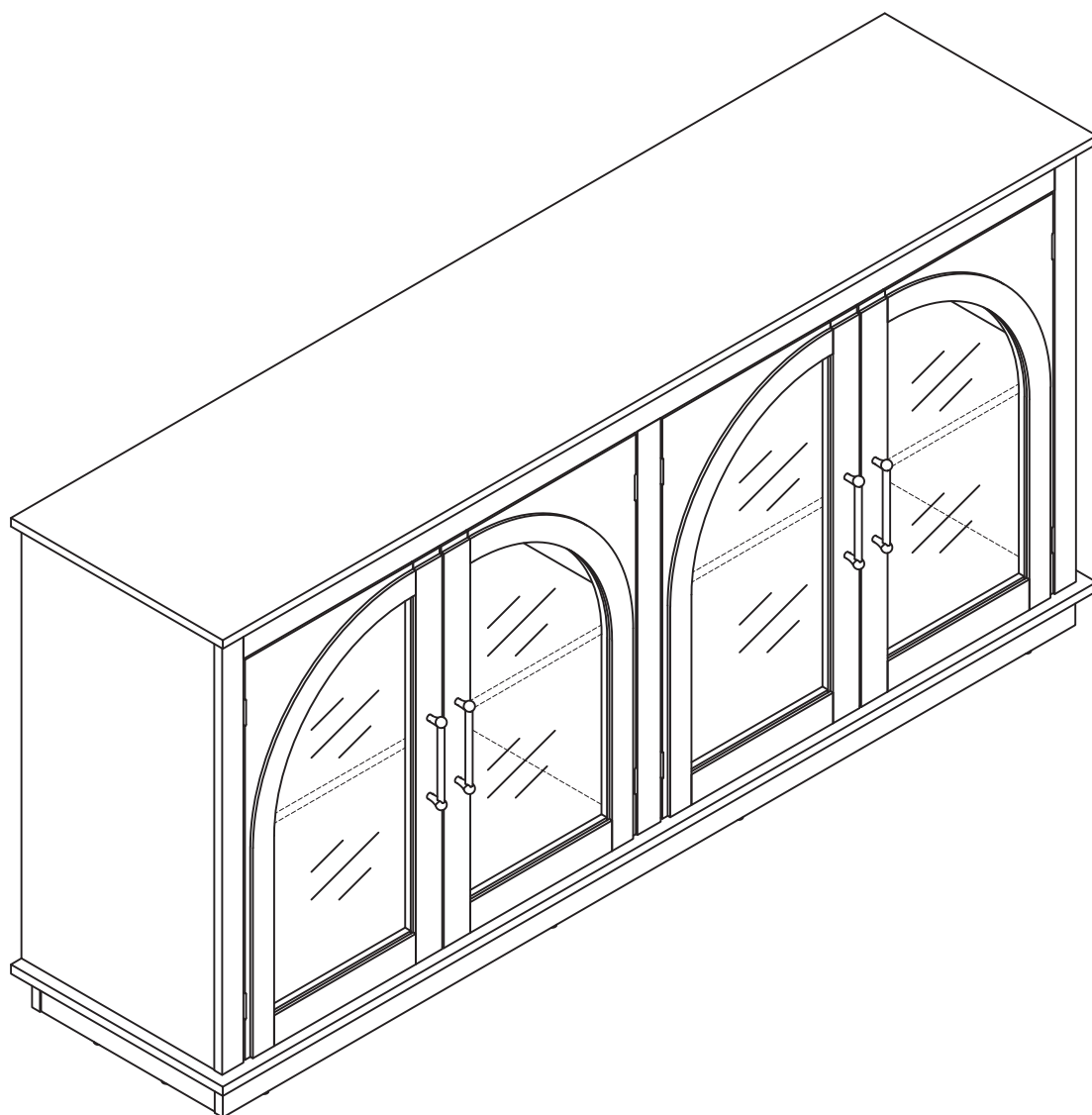

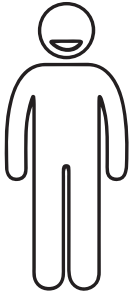

× 2

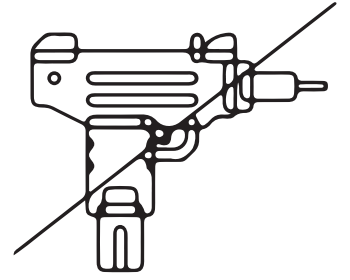
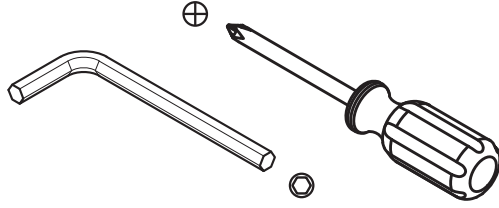

Before You Begin

Two people are recommended for the assembly.

Use the included tools.

If using a power tool, use low power and torque.

Installation of Eccentric Unit

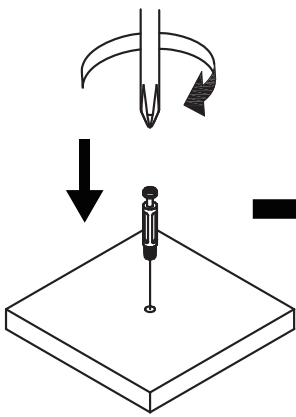
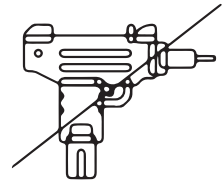
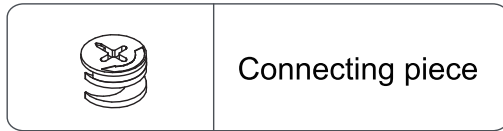

1

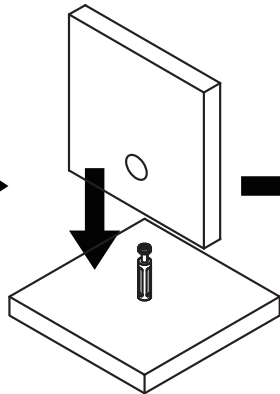

2

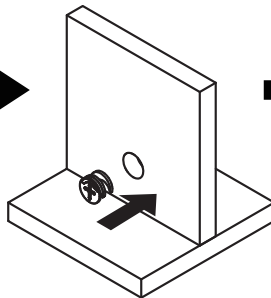

3

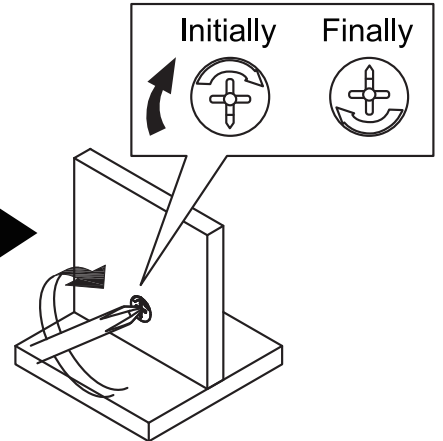



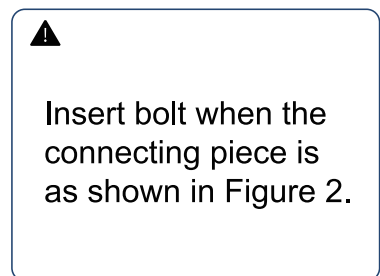
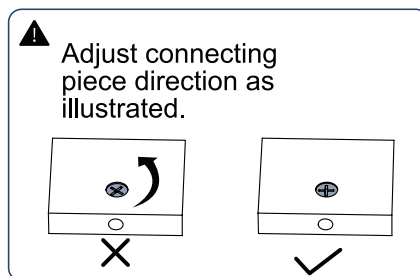
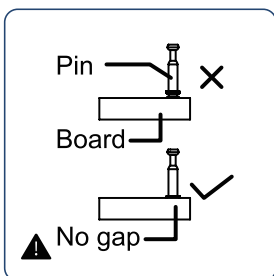

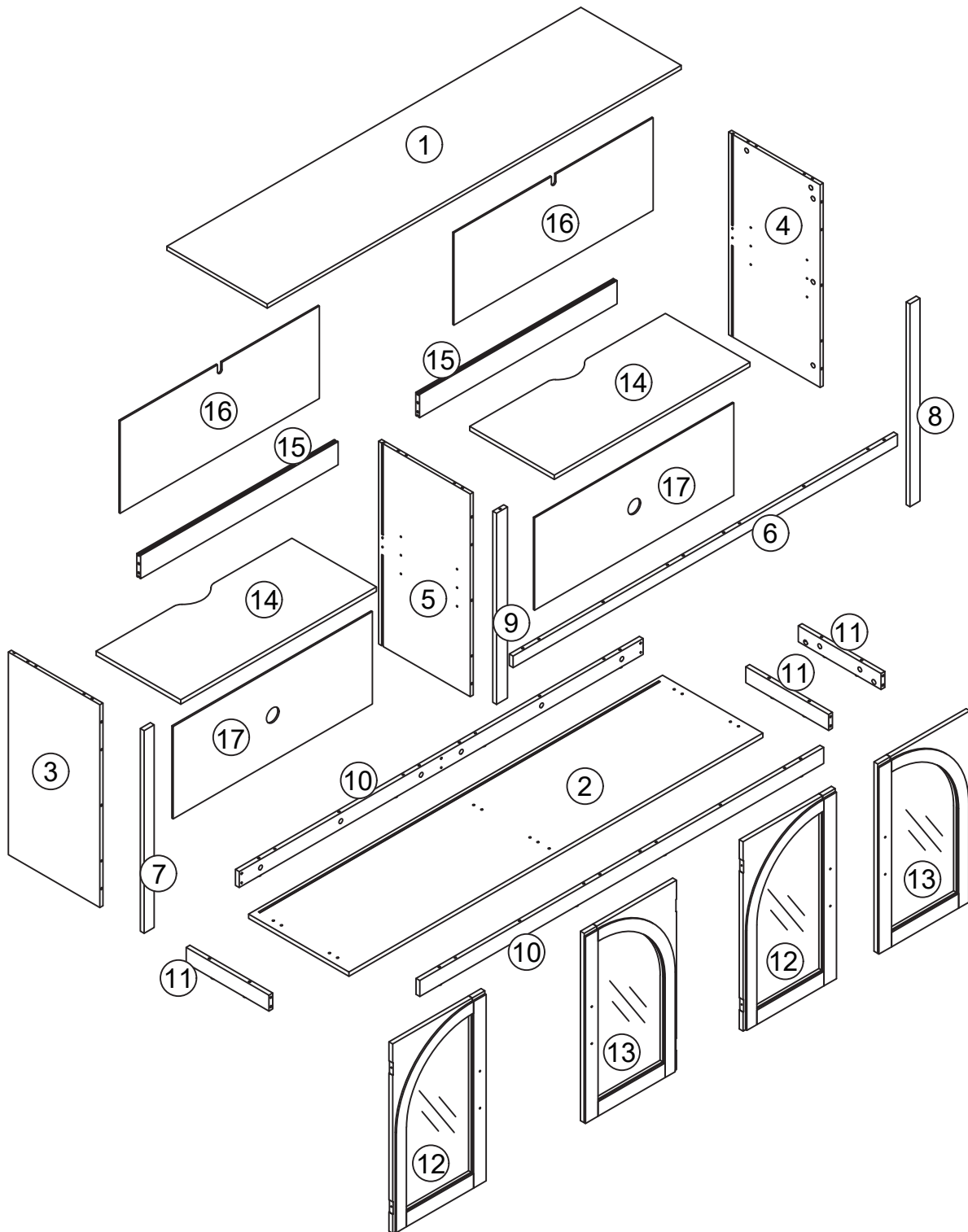







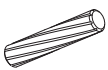



4





Package Contents: Hardware

Please count and verify all parts before assembly.

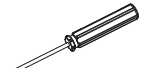
A x 53+5	B x 53+5	C x 38+3	D x 6+1	E x 64+6	F x 8	G x 8+1	H x 4	I x 8+1
								
Ø6x35mm	Ø15x10mm	Ø6x30mm	Ø5x38mm	Ø6xØ3x12mm				M4x25mm
J x 20+2	K x 24+2	L x 4	M x 2					
 J1	 J2	 L1	 M1	 M2	 M3	 M4		
Ø6xØ3x16mm	Ø20mm				Ø8xØ4x38mm			

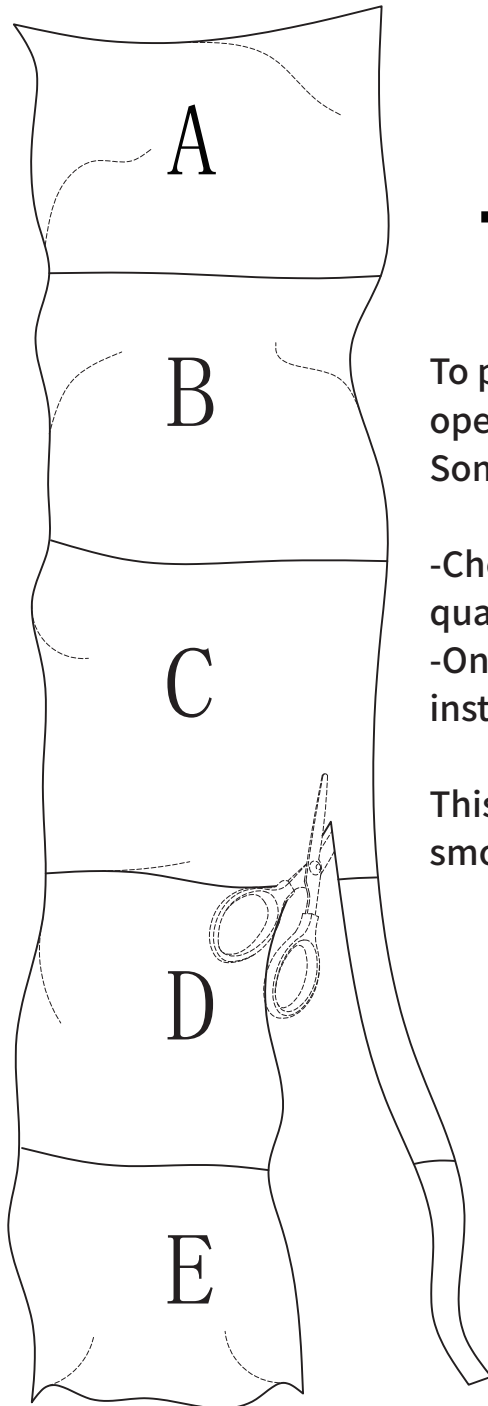
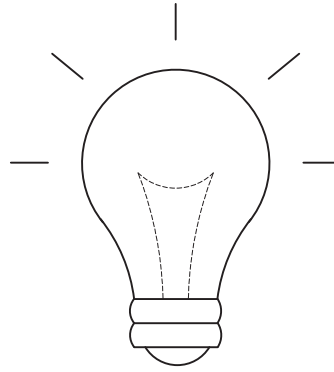

friendly reminder

To prevent confusion during installation, please do not cut open all hardware bags at once.
Some screws may look similar, so before starting assembly:

- Check each hardware bag and confirm that the type and quantity match the parts list in the manual.
- Only open each bag when it is needed for that specific installation step.

This will help keep the hardware organized and ensure a smoother installation process.

01

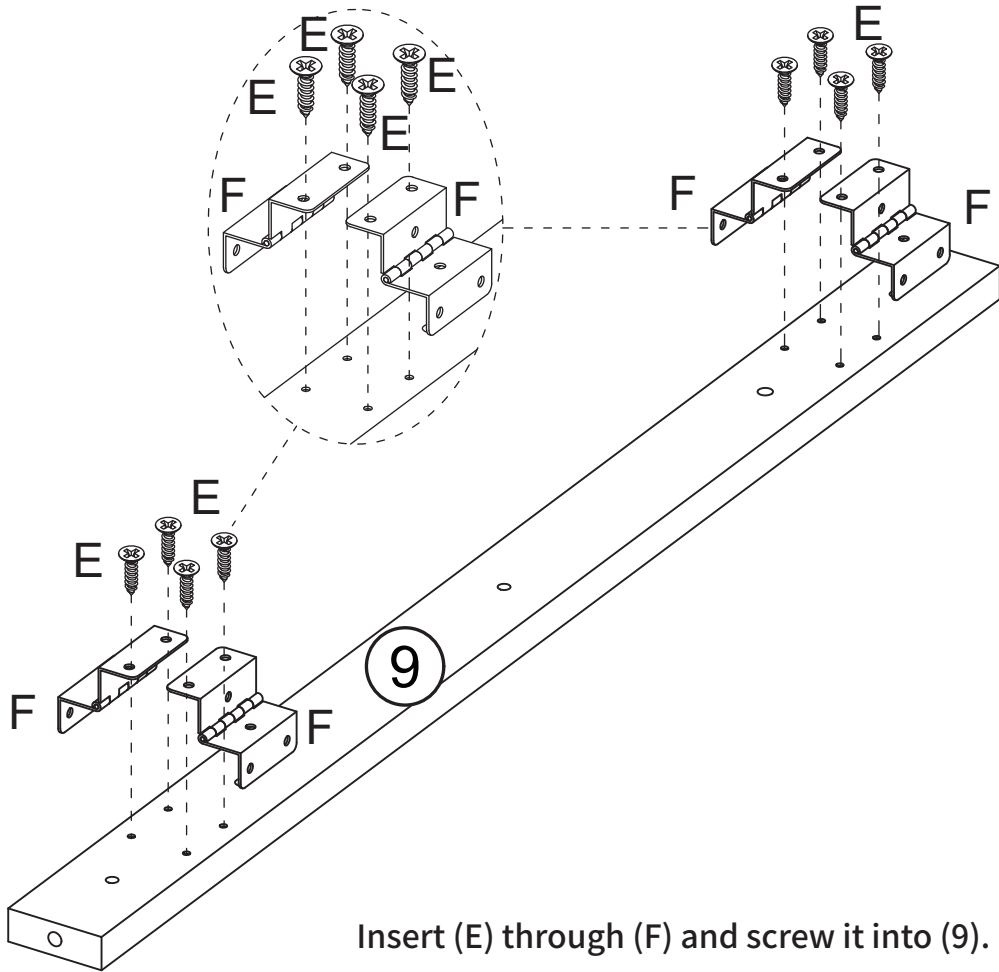

Insert (E) through (F) and screw it into (9).

E x 8

F x 4



02

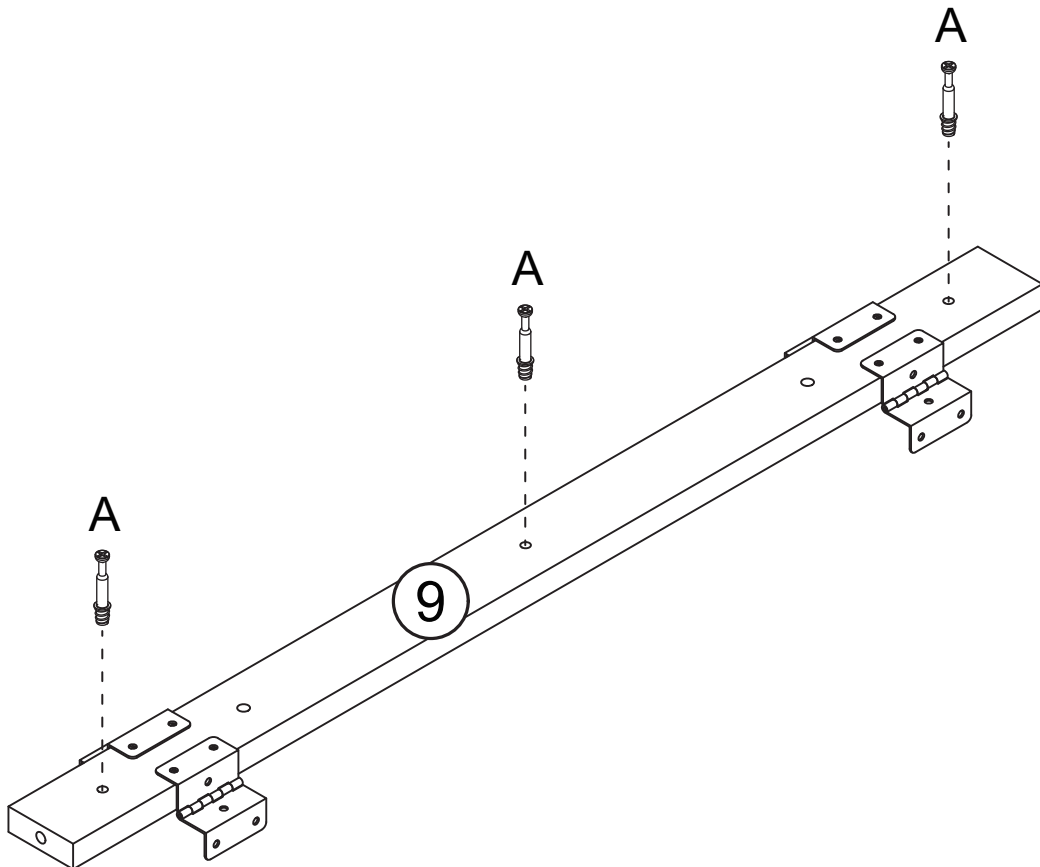

Flip (9) and screw (A) into the hole on it.

A x 3



03

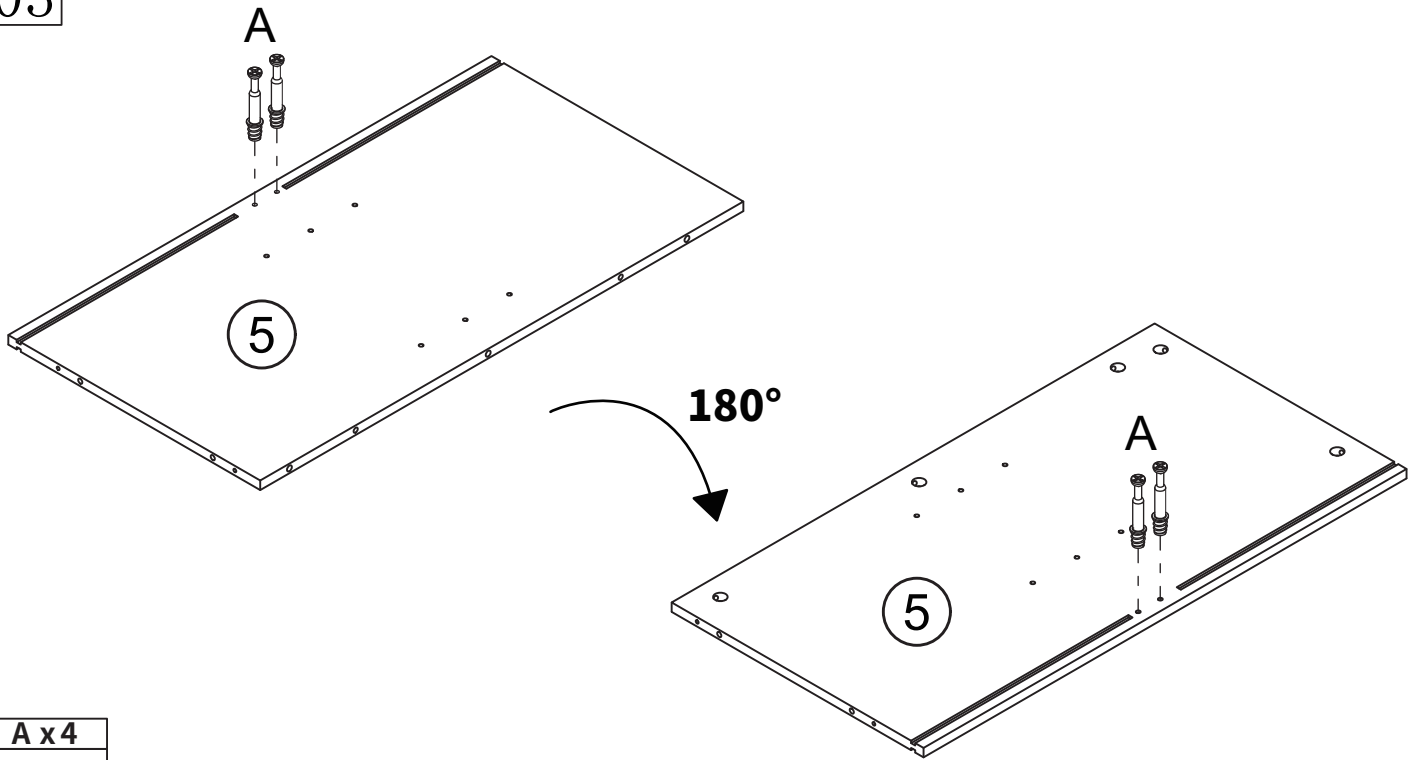

A x 4

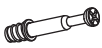

Screw (A) into the holes on both sides of (5).

04

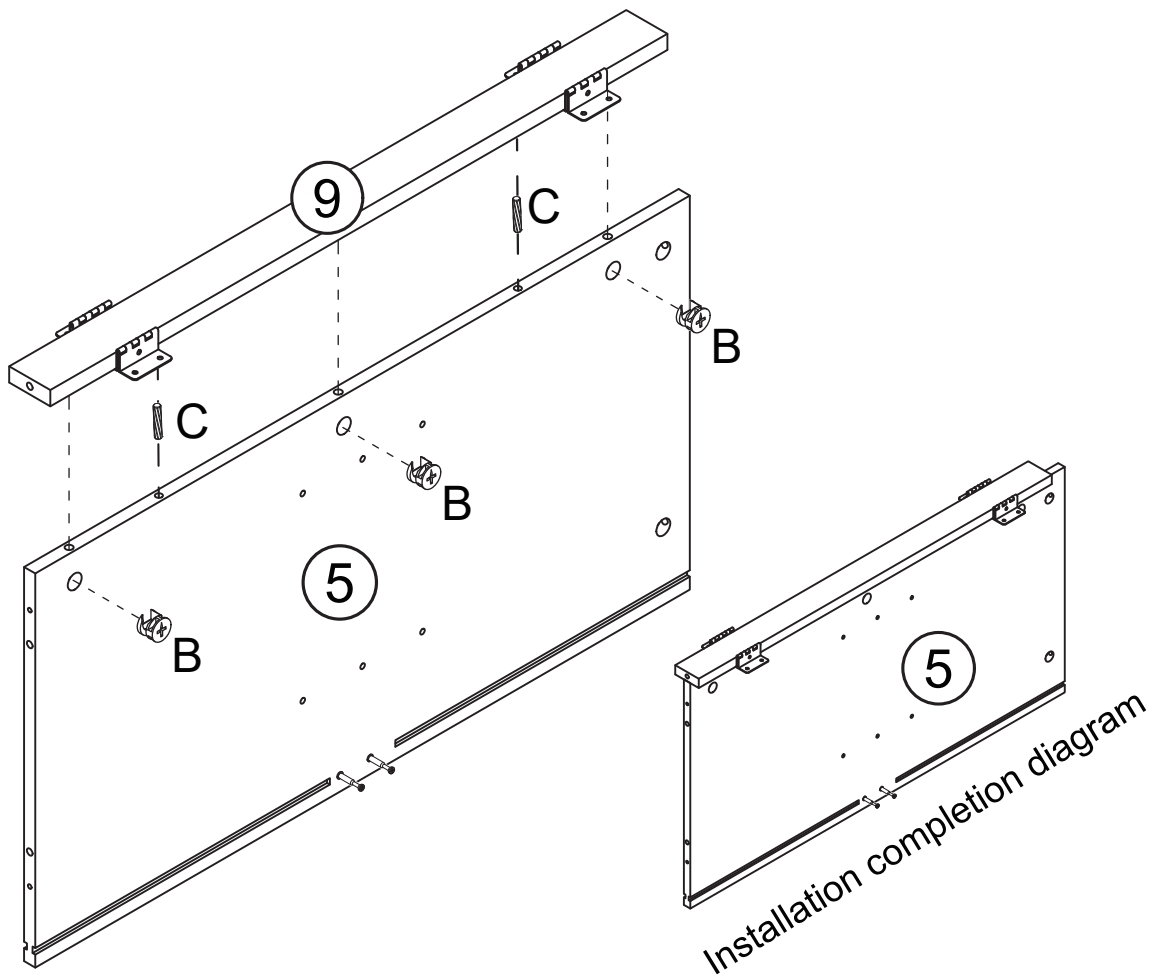

B x 3

C x 2



Ø6x30mm

Insert (C) into the side holes of (5).
Connect (9) to (5), then secure with (B).

Installation completion diagram

05

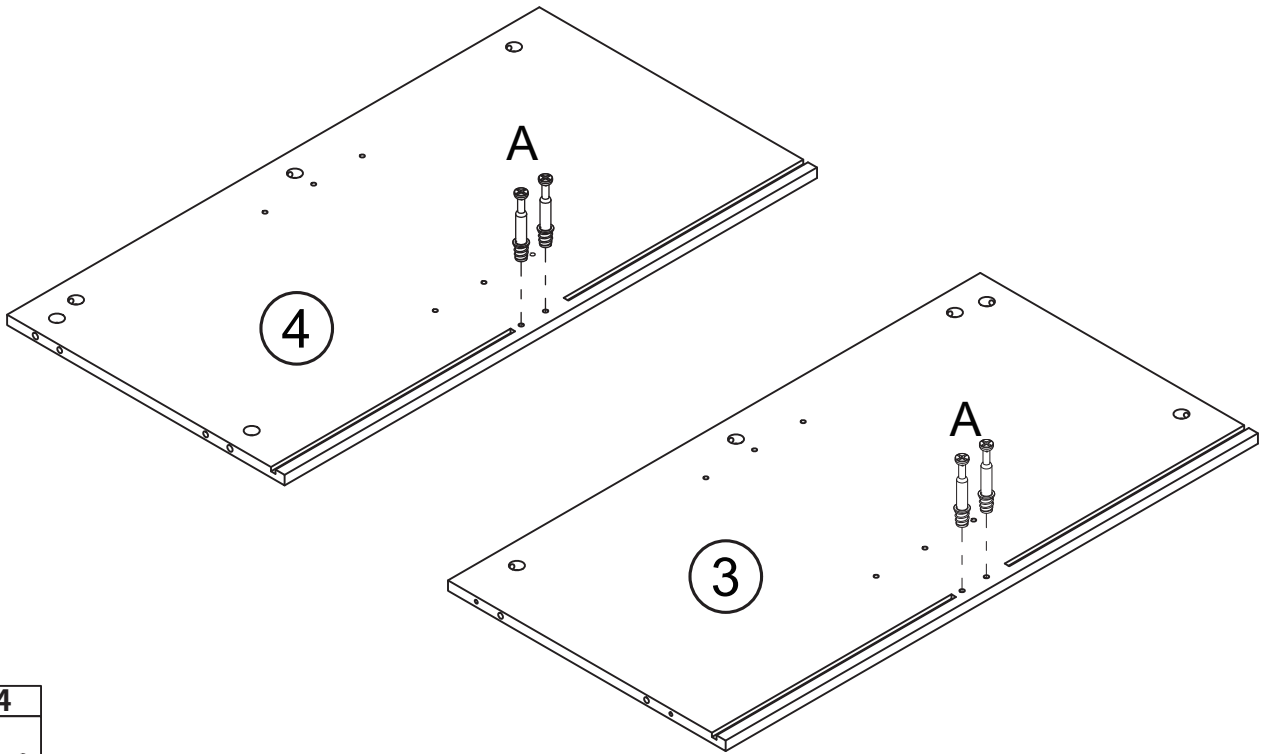

A x 4

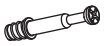

Screw (A) into the holes of (3) and (4).

06

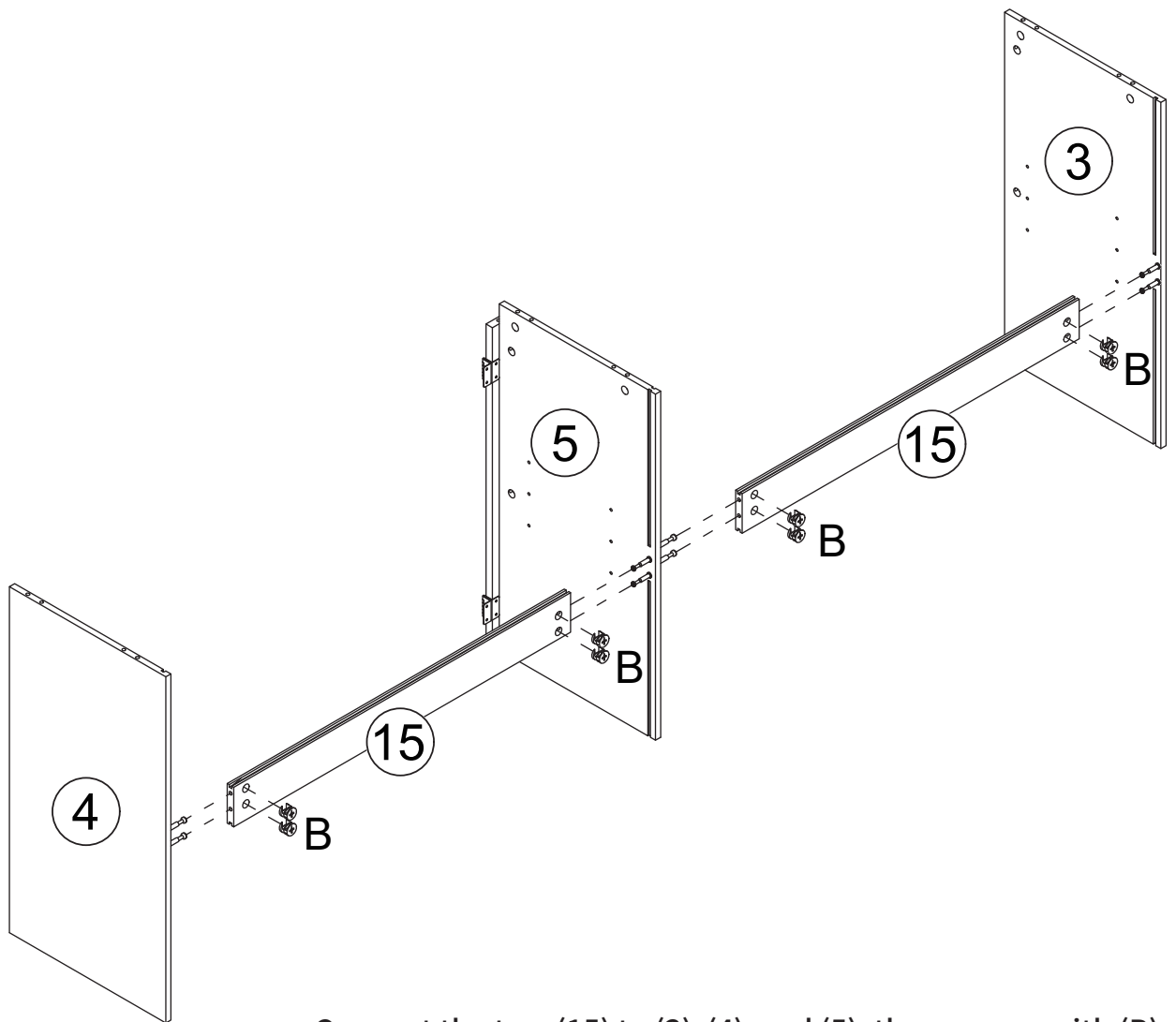

B x 8



Connect the two (15) to (3) (4) and (5), then secure with (B).

07

The thin plate needs to be fully inserted into the groove. If the insertion is not smooth, you can try pressing from the front or the back to make adjustments until the thin plate is fully inserted into the groove.

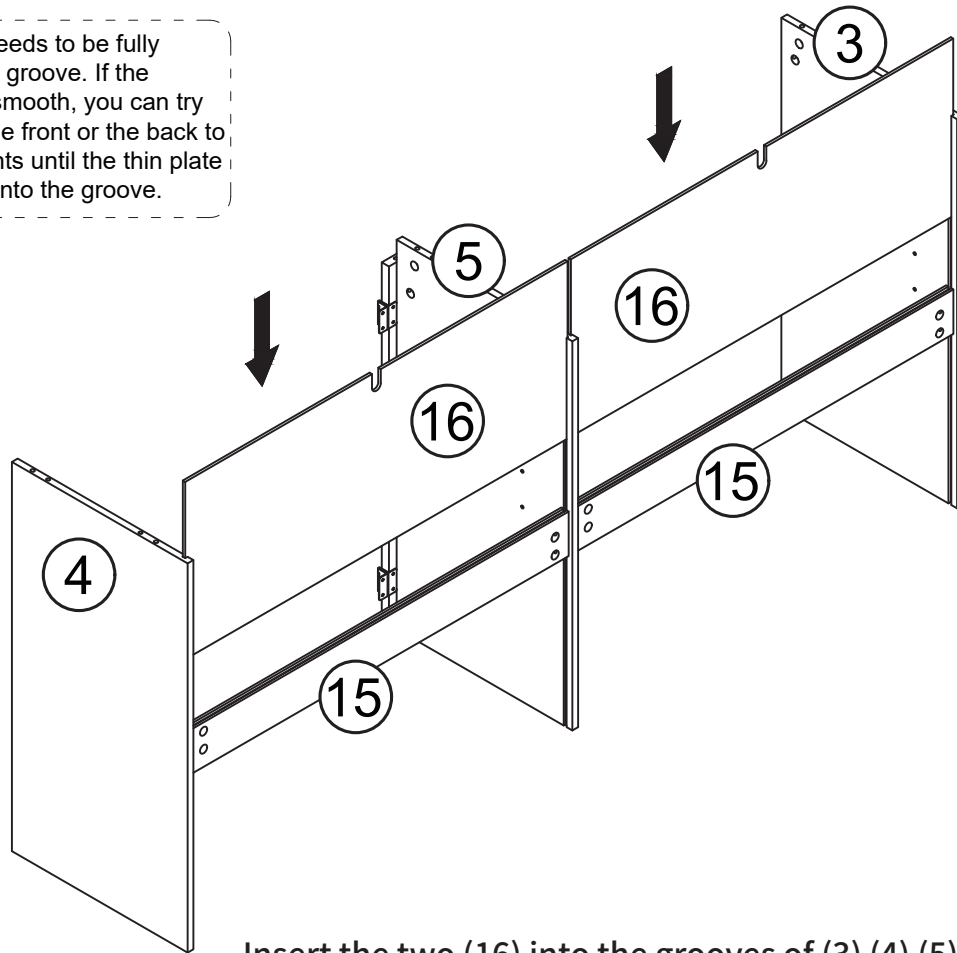

Insert the two (16) into the grooves of (3) (4) (5) and (15).



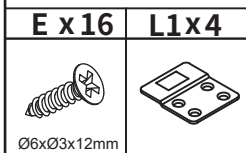
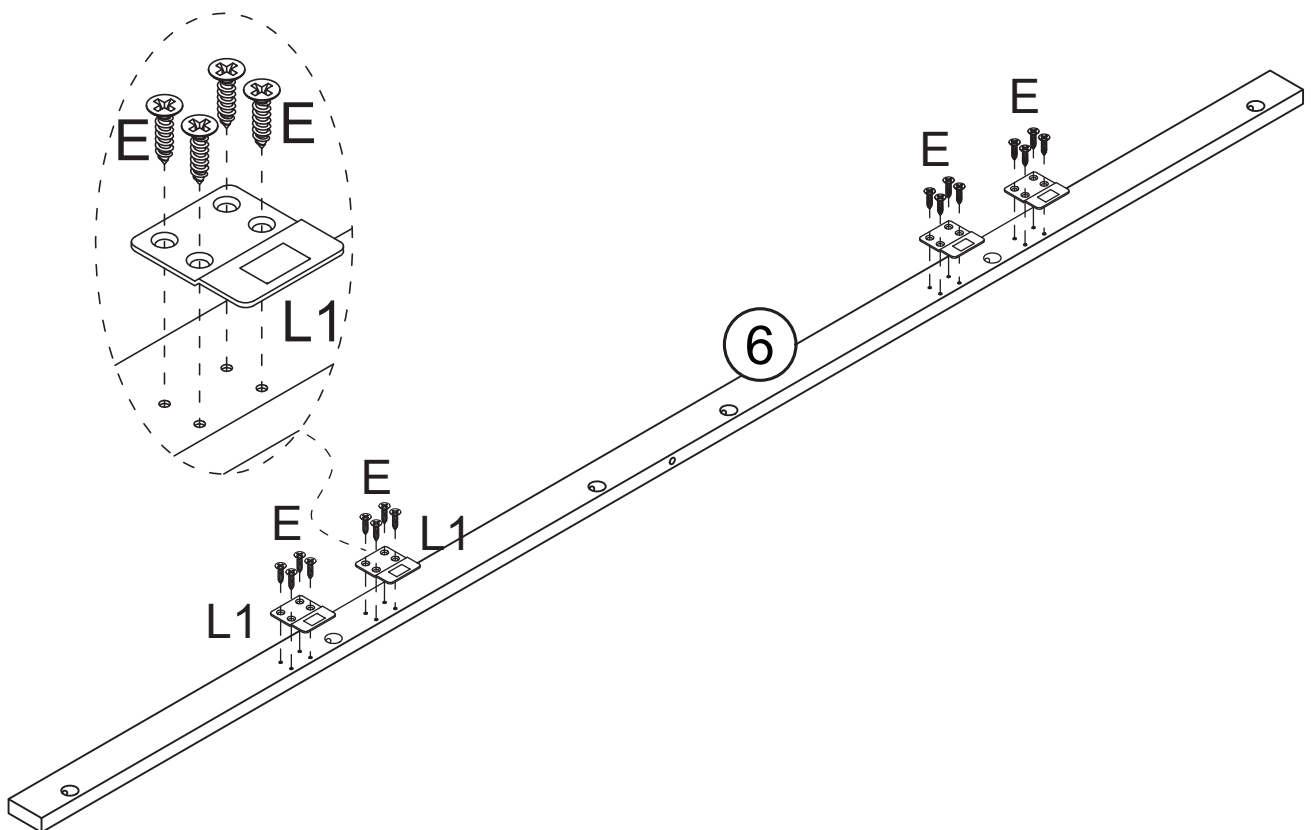

08

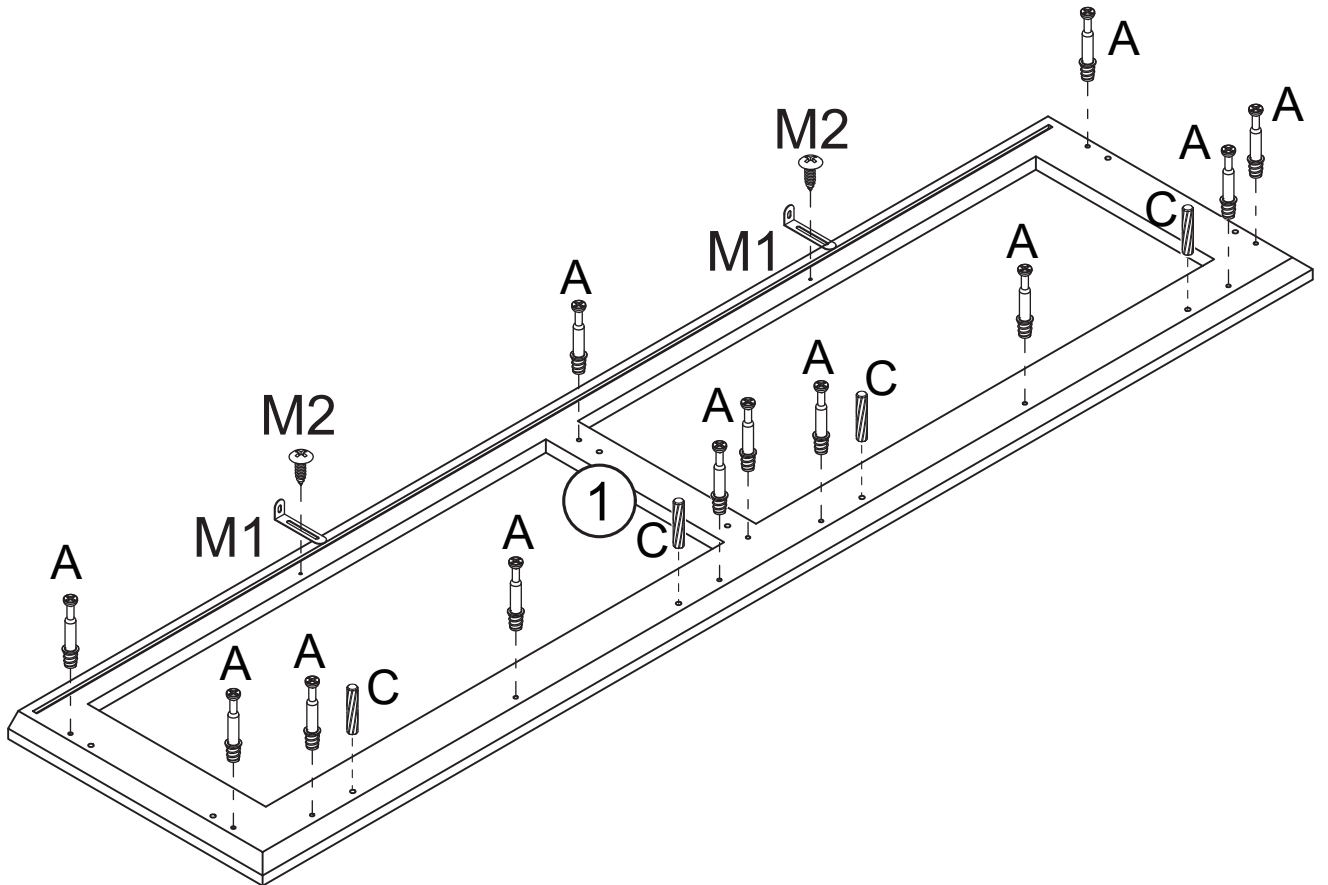

Insert (E) through (L1) and screw it into (6).

09



A x 12	C x 4	M x 2
		 
	Ø6x30mm	M1 Ø8xØ4x12mm

Insert (M2) through (M1) and screw into (1).
Screw (A) and insert (C) into the holes on (1).

10

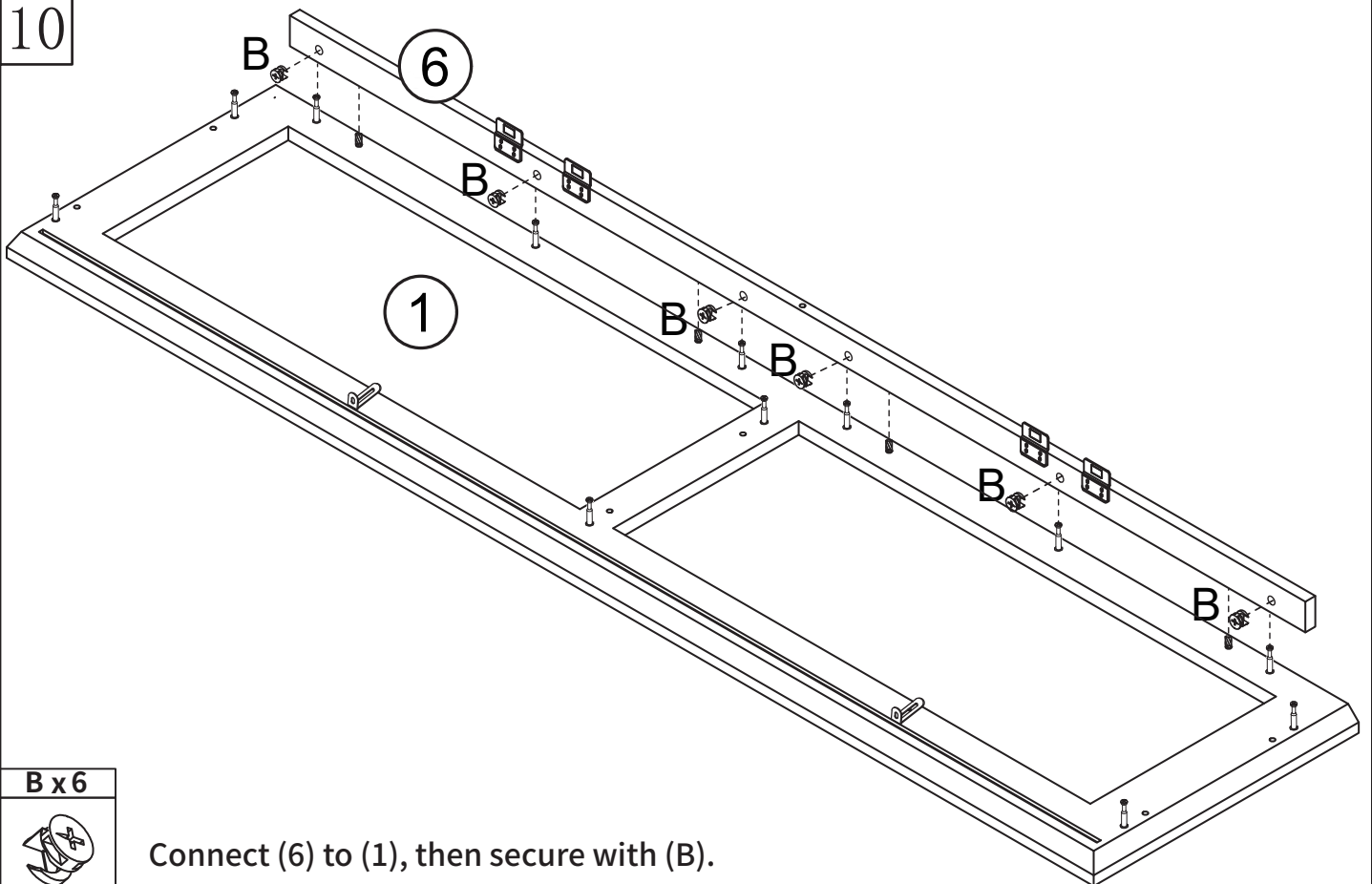

B x 6



Connect (6) to (1), then secure with (B).

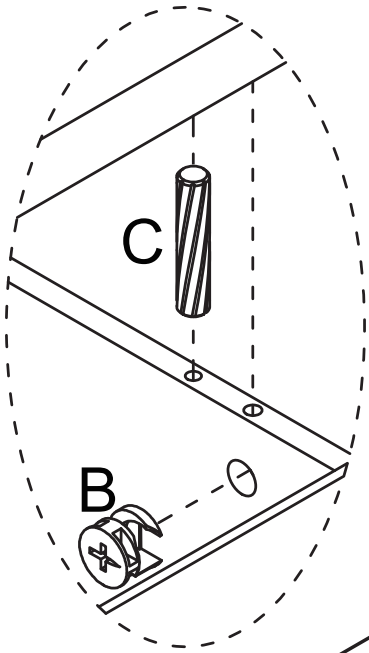

11

The thin plate needs to be fully inserted into the groove. If the insertion is not smooth, you can try pressing from the front or the back to make adjustments until the thin plate is fully inserted into the groove.

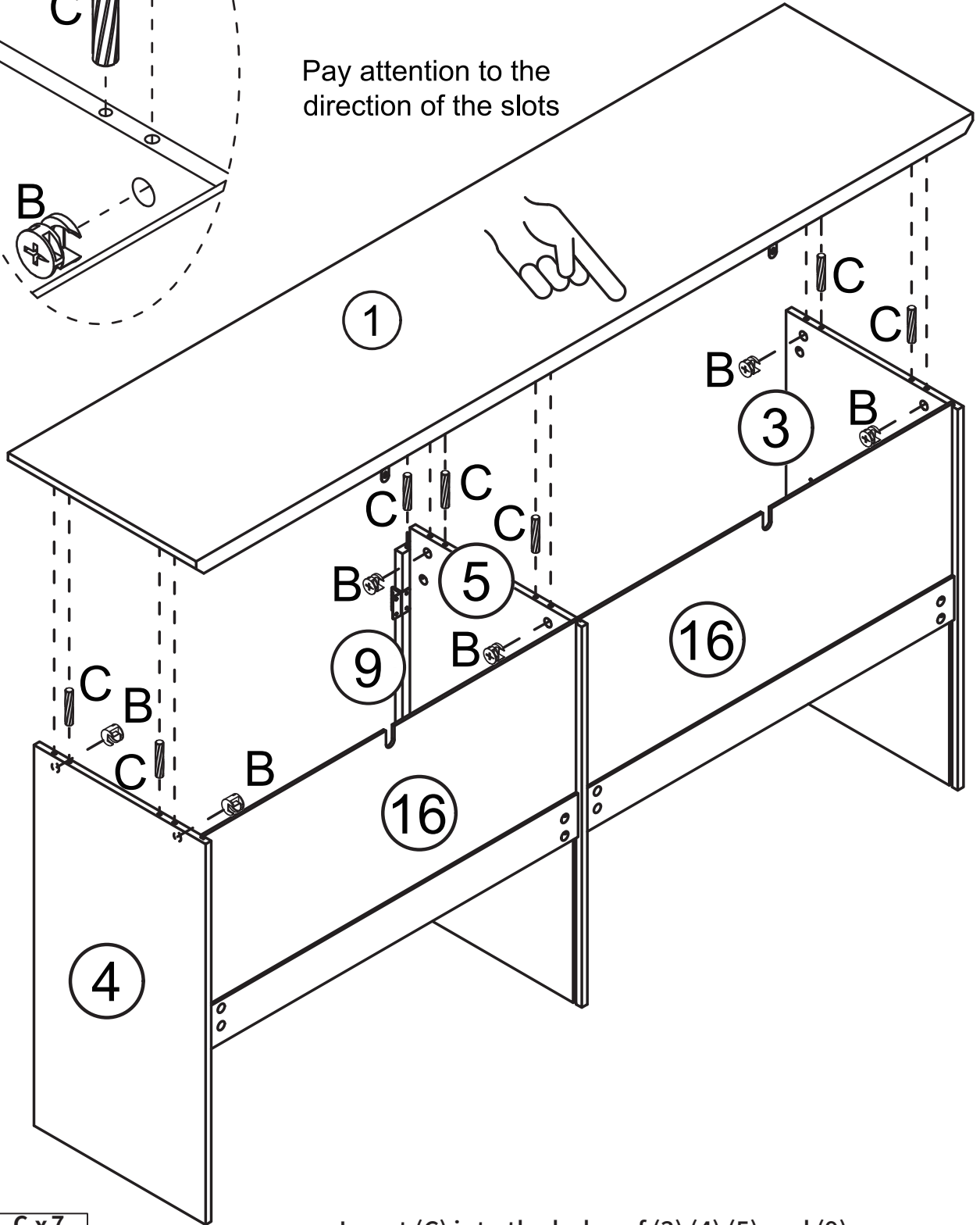

Pay attention to the direction of the slots





B x 6	C x 7
	
	Ø6x30mm

Insert (C) into the holes of (3) (4) (5) and (9).
 Connect (1) to (3) (4) and (5), then secure with (B).
 Note: (16) must fit into the groove of (1).

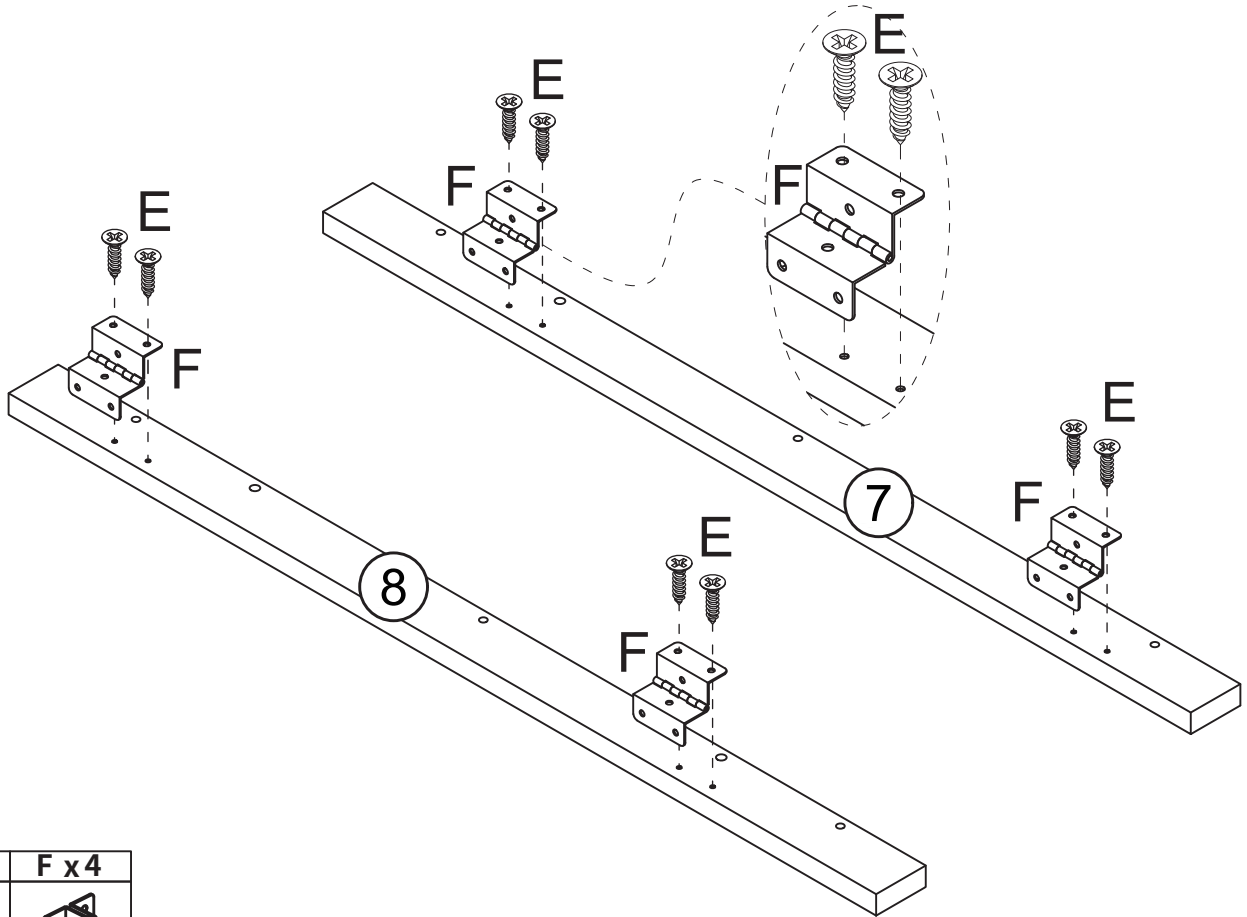
12



E x 8	F x 4
	
<small>Ø6xØ3x12mm</small>	

Insert (E) through (F) and screw it into (7) and (8).

13

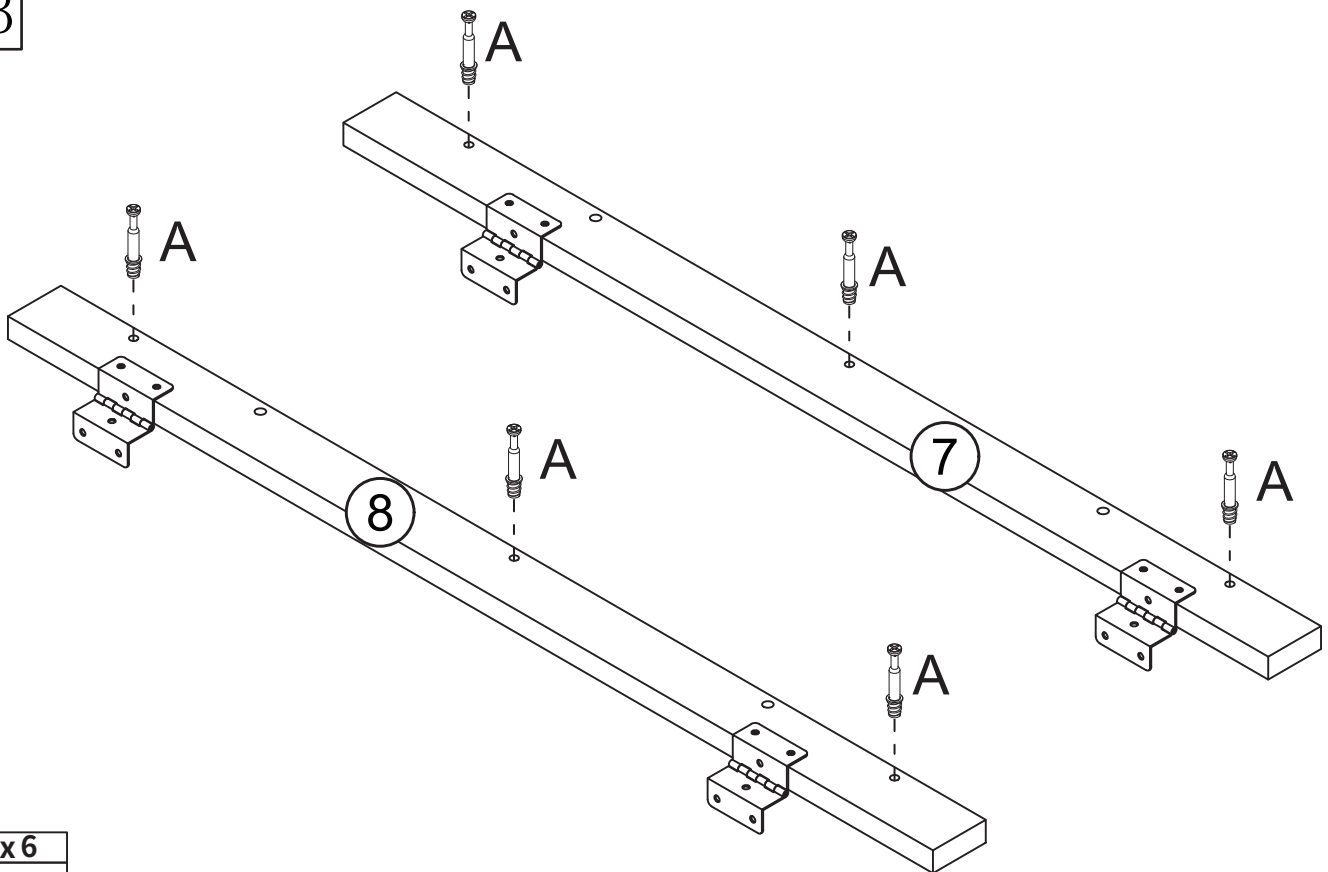



A x 6

Flip (7) and (8), then screw (A) into the holes on each.

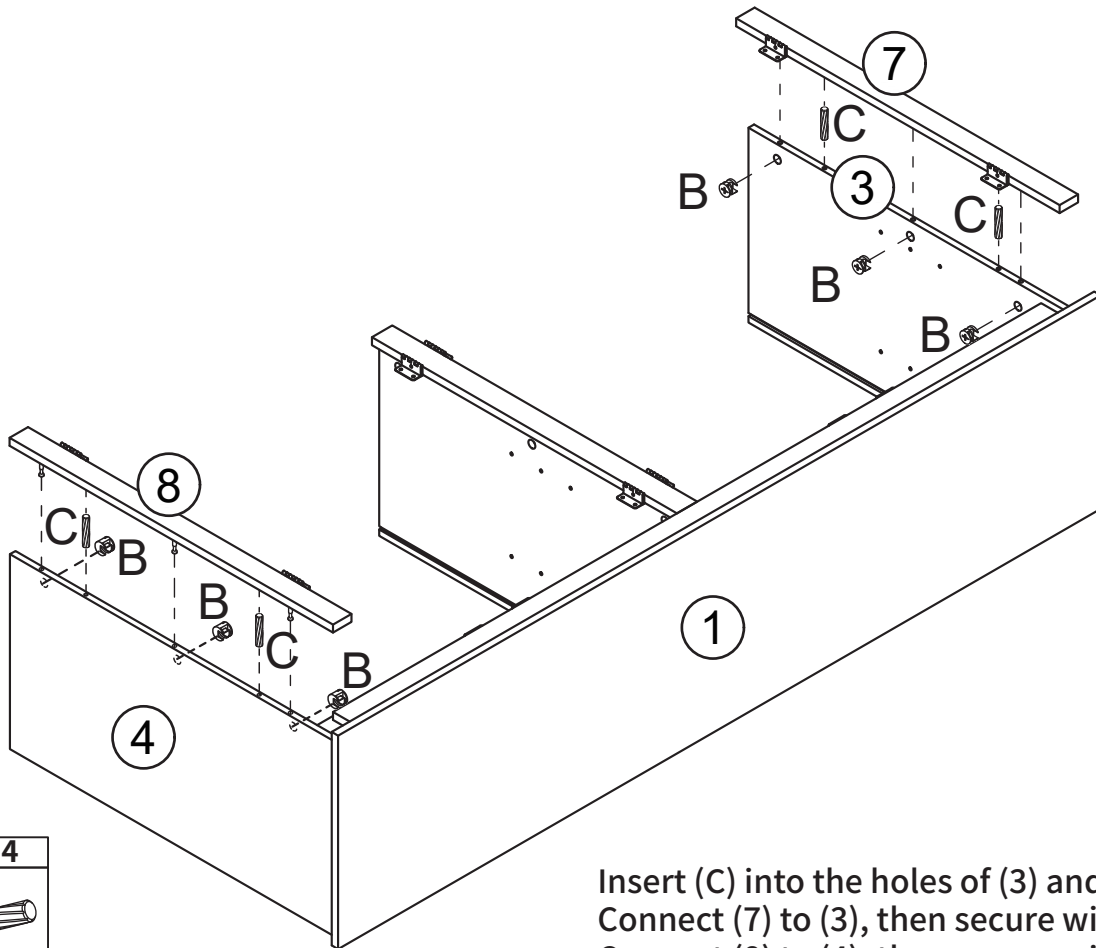
14



Insert (C) into the holes of (3) and (4).
 Connect (7) to (3), then secure with (B).
 Connect (8) to (4), then secure with (B).

B x 6	C x 4
	
	Ø6x30mm

15

The thin plate needs to be fully inserted into the groove. If the insertion is not smooth, you can try pressing from the front or the back to make adjustments until the thin plate is fully inserted into the groove.

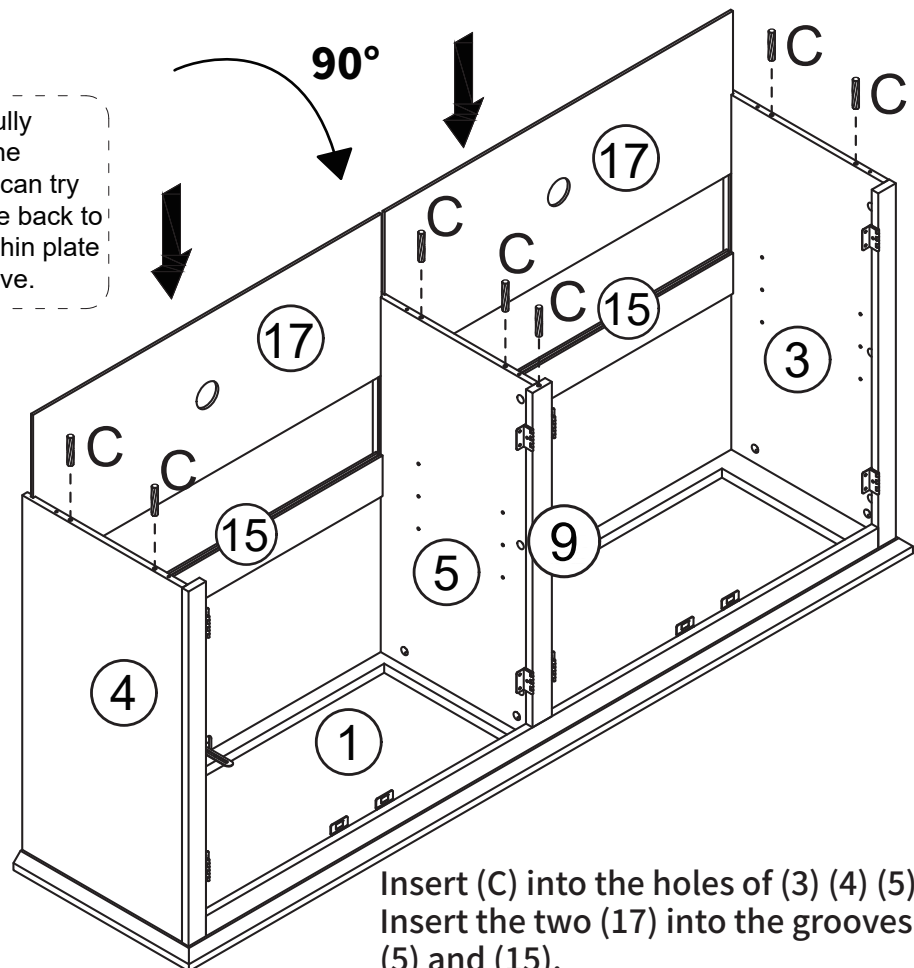

Insert (C) into the holes of (3) (4) (5) and (9).
 Insert the two (17) into the grooves of (3) (4) (5) and (15).

C x 7

Ø6x30mm

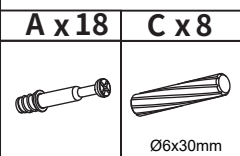
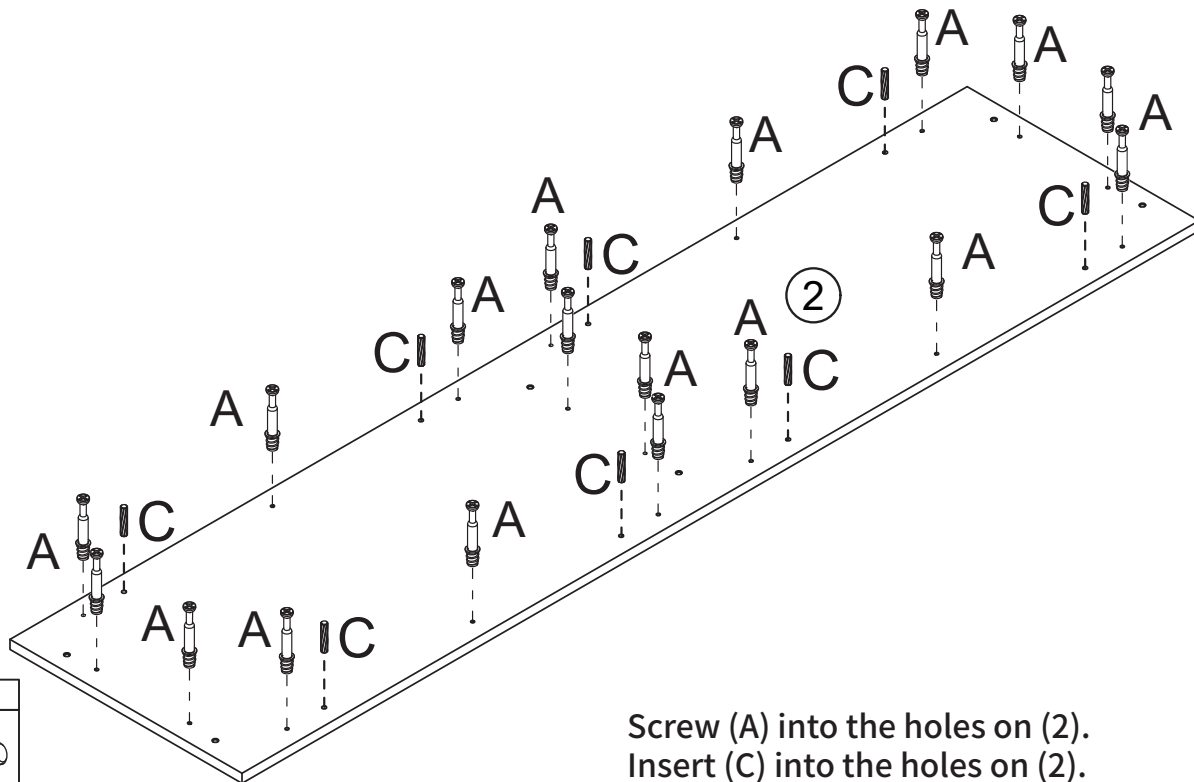
16



Screw (A) into the holes on (2).
Insert (C) into the holes on (2).

17

The thin plate needs to be fully inserted into the groove. If the insertion is not smooth, you can try pressing from the front or the back to make adjustments until the thin plate is fully inserted into the groove.

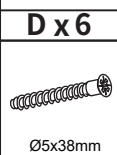
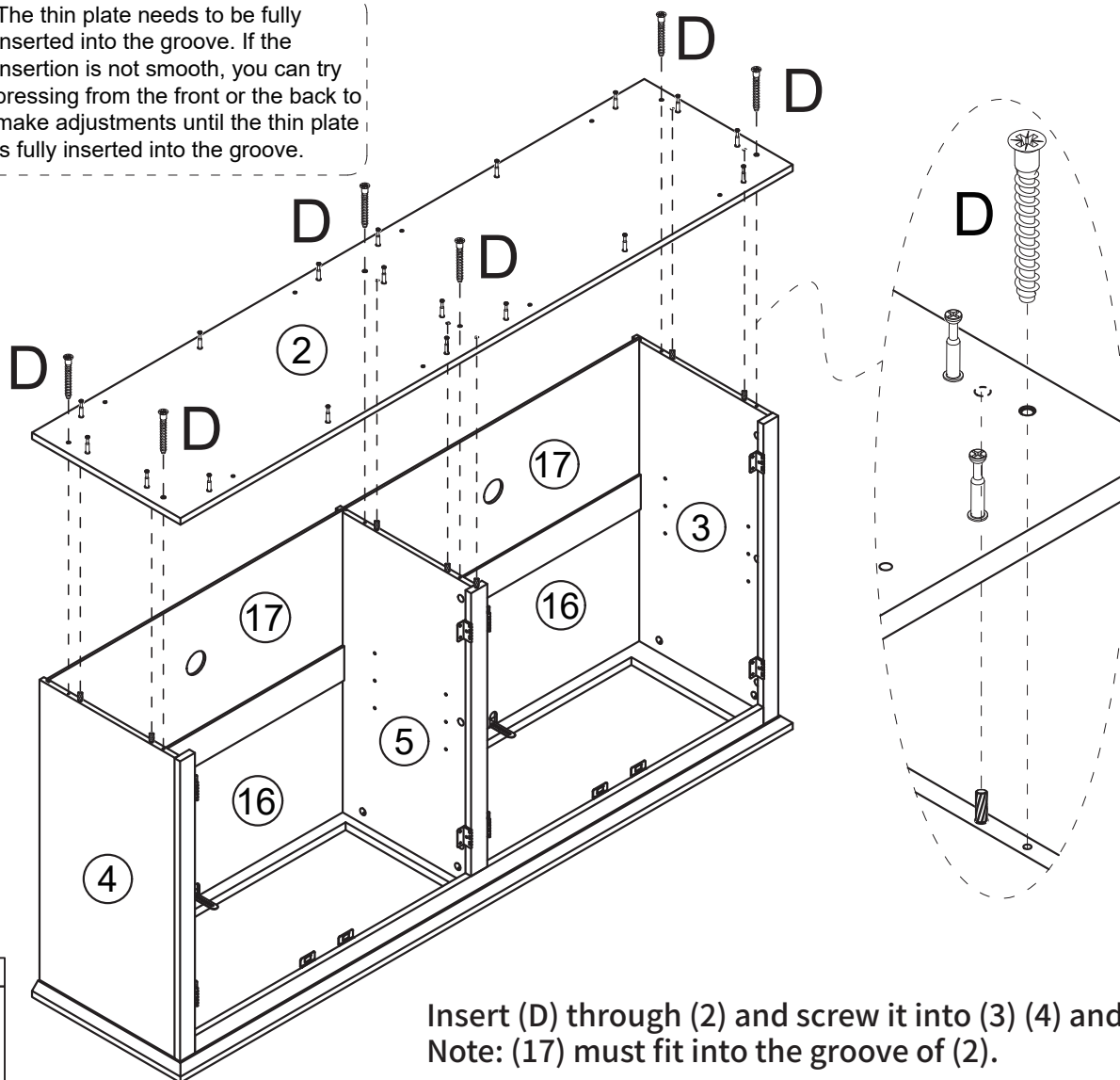

Insert (D) through (2) and screw it into (3) (4) and (5).
Note: (17) must fit into the groove of (2).

18

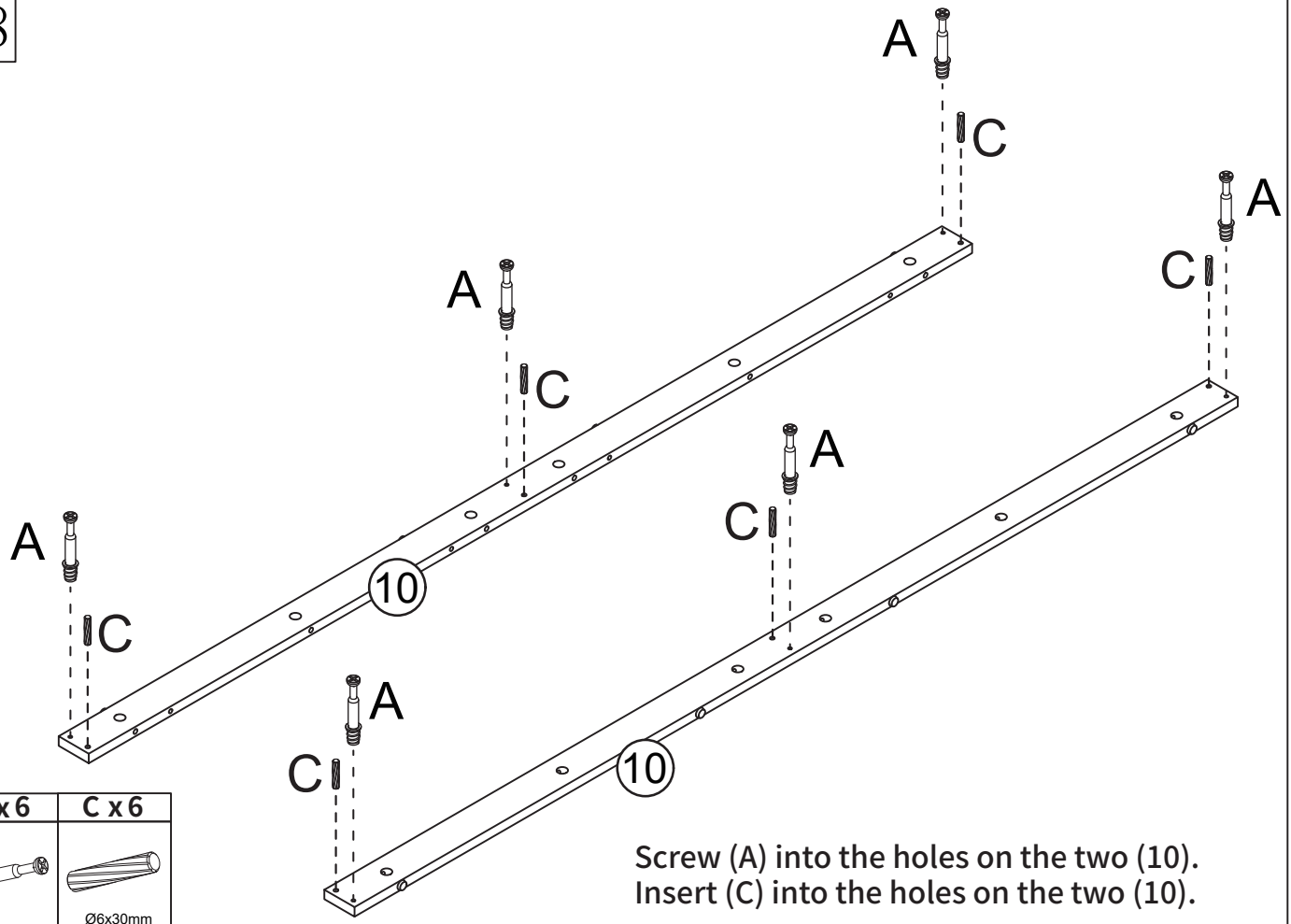

19

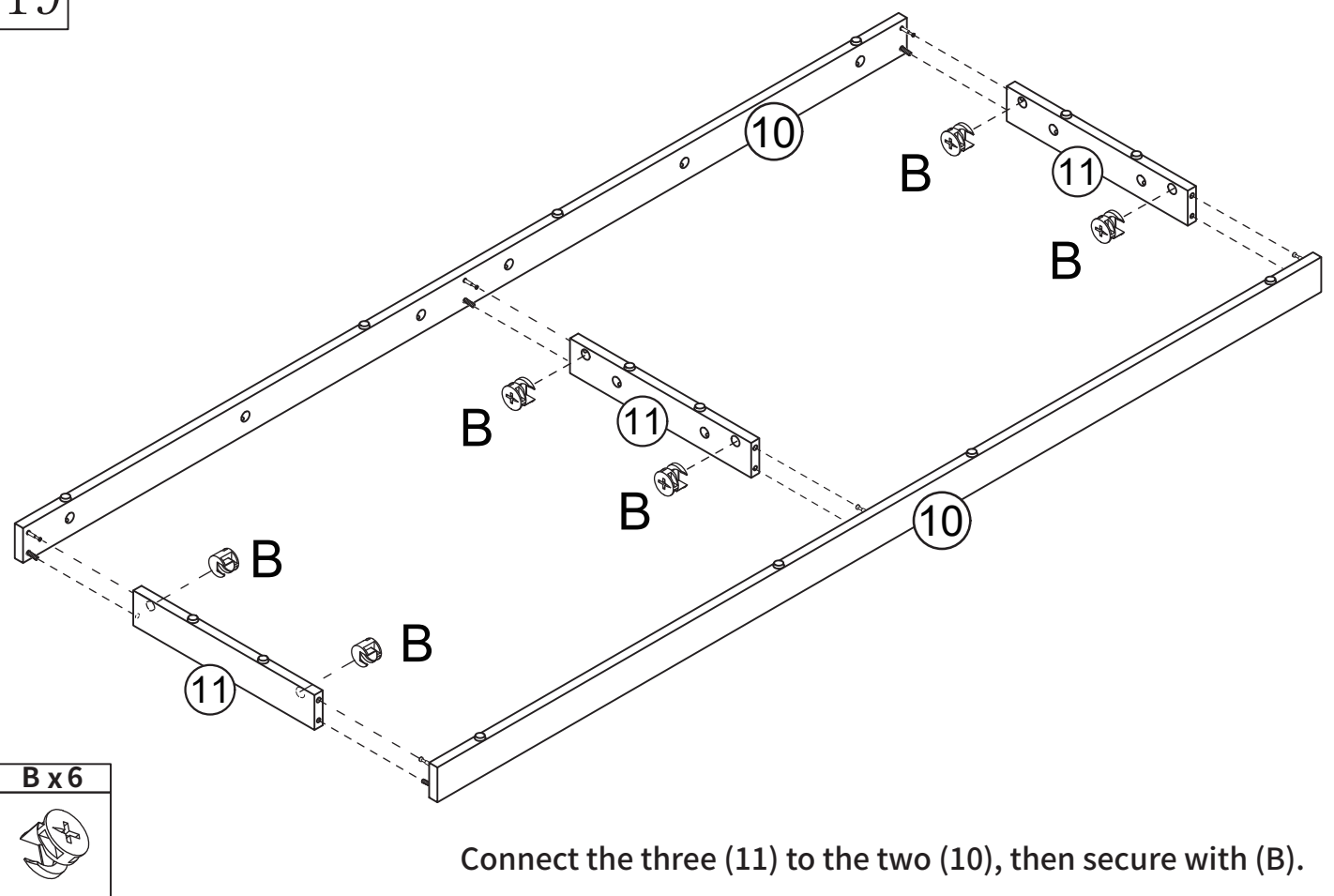

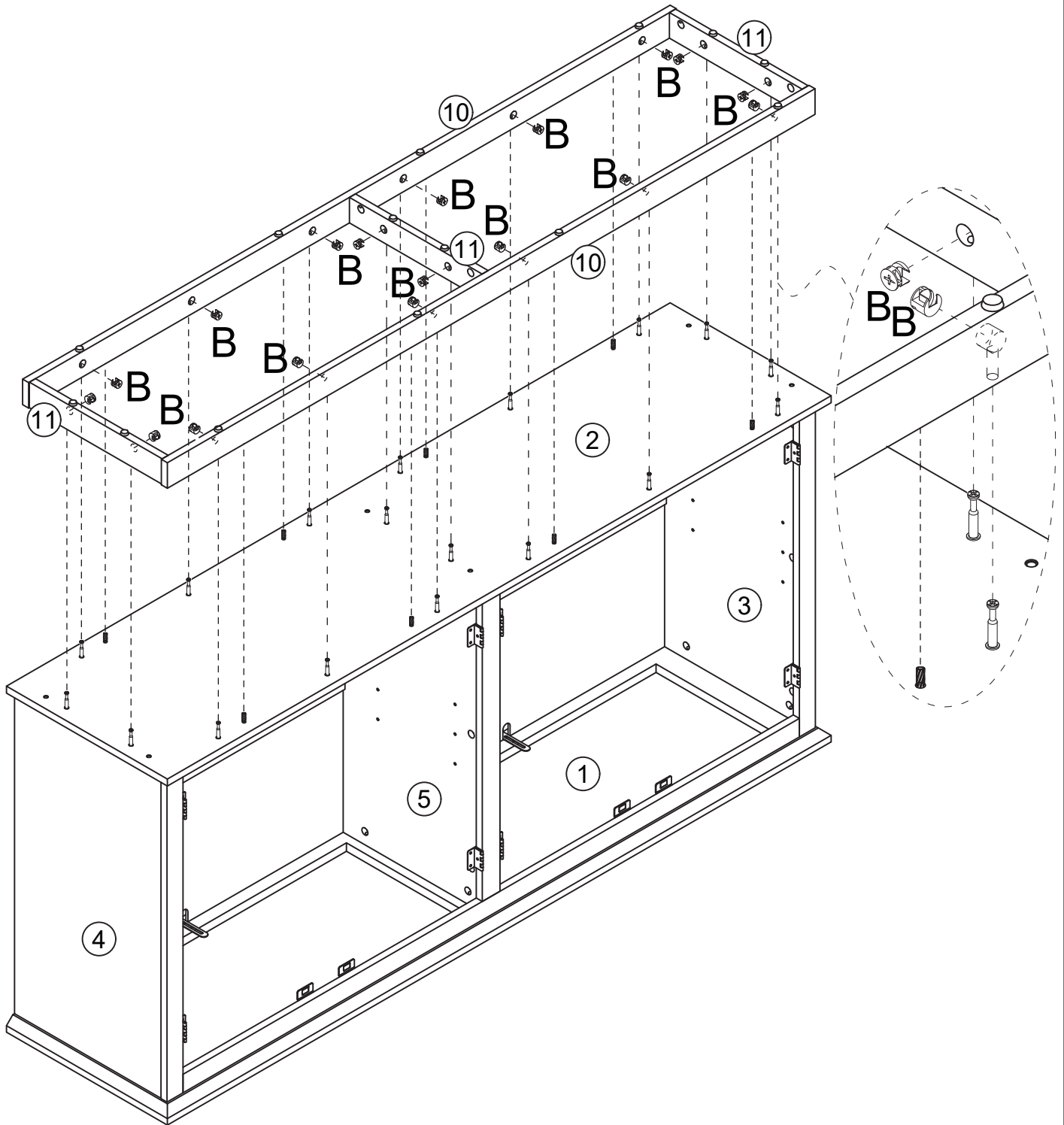

B x 18

Connect (2) to the frame formed by (10) and (11), then secure with (B).

21

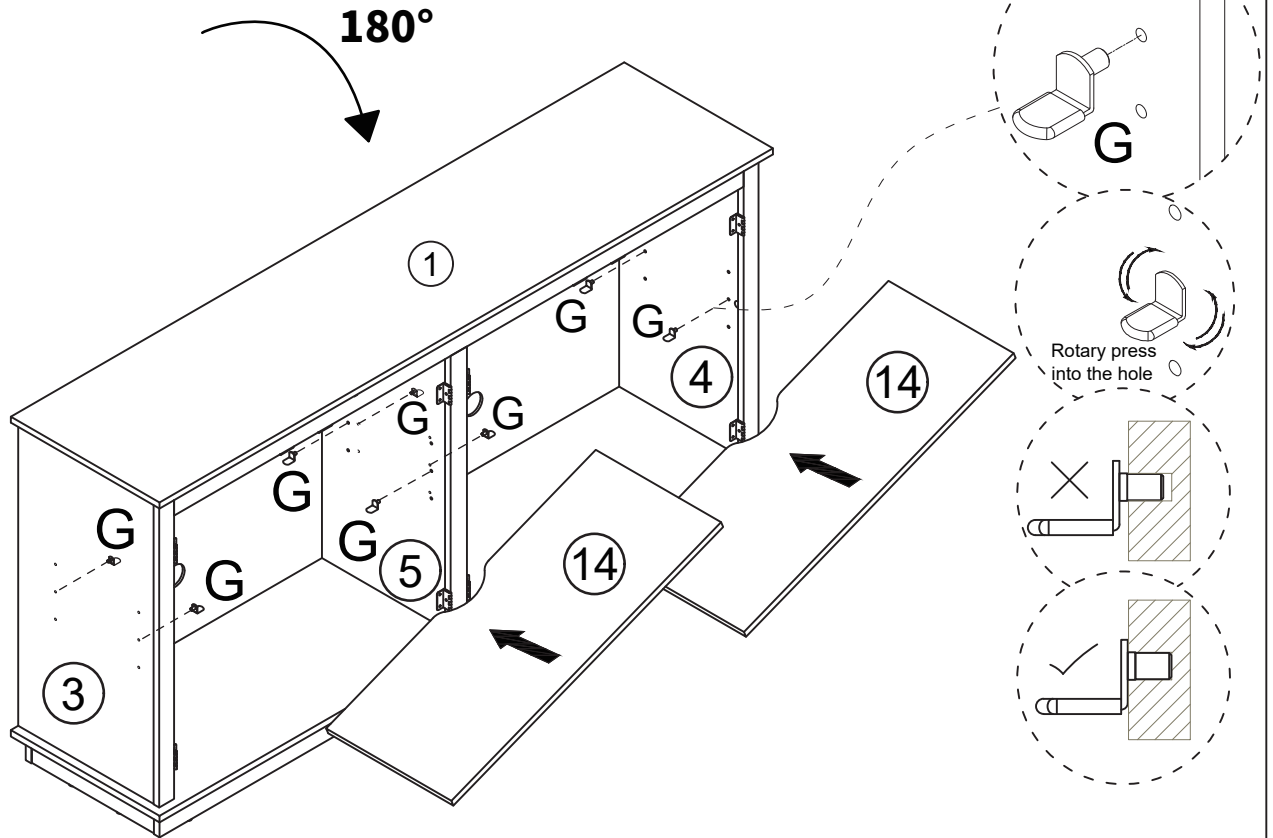

G x 8



Insert (G) into the holes of (3) (4) and (5), then place (14) on top of (G).

22

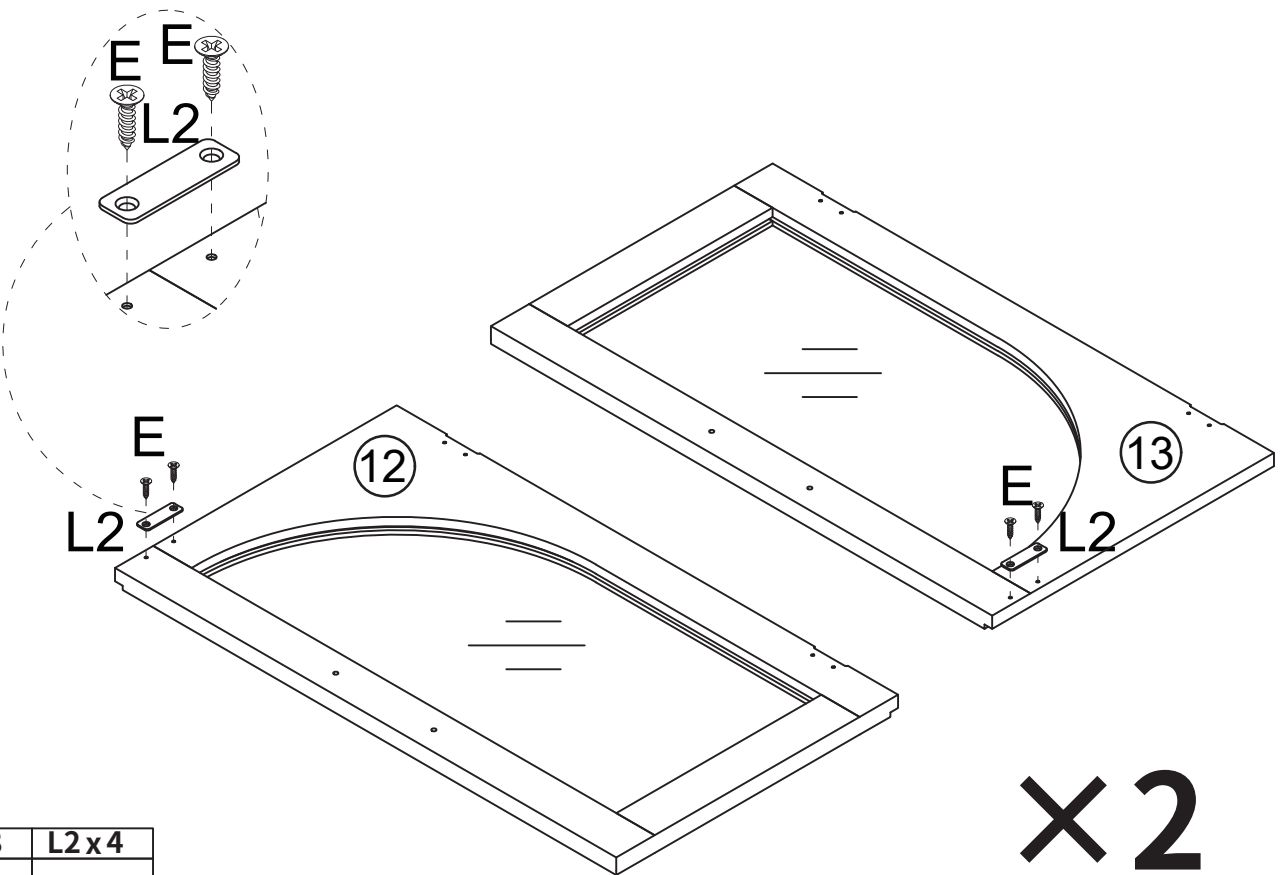

E x 8

L2 x 4



Ø6xØ3x12mm



Insert (E) through (L2) and screw it into (12) and (13).

x2

23

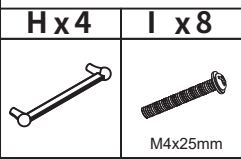
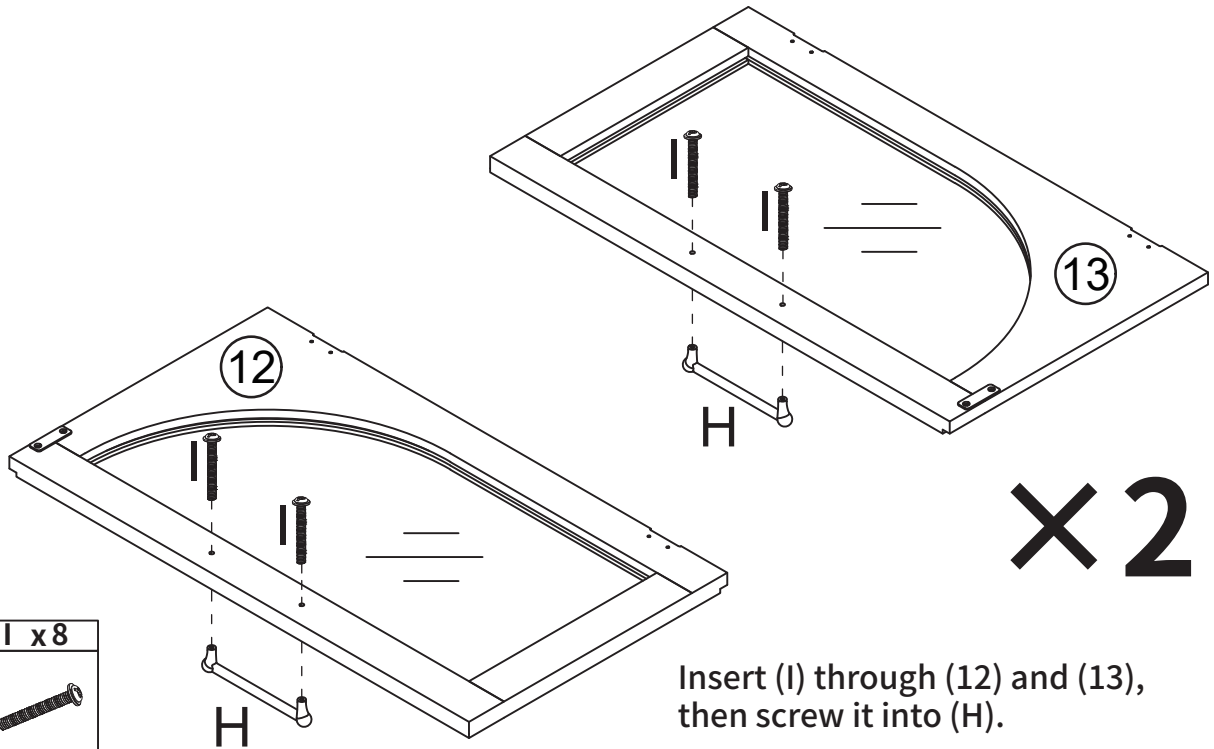

Insert (I) through (12) and (13), then screw it into (H).

24

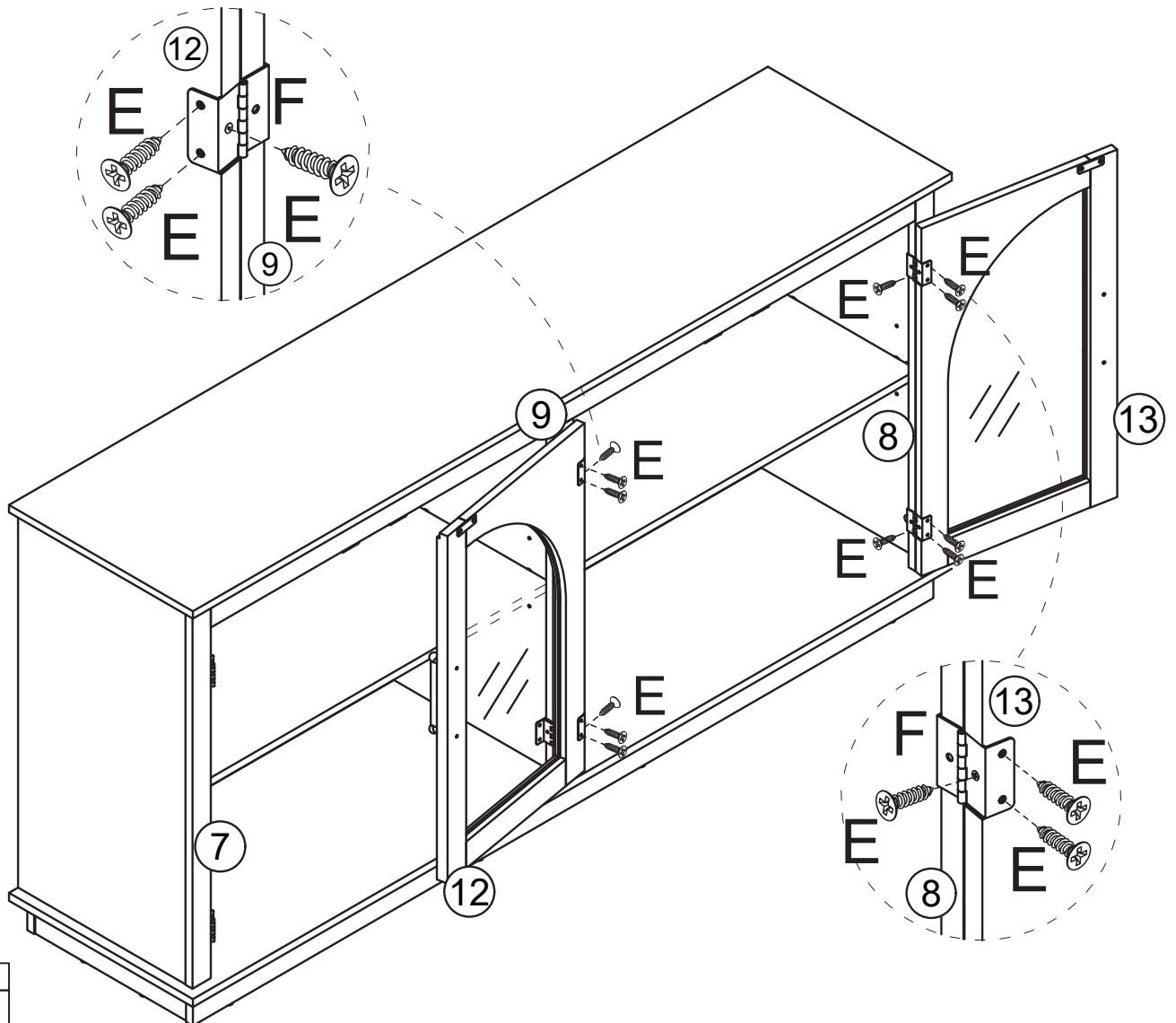

As shown, insert (E) through (F) into (8) and (9), then screw into (12) and (13).

25

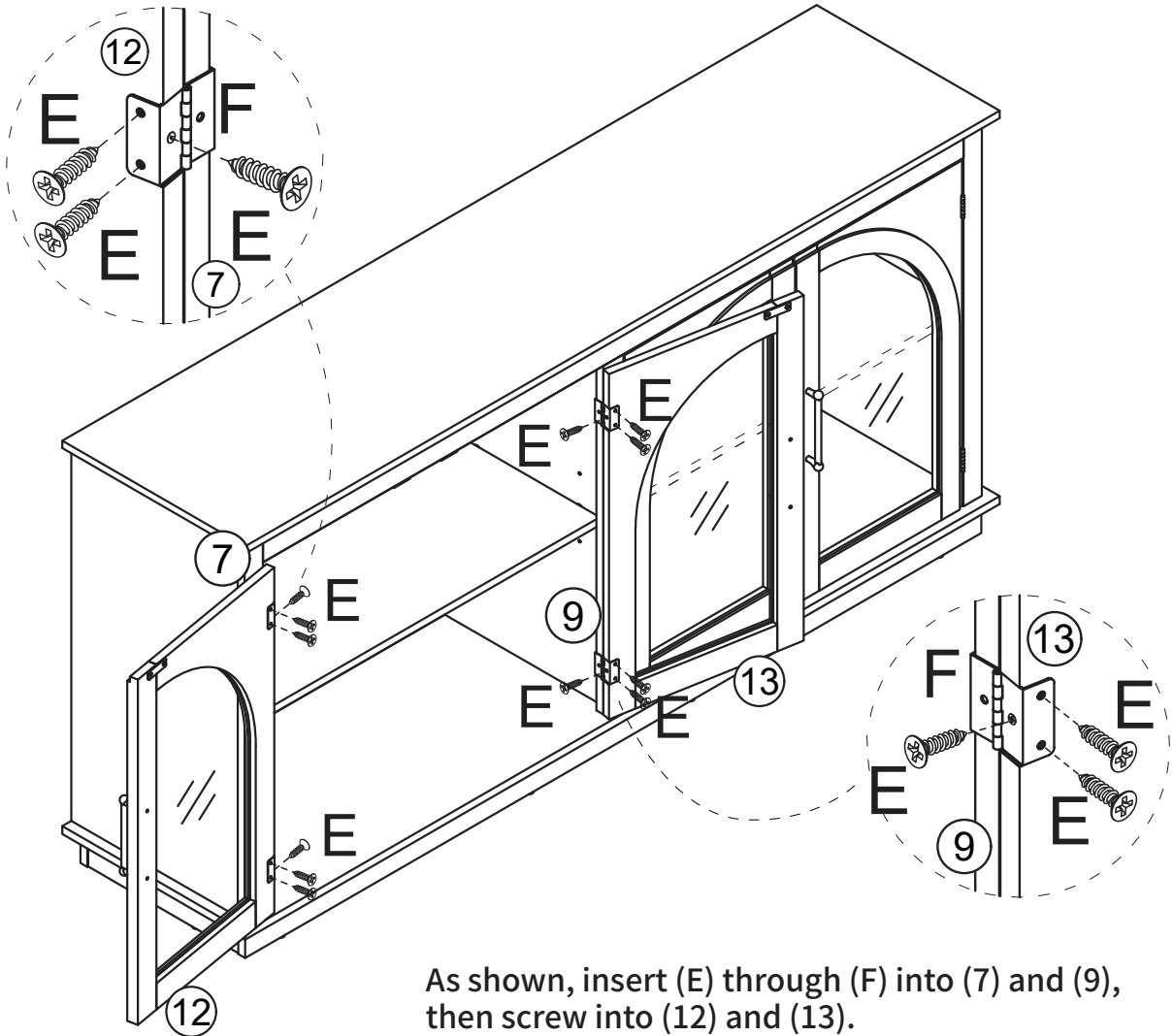

As shown, insert (E) through (F) into (7) and (9), then screw into (12) and (13).

26

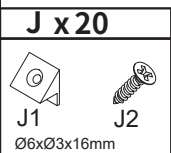
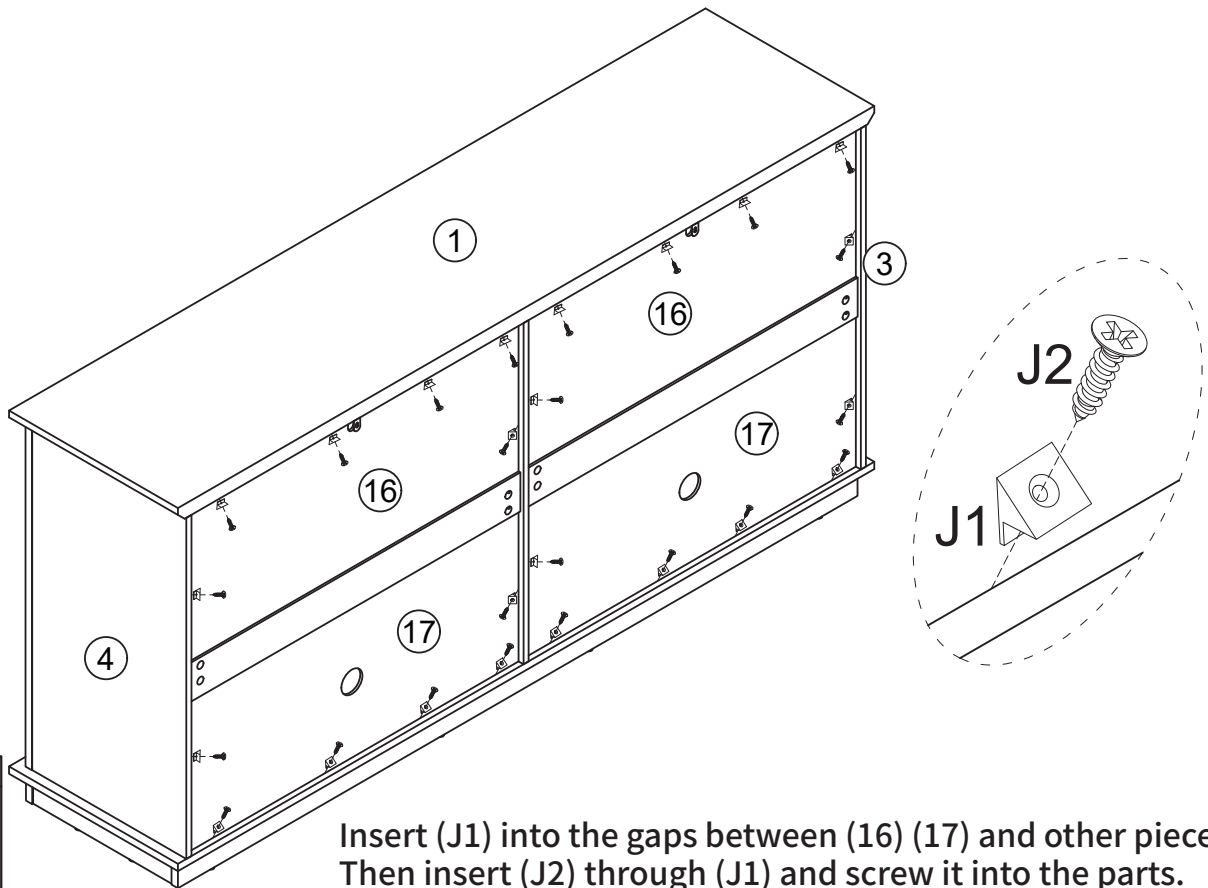

Insert (J1) into the gaps between (16) (17) and other pieces. Then insert (J2) through (J1) and screw it into the parts.

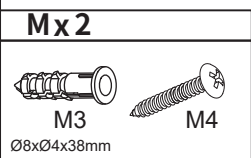
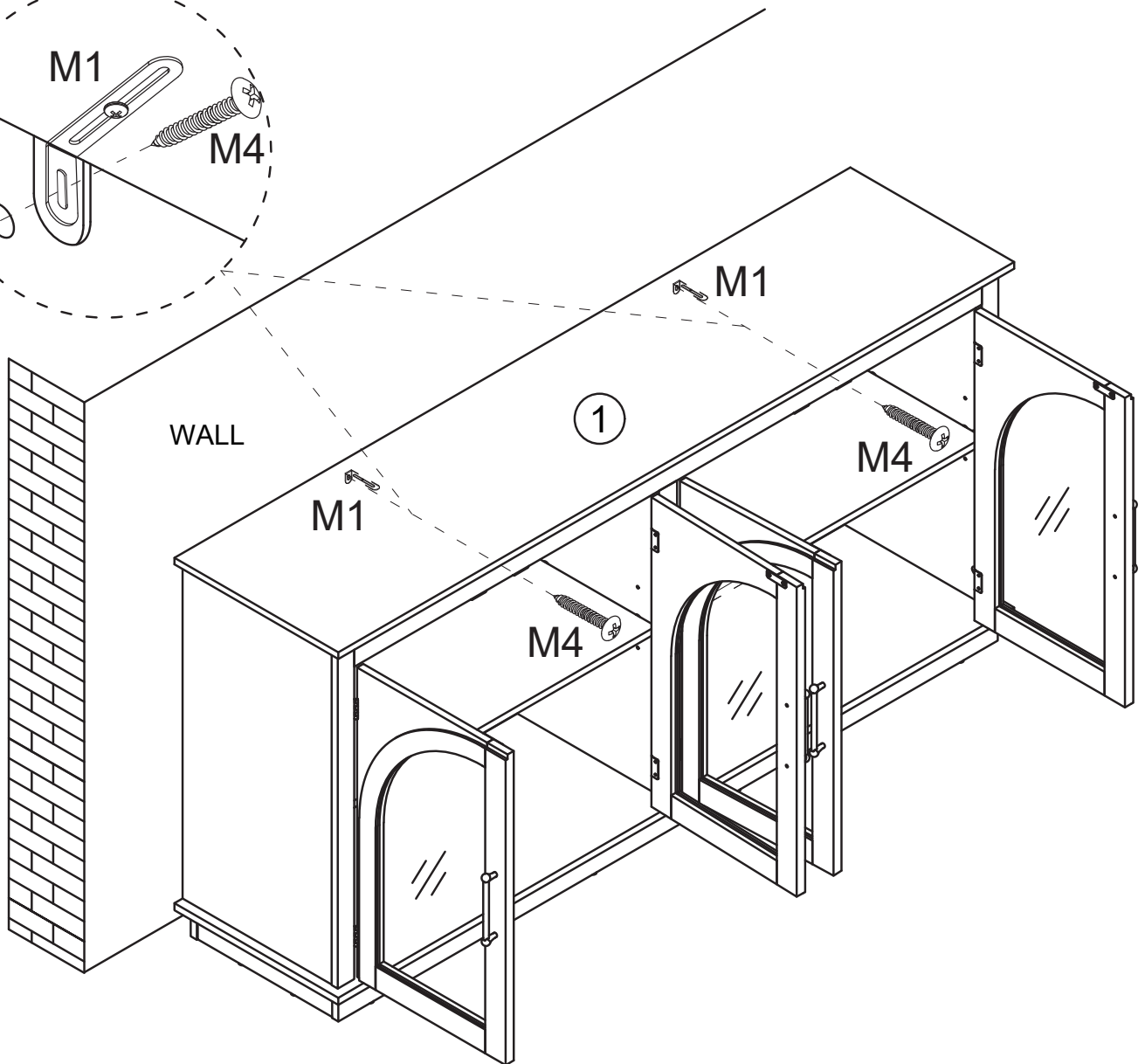
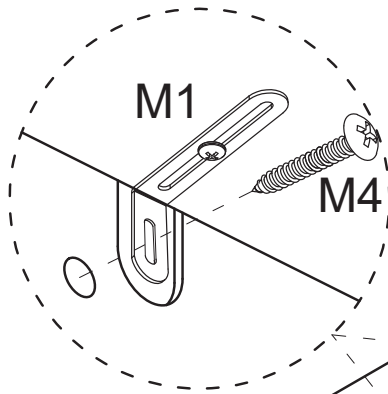
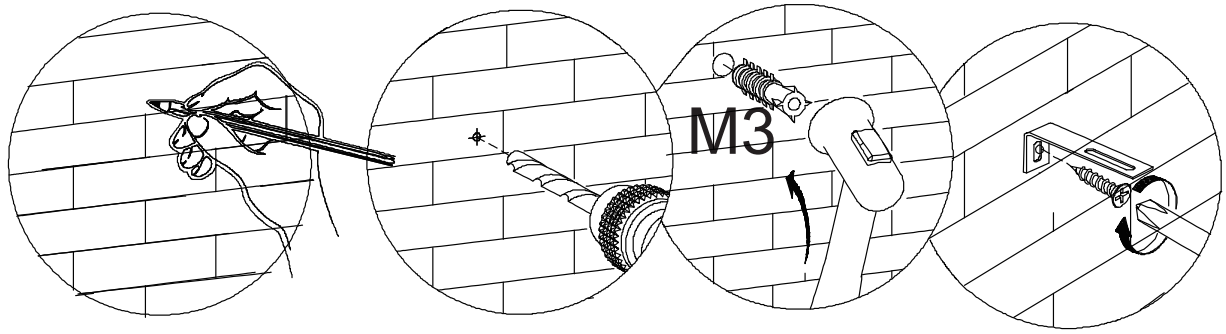

Mark the drilling position on the wall, drill a hole, and insert (M3). Insert (M4) through (M1) fixed on (1), then screw it into (M3).

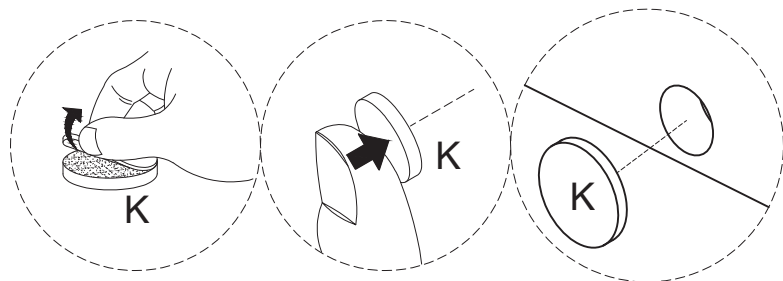
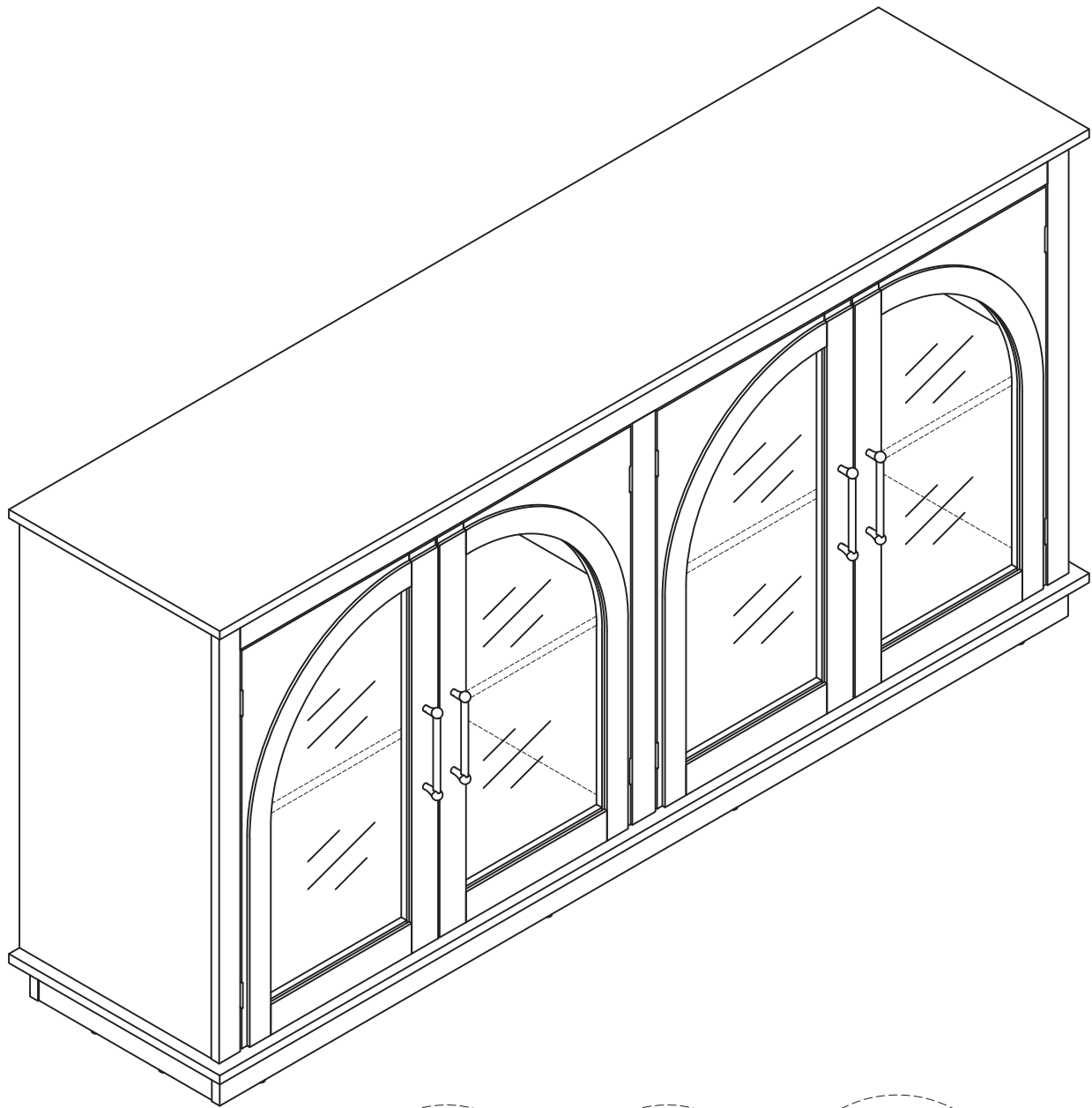

Done!

Exposed holes can be attached with ickers **K**

K x24



Ø20mm