

**COGNAC CHERRY** : CERISIER COGNAC : *CEREZO COÑAC*

**BORDEAUX & GRAPHITE** : BORDEAUX ET GRAPHITE : *BURDEOS Y GRAFITO*

**CHOCOLATE** : CHOCOLAT : *CHOCOLATE*

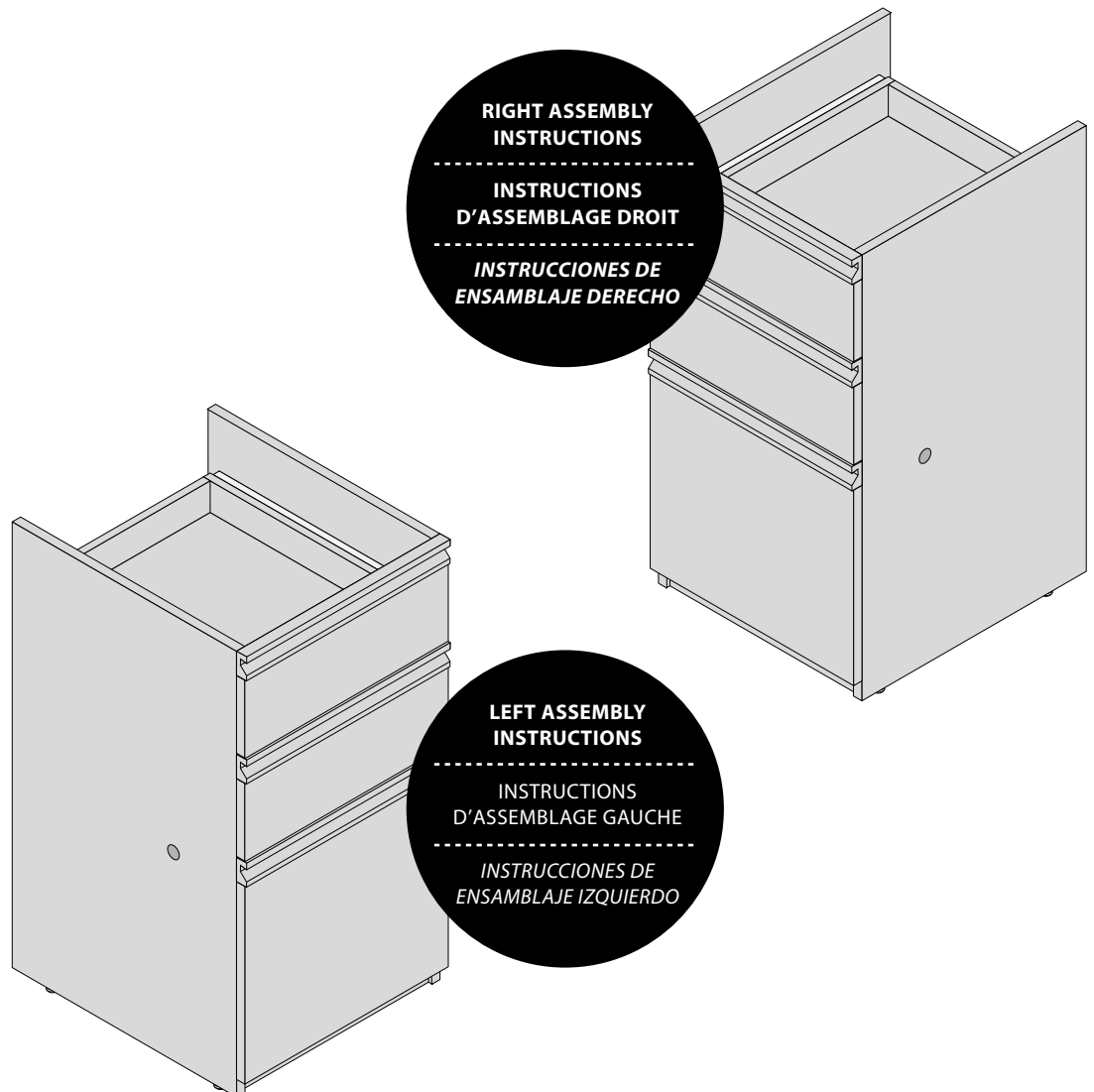

**Thank you for choosing a product. Your total satisfaction is our #1 priority.**

Customer service and warranty information



**Merci d'avoir choisi les produits. Vous satisfaire est notre priorité.**

Service à la clientèle et informations relatives à la garantie











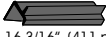

**Gracias por elegir un producto.  
Su entera satisfacción es nuestra prioridad N°1.**

Servicio de atención al cliente e información sobre la garantía

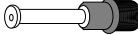

► PARTS / PIÈCES / PIEZAS

CODE / CÓDIGO	QTY / QTÉ / CANT.	CODE / CÓDIGO	QTY / QTÉ / CANT.	CODE / CÓDIGO	QTY / QTÉ / CANT.	CODE / CÓDIGO	QTY / QTÉ / CANT.
CA01A	4	CA13A	2	66	2	81	1
CA05A	4	17	1	67	1	<b>bottom / fond / fondo</b> 15 3/8" x 12 7/16" (391 mm x 316 mm)	3
CA09A	2	18	1	CA70B	1	<b>moldings / moulures / molduras</b> 1 9/16" x 15 3/8" (40 mm x 390 mm)	3

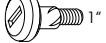
► HARDWARES / QUINCAILLERIES / QUINCALLAS

CODE / CÓDIGO	QTY / QTÉ / CANT.	CODE / CÓDIGO	QTY / QTÉ / CANT.	CODE / CÓDIGO	QTY / QTÉ / CANT.	CODE / CÓDIGO	QTY / QTÉ / CANT.
CL-745 	1	EX-702  16 3/16" (411 mm)	2	SE-686 	1	VR-207  1/2" (13 mm)	24
CO-249 <b>runners 406 mm (16")</b> coulisseaux 406 mm corredoras 406 mm	3	H-03 	18	VE-244  3/8" (10 mm)	18	VR-212  1" (25 mm)	25
CR-141 	2	H-04 	10	VM-601  3/4" (20 mm)	6		
EC-744 	6	H-36 	8				
EX-681  13 1/8" (303 mm)	2	PA-844  1" (25 mm)	4				

► REAL SIZE / GRANDEUR RÉELLE / TAMAÑO REAL

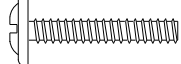
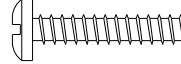
CODE / CÓDIGO	QTY / QTÉ / CANT.	CODE / CÓDIGO	QTY / QTÉ / CANT.
VE-244  3/8" (10 mm)	18	VR-207  1/2" (13 mm)	24
VM-601  3/4" (20 mm)	6	VR-212  1" (25 mm)	25

 **two people are required to assemble and move this model.**  
deux personnes sont requises pour assembler et déplacer ce modèle.  
se necesitan dos personas para ensamblar y desplazar este mueble.

 **the use of electric tools must be made with vigilance.**  
l'utilisation d'outils électriques doit être faite avec vigilance.  
las herramientas eléctricas deben utilizarse con sumo cuidado.

**tools required**  
outils requis  
herramientas necesarias

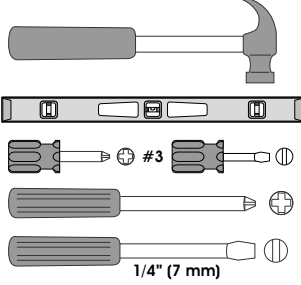
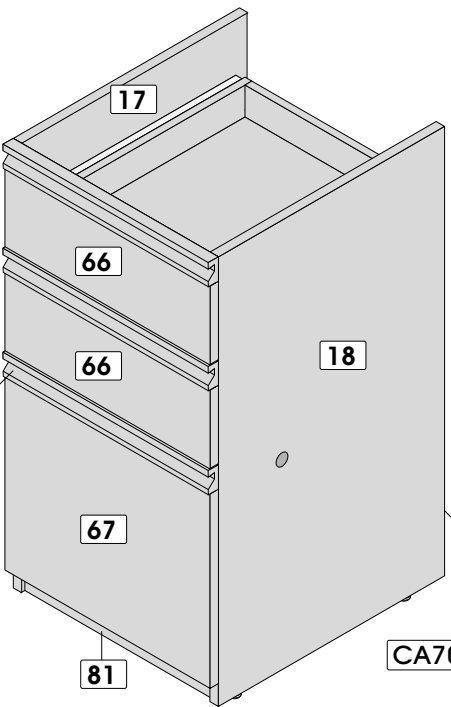
**moldings / moulures / molduras**  
1 9/16" x 15 3/8" (40 mm x 390 mm)

► IMPORTANT NOTICE / NOTE IMPORTANTE / NOTA IMPORTANTE

**Group together all the hardware required for each step as the construction of your piece of furniture is progressing.**  
Regroupez toutes les quincailleries requises pour chaque étape de façon à vous assurer de tout installer au bon moment.  
Reúna todas las quincallas necesarias para cada una de las etapas de montaje, para asegurar una correcta instalación en el momento adecuado.

# ▶ IMPORTANT NOTICE / NOTE IMPORTANTE / NOTA IMPORTANTE

Duly complete the self-adhesive sticker. / Assurez-vous de bien remplir l'auto-collant. / Asegúrese de completar correctamente la etiqueta.

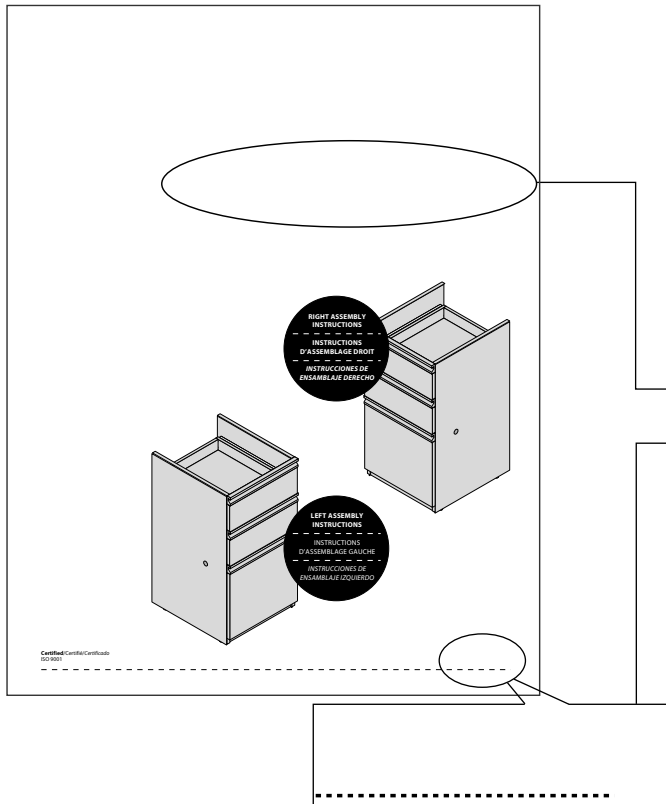

**To better serve you!**  
Pour mieux vous servir!

→ **Model / Modèle:** \_\_\_\_\_

→ **Production Number**  
Numéro de production: \_\_\_\_\_

**Customer Service**  
Service à la clientèle

## Important/Importante

**Please retain the self-adhesive sticker which you will install at step 11 of the instruction manual.**

Conservez l'autocollant qui sera collé seulement à l'étape 11 du feuillet d'instructions.

Conserve la etiqueta que será pegada sólo en la etapas 11 de la hoja de instrucciones.

# ▶ IMPORTANT NOTICE / NOTE IMPORTANTE / NOTA IMPORTANTE

▶ **Main hardware system / Système de quincaillerie principal / Sistema principal de quincailla**

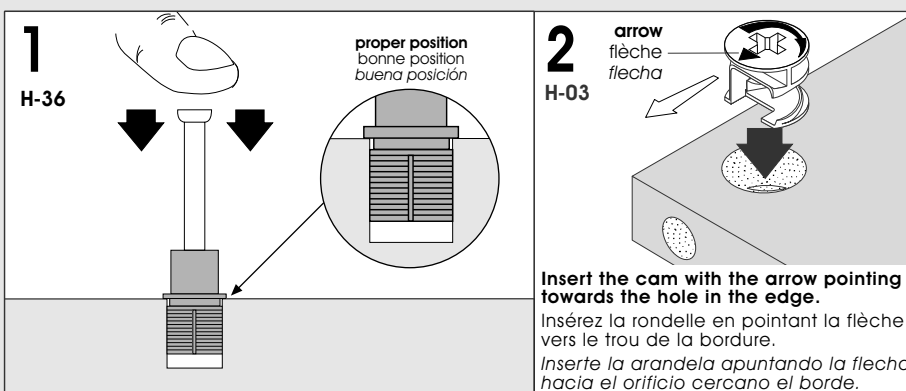

**If needed / En cas de nécessité**  
En caso de necesidad

**How to remove a misplaced assembly bolt (H-36).**  
Comment retirer un boulon (H-36) mal situé.  
Cómo retirar un perno (H-36) mal ubicado.

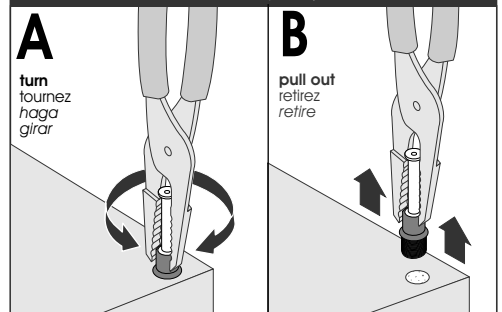

**Pedestal with 3 Drawers / Caisson à trois tiroirs / Modulo con tres cajones**

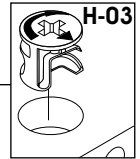
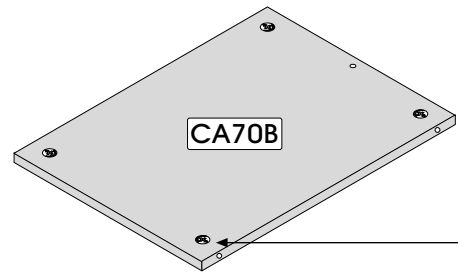

**important / importante**

**VR-207** Install the locking device on panel 18 for left assemblage.  
 Installez la barrure sur le côté 18 pour l'assemblage gauche.  
 Instale la barra sobre la pieza 18 para la ensablaje izquierdo

**SE-686**

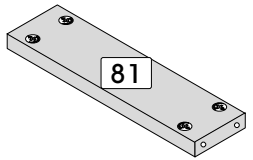
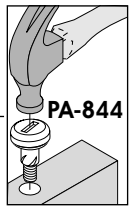
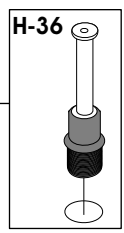
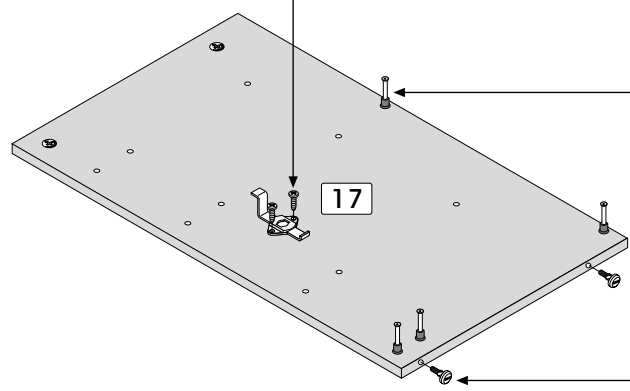
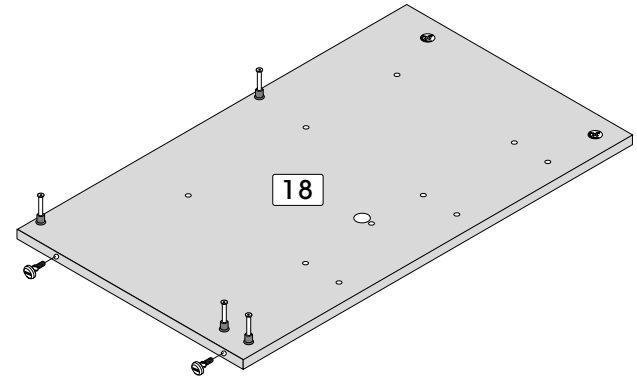

Code / Código	TI-552	H-03	H-36	PA-844 1" (25 mm)	SE-686	VR-207 1/2" (13 mm)
Qty / Qté / Cant.	x 2	x 12	x 8	x 4	x 1	x 2

**2** **HARDWARE INSTALLATION / INSTALLATION DES QUINCAILLERIES / INSTALACIÓN DE LAS QUINCALLAS**

**Pedestal with 3 Drawers / Caisson à trois tiroirs / Modulo con tres cajones**

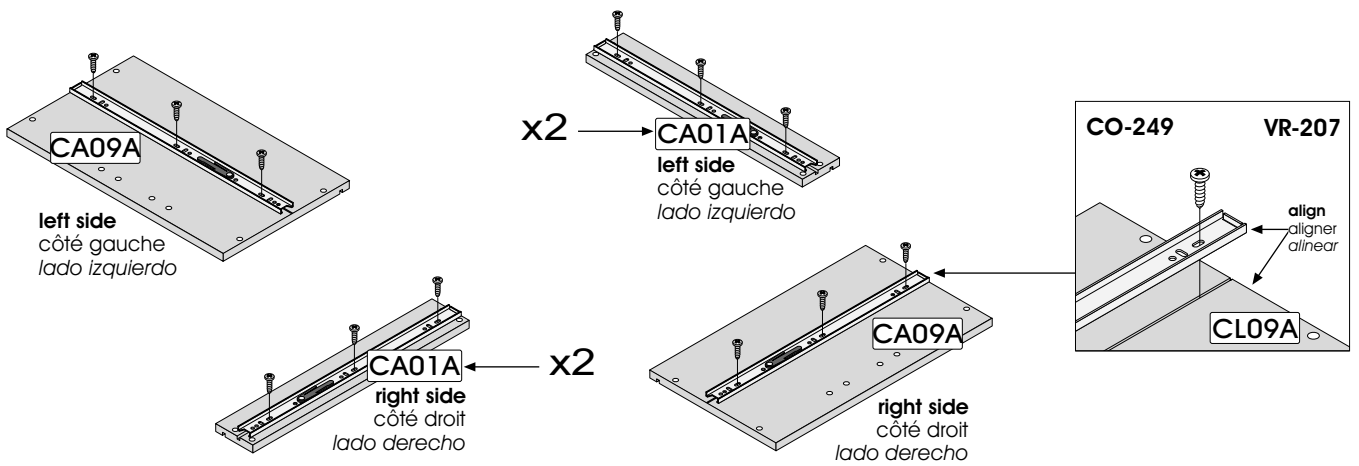
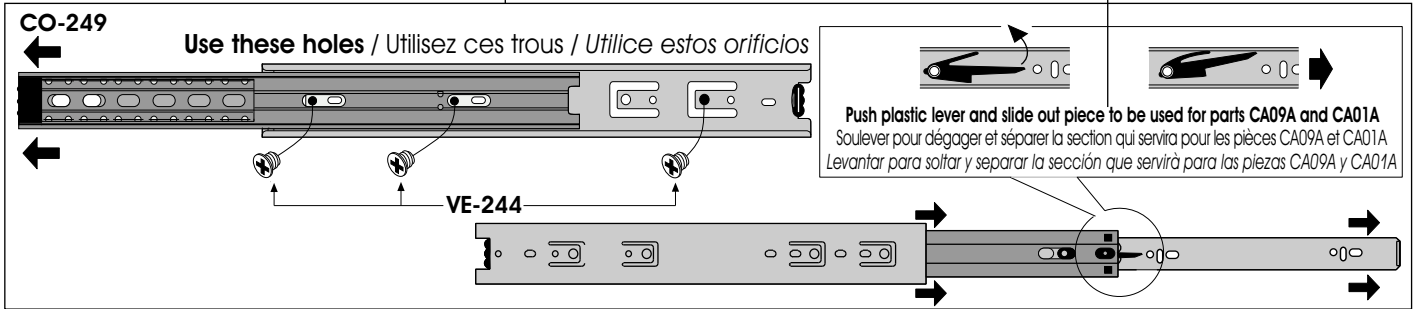
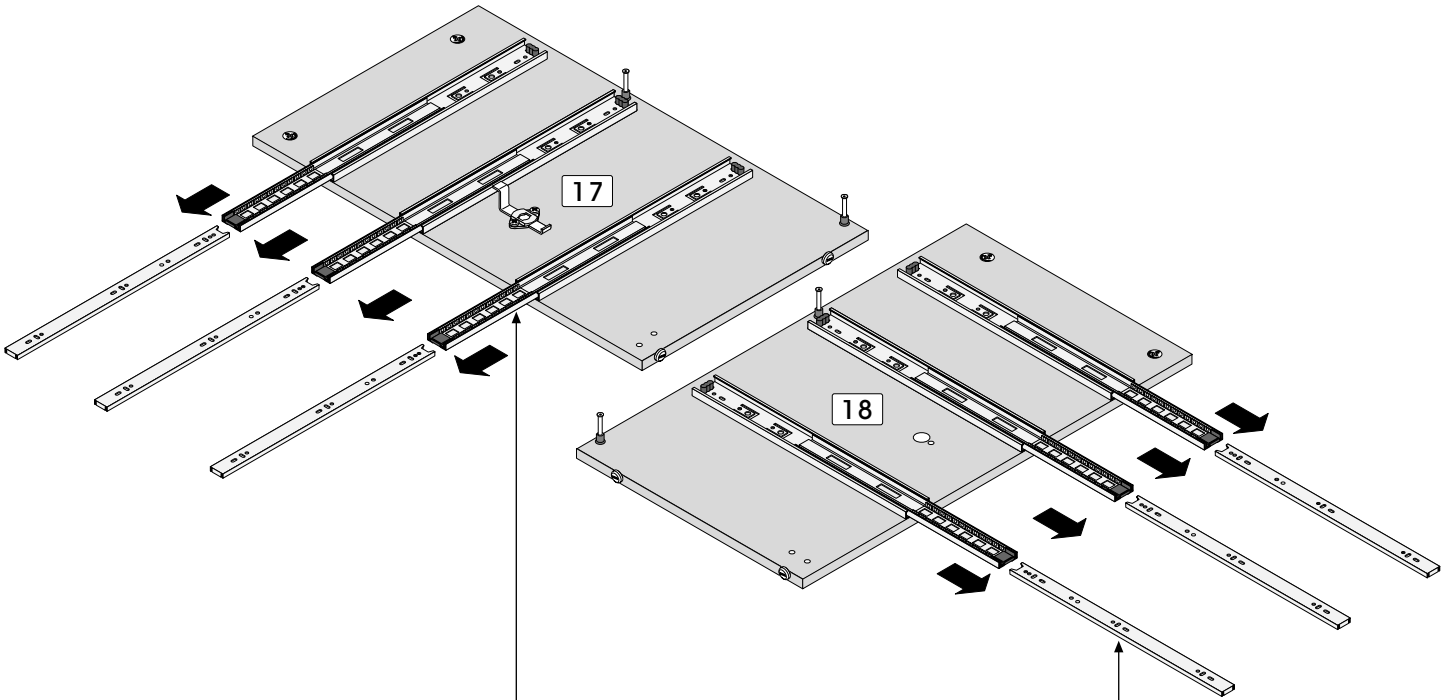

**2**

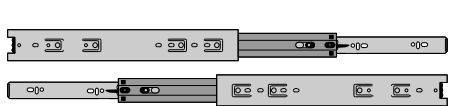

Code / Código

CO-249

VR-207

VE-244

Qty / Qté / Cant.

x 3

x 18

x 18

## IMPORTANT NOTICE / NOTE IMPORTANTE / NOTA IMPORTANTE

### Main hardware system / Système de quincaillerie principal / Sistema principal de quincalla

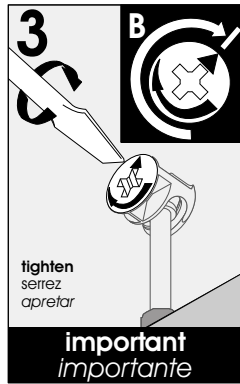
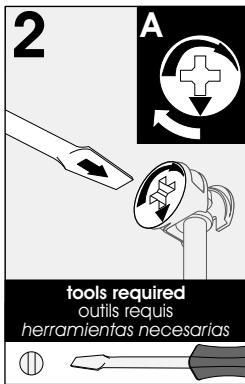
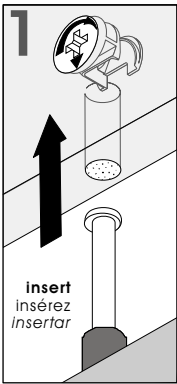

Make sure to properly tighten each cam to ensure furniture solidity. Otherwise, parts could be damaged or the user could be injured.

Assurez-vous de bien resserrer chaque rondelle pour assurer la solidité du meuble. Dans le cas contraire, des pièces pourraient être endommagées ou l'utilisateur pourrait se blesser.

Asegúrese de apretar bien cada arandela para garantizar la solidez del mueble. De lo contrario, podría provocarse daño a las piezas o las personas.

## 3

### ASSEMBLY / ASSEMBLAGE / ENSAMBLAJE

#### Pedestal with 3 Drawers / Caisson à trois tiroirs / Modulo con tres cajones

**Assemble on the back edge**  
Assemblez sur la bordure arrière  
Realice el ensamblaje sobre el borde trasero

**Assembling sequence**  
Séquence d'assemblage  
Secuencia de ensamblaje  
**Parts / Pièces / Piezas:**

17 CA70B 81 18

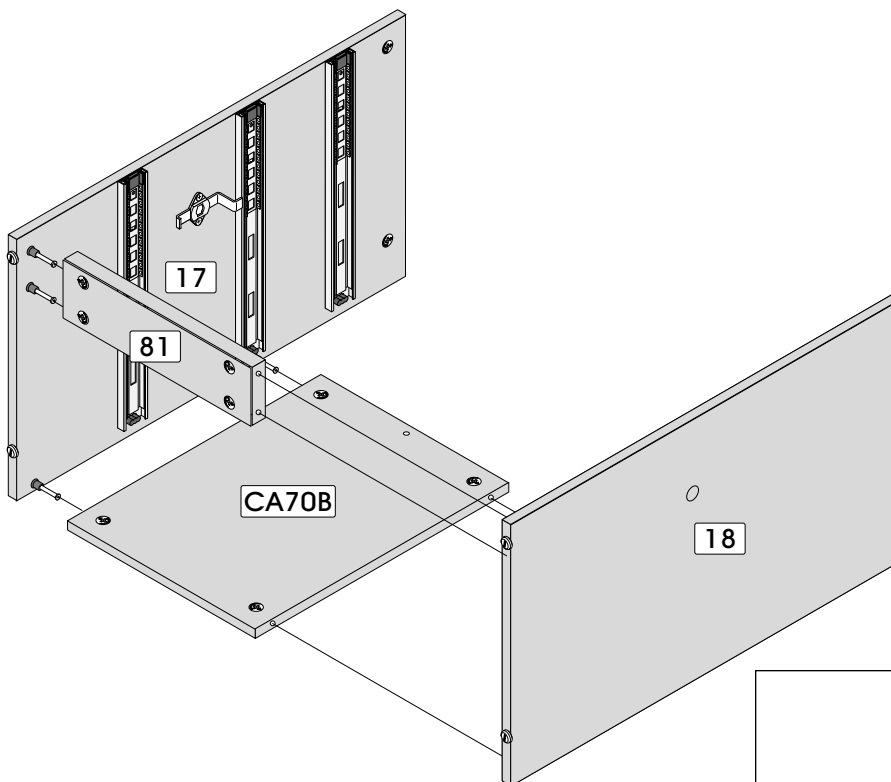

**two people are required to assemble and move this model.**  
deux personnes sont requises pour assembler et déplacer ce modèle.  
se necesitan dos personas para ensamblar y desplazar este mueble.

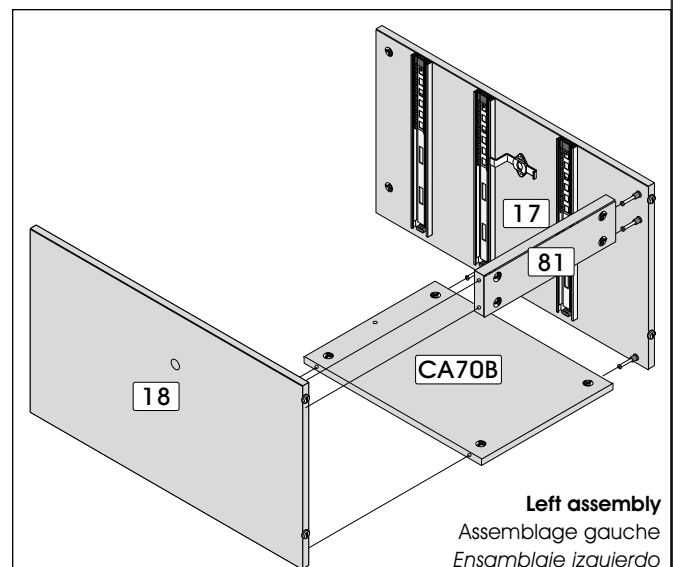

**Pedestal with 3 Drawers / Caisson à trois tiroirs / Modulo con tres cajones**

**3 possibilities / 3 possibilités / 3 posibilidades**

**Attention / Atención**

**Right assembly p.8 to 14**  
Refer to page 15 for the left assembly.

Assemblage droit p.8 à 14  
Référez-vous à la page 15 pour l'assemblage gauche.

Ensamblaje derecho p.8 a 14  
Vea la paje 15 para la ensablaje izquierdo.

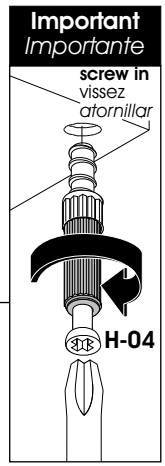
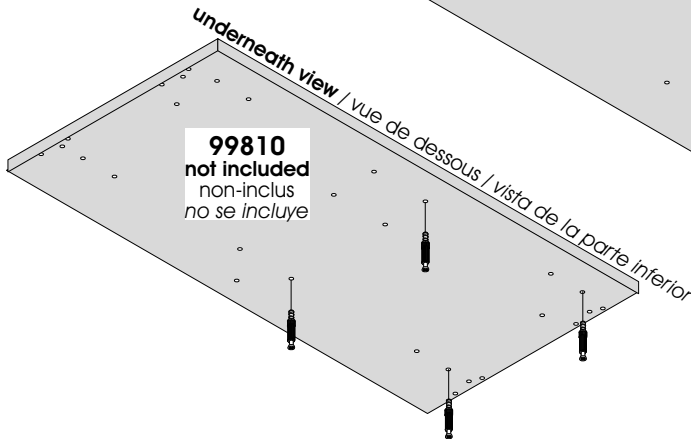
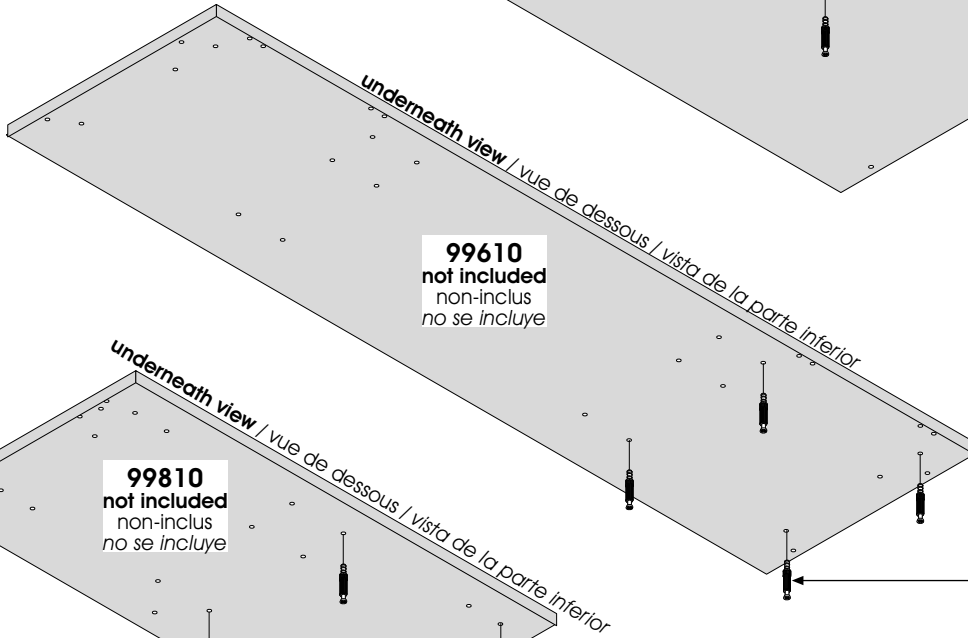
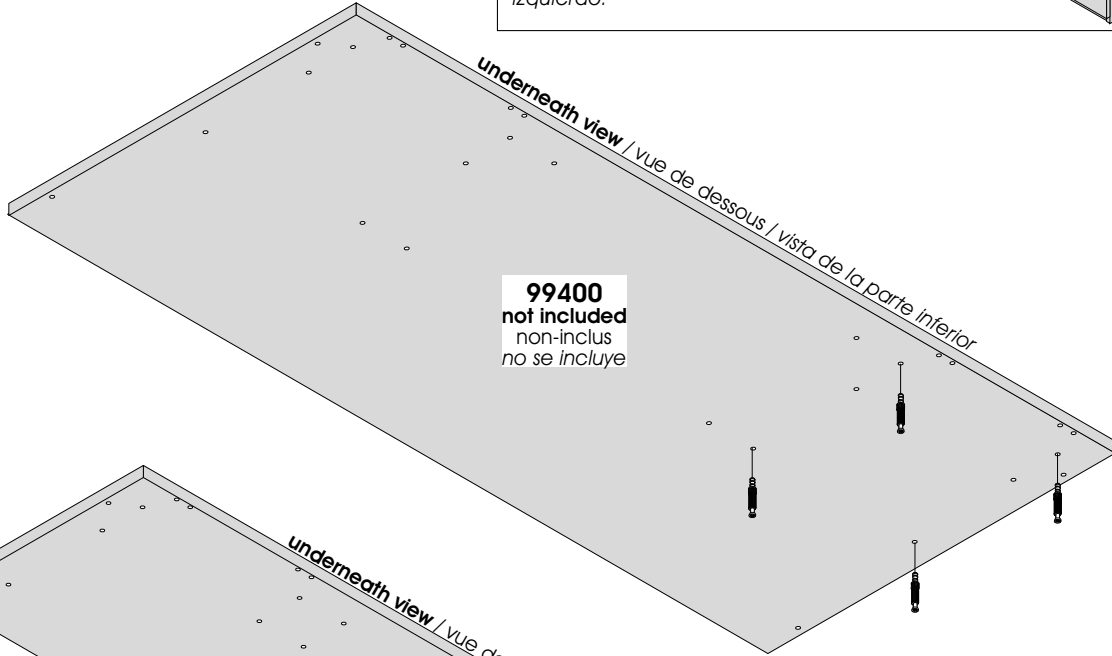
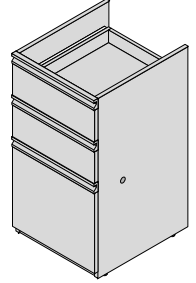

Code / Código      H-04  
Qty / Qté / Cant.    x 4

# 5

## INSTALLATION / INSTALLATION / INSTALACIÓN

Pedestal with 3 Drawers / Caisson à trois tiroirs / Modulo con tres cajones

### Assemble on the back edge

Assemblez sur la bordure arrière

Realice el ensamblaje sobre el borde trasero

### Assembling sequence

Séquence d'assemblage

Secuencia de ensamblaje

Parts / Pièces / Piezas:

17 18 + VR-212



**two people are required to assemble and move this model.**

deux personnes sont requises pour assembler et déplacer ce modèle.

se necesitan dos personas para ensamblar y desplazar este mueble.

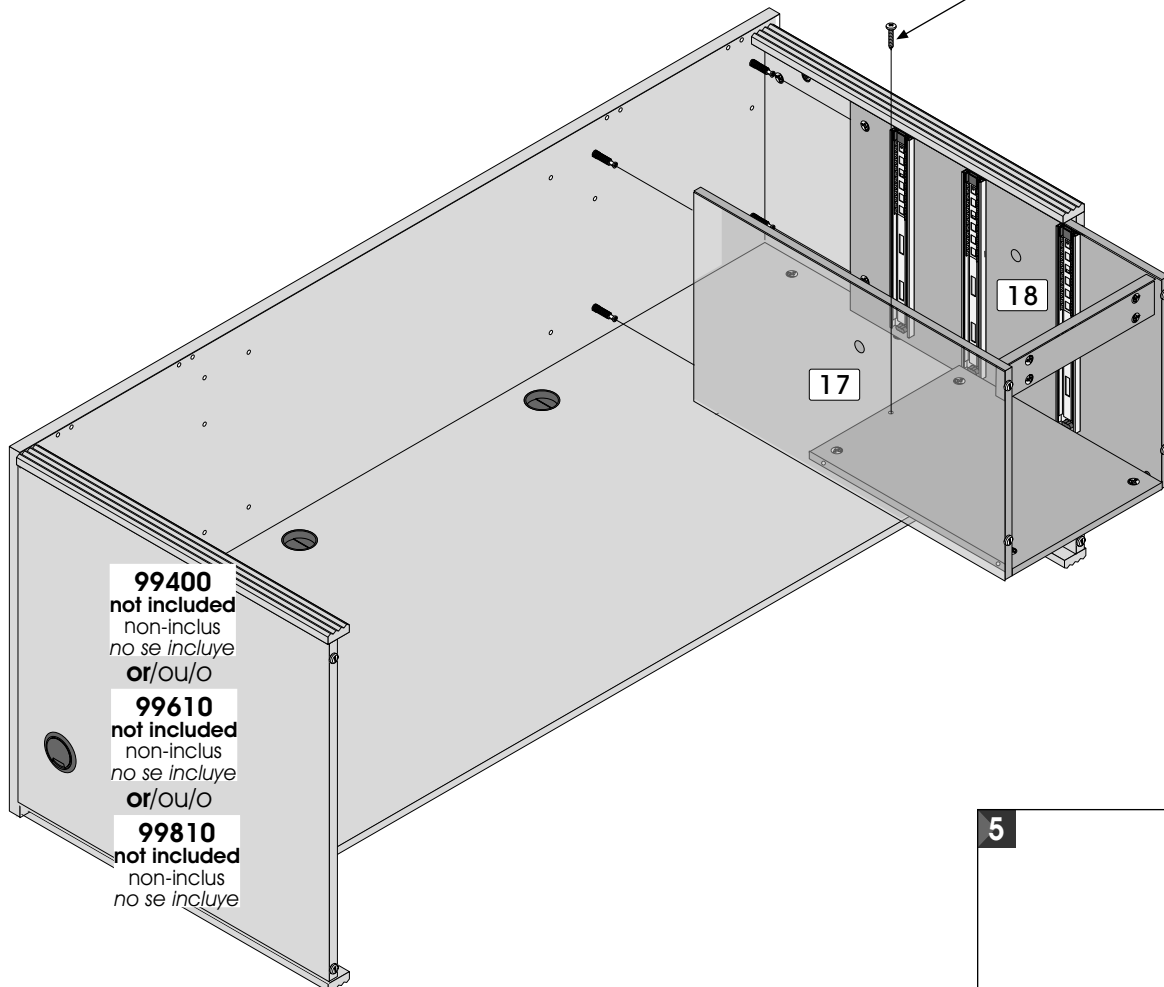
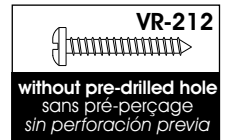
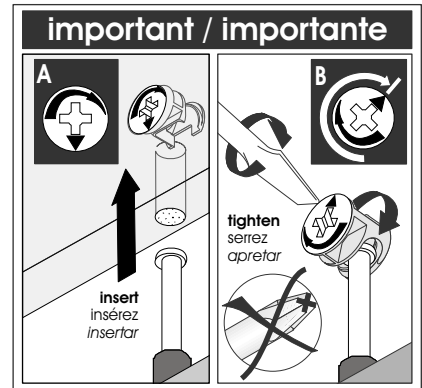

5



Code / Código VR-212

Qty / Qté / Cant. x 1

**Drawers / Tiroirs / Cajónes**

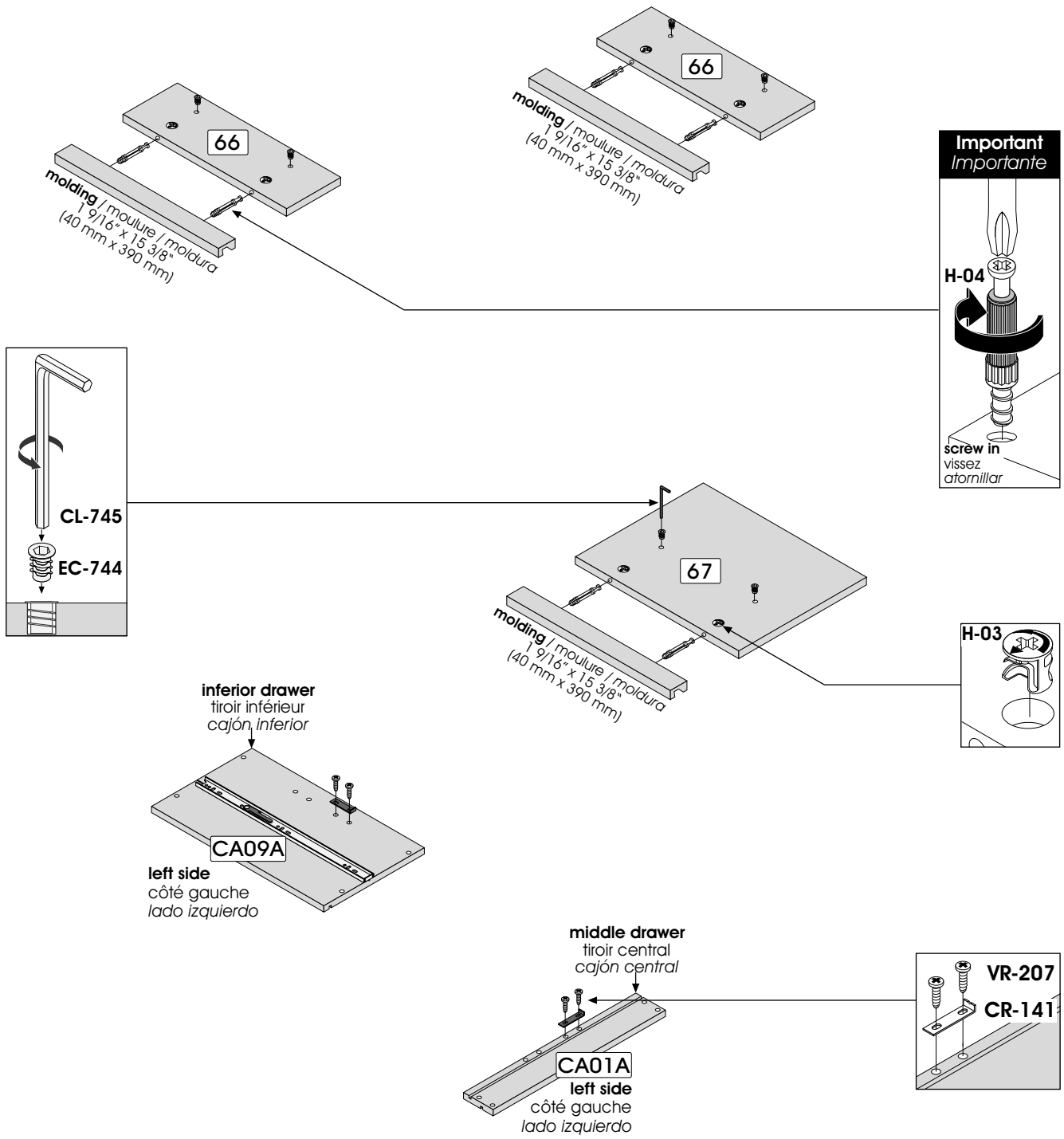

**6**

<b>Code / Código</b>	H-03	EC-744	H-04	CL-745	CR-141	VR-207
<b>Qty / Qté / Cant.</b>	x 6	x 6	x 6	x 1	x 2	x 4

# 7

## ASSEMBLY / ASSEMBLAGE / ENSAMBLAJE

### Superior Drawer / Tiroir supérieur / Cajón superior

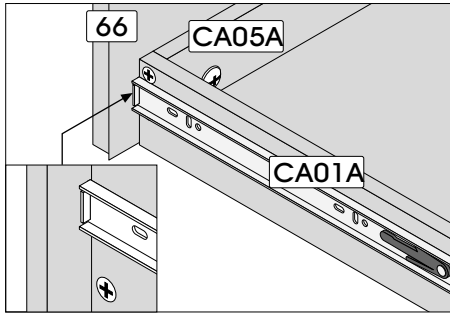

**Assembling sequence**  
 Séquence d'assemblage  
 Secuencia de ensamblaje  
**Parts / Pièces / Piezas:**

**CA05A CA01A CA01A** + **bottom / fond / fondo** + **CA05A 66**

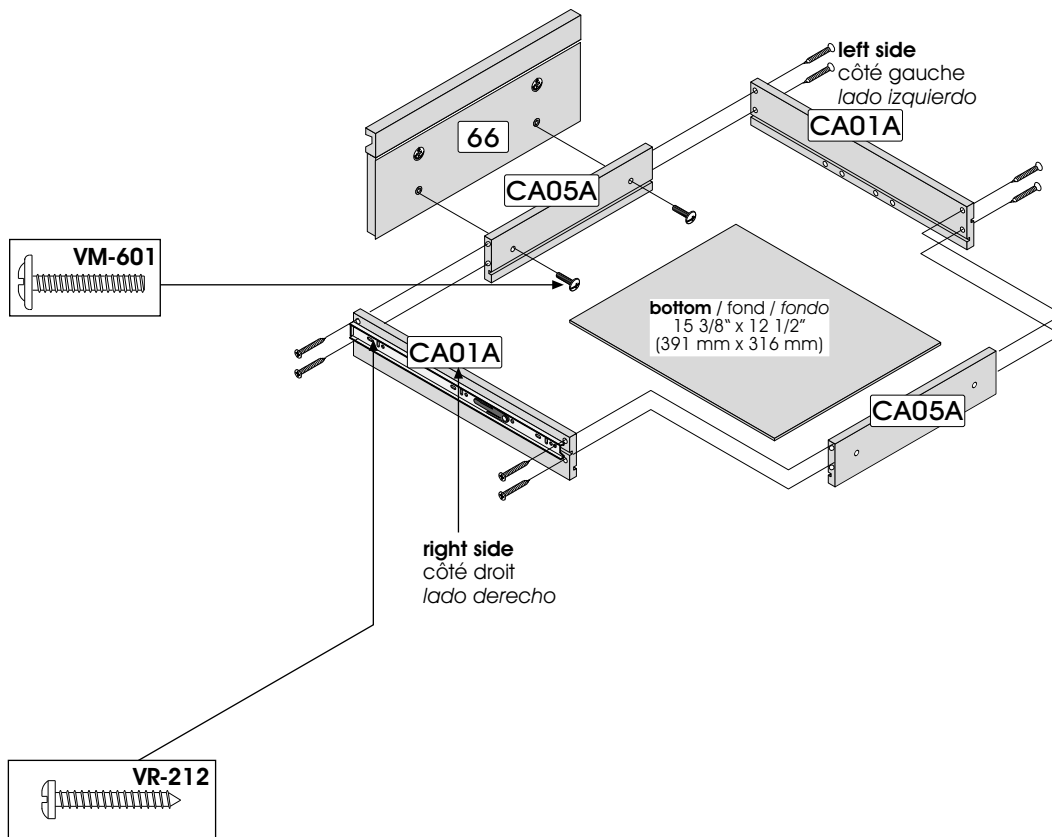

# 7



VM-601

x 2



VR-212

x 8

Code / Código

Qty / Qté / Cant.

Middle Drawer / Tiroir central / Cajón central

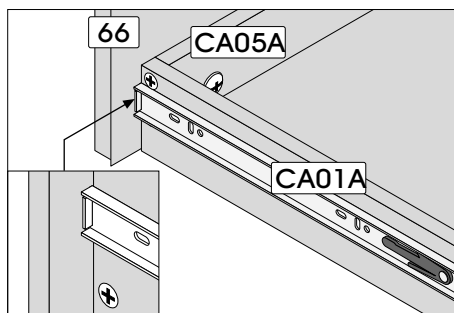

**Assembling sequence**  
 Séquence d'assemblage  
 Secuencia de ensamblaje  
**Parts / Pièces / Piezas:**

CA05A CA01A CA01A + bottom / fond / fondo + CA05A 66

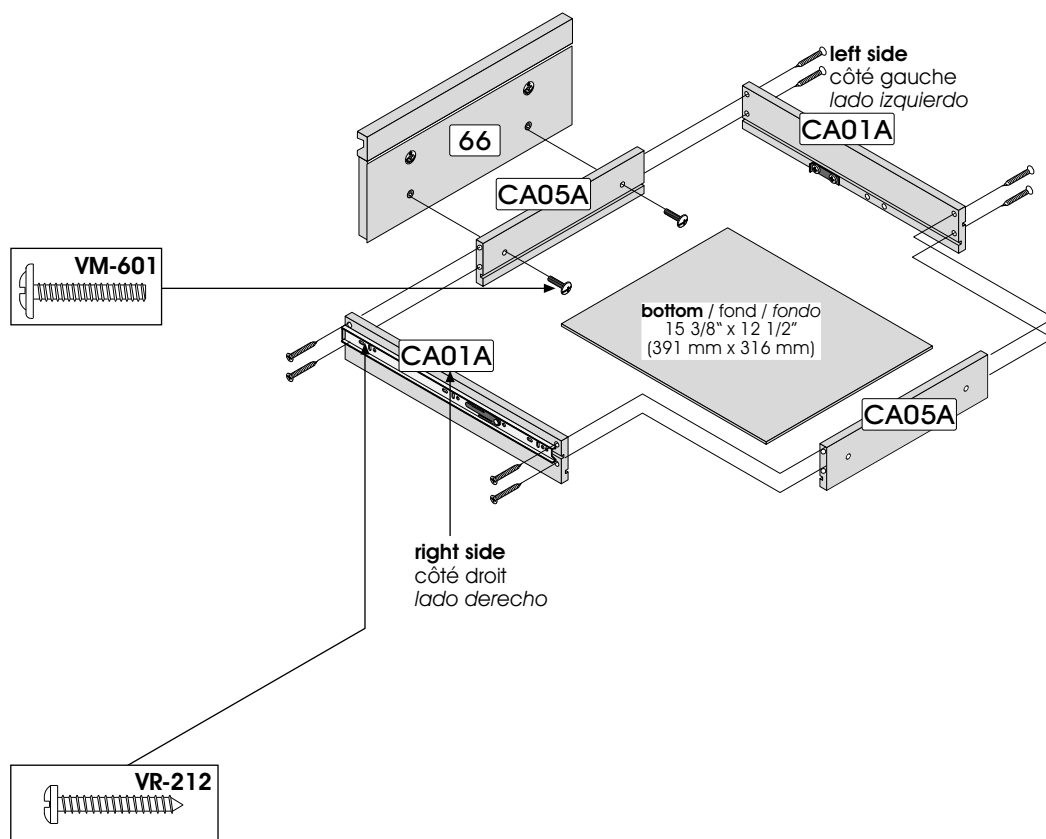

VM-601

x 2



VR-212

x 8

Code / Código

Qty / Qté / Cant.

Inferior Drawer / Tiroir inférieur / Cajón inferior

**Assembling sequence**  
 Séquence d'assemblage  
 Secuencia de ensamblaje

**Parts / Pièces / Piezas:**

CL13A EX-681 CA09A EX-702 CA09A EX-702 +

bottom / fond / fondo + CL13A EX-681 67

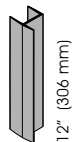
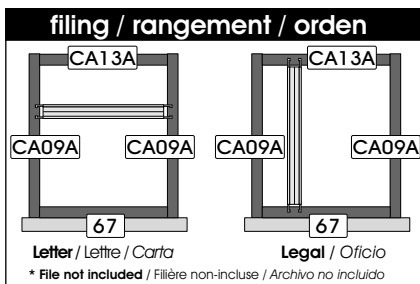
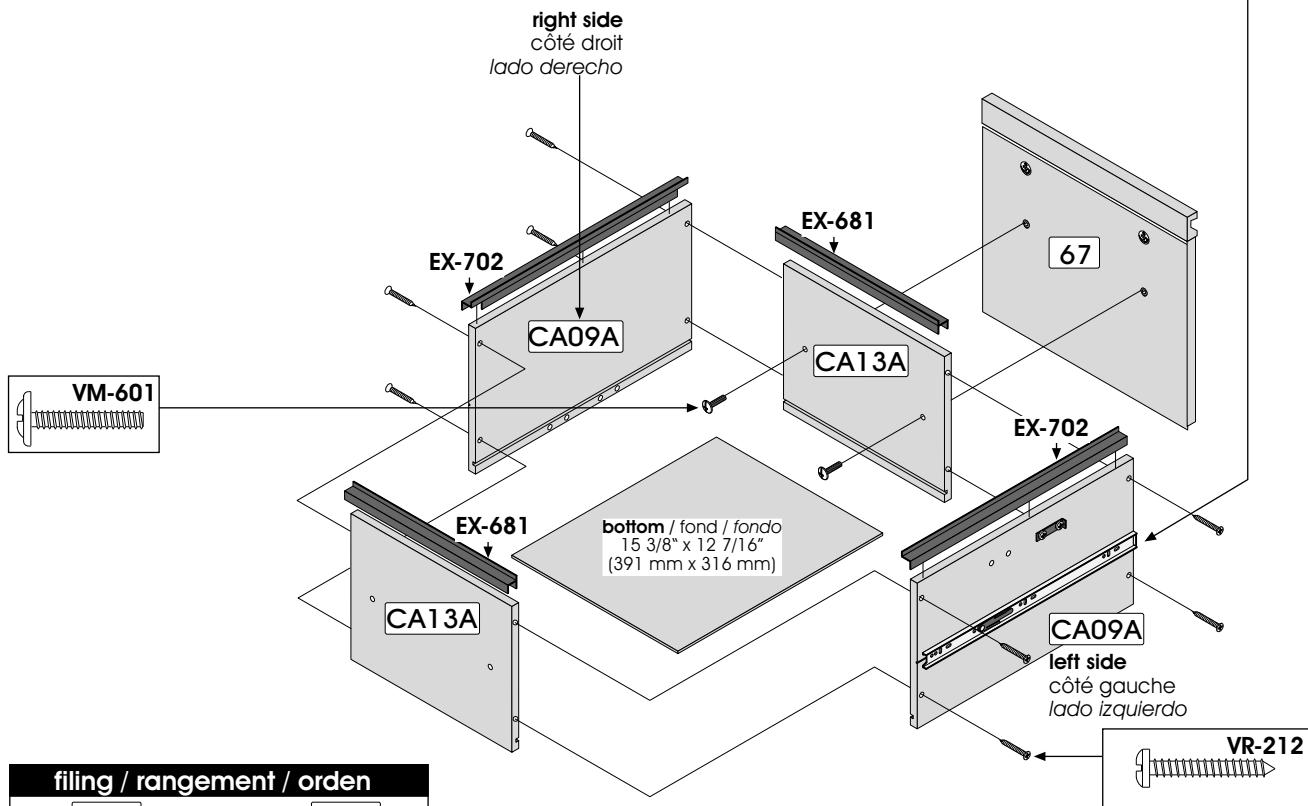
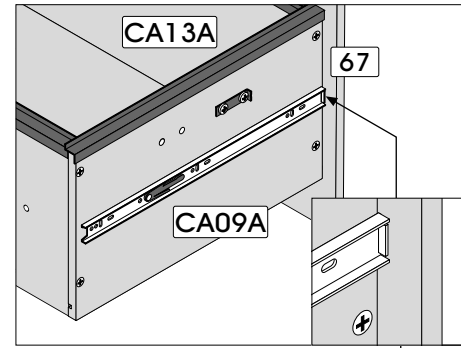

EX-681

x 2

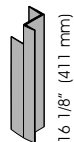

EX-702

x 2



VM-601

x 2



VR-212

x 8

Code / Código

Qty / Qté / Cant.

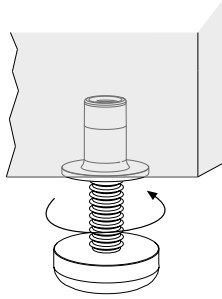

PA-844

**To level your furniture, use leg levelers.**

Pour niveler votre meuble utilisez les pattes ajustables.

Para nivelar su mueble utilice las patas ajustables.

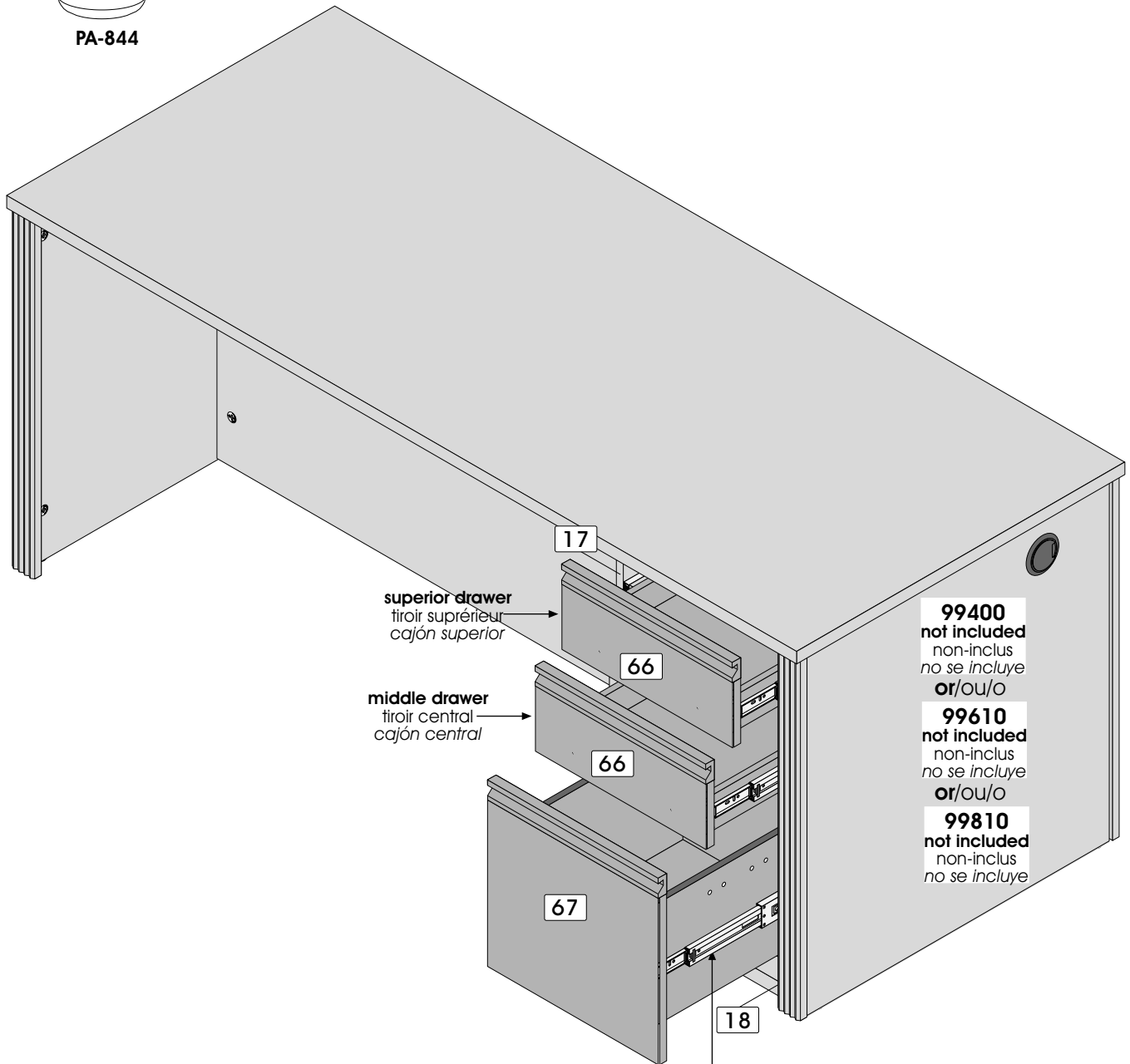

**99400**  
not included  
non-inclus  
no se incluye  
or/ou/o

**99610**  
not included  
non-inclus  
no se incluye  
or/ou/o

**99810**  
not included  
non-inclus  
no se incluye

**Go to step 11 to complete the assembly.**  
Aller à l'étape 11 pour compléter l'assemblage.  
Ir a la etapa 11 para completar el ensamble.

**Important/Importante**

**Ball bearings must be on front part of slider when installing drawers.**

Les roulements à billes doivent être sur la partie avant du coulisseau lors de l'installation des tiroirs.  
Los cojinetes de bolas deben ubicarse sobre la parte delantera de guía en el momento de instalar los cajones.

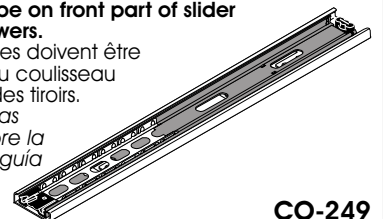

CO-249

**4 HARDWARE INSTALLATION / INSTALLATION DES QUINCAILLERIES / INSTALACIÓN DE LAS QUINCALLAS**

**Pedestal with 3 Drawers / Caisson à trois tiroirs / Modulo con tres cajones**

**Attention / Atención**

**Left assembly p.15 to 22**  
Refer to page 8 for the right assembly.

Assemblage gauche p.15 à 22  
Référez-vous à la page 8 pour l'assemblage droit.

Ensamblaje izquierdo p.15 a 22  
Vea la paje 8 para la ensablaje derecho.

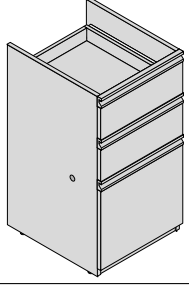

**3 possibilities / 3 possibilités / 3 posibilidades**

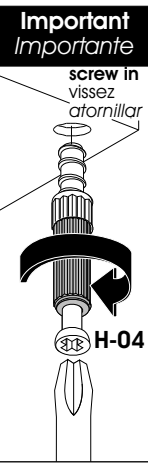
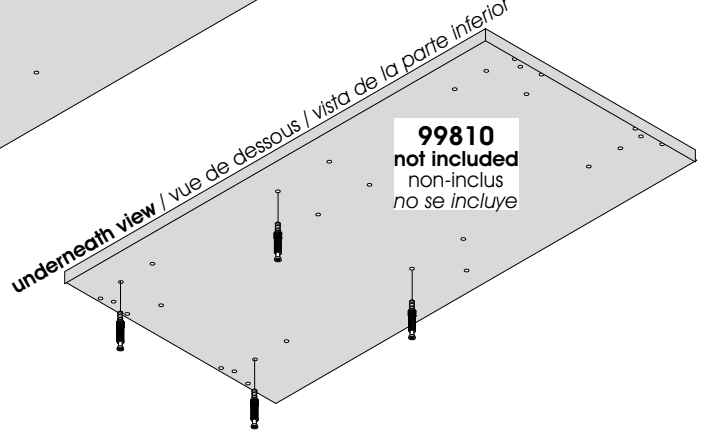
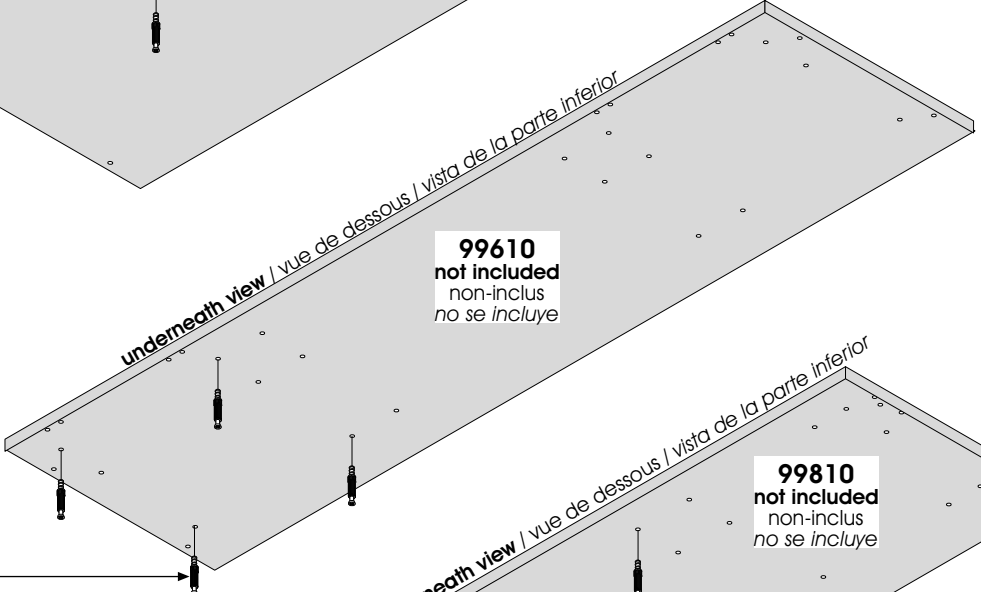
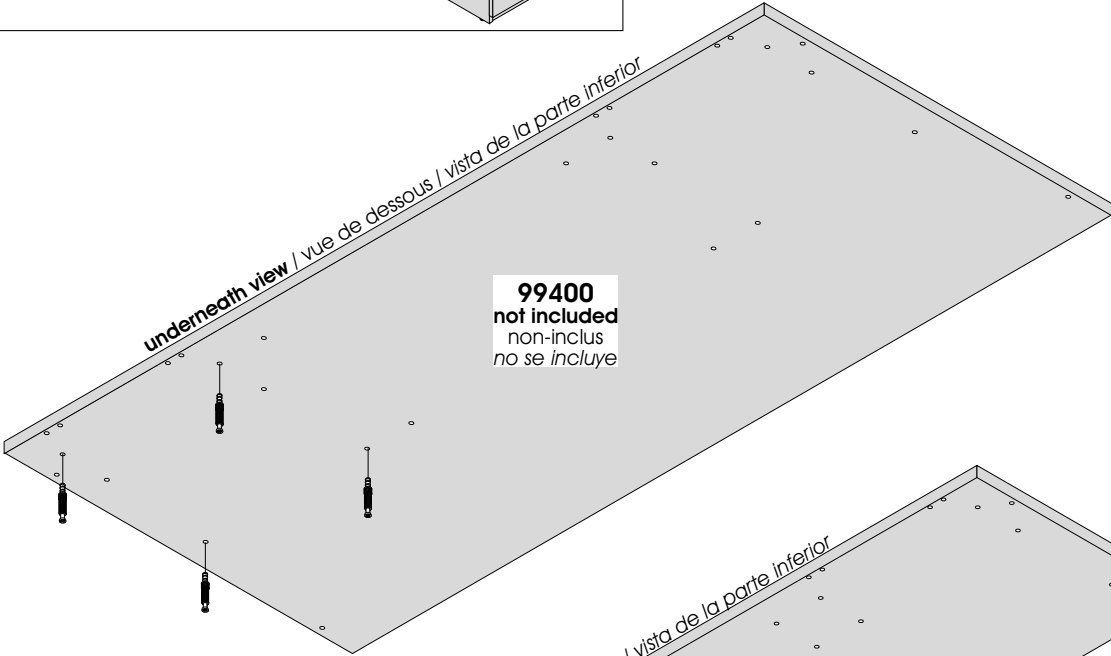

**4**



**Code / Código** H-04  
**Qty / Qté / Cant.** x 4

# 5

## INSTALLATION / INSTALLATION / INSTALACIÓN

Pedestal with 3 Drawers / Caisson à trois tiroirs / Modulo con tres cajones

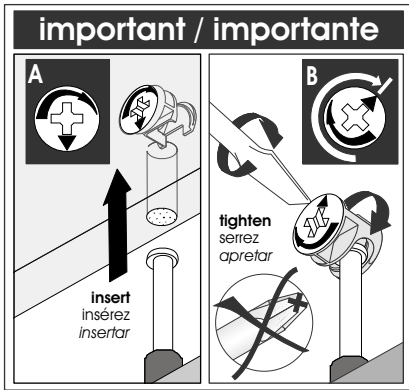

**Assemble on the back edge**  
 Assemblez sur la bordure arrière  
 Realice el ensamblaje sobre el borde trasero

**Assembling sequence**  
 Séquence d'assemblage  
 Secuencia de ensamblaje

**Parts / Pièces / Piezas:**

**17 18 + VR-212**

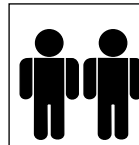

**two people are required to assemble and move this model.**

deux personnes sont requises pour assembler et déplacer ce modèle.  
 se necesitan dos personas para ensamblar y desplazar este mueble.

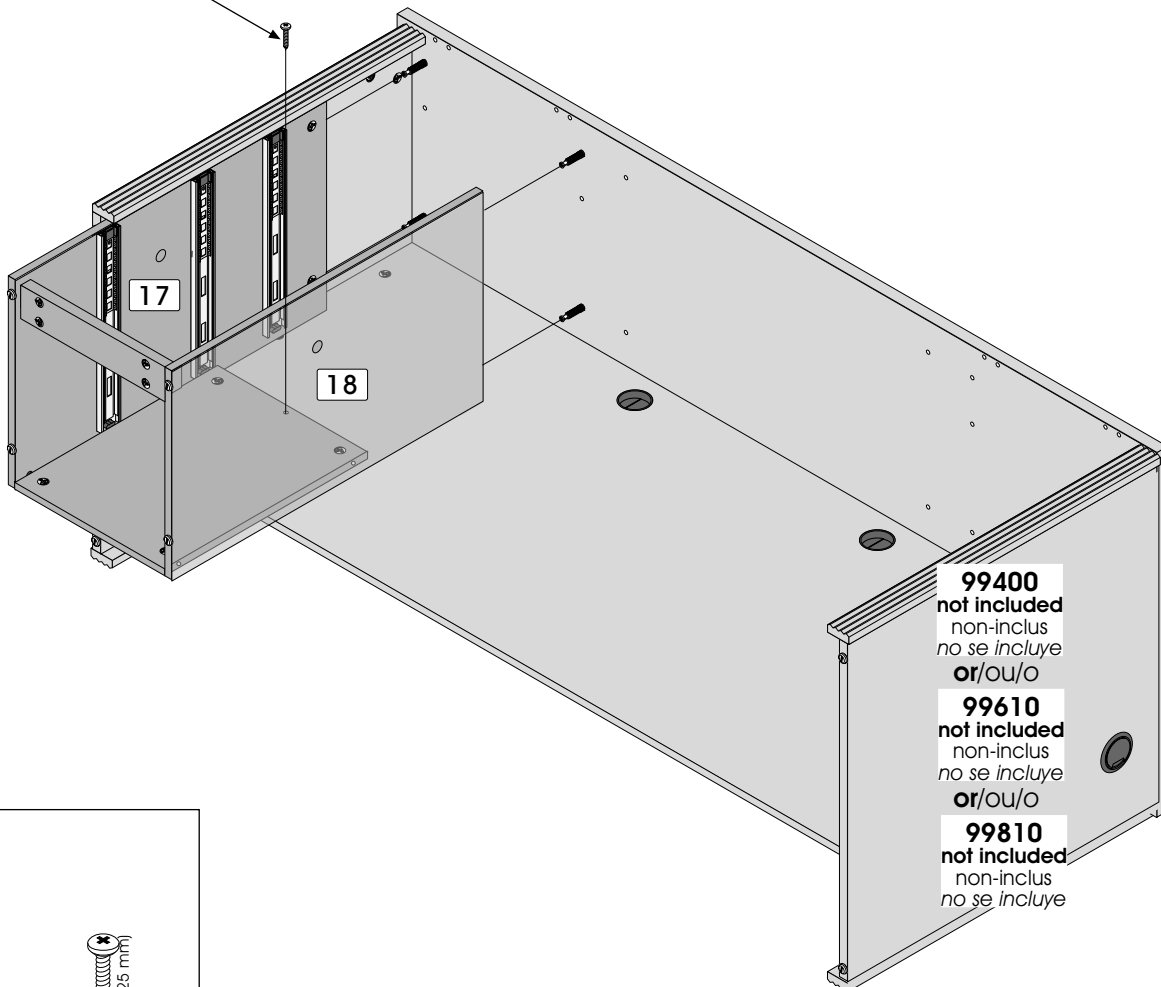
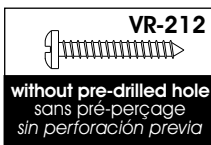

**99400**  
 not included  
 non-inclus  
 no se incluye  
 or/ou/o

**99610**  
 not included  
 non-inclus  
 no se incluye  
 or/ou/o

**99810**  
 not included  
 non-inclus  
 no se incluye

5







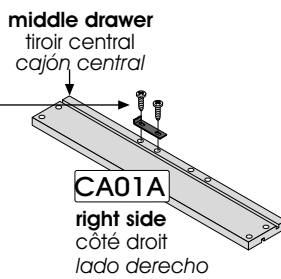
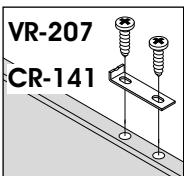
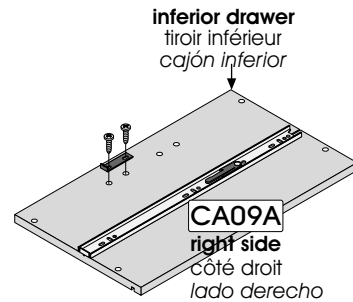
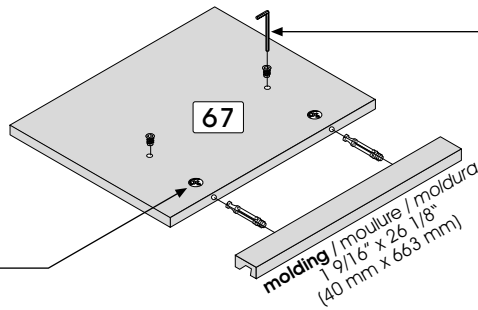
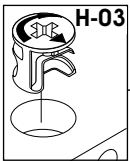
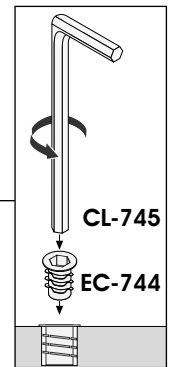
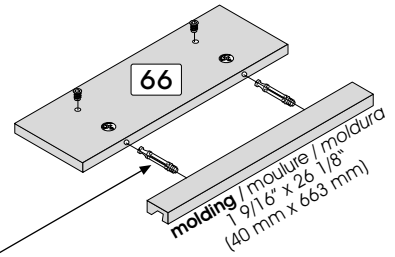
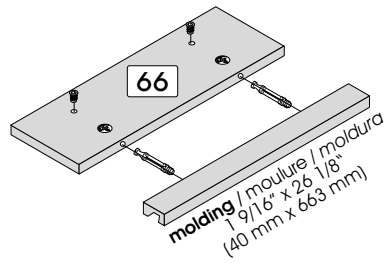
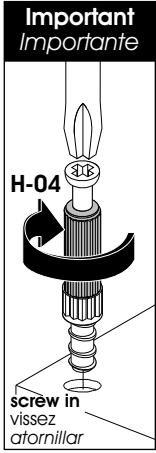

Code / Código VR-212

Qty / Qté / Cant. x 1

**Drawers / Tiroirs / Cajónes**



<b>Code / Código</b>	 <b>H-03</b>	 <b>EC-744</b>	 <b>H-04</b>	 <b>CL-745</b>	 <b>CR-141</b>	 <b>VR-207</b>
<b>Qty / Qté / Cant.</b>	<b>x 6</b>	<b>x 6</b>	<b>x 6</b>	<b>x 1</b>	<b>x 2</b>	<b>x 4</b>

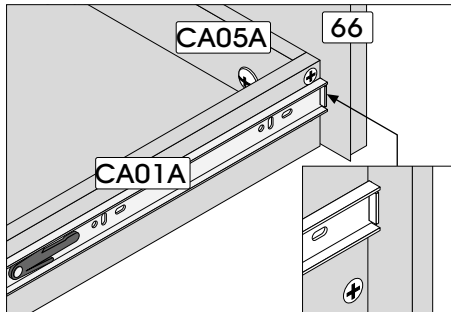

**Assembling sequence**  
 Séquence d'assemblage  
 Secuencia de ensamblaje  
**Parts / Pièces / Piezas:**

CA05A CA01A CA01A + bottom / fond / fondo + CA05A 66

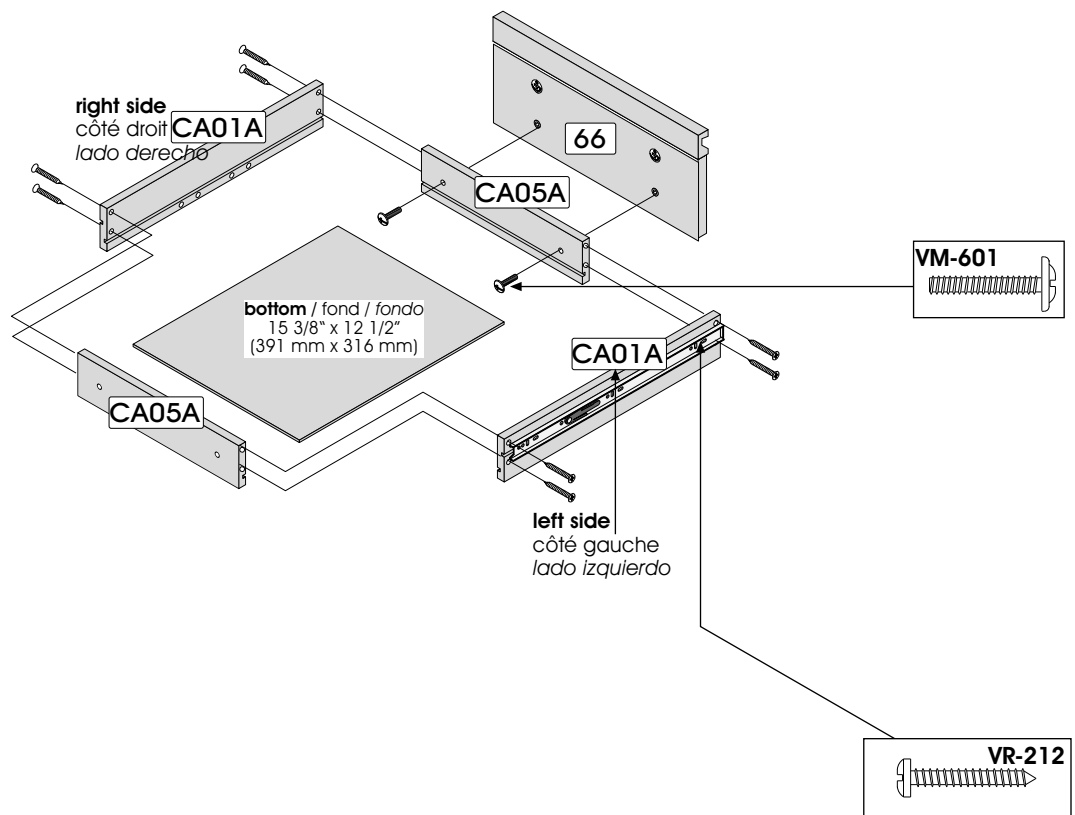

VM-601

x 2



VR-212

x 8

Code / Código

Qty / Qté / Cant.

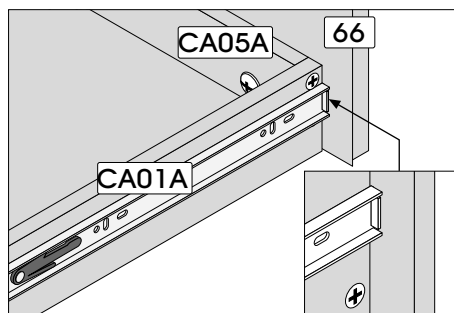

**Assembling sequence**  
 Séquence d'assemblage  
 Secuencia de ensamblaje  
**Parts / Pièces / Piezas:**

CA05A CA01A CA01A + bottom / fond / fondo + CA05A 66

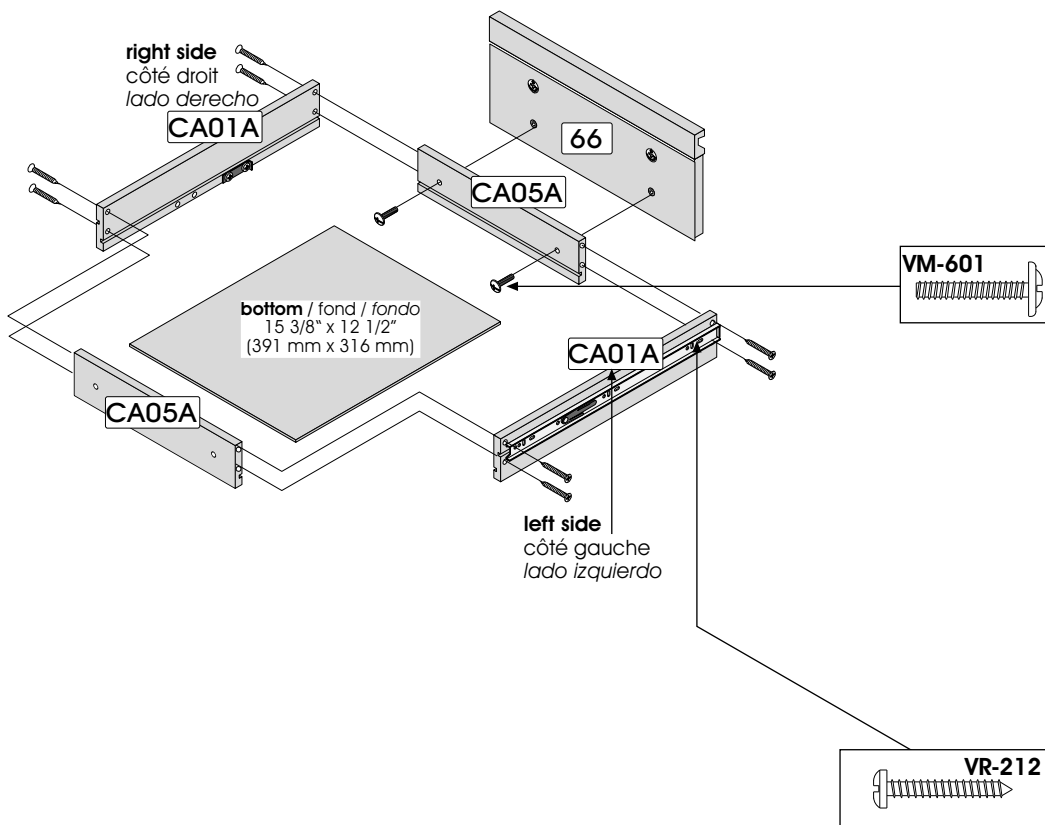

Code / Código VM-601

Qty / Qté / Cant. x 2



Code / Código VR-212

Qty / Qté / Cant. x 8

Code / Código

Qty / Qté / Cant.

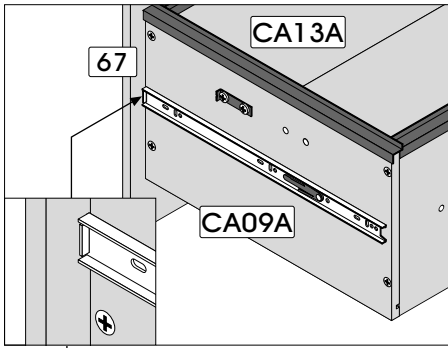

**Assembling sequence**  
 Séquence d'assemblage  
 Secuencia de ensamblaje  
**Parts / Pièces / Piezas:**

**CL13A**EX-681 **CA09A**EX-702 **CA09A**EX-702 +  
**bottom / fond / fondo** + **CL13A**EX-681 **67**

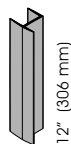
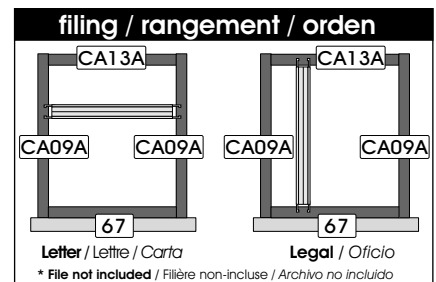
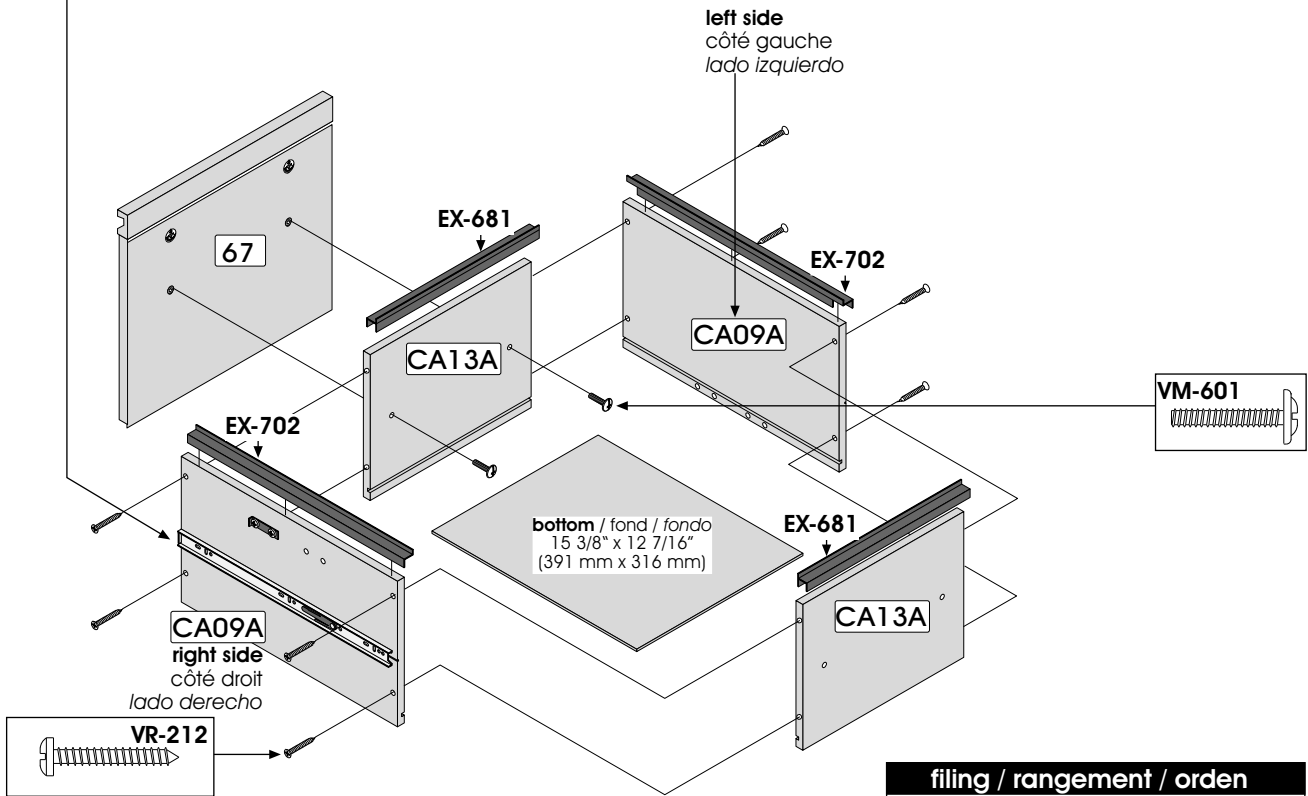

EX-681

x 2

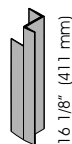

EX-702

x 2



VM-601

x 2



VR-212

x 8

Code / Código

Qty / Qté / Cant.

To level your furniture, use leg levelers.

Pour niveler votre meuble utilisez les pattes ajustables.

Para nivelar su mueble utilice las patas ajustables.

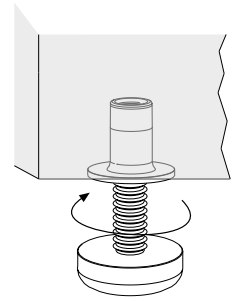

PA-844

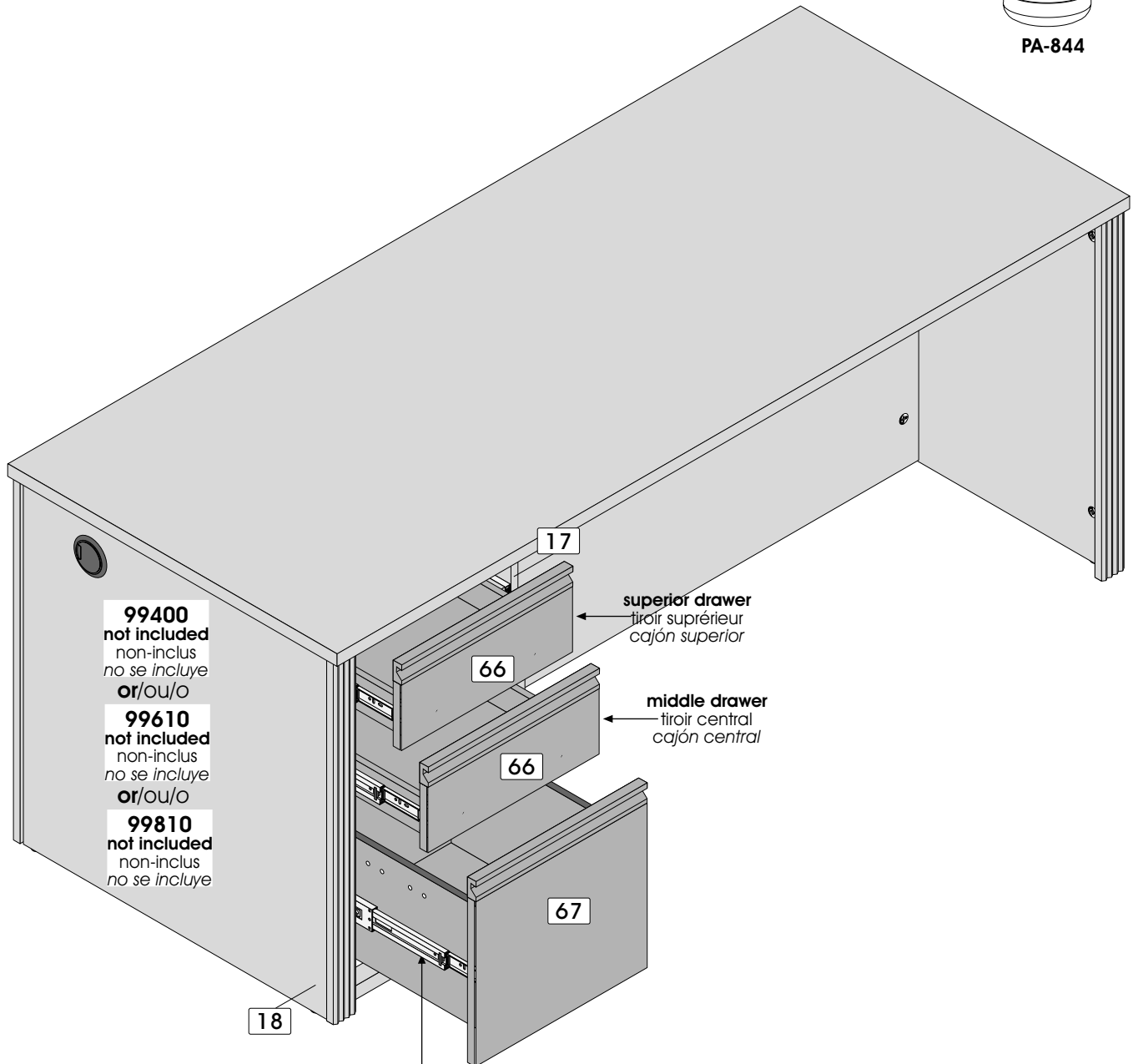

**99400**  
not included  
non-inclus  
no se incluye  
or/ou/o

**99610**  
not included  
non-inclus  
no se incluye  
or/ou/o

**99810**  
not included  
non-inclus  
no se incluye

superior drawer  
tiroir supérieur  
cajón superior

middle drawer  
tiroir central  
cajón central

### Important/Importante

**Ball bearings must be on front part of slider when installing drawers.**

Les roulements à billes doivent être sur la partie avant du coulisseau lors de l'installation des tiroirs.

Los cojinetes de bolas deben ubicarse sobre la parte delantera de guía en el momento de instalar los cajones.

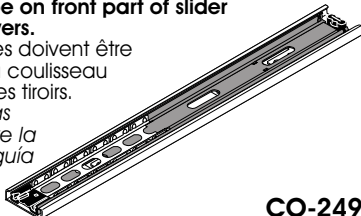

CO-249

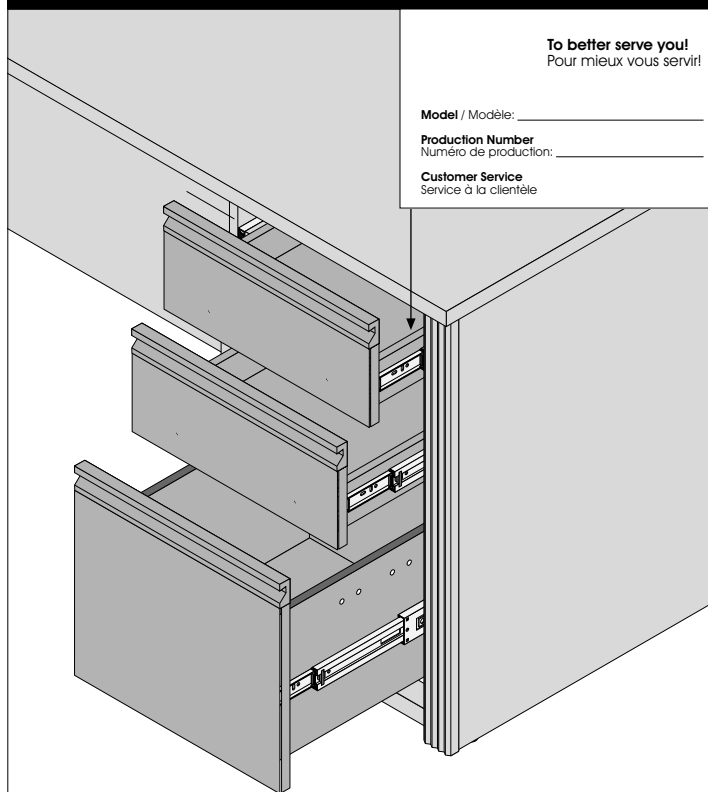
**Important/Importante**

**For future reference and to better serve you, please apply the self-adhesive sticker in an accessible space such as inside a drawer.**

Pour mieux vous servir en cas de besoin, veuillez apposer l'autocollant dans un endroit facilement accessible tel que l'intérieur d'un tiroir.

*Para uno mejor servicio en caso de necesidad, poner la etiqueta en uno lugar de fácil acceso como por ejemplo al interior de un cajón.*

**PRODUCT CARE / ENTRETIEN DU PRODUIT / MANTENIMIENTO DEL PRODUCTO**

**Avoid placing the furniture in the sunlight or near a source of heat. Use a soft dry cloth for dusting. To clean heavy dirt, use a cloth dipped in a solution of mild detergent and water. Avoid leaving wet objects on the surface or using commercial chemical cleaning products.**

Évitez d'exposer le meuble au soleil ou près de toute source de chaleur. Pour le nettoyage, utilisez un chiffon doux et sec. Pour la grosse saleté, utilisez un chiffon humidifié avec un peu de détergent dilué dans l'eau. Évitez de laisser des objets mouillés sur la surface de votre meuble ou d'utiliser des nettoyants chimiques.

*Evite exponer el mueble al sol o las fuentes de calor. Para limpiarlo, utilice un paño suave y seco. Para limpiar las manchas rebeldes, utilice un trapo húmedo con un poco de detergente diluido en agua. No deje objetos mojados encima del mueble ni utilice limpiadores que contengan productos químicos. química.*

**CONGRATULATIONS! YOU ARE NOW THE OWNER OF A QUALITY PRODUCT**  
**FÉLICITATIONS! VOUS AVEZ MAINTENANT EN VOTRE POSSESSION UN PRODUIT DE QUALITÉ**  
**FELICITACIONES! AHORA ES USTED DUEÑO DE UN PRODUCTO DE CALIDAD.**

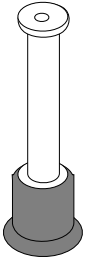

**You are at a step of hardware installation and some H-36 are missing: Before calling to order your missing bolts (H-36), please make sure you have not installed any bolts (H-36) in the wrong place. To remove a bolt (H-36) which is not in the correct place, please refer to your instruction manual.**

Vous êtes à une étape d'installation de quincaillerie et il vous manque des H-36 : Avant d'appeler pour commander des boulons (H-36), assurez-vous de ne pas avoir installé des boulons (H-36) au mauvais endroit. Pour enlever un boulon (H-36) mal situé, consultez le feuillet d'instructions.

*Usted está en alguna etapa de la instalación de quincallas y le faltan las H-36 : Antes de llamar para pedir los pernos (H-36), asegúrese de que no los haya instalado en el lugar equivocado. Para retirar un perno (H-36) mal puesto, consulte el folleto de instrucciones.*

**How to separate and install your CO-249 and CO-684 slides:**

**The CO-249 & CO-684 slides consist of two sections which you must separate. To separate the slides, please refer to your instruction manual. The slides are installed on distinct parts which will be re-grouped only when the drawers are installed on the furniture.**

Comment séparer et installer les coulisseaux CO-249 et CO-684 :

Les coulisseaux CO-249 et CO-684 sont constitués d'une partie que vous devez séparer en deux sections. Pour séparer le coulisseau, référez-vous au feuillet d'instructions. Les coulisseaux sont installés sur deux pièces distinctes et seront regroupés seulement lors de l'installation des tiroirs dans le meuble.

*Cómo separar y instalar las guías correderas CO-249 y CO-684 :*

*Las guías correderas CO-249 y CO-684 están constituidas por una parte que usted debe separar en dos secciones. Para separar las guías correderas, consulte el folleto de instrucciones. Las guías correderas se instalan en dos piezas distintas y sólo serán reagrupadas una vez que se instalen los cajones en el mueble.*

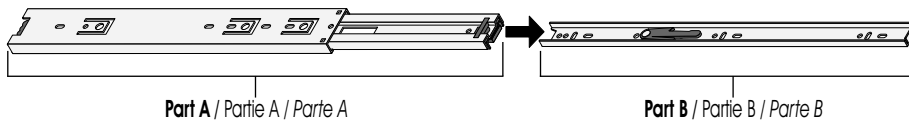

**The doors on your furniture are crooked or the space between the doors is uneven:**

**It is very important to install the hinges and hinge plates on the correct parts while respecting the instruction manual.**

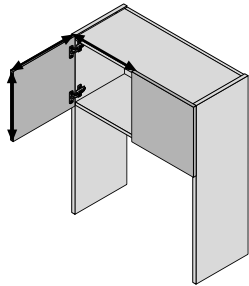

Les portes de votre meuble sont croches ou l'espace qui les sépare est inégal :

Il est important d'installer les pentures et les plaques sur les bonnes pièces en respectant le feuillet d'instructions.

*Las puertas de su mueble están chuecas o el espacio que las separa es desigual :*

*Es importante instalar las bisagras y las placas sobre las piezas adecuadas respetando el folleto de instrucciones.*

**The drawers on your furniture are crooked or the space between the drawers is uneven:**

**While referring to the section indicating the actual sizes of the screws in your instruction manual , please insure that you are using the correct size screws needed when installing your drawer slides and drawer fronts. They must be installed straight. While installing the drawer front, make sure that the correct side is facing up.**

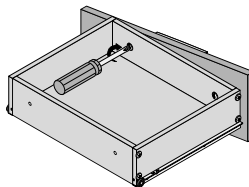

Les tiroirs de votre meuble sont croches ou l'espace qui les sépare est inégal :

En vous référant au tableau de vis grandeur réelle du feuillet d'instructions, assurez-vous que vous avez utilisé les bonnes vis lors de l'installation des coulisseaux ainsi que du devant de tiroir et qu'elles sont posées bien droites. Assurez-vous également que le devant du tiroir n'est pas assemblé à l'envers.

*Los cajones de su mueble están chuecos o el espacio que los separa es desigual :*

*Consulte la tabla de tornillos en tamaño real del folleto de instrucciones y asegúrese de que haya utilizado los tornillos adecuados durante la instalación de las guías correderas así como también la parte delantera del cajón y que éstos estén puestos bien derechos. Asegúrese también de que la parte delantera del cajón no esté ensamblada al revés.*



**For more information or to discover our new products**

Pour toute information ou pour découvrir nos nouveaux produits

*Para obtener más información o para obtener nuevos productos*



**FOR LONG TIME**  
POUR LONGTEMPS  
*POR MUCHO TIEMPO*