

Assembly Instruction

Step 1

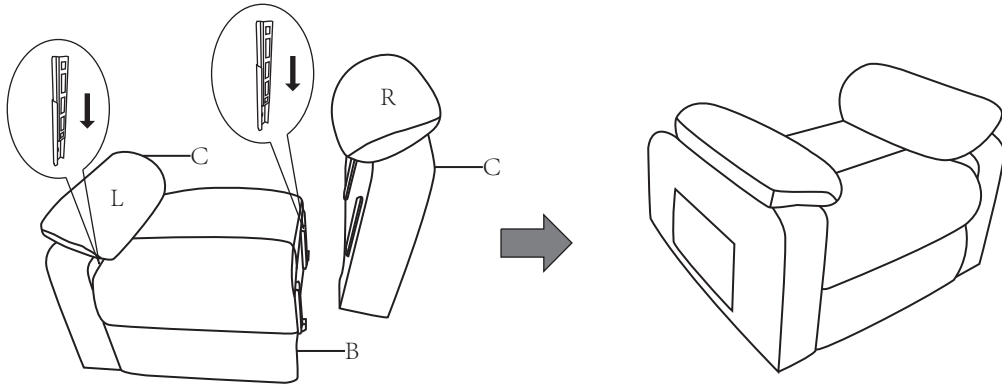

Step 2

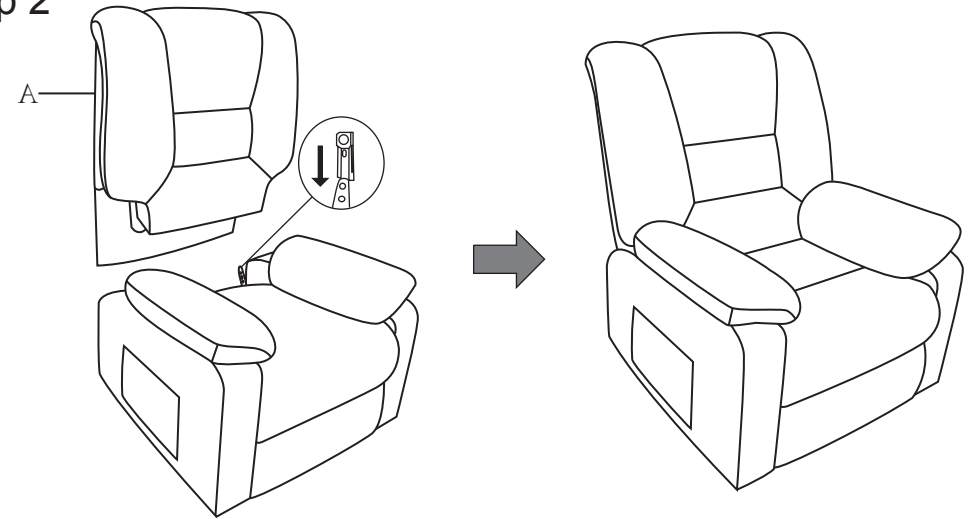

Step 3

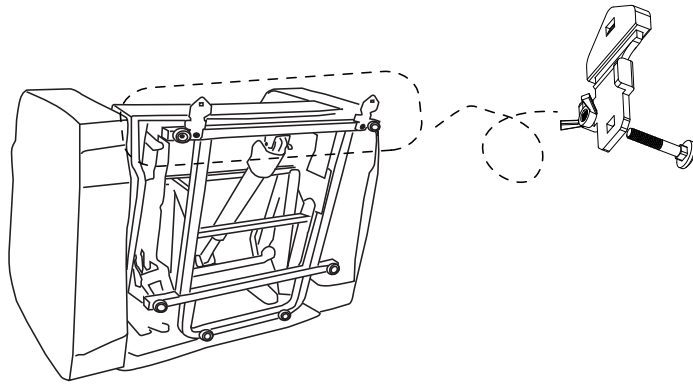

Step 4

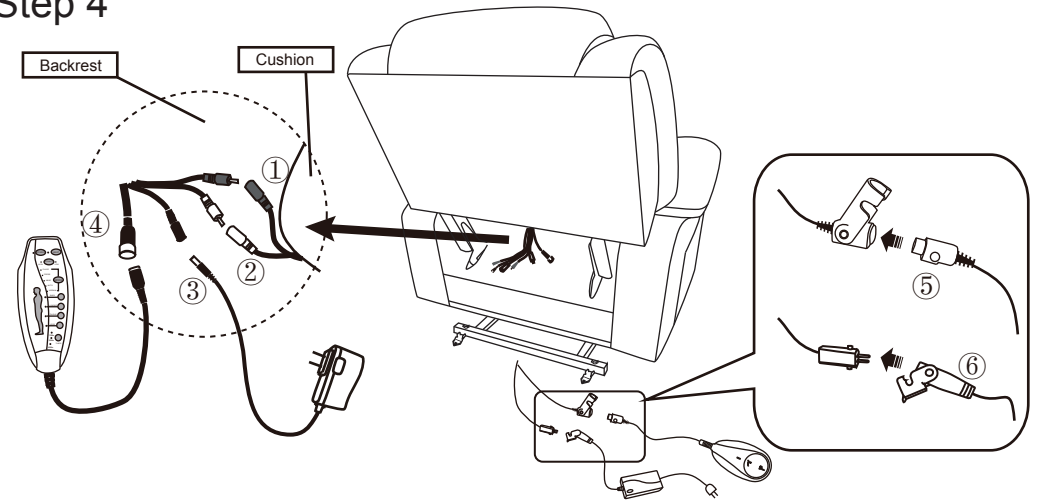

A*1

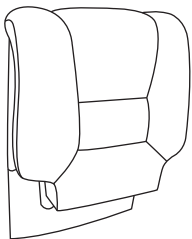

B*1

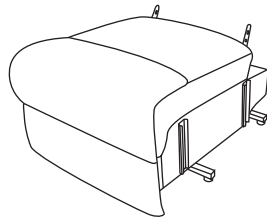

C*2

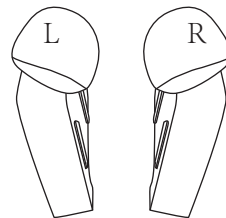

D*1

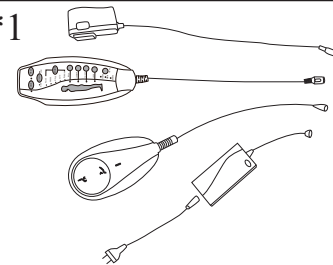

E*1

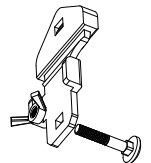

Remote Operation Instruction

