

Assembly Instructions

MODEL:AM944

PRODUCT SIZE(LxWxH): 8X8

PLEASE READ CAREFULLY BEFORE ASSEMBLY

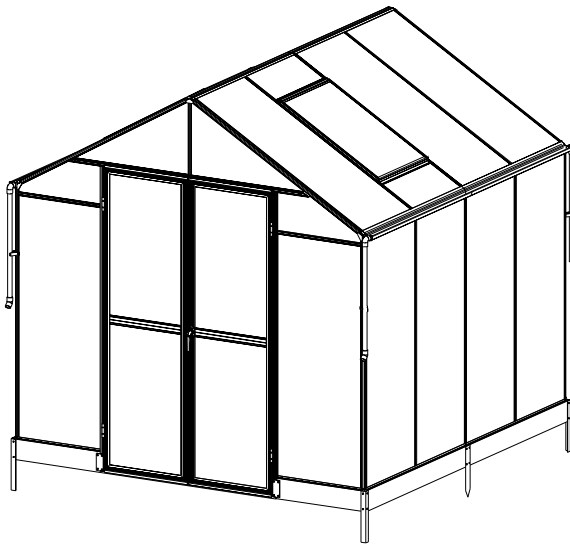

Greenhouse 8x8 FT Assembly Instruction

SKU:

1007040207B(BOX 1)

1007040208B(BOX 2)

Arrive in 2 separate boxes and may not be part of the same shipment; Please install the product after receiving all the packages.

Email Address:cs@howedirect.com

Tel: 901-347-2181

Service Time: 8 am - 5 pm (central time) Monday- Friday.

If no one picks up, please call several more times

2024/5/16

CONTENTS

1. Assembly Advice	Page 1
2. Product Features	Page 2
3. Parts List	Page 3 -5
4. Door Assembly	Page 6 - 10
5. Roof Vent Assembly	Page 11 - 13
6. Base Assembly	Page 14-15
7. Framework & Glazing Assembly	Page 16 - 37

Assembly and Maintenance Advice

1. For safety purposes, we strongly recommend that this product is assembled by at least two people.
2. Some components have sharp metal edges. Please be careful when handling metal components. Please wear gloves, shoes and safety goggles during assembly.
3. Lay all of the components on a soft carpet or blanket to avoid any scratches or damages.
4. DO NOT climb or stand on the roof. Heavy articles should not be leaned against the greenhouse.
5. Keep the roof and gutter clear of snow, dirt & leaves. Allowing snow to build up on the roof may damage the product.
6. Unlike steel, if the paint finish is scratched this will not harm the aluminium underneath.
7. When your product needs cleaning, use a mild detergent solution and rinse with cold clean water. Do not use acetone, abrasive cleaners or strong detergents to clean the panels.

Tools Provided:

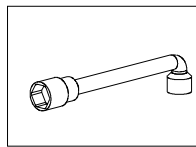
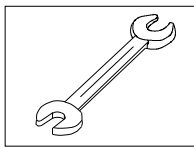
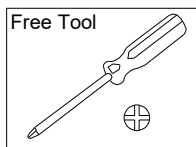

Tools Required when Assembly (Not Provided)

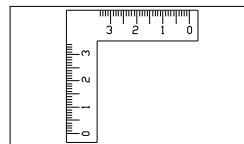
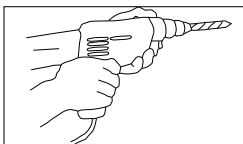
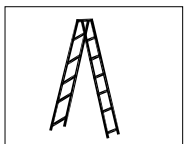
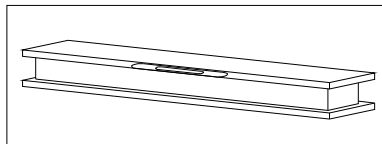
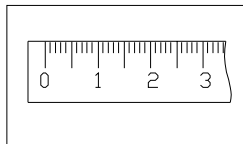
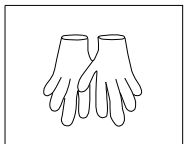

Assembly at least by two Persons



Important:

Rubber is not provided if you choose polycarbonate sheet as glazing panel.

Functions and Features:

1. The strong two part eaves beam includes an integral gutter. Downpipes are also included as standard so you can collect rainwater.

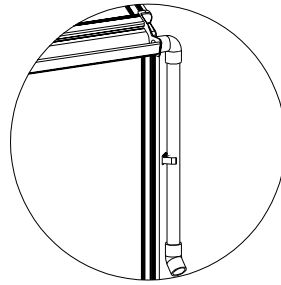

2. Manual window handles are included as standard with the roof vents. If required, automatic roof vent openers are available as an inexpensive optional extra.

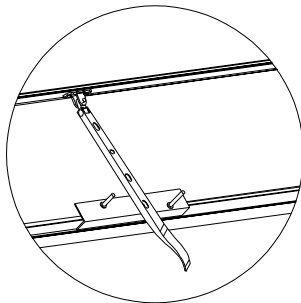

Manual Opener

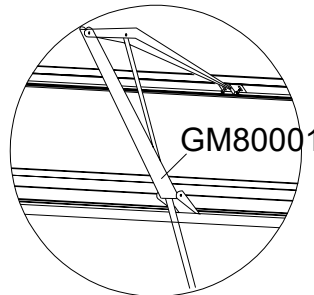

Automatic Opener

GM80001 is sold separately



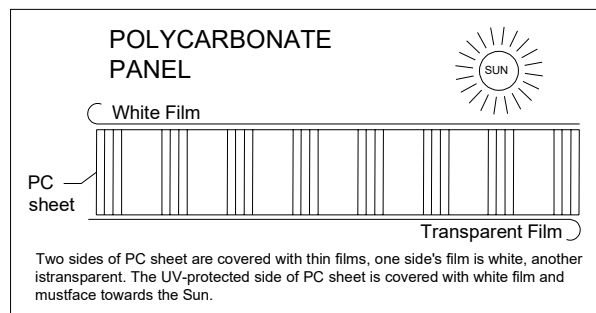



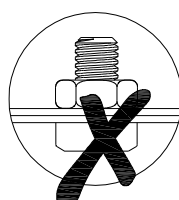
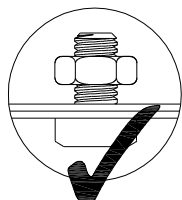

3. Remove approximately 2 inches of film from all sheet edges before installing and remove all film immediately after the construction is completed. Please ensure that the side with the white film faces outwards.

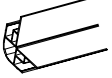
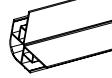

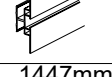
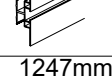
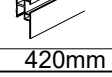

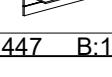
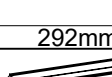

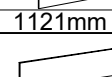

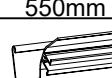
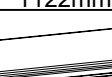
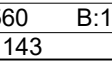
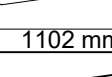
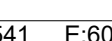

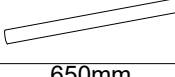
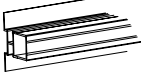
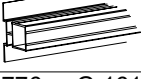
4. This quality greenhouse features self-tapping screws to provide strong joints. As the name suggests, the screws tap their own thread. Driving in self-tapping screws requires more force than conventional screws. A powered screwdriver is therefore recommended.

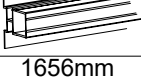
5. Nuts not to be tightened before the end of assembly! Unless otherwise stated, do not tighten the bolts/nuts/screws until the shed is finally erected!



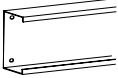

	PART	NO	QTY
1		L01A	1
	1447mm	L01B	1
2		L01E	1
	1447mm	L01F	1
3		L01C	2
	1247mm	L01D	2
4		L02A	4
	1447mm		
5		L02B	4
	1247mm		
6		L02C	2
	420mm		
		L04A	2
	540mm		
7		L03A	2
	A:1447 B:1247	L03B	2
8		L05B	2
	292mm		
9		L06B	2
	1121mm		
10		L07B	4
	1121mm		
11		L08B	4
	1121mm		
12		L08E	1
	550mm	L08F	1
13		L09B	4
	1122mm		
14		L10A	2
		L10B	1
	A:560 B:1122 C:1143	L10C	1
15		L23B	10
	1102 mm		
16		L23G	2
	G:541 E:600	L23E	3



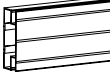

	PART	NO	QTY
17		L25	4
	650mm		
18		L26A	1
	A:1776 H:1610	L26H	1
19		L26B	1
	B:1776 G:1610	L26G	1
20		L26C	2
	1656mm		
21		L26D	1
	1656mm		
22		L02D	6
	540mm		

	PART	NO	QTY
		A2	2
	A2:579 B2:1150	B2	6
		D306	4
		D307	3
		D317	2
		H152	1









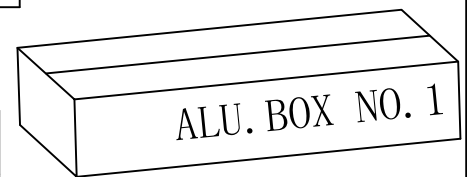

door

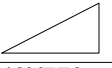
	PART	NO	QTY
23		L16A	2
	1760mm		
24		L17	2
	464mm		
25		L18A	2
	546mm	L18B	2
26		L18C	1
	27	1792mm	L18D









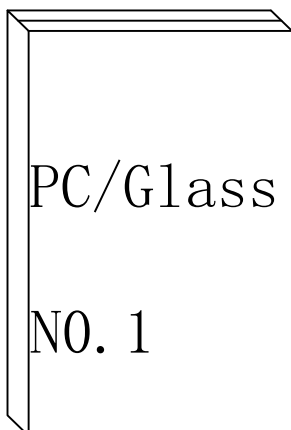







windowsX2









	PART	NO.	QTY.
28		L11A	2
	554mm	L12A	2
29		L19	4
	748mm		
		L20	2
	554mm		
		L21	2
	554mm		

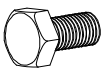

PART	NO	QTY
 245X558mm	Y1	2
 1425X558mm	Y2	6
 448X776mm	Y3	2
 245X558mm	Y4	2
 1468X558mm	Y6	8
 1271X558mm	Y7	6
 448X776mm	Y8	2
 243X558mm	Y9	6
 726X552mm	Y10	2
 841X484mm	Y11	4



PART	NO	QTY
	J55	2
	J56R	2
	J56L	2
	J94	4
	J93	4
	J165	4
	J166	4
	A01	2
	A03	2
	A51	4
	D17	5
	D25	2
	D26	1
	D45	8
	D309	4
	D47	1

PART	NO	QTY
	S01 M6X12	237
	M01 M6	237
	Z02 Ø4X16D	32
	Z04 Ø4X8	4
	Z08 M4.2X16	71
	Z17 M4.8X16	8
	D114	14
	S69 M6X60	14
	S76 M4X32	2

Tools Provided:

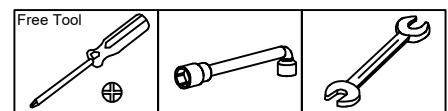

PART	NO	QTY
	Y1	2
	Y2	6
	Y3	2
	Y4	2
	Y6	8
	Y7	6
	Y8	2
	Y9	6
	Y10	2
	Y11	4

Panel Exploded View

Back Wall

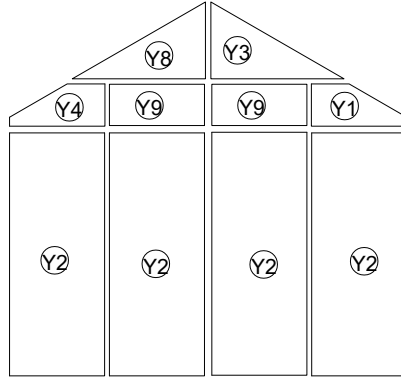



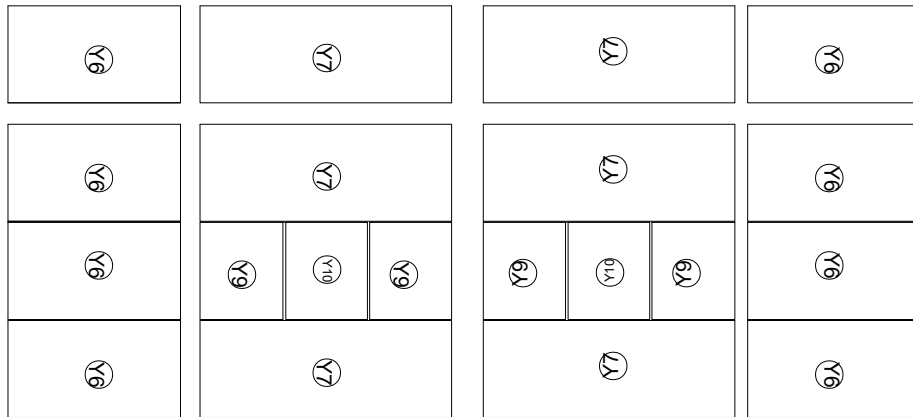



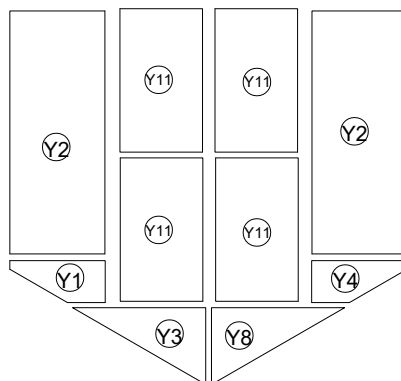

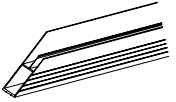

Side Wall

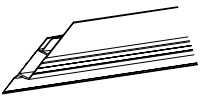

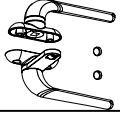
Side Wall



Front Wall





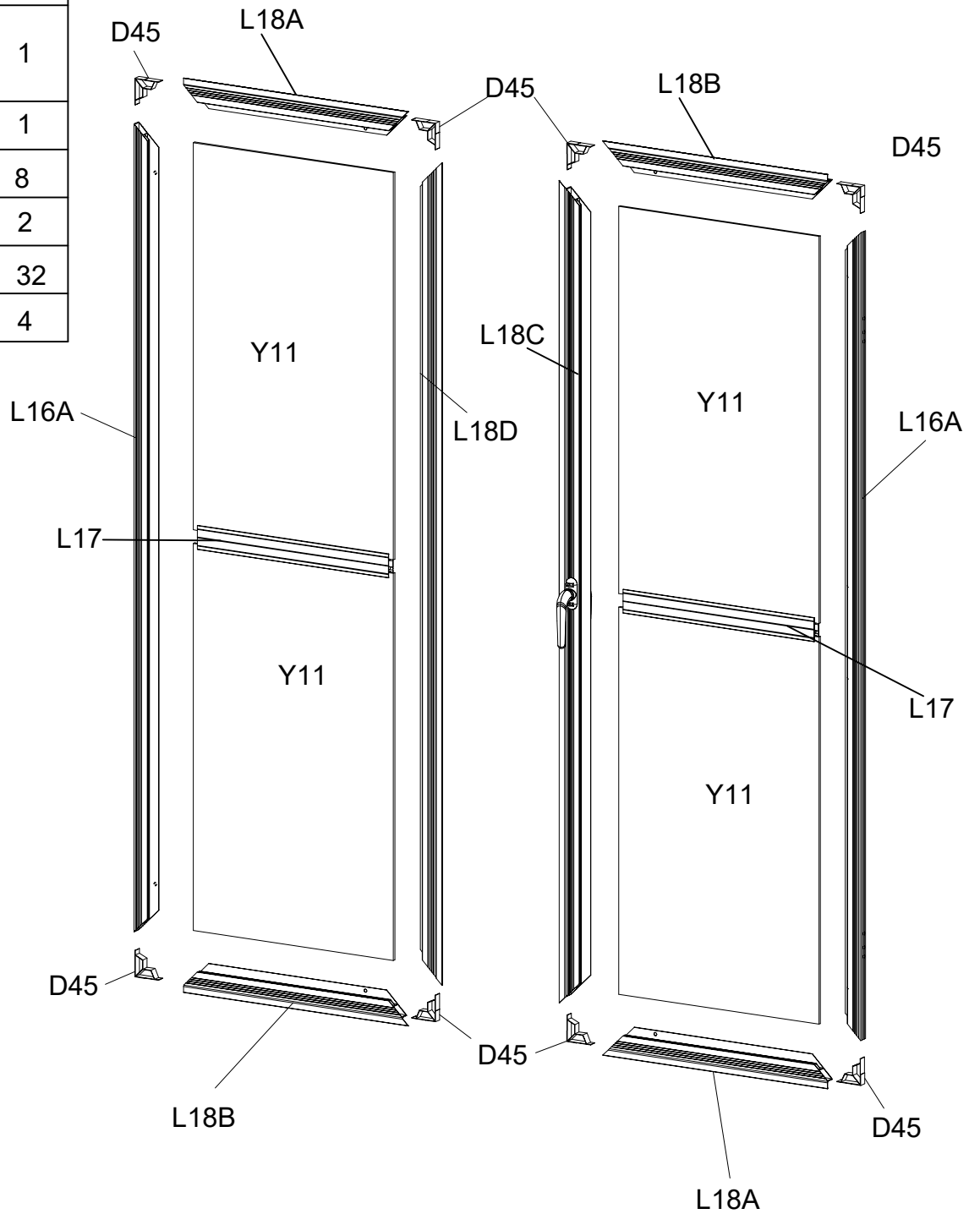

PART	NO	QTY
	L16A	2
	L17	2
	L18A	2
	L18B	2
	L18C	2
	L18D	1
	D45	8
	H152	1
	D47	1
	S26	8
	M5X12	
	S76	2
	M4X32	
	Z08	32
	M4.2X16	
	Y11	4

Exploded View

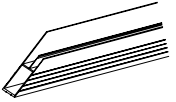
Left Door

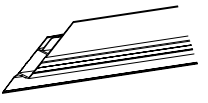
Right Door



PART	NO	QTY
	L16A	1
	L17	1
	L18A	1
	L18B	1
	L18D	1
	D45	4
	S26	4
	M5X12	
	Z08	16
	M4.2X16	
	Y11	2

Left Door

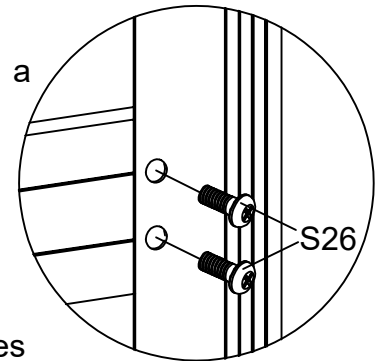
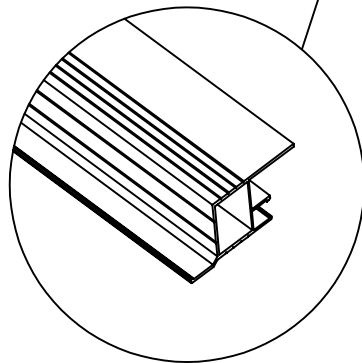
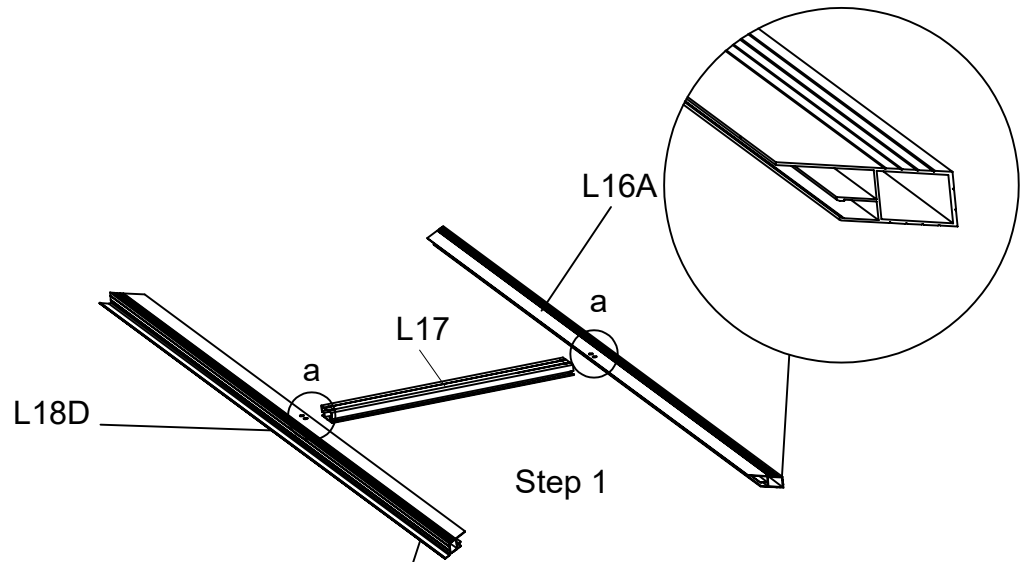

! Attention: Check the direction of the accessories

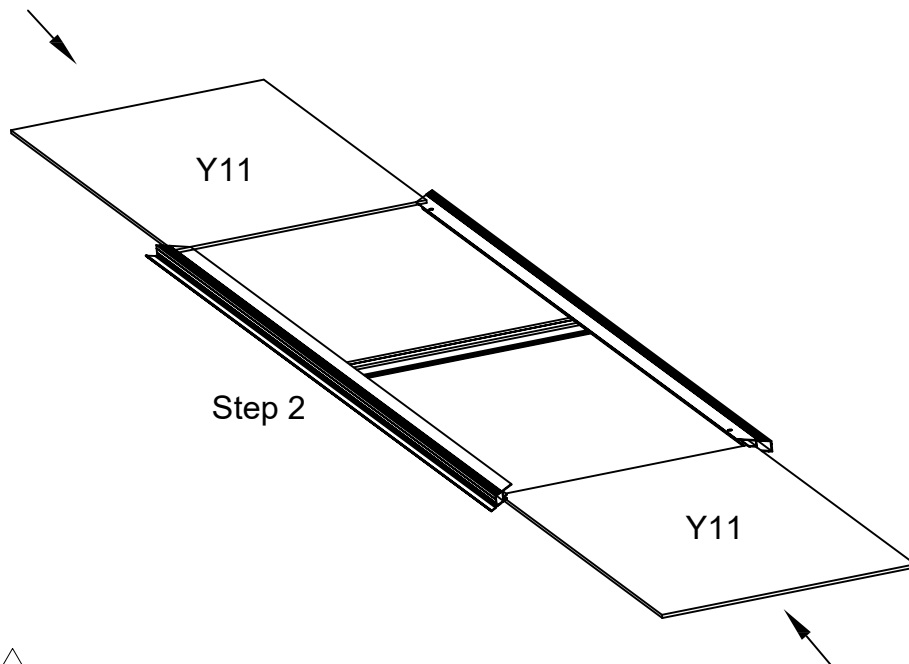

! Attention: Remove the protective films from both sides of each polycarbonate panel, before inserting into aluminum channels. Ensure the milky white film faces towards the Sun.

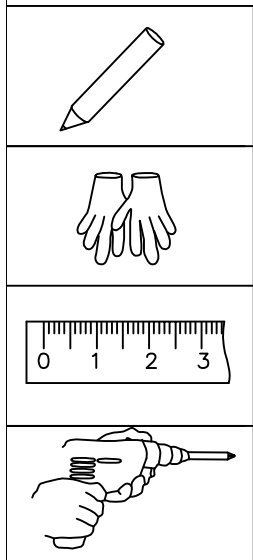

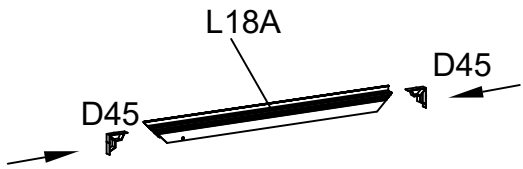



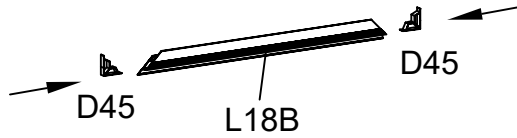



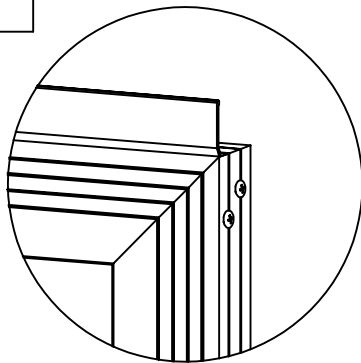
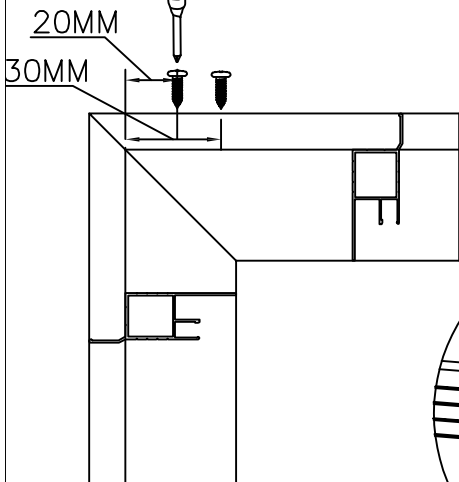
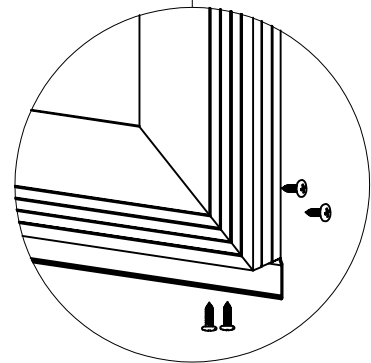
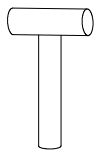
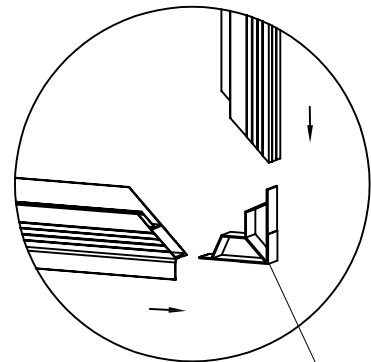
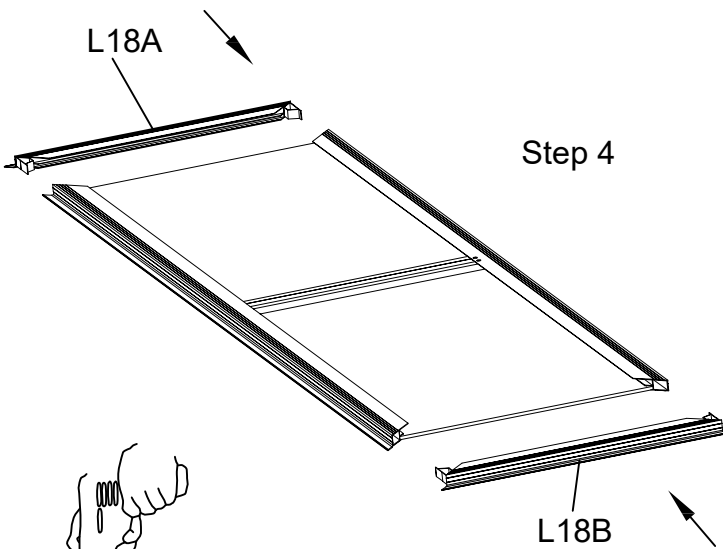

Step 3

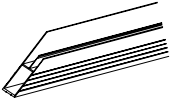

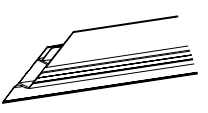
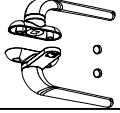
Attention! When installing the D45, you need to use a rubber mallet to lightly tap the snap into.



Insert Connector D45 into each end of frame profiles L16B & L18A & L18B & L18D, and then fix them with screws Z08. fixing with screws, and make sure there is no gaps between each profile.

PART	NO	QTY
	L16A	1
	L17	1
	L18A	1
	L18B	1
	L18C	1
	H152	1
	D45	4
	D47	1
	S26	4
	M5X12	
	S76	2
	M4X32	
	Z08	16
	M4.2X16	
	Y11	2

Right Door

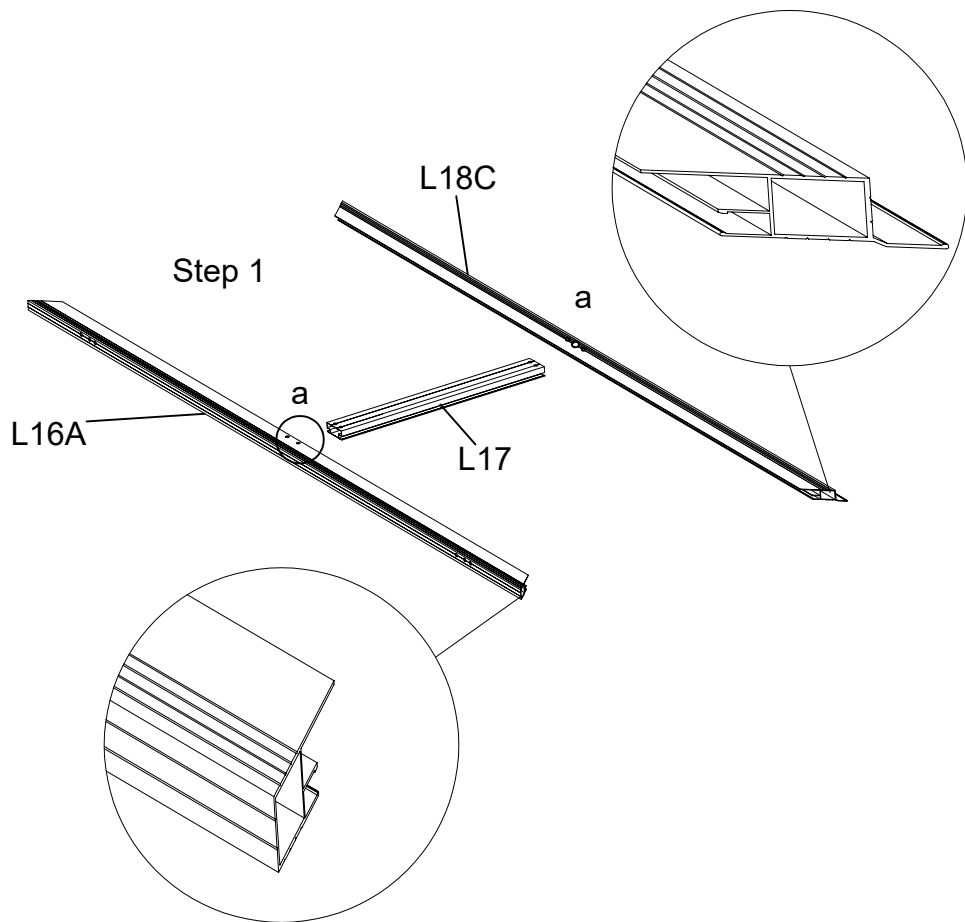

! Attention: Check the direction of the accessories

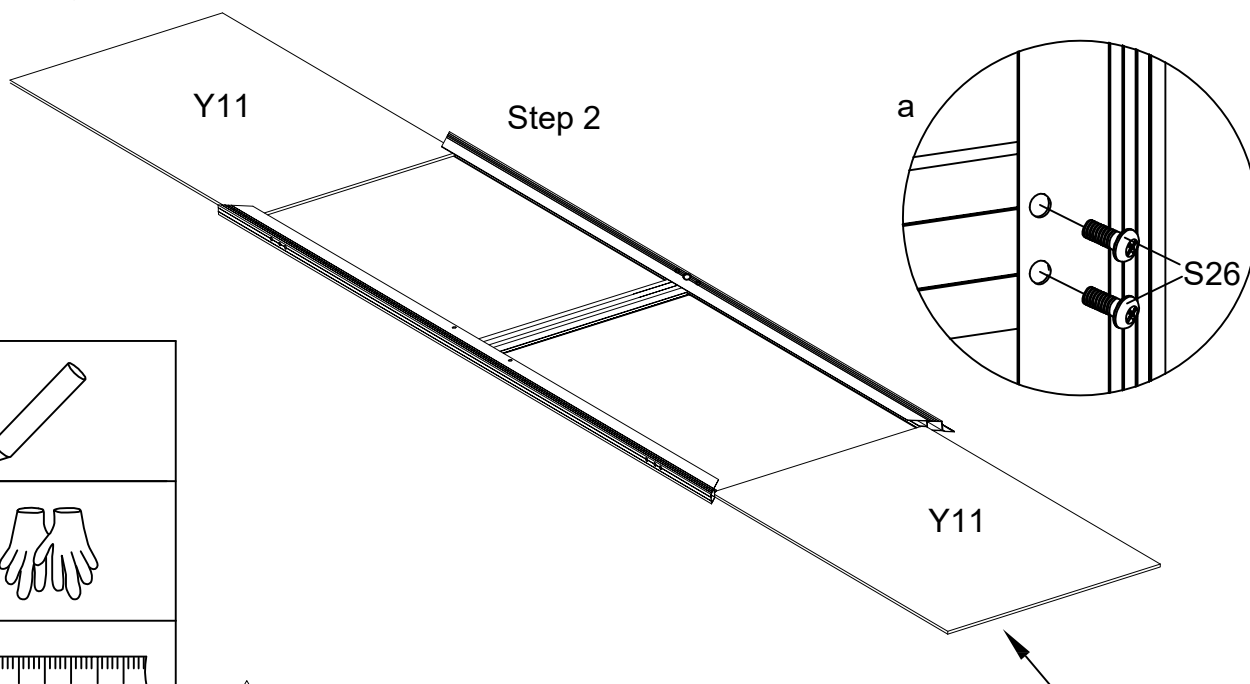

! Attention: Remove the protective films from both sides of each polycarbonate panel, before inserting into aluminum channels. Ensure the milky white film faces towards the Sun.

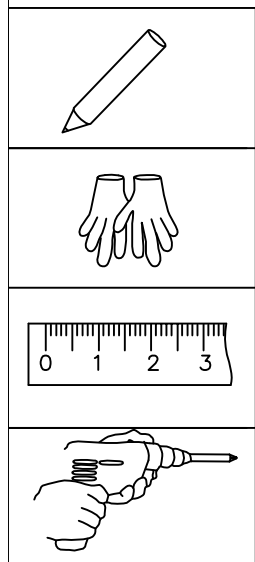

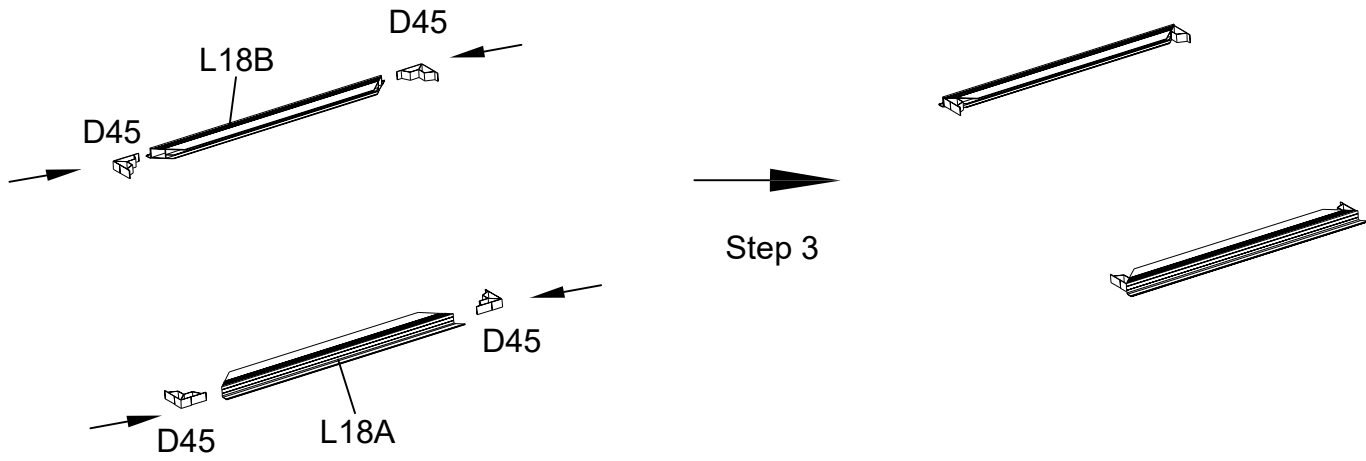

Attention! When installing the D45, you need to use a rubber mallet to lightly tap the snap into.

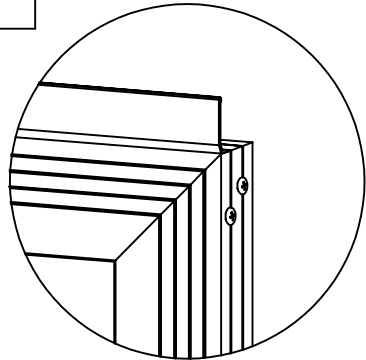
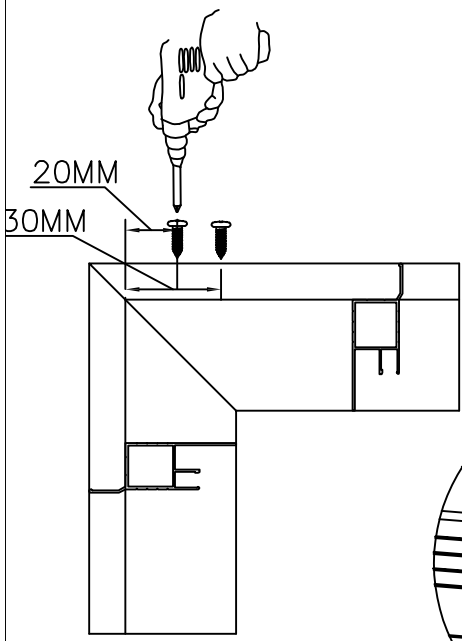
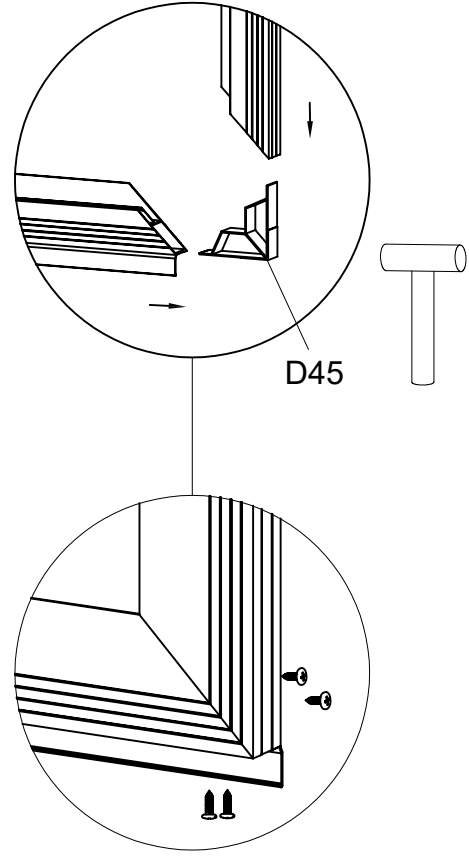
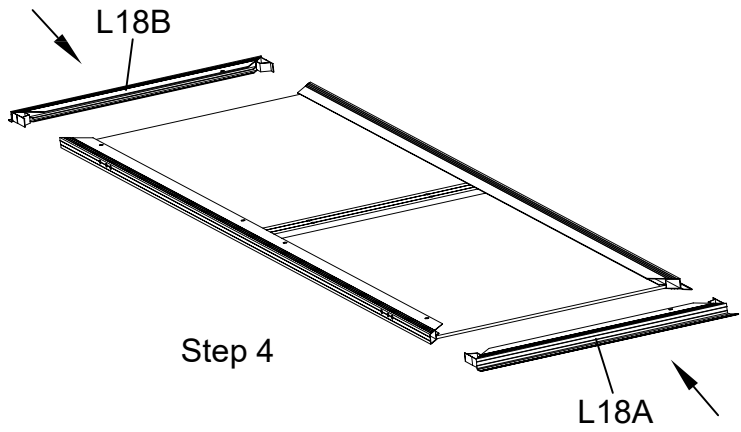

Insert Connector D45 into each end of frame profiles L16B & L18A & L18B & L18D, and then fix them with screws Z08. fixing with screws, and make sure there is no gaps between each profile.

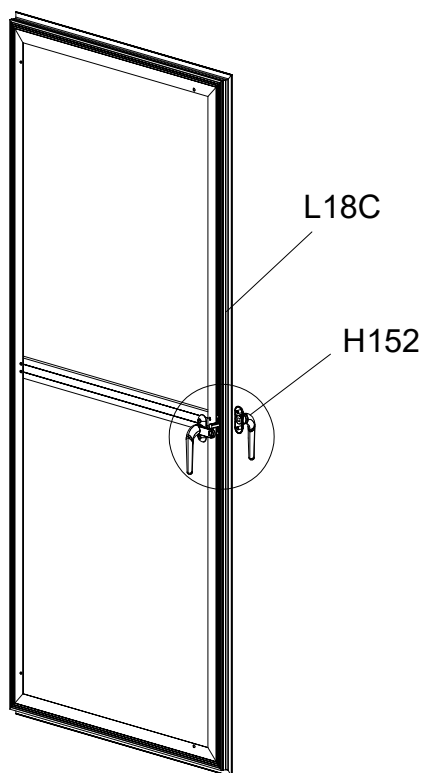





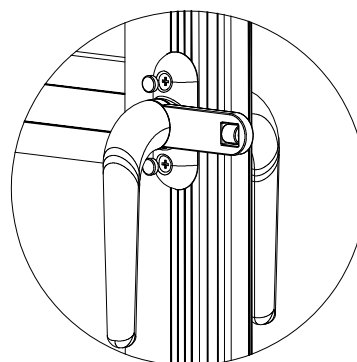
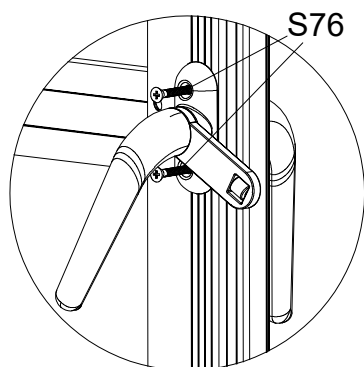
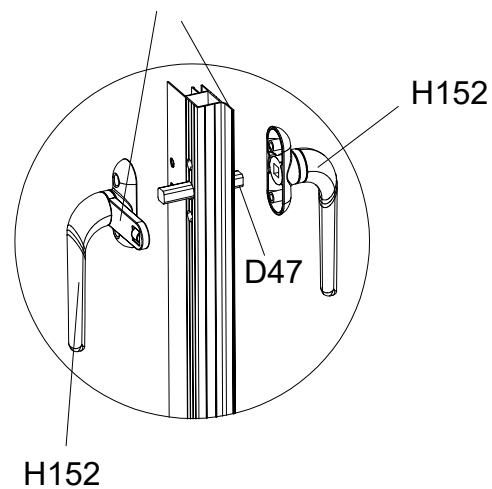

Pay attention to the installation direction

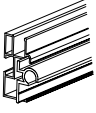
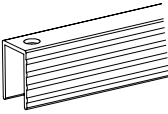
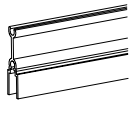
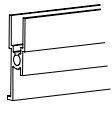
Install H152 after installing the door, when installing, pay attention to the H152 long end toward the door edge, H42 square hole aligned with the square column D47 while inserting, placed in the right position and then fixed with S76 , and finally installed on the decorative cover







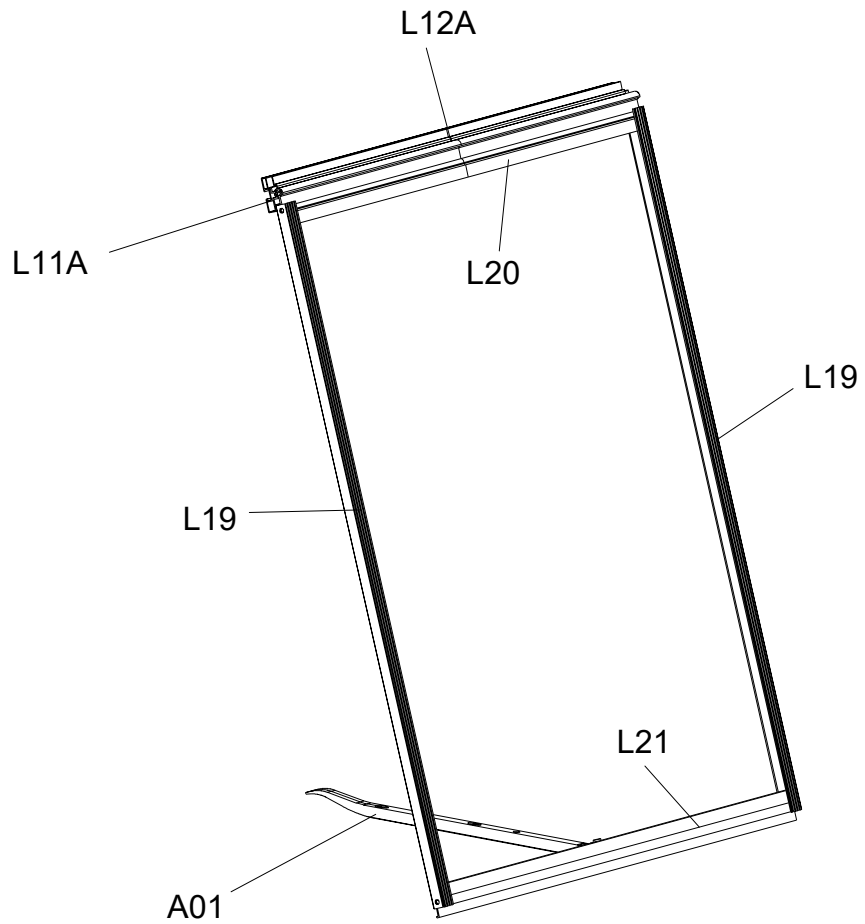

Exploded View

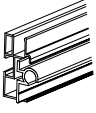
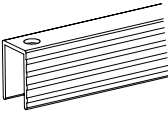
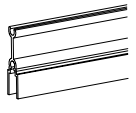
PART	NO.	QTY.
	L11A	2
	L12A	2
	L19	4
	L20	2
	L21	2
	Y10	2
	A01	2
	Z02 Ø4X16D	12
	Z04 Ø4X8	4
	Z08 M4.2X16	4

Window X 2



PART	NO.	QTY.
	L11A	1
	L12A	1
	L19	2
	L20	1
	L21	1

Part	NO.	QTY.
	Y10	1
	A01	1
	Z02	6
	Ø4X16D	
	Z04	2
	Ø4X8	

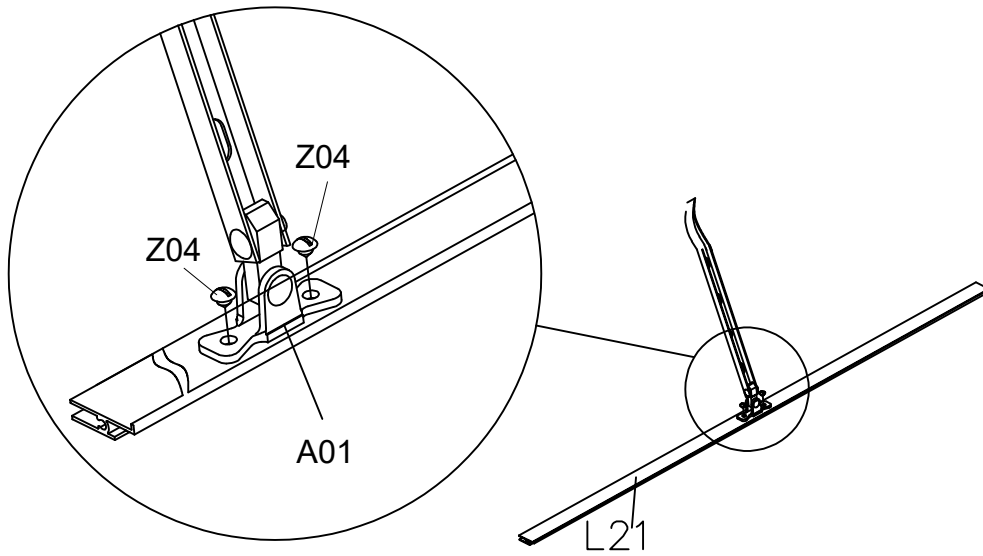

Step 1

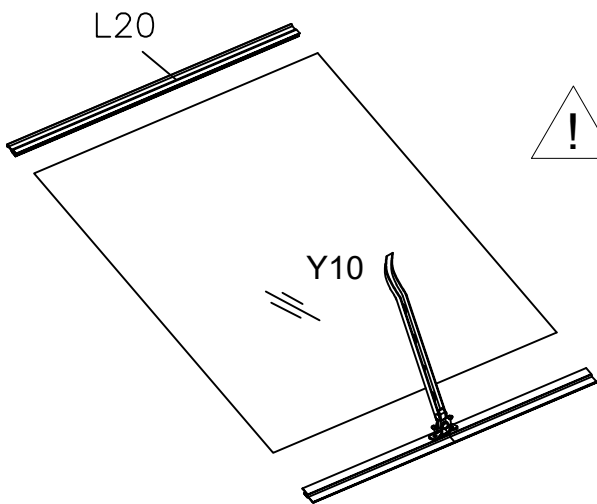





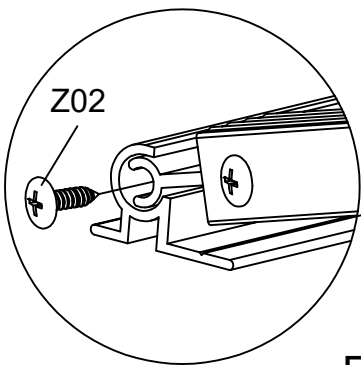
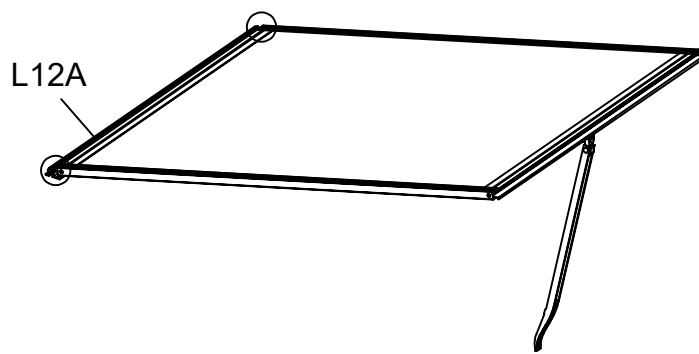
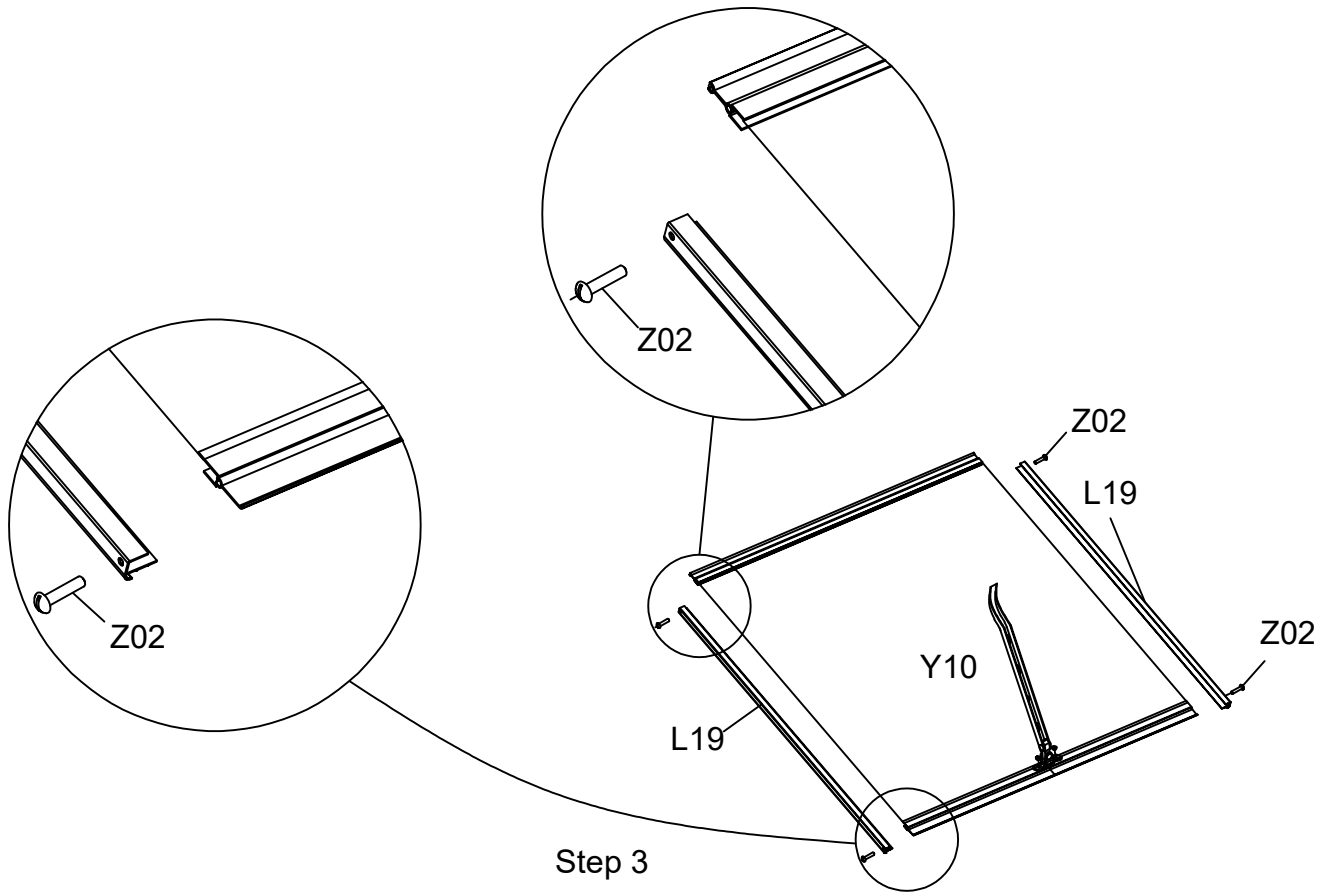

Step 2

! Attention: Remove the protective films from both sides of each polycarbonate panel, before inserting into aluminum channels. Ensure the milky white film faces towards the Sun.



Four windows are standard

PART	NO	QTY
	B2	6
	A2	2
	D306	4
	D307	3
	S01 M6X12	28
	M01 M6	28

Base Assembly

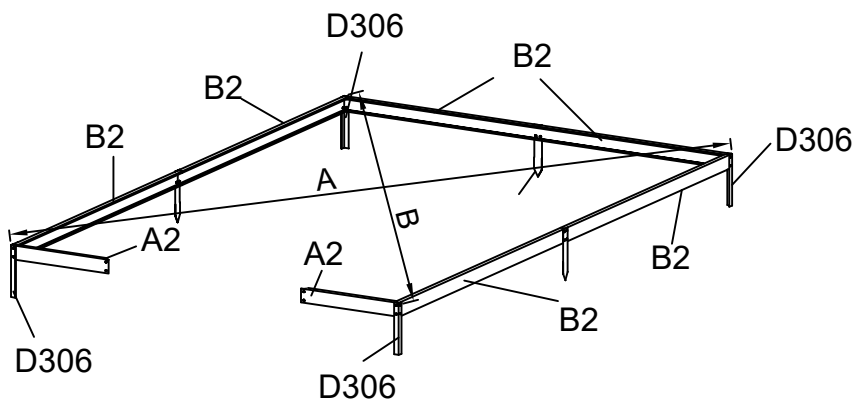
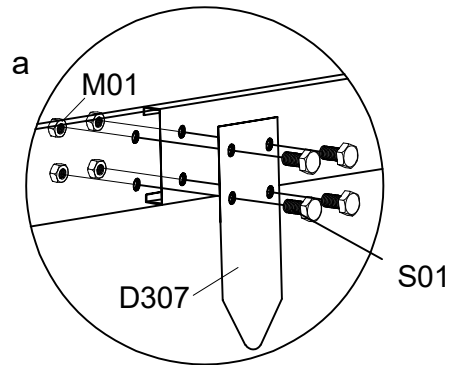
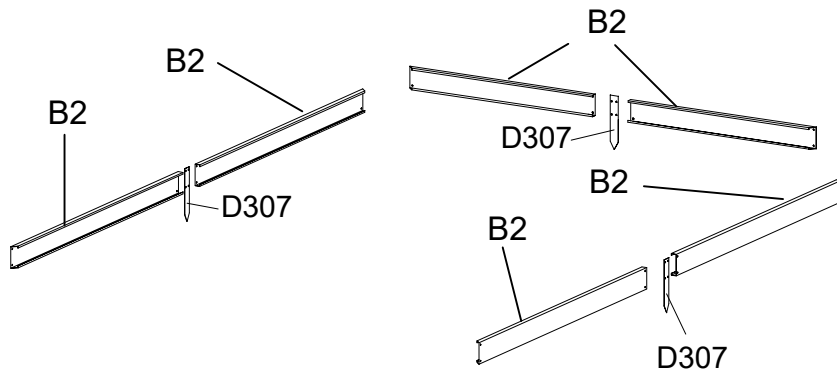

Attention! D306 and D307 must be inserted into the soil or installed in reverse!

$$\textcircled{A} = \textcircled{B}$$

Fix the base before assembly the greenhouse. This is the way to fix the base.

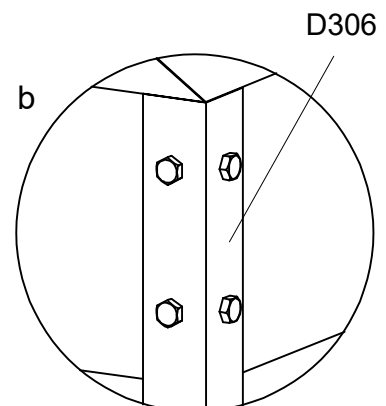



Base Assembly

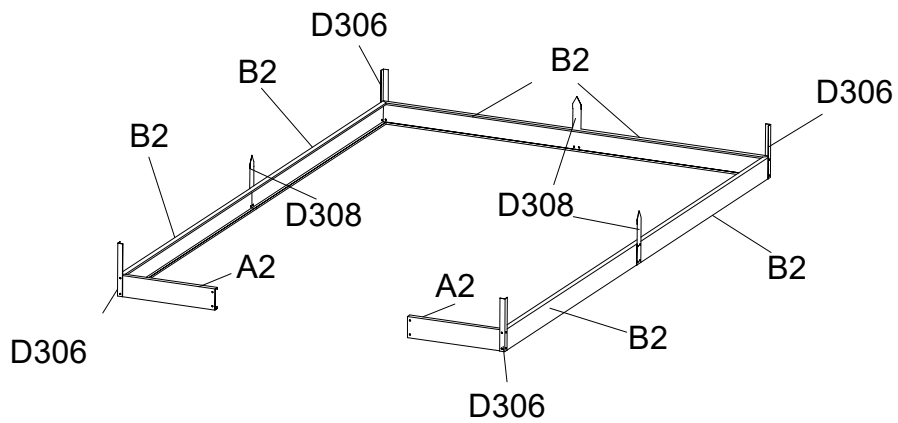

! Attention: Turn over the steel plinths D306 & D308 to complete the base installation as shown below, when the greenhouse is NOT inserted and secured into the soft soil.



PART	NO	QTY
	D114	16
	S69 M6X60	16

Base Assembly

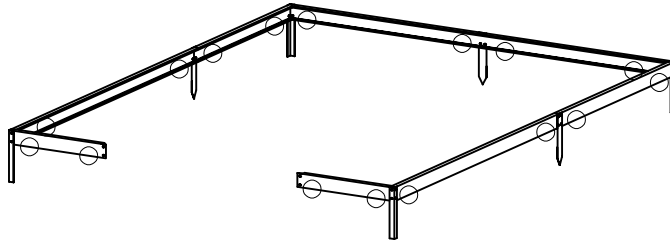

1. Fix the base anchor clip D114 onto each base section with a distance of 5~10CM from each end.
2. Mark the middle of the D114 hole to drill the $\text{Ø}8$ hole, then use S69 to fix the D114 to the ground

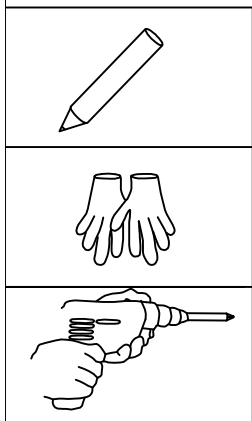
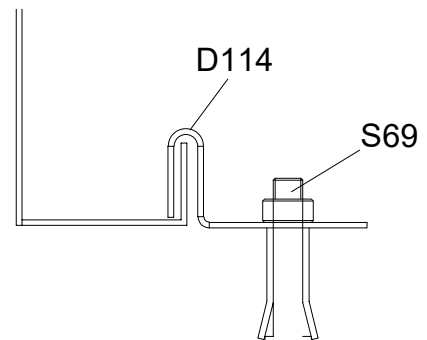
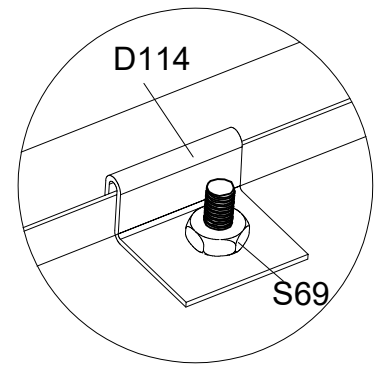
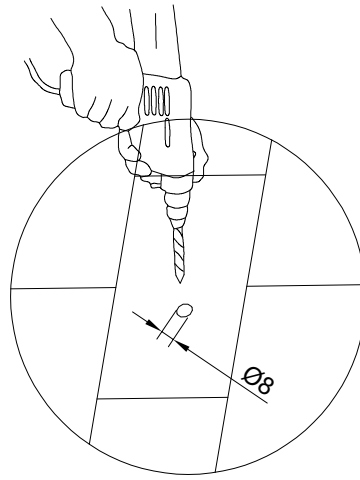
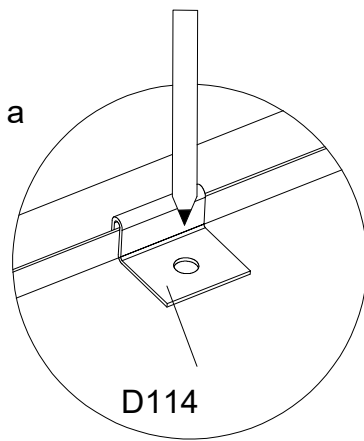
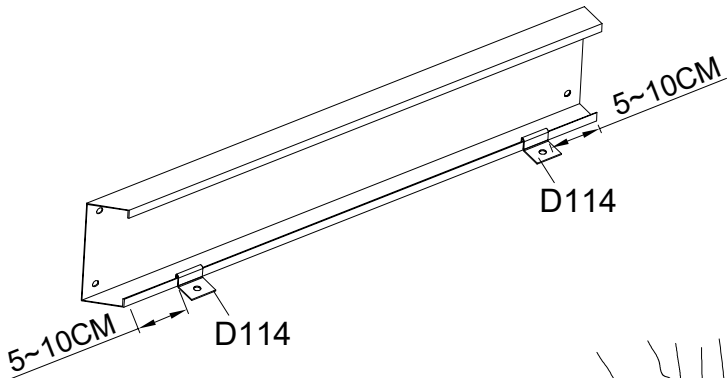

Wall Assembly

PART	NO	QTY
	L01E	1
	L01F	1
	L08B	2
	L10A	2
	L10B	1
	S01 M6X12	4
	M01 M6	4
	Z08 M4.2X16	8

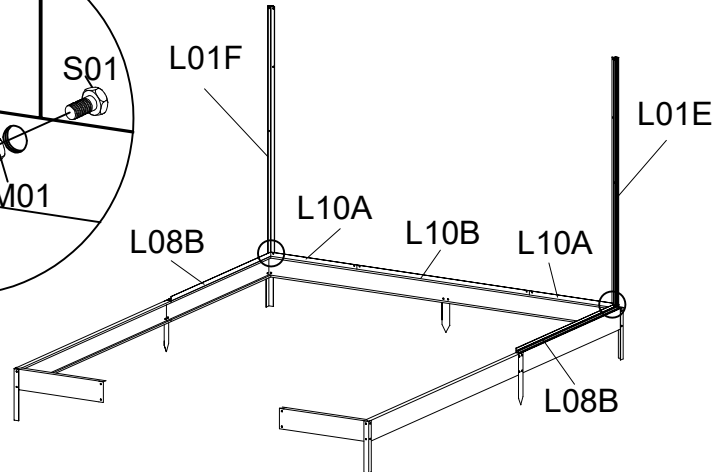
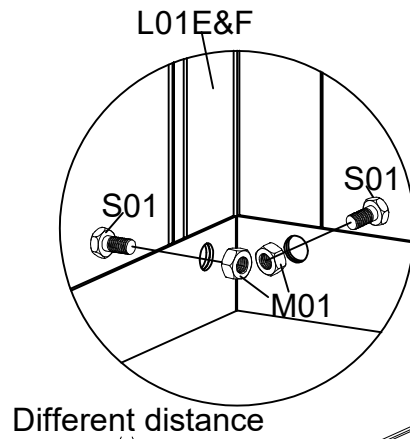

Attention! L01E, L01F holes with different distances should be installed facing upwards.

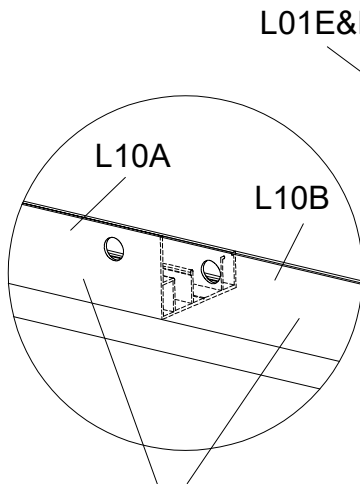



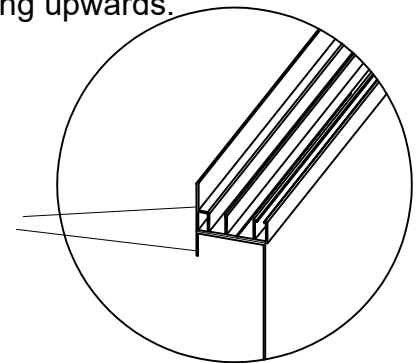

Make sure they line up from inside with the base plinth before fixing them with Z08

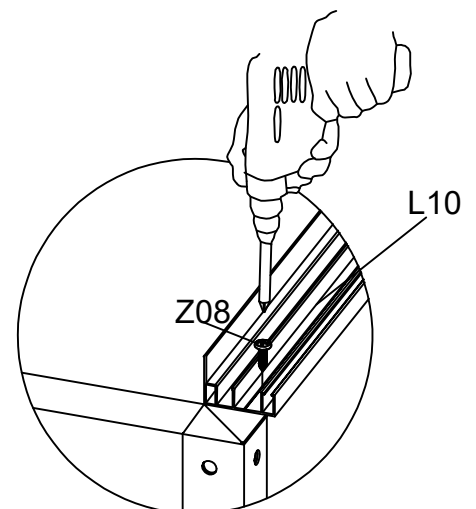
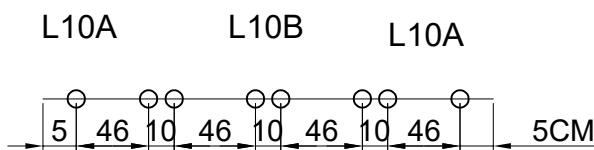
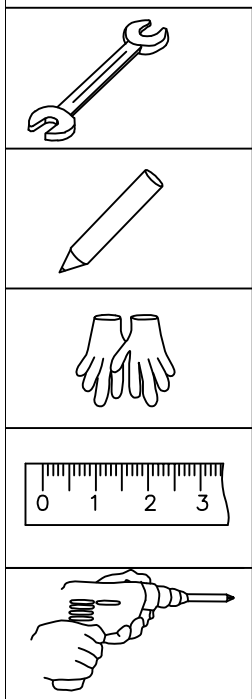

- Place L10A, L10B, L01E, L01F & L08B on the base plinth (B2 & C2), then fix them together using S01 & M01 as shown. Make sure they line up from inside of the base plinth.
- Use a powered screwdriver to fix the self-tapping screws (Z08) through the cills (L10A, L10B & L08B) and base plinth (B2, C2 and A2). The screws should be evenly spaced to ensure a neat appearance. The recommended spacing of the screws is 460mm. You can mark the painted surfaces with a pencil.



PART	NO	QTY
	L23B	2
	L26D	1
	S01 M6X12	6
	M01 M6	6

Wall Assembly

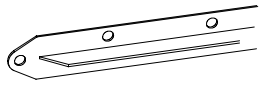
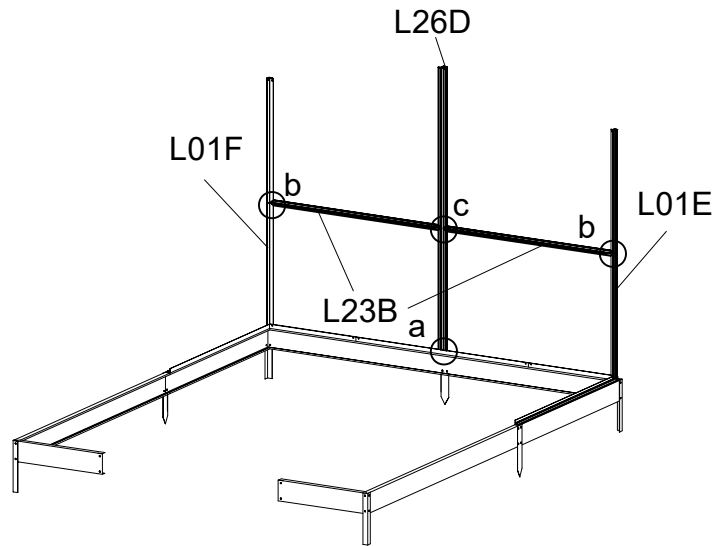



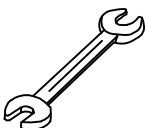
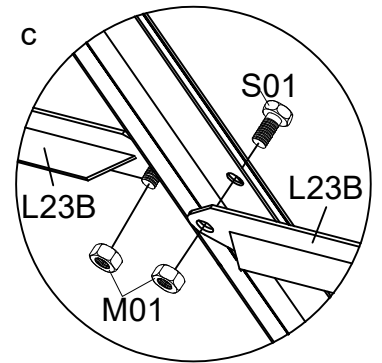
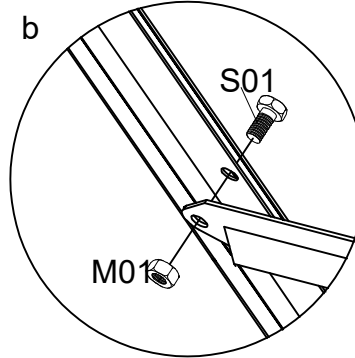
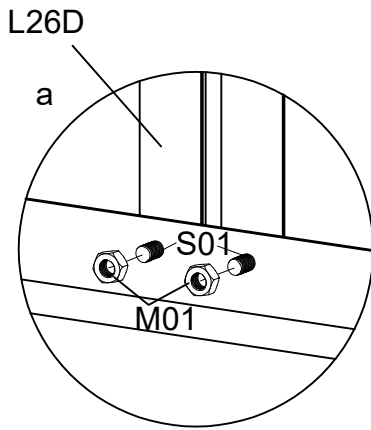

Attention! Put the side with 2 holes of L23B facing upwards.

Fix L26D onto L10B, using S01 & M01.

Fix L23B * 2PCS to L01E, L01F & L26D, using S01 & M01

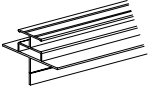
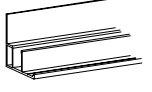

Wall Assembly

PART	NO	QTY
	L03A	2
	L08B	2
	S01 M6X12	4
	M01 M6	4
	Z08 M4.2X16	8

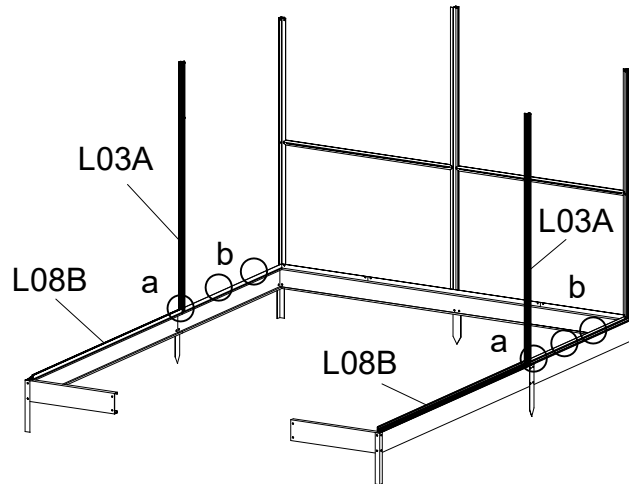

1. Place L08C on the base plinth and fix L03A onto L08C, using S01 & M01.
2. Use a powered screwdriver to fix the self-tapping screws (Z08) through the cills (L08C) and base plinth (C2). The screws should be evenly spaced to ensure a neat appearance. The recommended spacing of the screws is 460mm. You can mark the painted surfaces with a pencil.

Attention! : Install the L03A with the side with the hole facing up!

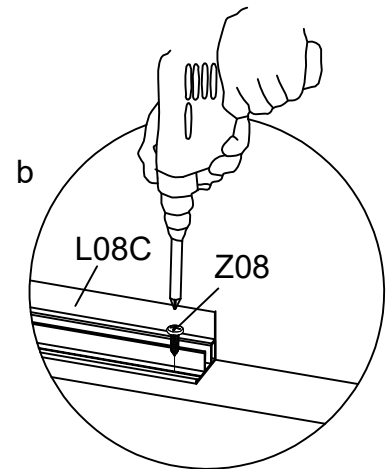
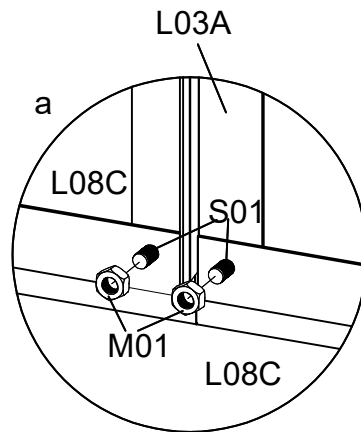
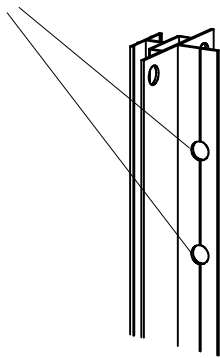

Z08 distances reference

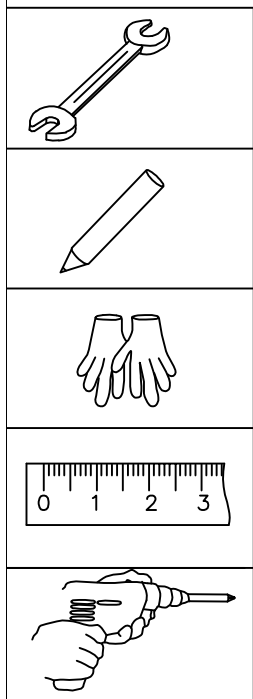
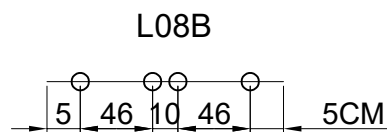

Wall Assembly

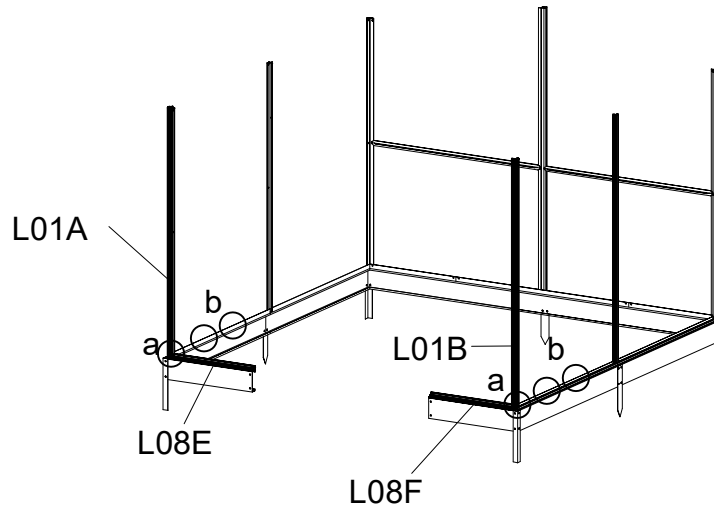

PART	NO	QTY
	L01A	1
	L01B	1
	L08E	1
	L08F	1
	S01 M6X12	4
	M01 M6	4
	Z08 M4.2X16	12

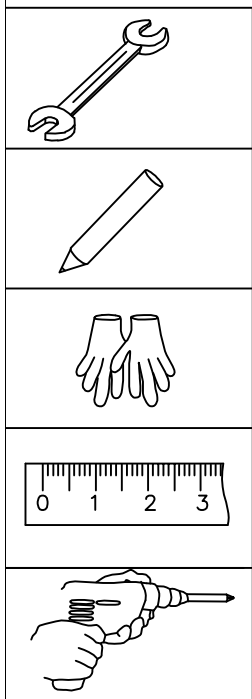
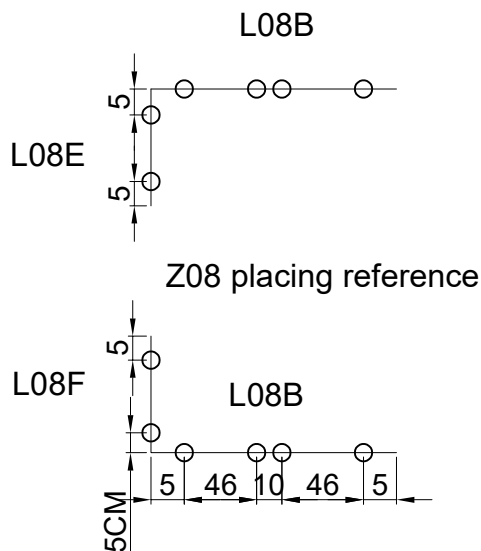
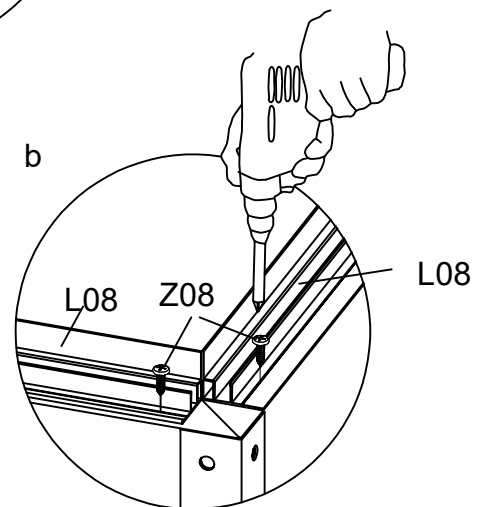
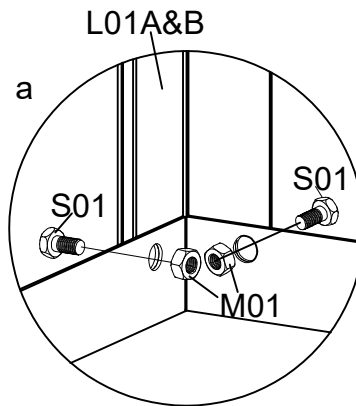

1. Place L08E & L08F on the base plinth and fix L01A & L01B onto L08C & L08E/L08F, using S01 & M01.
2. Use a powered screwdriver to fix the self-tapping screws (Z08) through the cills (L08C, L08E & L08F) and base plinth (A2 & C2). The screws should be evenly spaced to ensure a neat appearance. The recommended spacing of the screws is 460mm. You can mark the painted surfaces with a pencil.



Wall Assembly



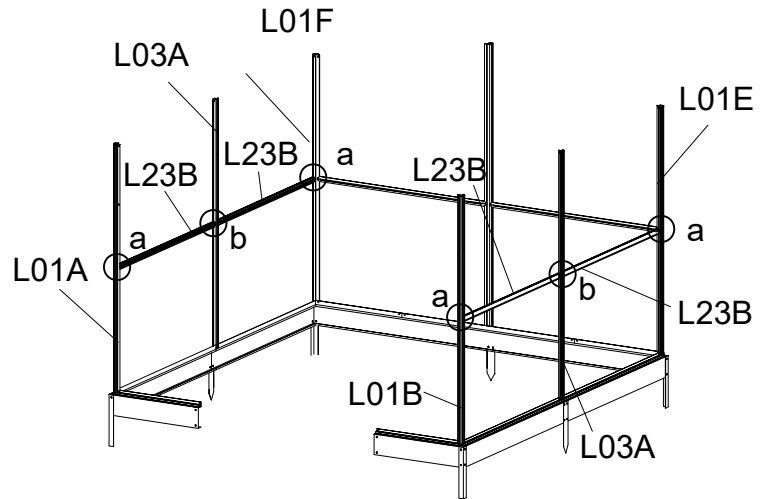

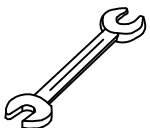
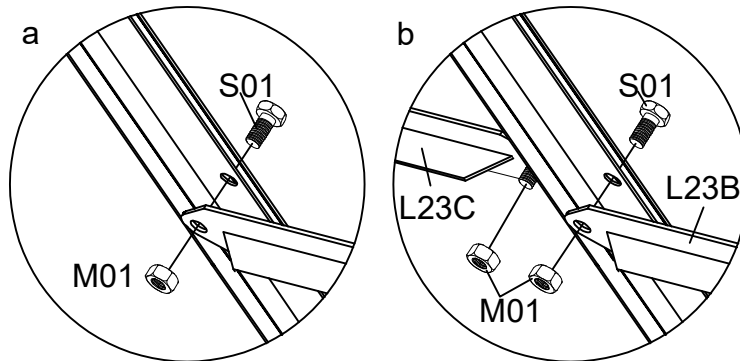

PART	NO	QTY
	L23B	4
	S01 M6X12	8
	M01 M6	8



Fix L23B & L23C onto L01A, L01B, L03A, L01E & L01F, using S01 & M01

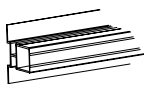

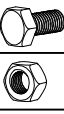
Wall Assembly

PART	NO	QTY
	L10C	1
	L23G	2
	L26A	1
	L26B	1
	D317	2
	S01 M6X12	12
	M01 M6	12
	S26 M6X12	4

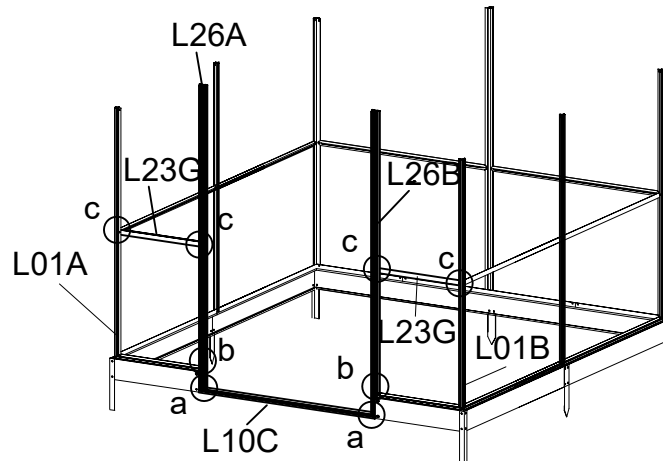

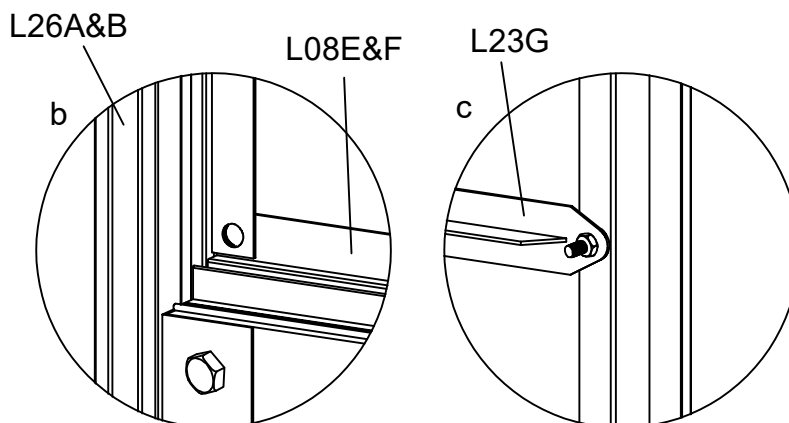
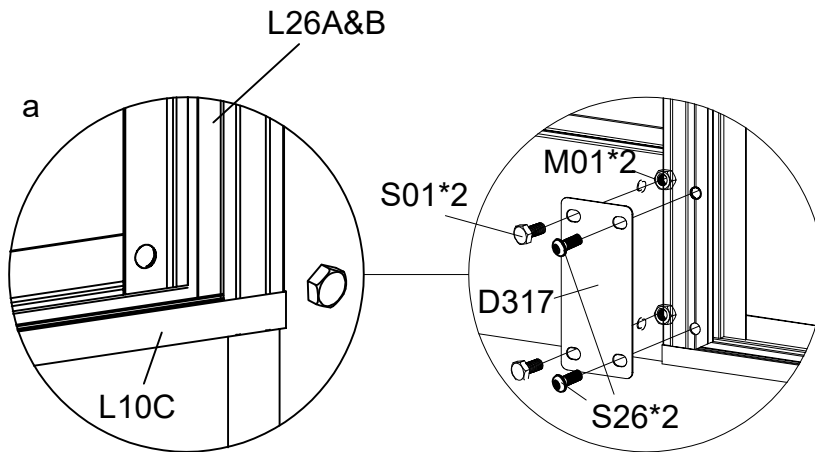

Fix L26A onto L08E,
L26B onto L08F using S01 & M01

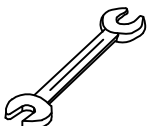

Fix 23G * 2PCS onto L01A & L26A
/L01B & L26B, using S01 & M01.

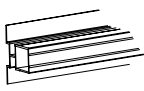

Wall Assembly

PART	NO	QTY
	L07B	4
	L26C	2
	S01 M6X12	16
	M01 M6	16

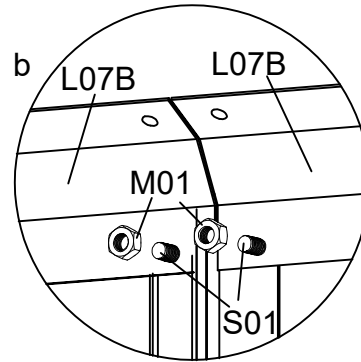
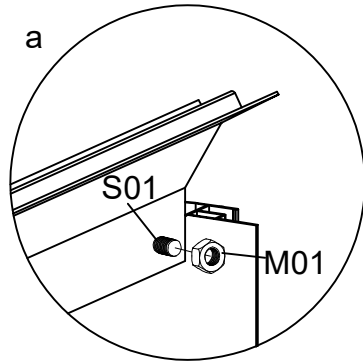
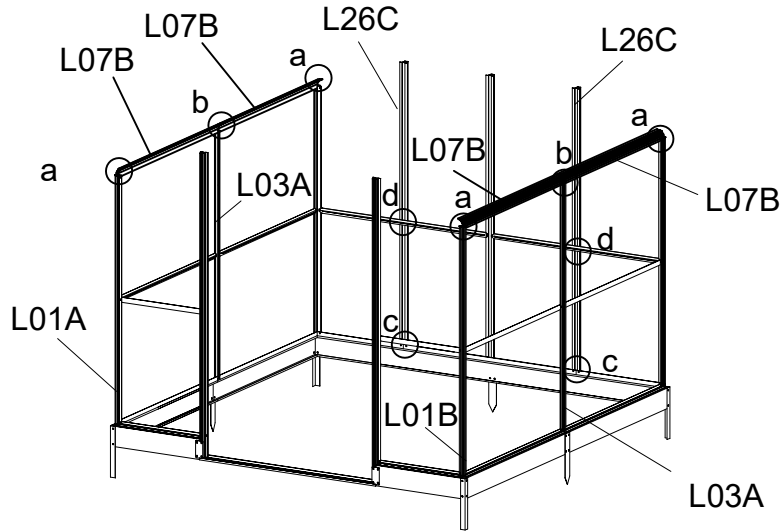

Fix L07B & L07C onto L01A, L03A & L01F and L01B, L03A & L01E, using S01 & M01

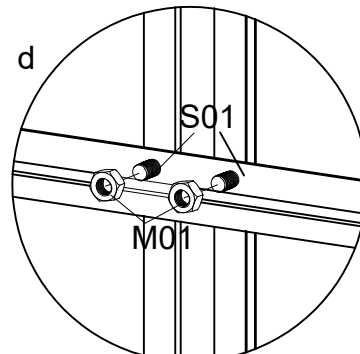
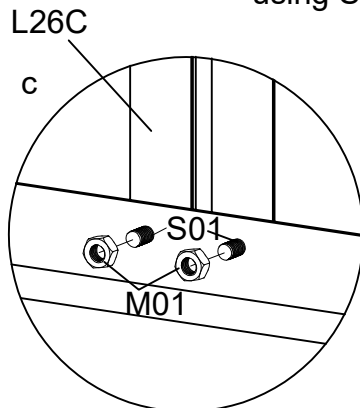

Fix L26C * 2PCS onto L10A, L10B & L23B using S01 & M01

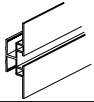

Wall Assembly

PART	NO	QTY
	L02A	4
	S01 M6X12	20
	M01 M6	20

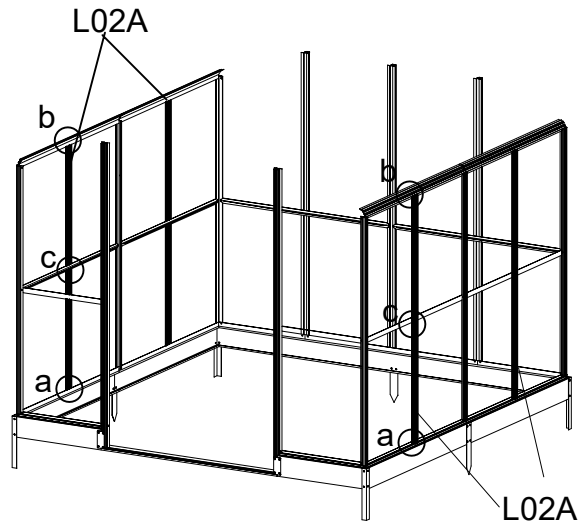



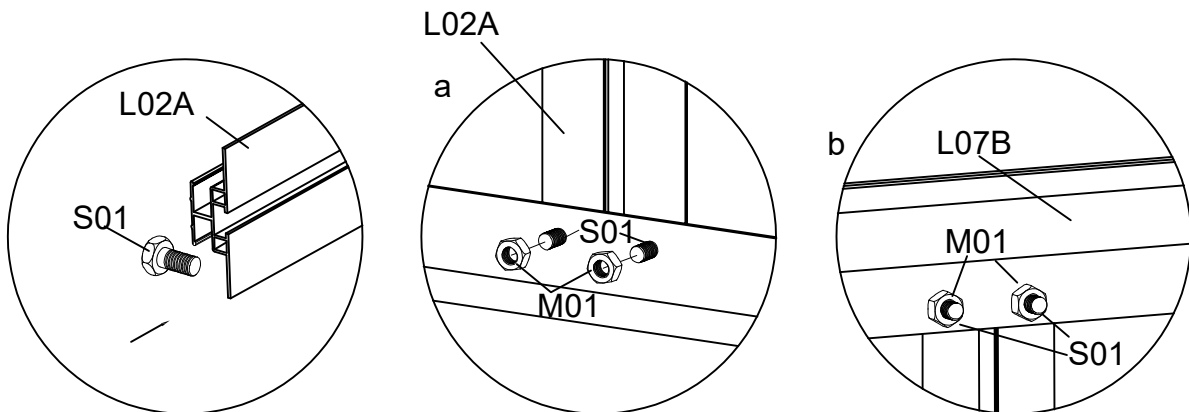

Fix L02A (8pcs) to L08B and L07C using S01 & M01.

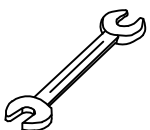
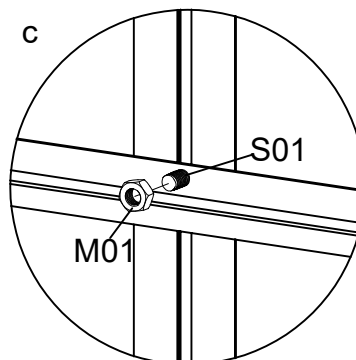

Slide a bolts (S01) into each L02A bolt channel. One is to fix L23C



Wall Assembly

PART	NO	QTY
	L02D	6
	Y2	6
	S01 M6X12	22
	M01 M6	22

Put the panels into positions

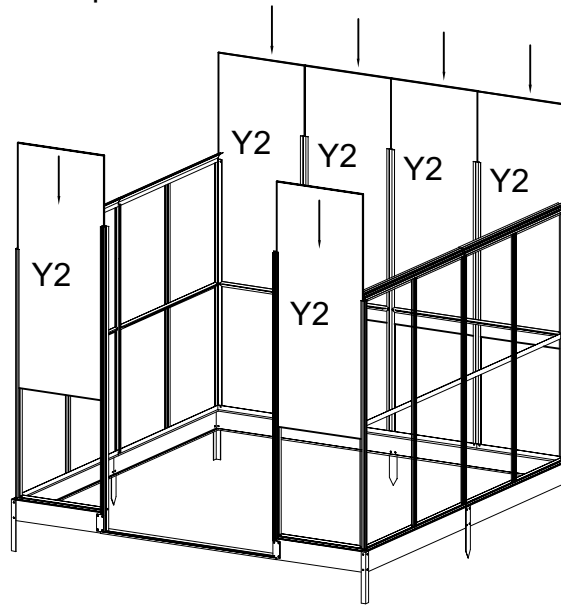

! Attention: Remove the protective films from both sides of each polycarbonate panel, before inserting into aluminum channels. Ensure the milky white film faces towards the Sun.

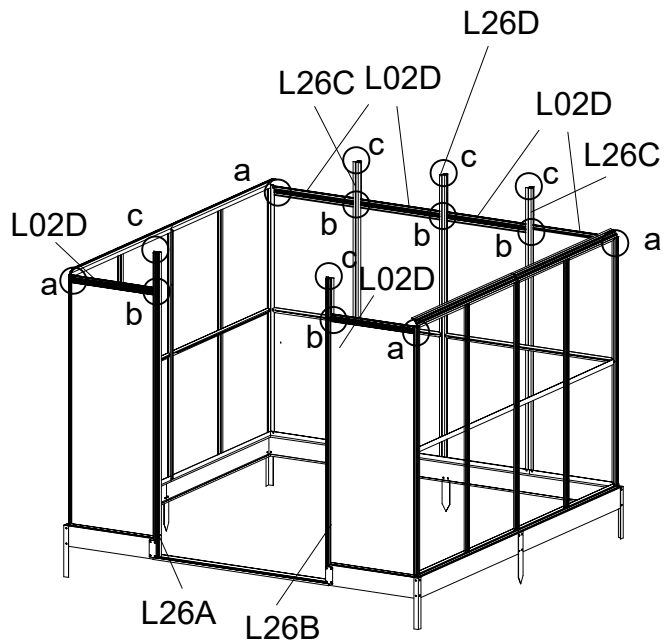

Fix L02D * 6PCS as shown, using S01 & M01

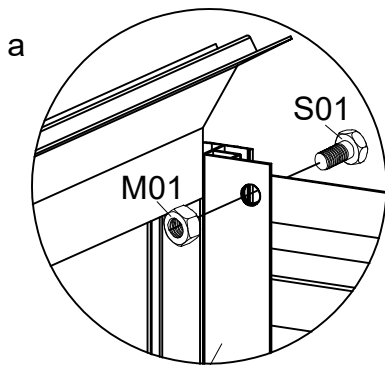

L01A&B&E&F

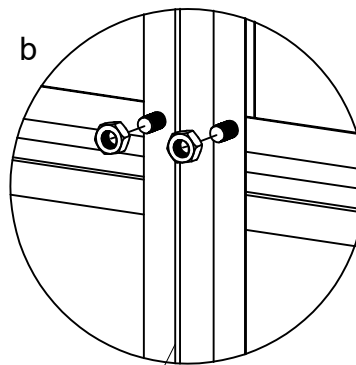

L26A&B&C&D

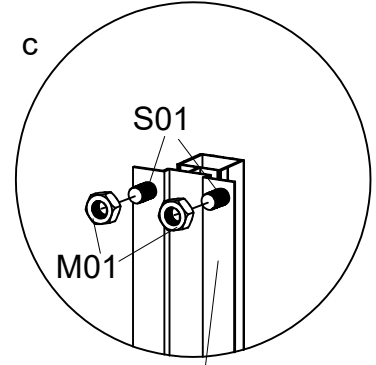







L26A&B&C&D

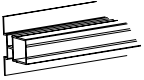

! Attention:

Please pre-load S01 & M01 on L26A, L26B, L26C and L26D before putting panels Y1, Y4 & Y9 into position.



PART	NO	QTY
	L26G	1
	L26H	1
	Y1	2
	Y4	2
	Y6	8
	Y9	2
	S01 M6X12	8
	M01 M6	8

Put the panels into positions

Wall Assembly

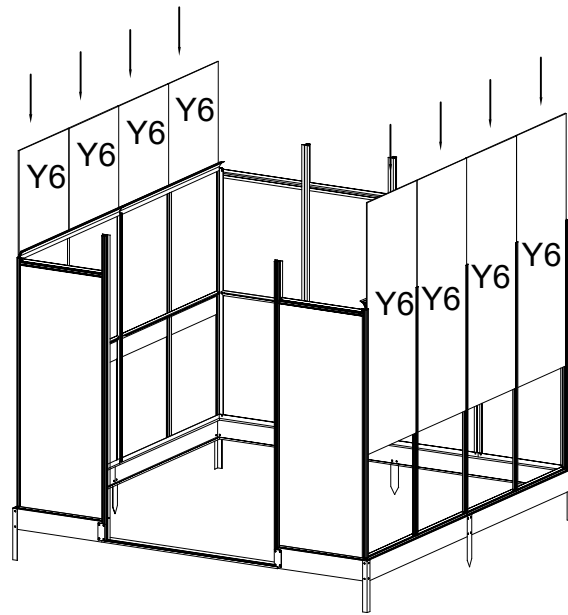

Put the panels Y1, Y4 and Y9 into positions.

 **!Attention:**



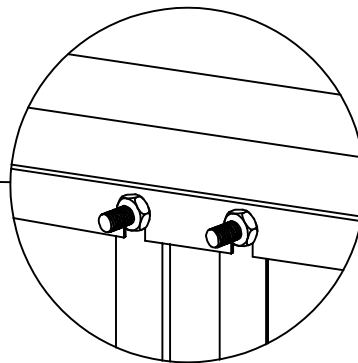
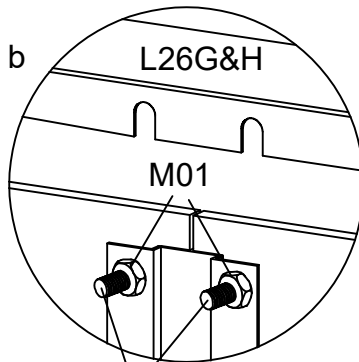
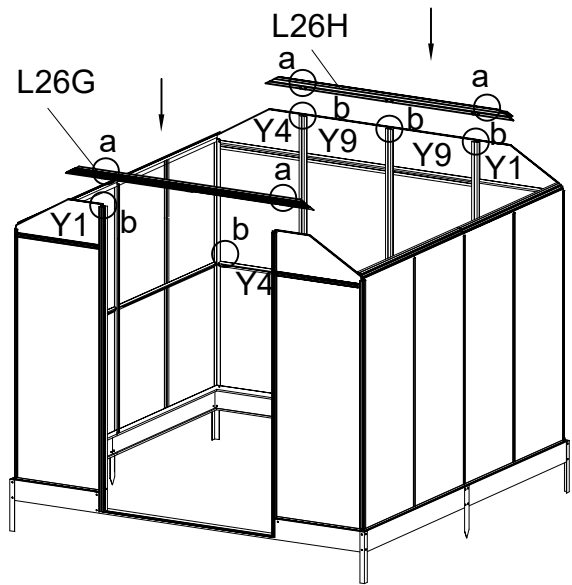
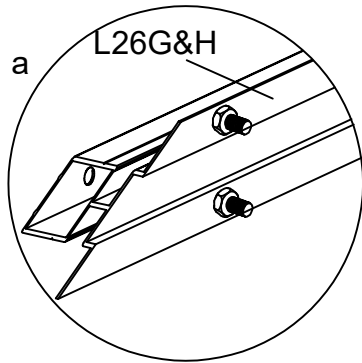

Please pre-load S01 & M01 on L26G & L26H before putting panels Y1, Y4 & Y9 into position.

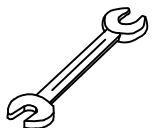

Loose the nuts M01 on L26A, L26B, L26C & L26D to allow L26G & L26H fitted in.
After the screws are inserted into the U-shaped opening, it is necessary to adjust the structure and lock it.

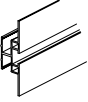

Top Assembly

PART	NO	QTY
	L02C	2
	Y3	2
	Y8	2
	S01 M6X12	6
	M01 M6	4

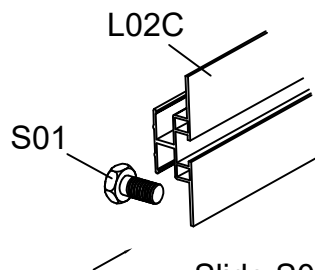
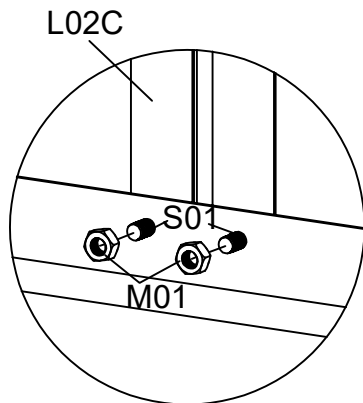
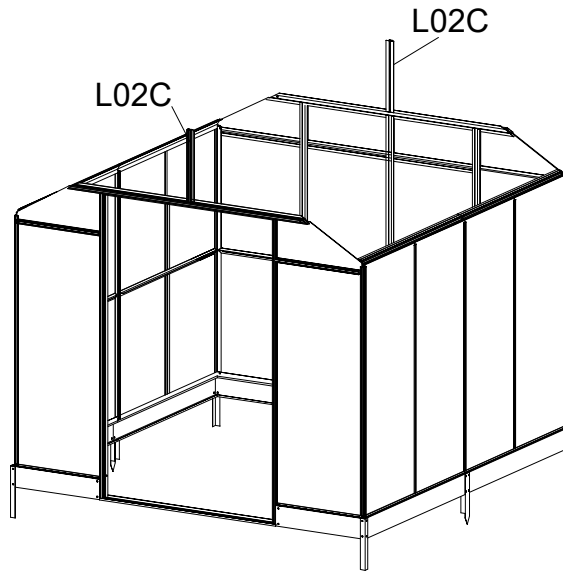

Slide S01 into the channel of L02C

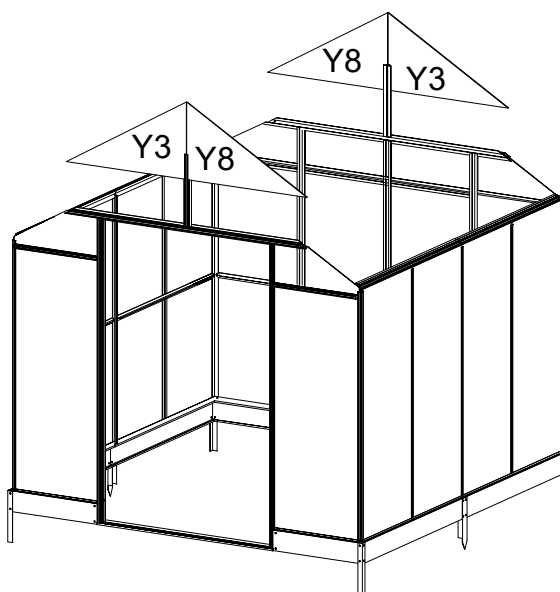





! Attention: Remove the protective films from both sides of each polycarbonate panel, before inserting into aluminum channels. Ensure the milky white film faces towards the Sun.

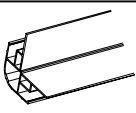

Put the glazing panels Y3 & Y8 into positions.

Top Assembly

PART	NO	QTY
	L01C	2
	L01D	2
	D17	2
	D309	4
	S01 M6X12	20
	M01 M6	22

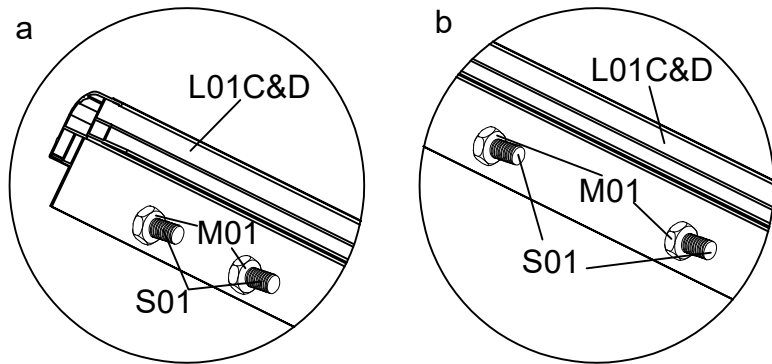
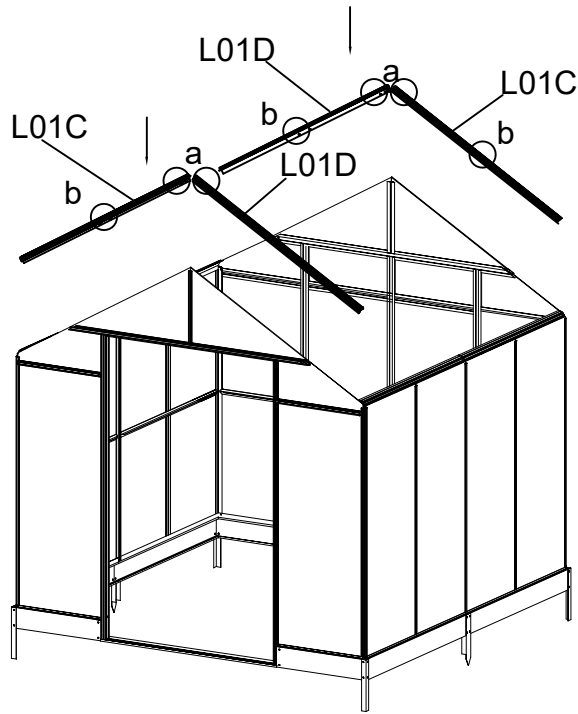

 1. Preload S01 & M01 on L01C and L01D before fixing them to L01A/L01B. See figure a & b.



Top Assembly

If the holes are not aligned, it may be due to uneven foundation, adjust the foundation and frame to solve the problem

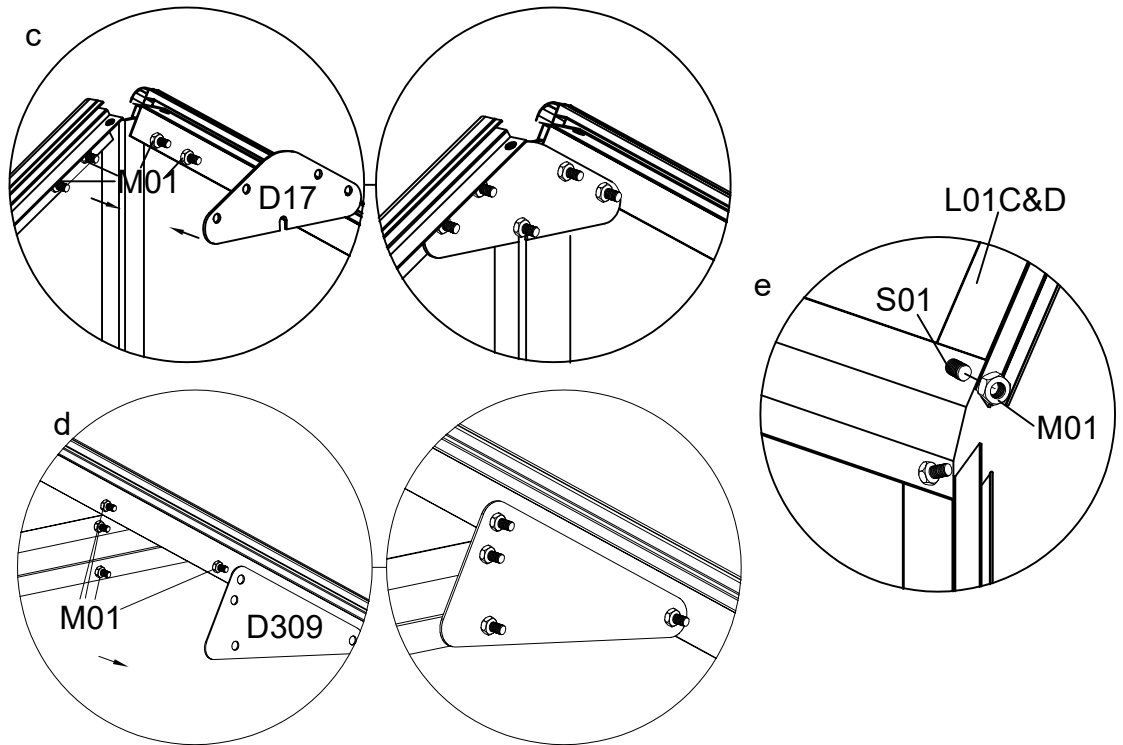
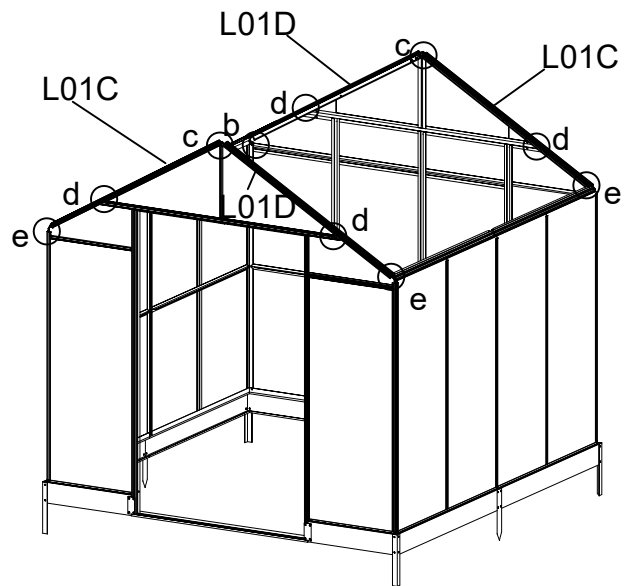





2. Bolt L01C and L01D with plate D17, using S01 & M01 preloaded. And then fix them to L02C, using S01 & M01.

3. Fix L01C & L01D to L26G & L26H with the plate D309, using the S01 and M01 preloaded above.

4. Fix L01C & L01D to L01A & L01B, using S01 & M01.

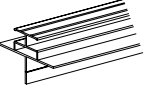

Top Assembly

PART	NO	QTY
	L03B	2
	L23E	3
	D17	3
	S01 M6X12	22
	M01 M6	22

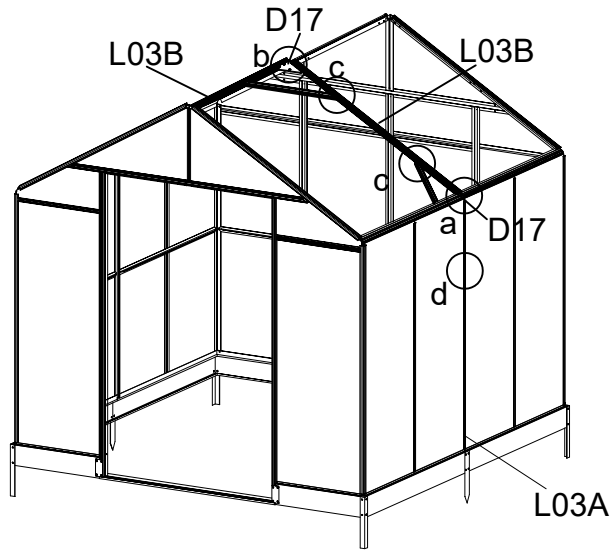

Fix plates D17 to L03A & L03B using S01 & M01.

Fix glazing bars L03B to the eaves and the ridge profiles using S01 & M01

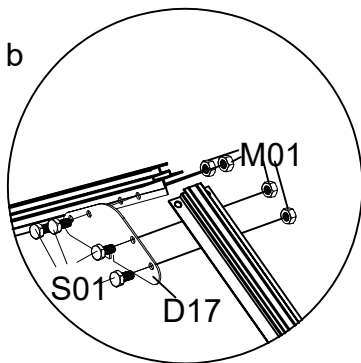
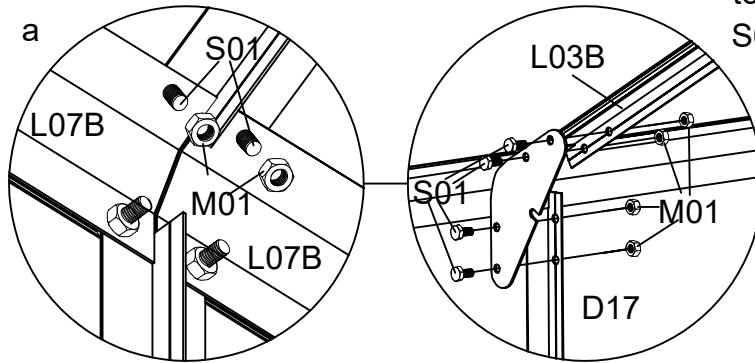

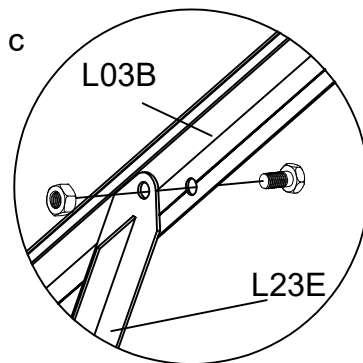

Fix plates D17 to the two L03B using S01 & M01.

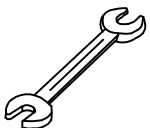
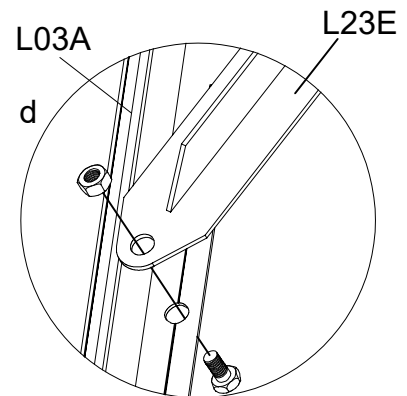

Fix L23E to L03A and L03B using S01 & M01.

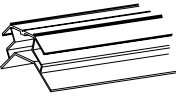

Top Assembly

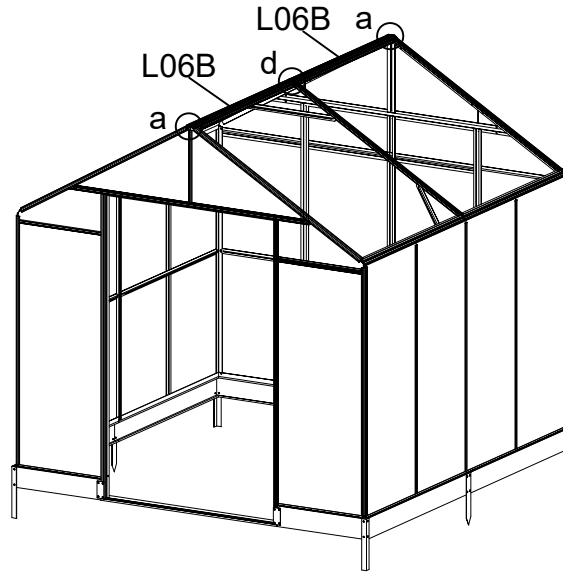

PART	NO	QTY
	L06B	2
	S01 M6X12	8
	M01 M6	8

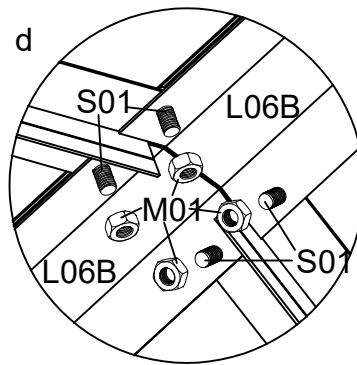
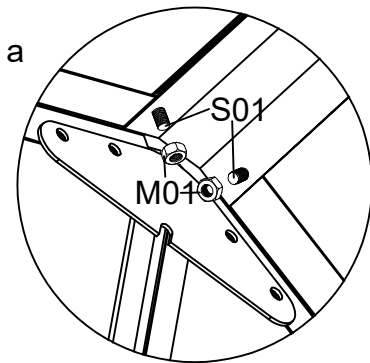

Bolt the ridge L06B to L01C, L01D and L03B, using S01 & M01.

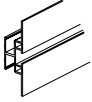

Top Assembly

PART	NO	QTY
	L02B	6
	S01 M6X12	24
	M01 M6	16

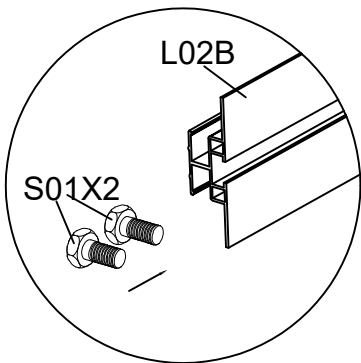
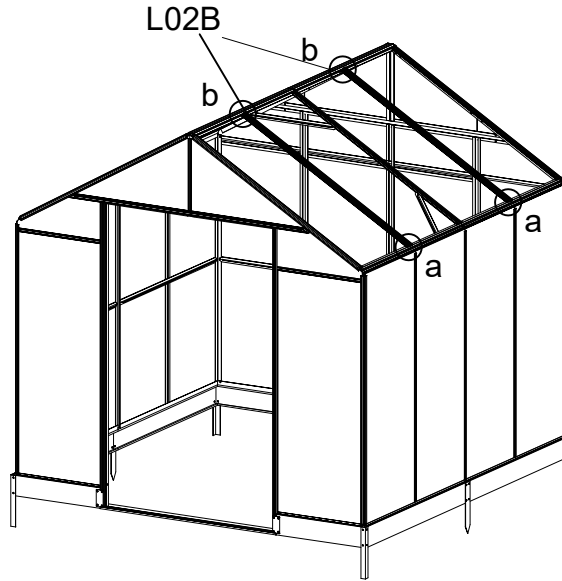



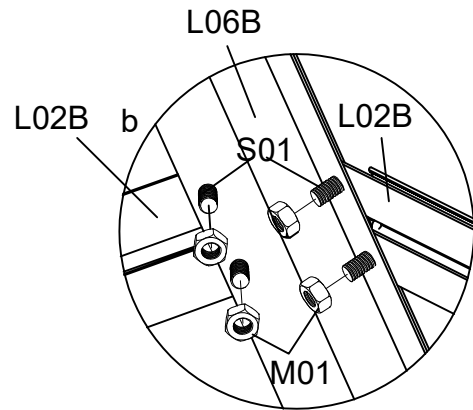
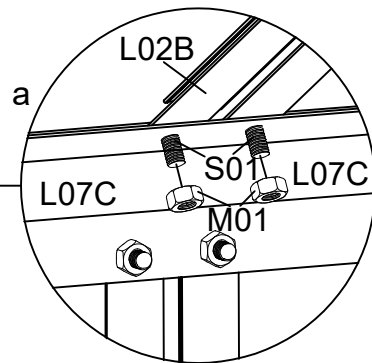

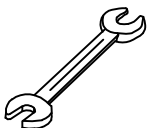

Slide 2 bolts (S01) into each L02B bolt channel to be used later.



Fix glazing bars L02B (8pcs) to the eaves and the ridge profiles with S01 & M01



Top Assembly

PART	NO	QTY
	L23B	4
	L05B	2
	D26	1
	S01 M6X12	8
	M01 M6	20
	Z08 M4.2X16	2

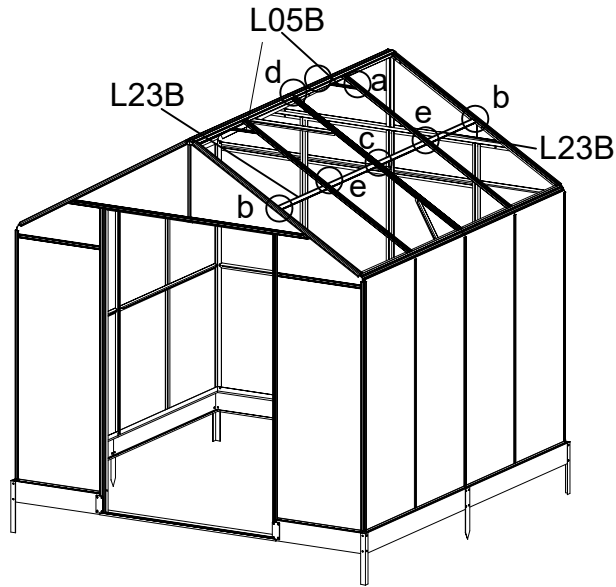

Bolt L05B (d pcs) to L02A & L02B using the S01 bolt placed in the bolt channel earlier.

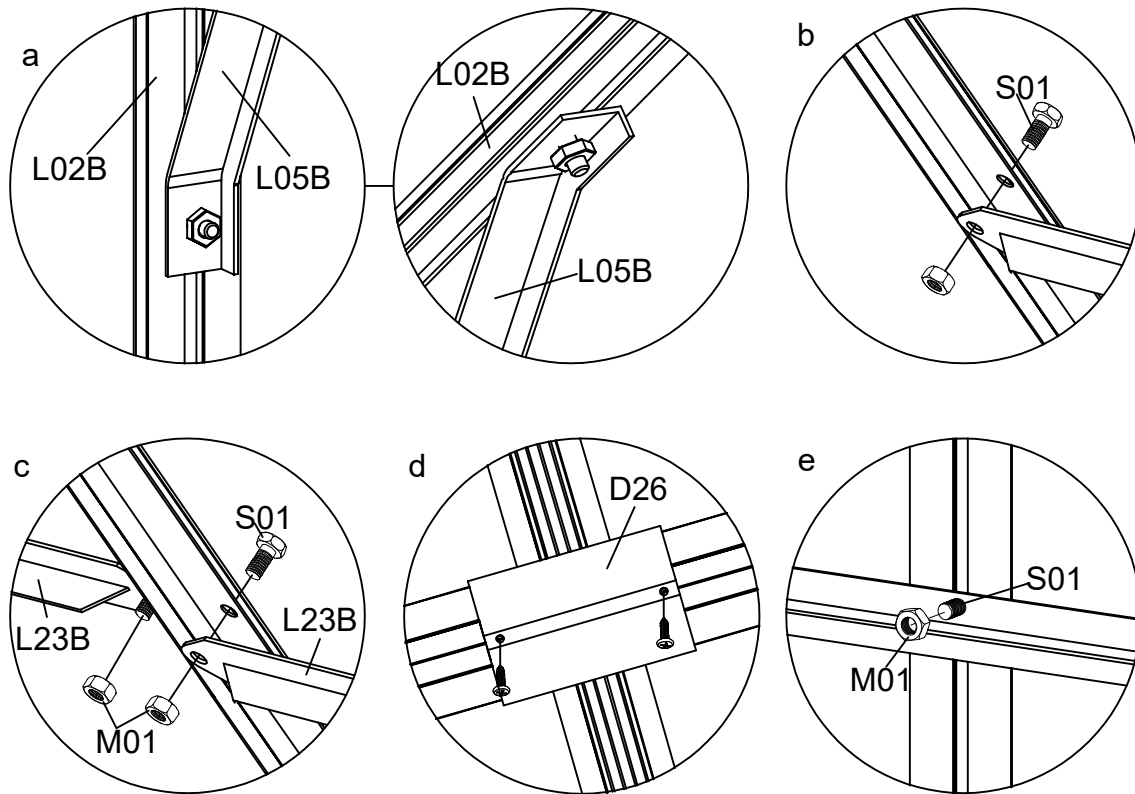







Bolt L23B to L01C/L01D & L03B with S01 & M01.

Fix D26 to L06B from outside with self-tapping screws Z08, using a powered screwdriver.

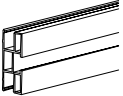
Bolt L23B to L02B using the S01 bolt placed in the bolt channel earlier.



Top Assembly

PART	NO	QTY
	L04A	2
	A03	2
	WINDOW	2
	Y7	6
	Y9	4
	S01 M6X12	12
	M01 M6	12

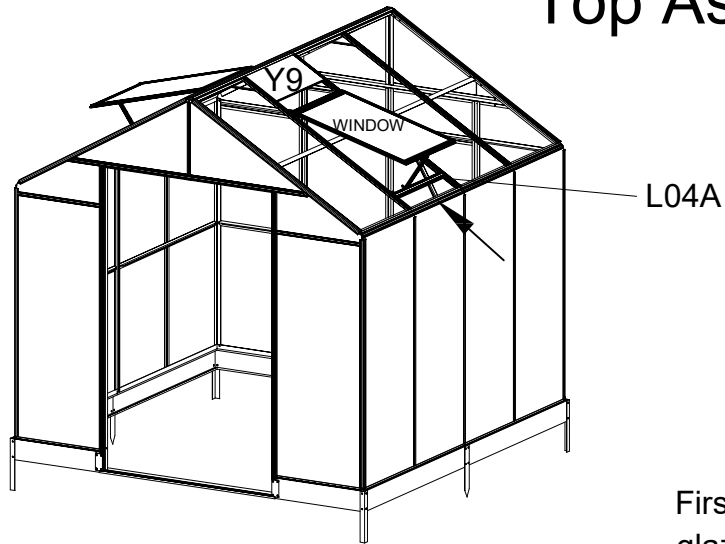

Firstly, slide the glazing panel Y9 into the channel of L02B/L03B

When installing L04A, the window needs to be lifted up to avoid the window not opening after the installation is complete

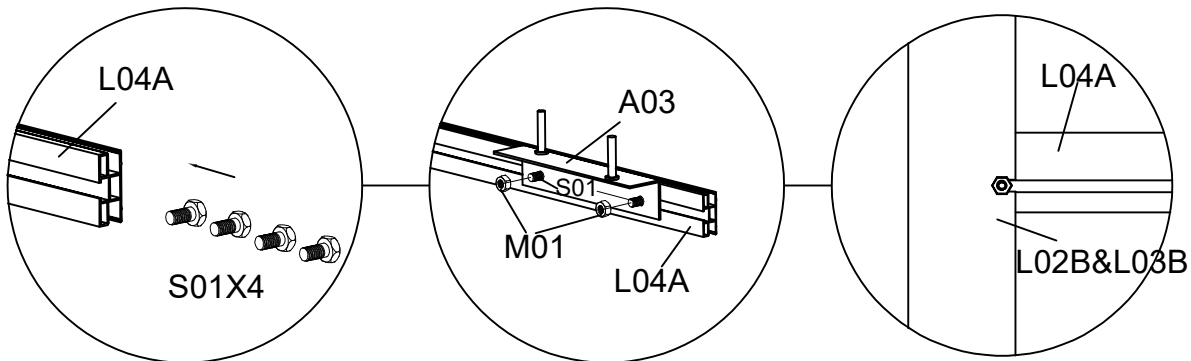

Slide 4 bolts (S01) into each L04A bolt channel. 2 to be fixed with A03, and another 2 to be fixed with L02B/L03B.

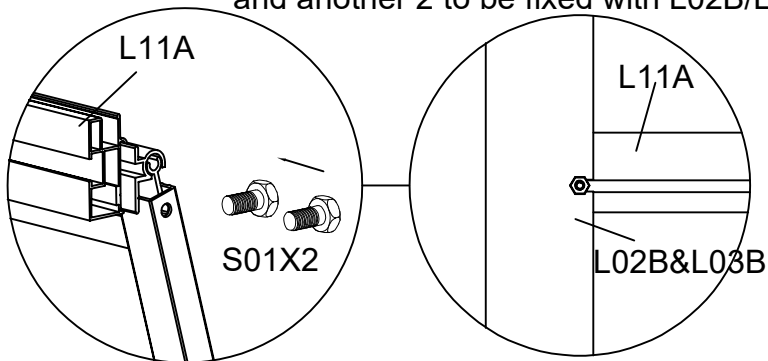



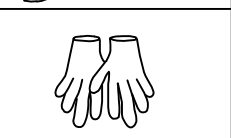
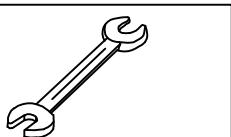
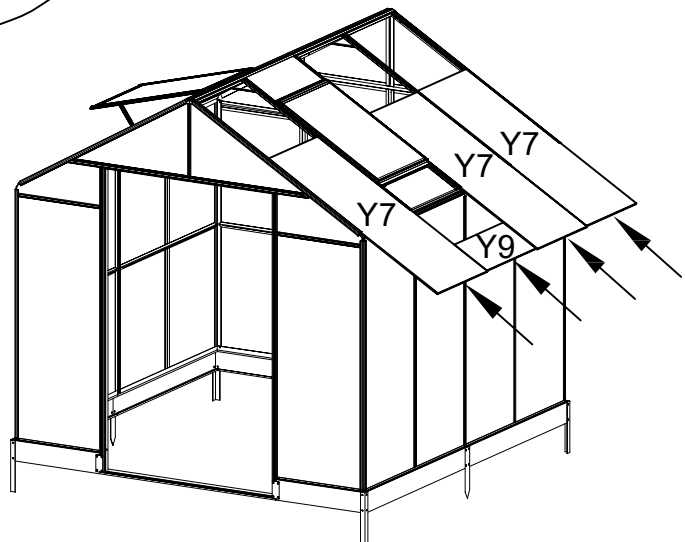

Slide the glazing panels into positions

Slide 2 bolts (S01) into each L11A, and bolt it to L02B/L03B, using the S01 & M01.

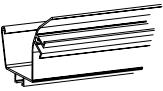

Top Assembly

PART	NO	QTY
	L09B	4
	D25	2
	S01 M6X12	4
	M01 M6	4

After the panels and windows are in position,
put some silicone sealant around to avoid leaking water.

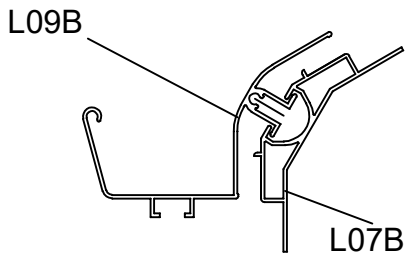
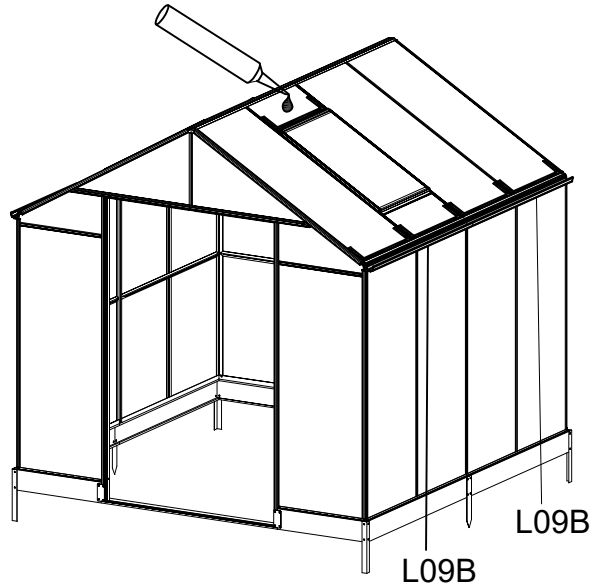



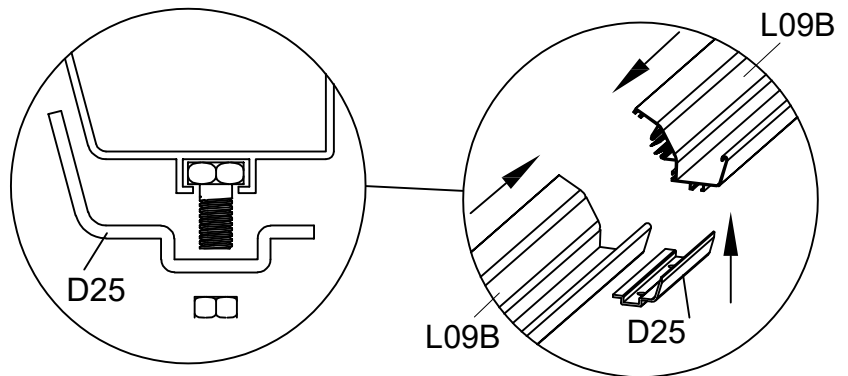

When the panels are completely
inserted, fix gutter profile L09B
Tap it gently into position
with a rubber mallet.

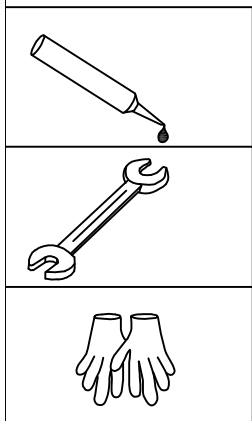

Slide 1*S01 into the bolt channel of both L09B ,
fix D25 to L09B using S01 & M01.



Door Assembly

PART	NO	QTY
	D00R-L	1
	D00R-R	1
	A51	4
	Z17 M4.8X16	8
	S27 M5X12	24

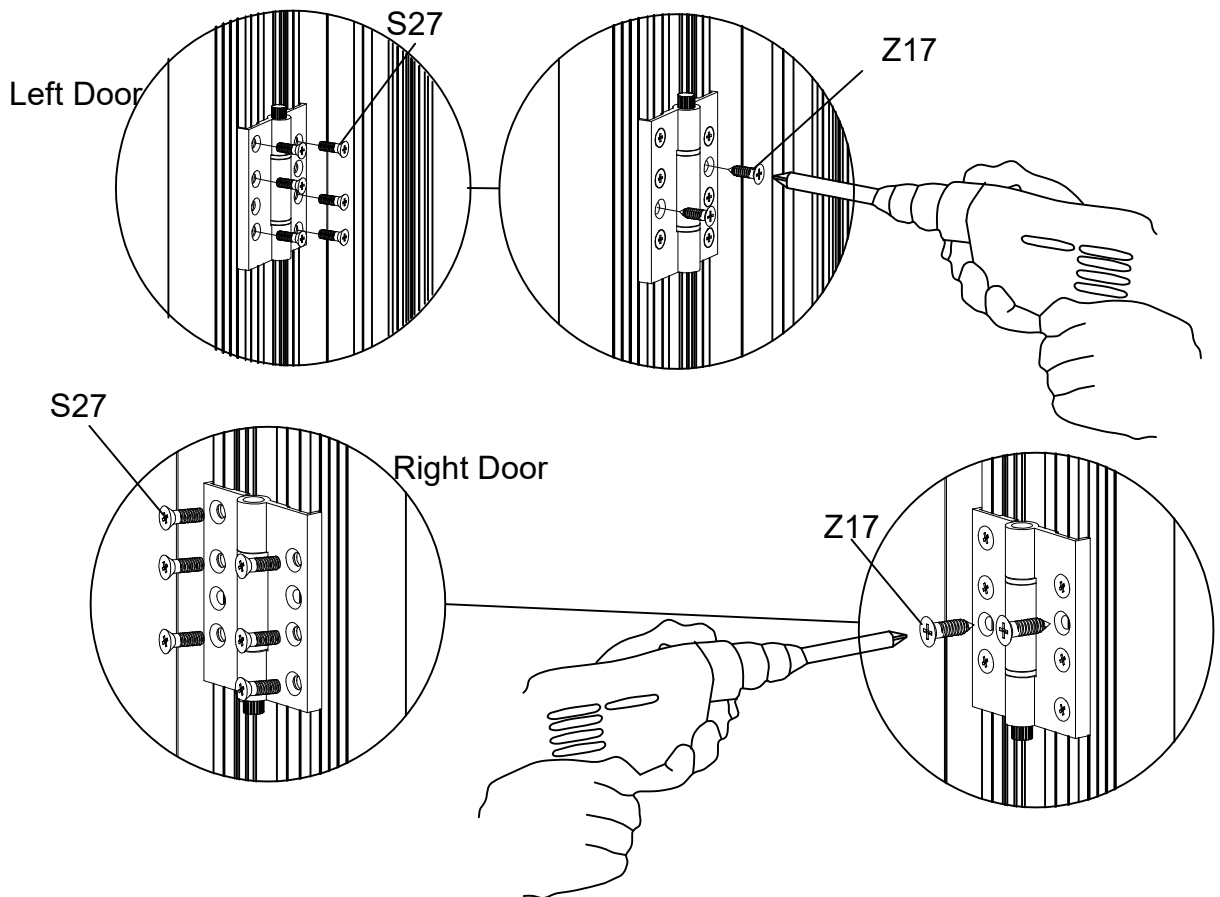
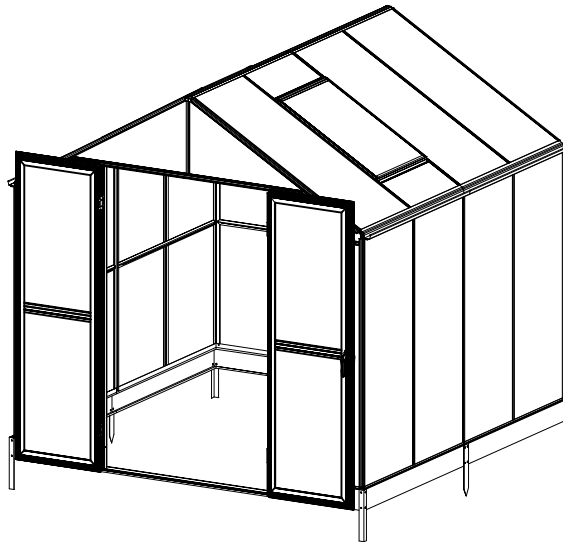

Fix A51(4 PCS) one side on the door profile and the other side to L26A/L26B using S27. Then secure with Z17.

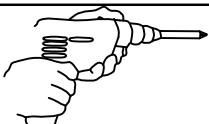

Accessories Assembly

PART	NO	QTY
	J55	2
	J56R	2
	J56L	2
	J94	4
	L25	4
	J93	4
	J166	4
	Z08	4
	Z02	
	Ø4X16D	8

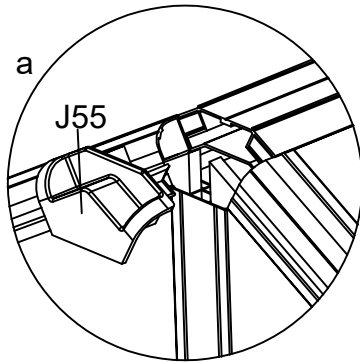
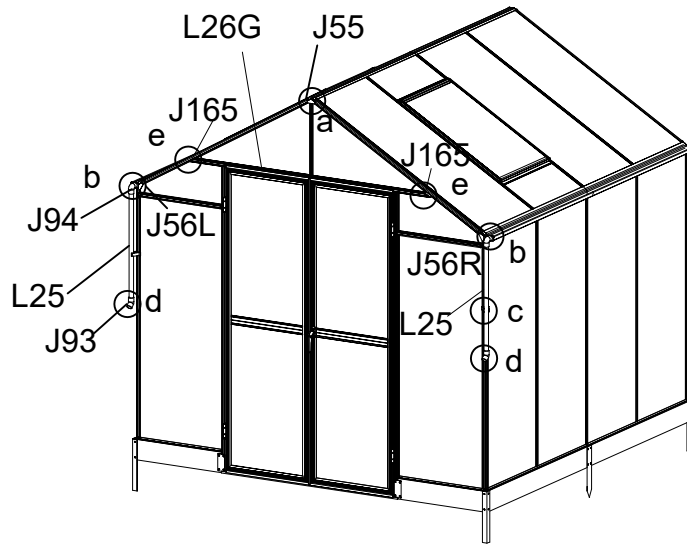

Fix the cover caps J55 into the ridge profile

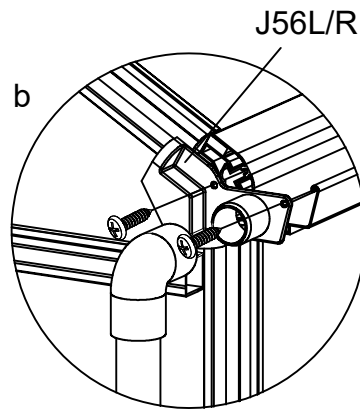

Fix the cover caps (J56L/R) carefully with Z02. Be careful to ensure that the screws are driven in straight and in the correct position (see detail drawings).

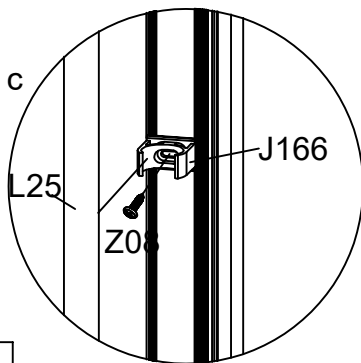

Drill a hole in L01A/L01B, approximately 3mm diameter and 400mm down from the gutter. Fix the J166 downpipe bracket with Z08 screws and then clip the L25 downpipe into the J166 bracket.

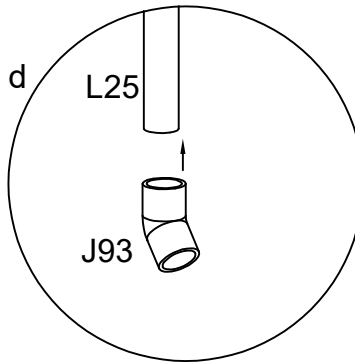

If you wish to eliminate leaks, use glue when fixing the downpipe bends (not provided).

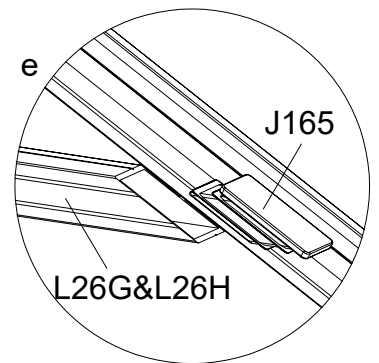

Cover both ends of L26G with cap J165

