





CHLOE 6 DOOR 2 DRAWER MIRRORED WHITE WARDROBE

INSTALLATION AND ASSEMBLY GUIDE

A LIST OF MATERIALS

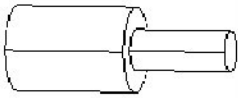
A	B	C	D	E	G
					

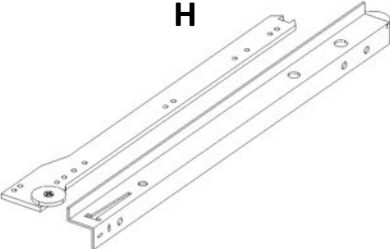
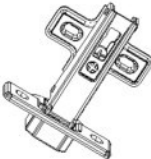
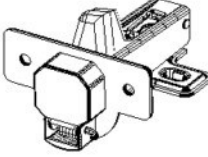
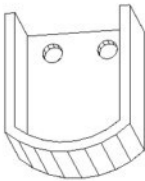
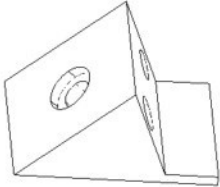
H	I	J	K	L
				

PIECES	QUANTITY
A:MINIFIX BODY	40
B:MINIFIX SCREW	40
C:DOWEL	40
D:SHELF PIN	12
E:3,5*17 SCREW	112
G:3,5*30 SCREW	7

PIECES	QUANTITY
H:RAIL SET	2 SET
I:FLAT HINGE	6
J:HUMP HINGE	10
K:HANGER FLANGE	6
L:BACKREST FIXER	12
HANGER PIPE	3

NOTE : PLEASE HAVE AT LEAST ONE PERSON ASSISTING DURING THE ASSEMBLY.

CHLOE 6 DOOR 2 DRAWER MIRRORED WHITE WARDROBE

-Before starting the assembly, take all the parts out of the box and check them according to the assembly manual.

Before starting the assembly, clean each part with a damp cloth.

-Although the products are carefully checked and packaged, if you encounter a problem during shipping, you can check the necessary parts contact us at the contact numbers on our website. The problem will be fixed as soon as possible free of charge.

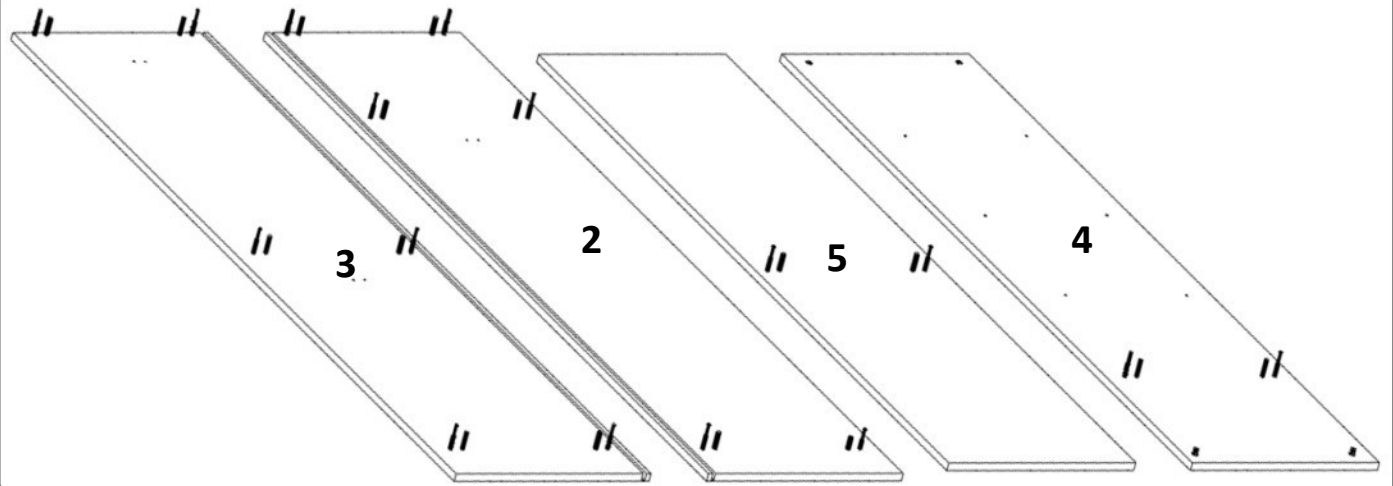

1	2	3	4	5	6	7	8
BOTTOM TABLE	RIGHT SIDE	LEFT SIDE	RIGHT MIDDLE SIDE	LEFT MIDDLE SIDE	FIXED SHELF	UPPER TABLE	FIXED SHELF
1 PIECE	1 PIECE	1 PIECE	1 PIECE	1 PIECE	1 PIECE	1 PIECE	2 PIECE
B							
BASE							
2 PIECE							

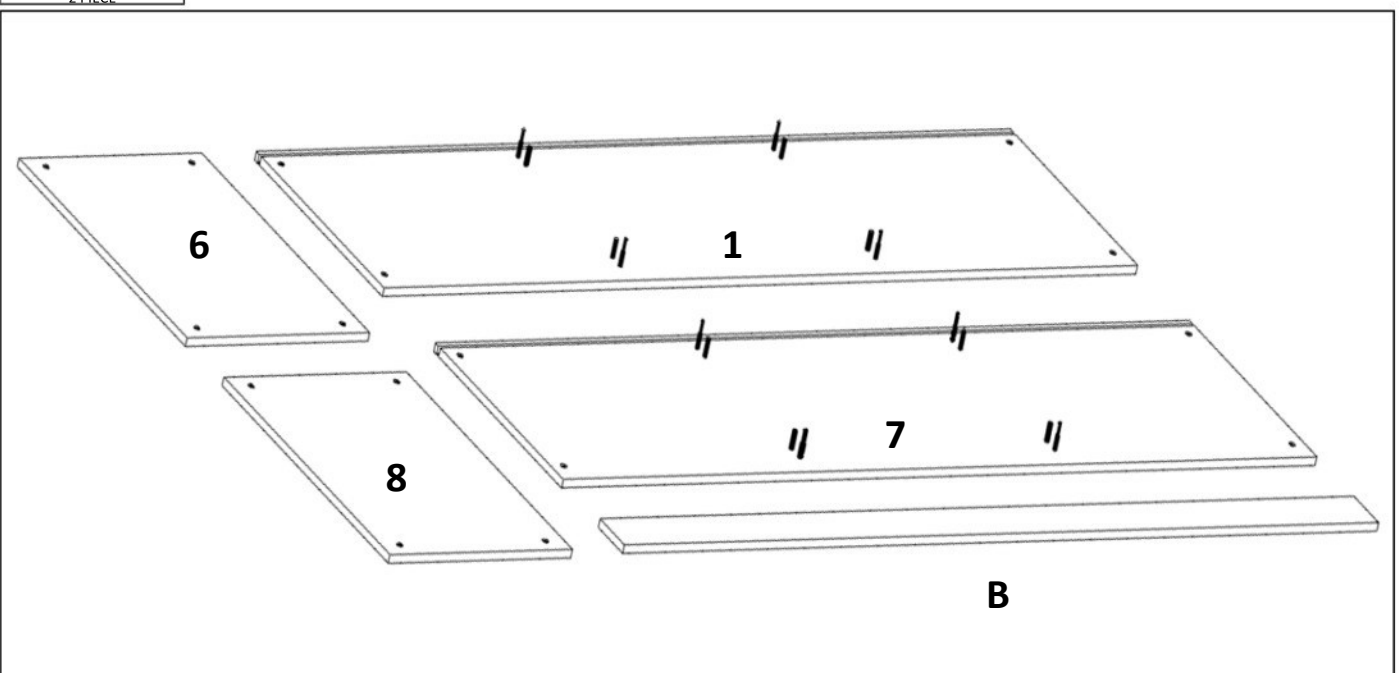

NOTE : PLEASE HAVE AT LEAST ONE PERSON ASSISTING DURING THE ASSEMBLY.

PIECES DIMENSIONS

180 CM CABINET

SIZE	WIDTH	QUANTITY	EXPLANATION
1800	520	1	RIGHT SIDE (2)
1800	520	1	LEFT SIDE (3)
2068	520	1	BOTTOM TABLE(1)
2068	520	1	UPPER TABLE(7)
1668	500	1	RIGHT MIDDLE SIDE 4)
1668	500	1	LEFT MIDDLE SIDE (5)
684	500	1	FIXED SHELF(6)
684	480	3	MOVING SHELF
676	500	2	FIXED SHELF (8)
2068	100	2	BASE (B)
627	100	2	DRAWER SPACER
400	100	4	DRAWER LEFT AND RIGHT SIDE

210 CM CABINET

SIZE	WIDTH	QUANTITY	EXPLANATION
2075	520	1	RIGHT SIDE (2)
2075	520	1	LEFT SIDE (3)
2068	520	1	BOTTOM TABLE(1)
2068	520	1	UPPER TABLE(7)
1943	500	1	RIGHT MIDDLE SIDE 4)
1943	500	1	LEFT MIDDLE SIDE (5)
684	500	1	FIXED SHELF(6)
684	480	3	MOVING SHELF
676	500	2	FIXED SHELF (8)
2068	100	2	BASE (B)
627	100	2	DRAWER SPACER
400	100	4	DRAWER LEFT AND RIGHT SIDE

DOORS

SIZE	WIDTH	QUANTITY	EXPLANATION
1698	347	2	RIGHT COVER
1698	347	2	LEFT COVER
1344	347	1	RIGHT MIDDLE DOOR
1344	347	1	LEFT MIDDLE DOOR
698	174	2	DRAWER

DOORS

SIZE	WIDTH	QUANTITY	EXPLANATION
1973	347	2	RIGHT DOOR
1973	347	2	LEFT DOOR
1619	347	1	RIGHT MIDDLE DOOR
1619	347	1	LEFT MIDDLE DOOR
698	174	2	DRAWER

BACKREST

SIZE	WIDTH	QUANTITY	EXPLANATION
1682	520	4	CABINET BODY BACKREST
641	400	2	DRAWER BACKREST

BACKREST

SIZE	WIDTH	QUANTITY	EXPLANATION
1957	520	4	CABINET BODY BACKREST
641	400	2	DRAWER BACKREST

NOTE : PLEASE HAVE AT LEAST ONE PERSON ASSISTING DURING THE ASSEMBLY.

Start the wardrobe installation by fixing the BASES as shown in Figure 1. Fix the bases parts with 3.5*50 screws with the help of a cordless drill.

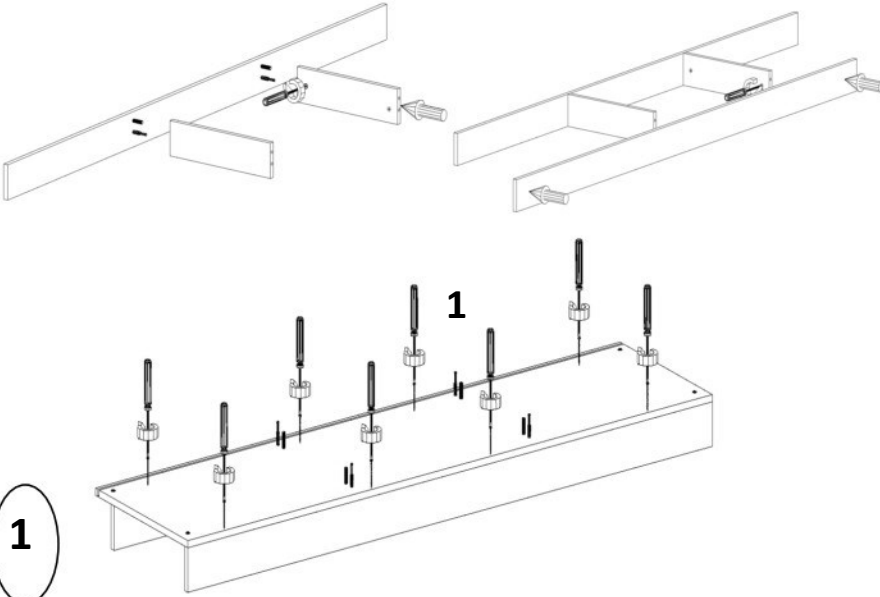

After creating the bottom table with the bases, place the right side and fixed shelf on the minifix screws and dowels as in figure 2. and tighten minifix screws. As the 2nd step, fix the right middle fixig and finally the fixed shelf as in figure 3.

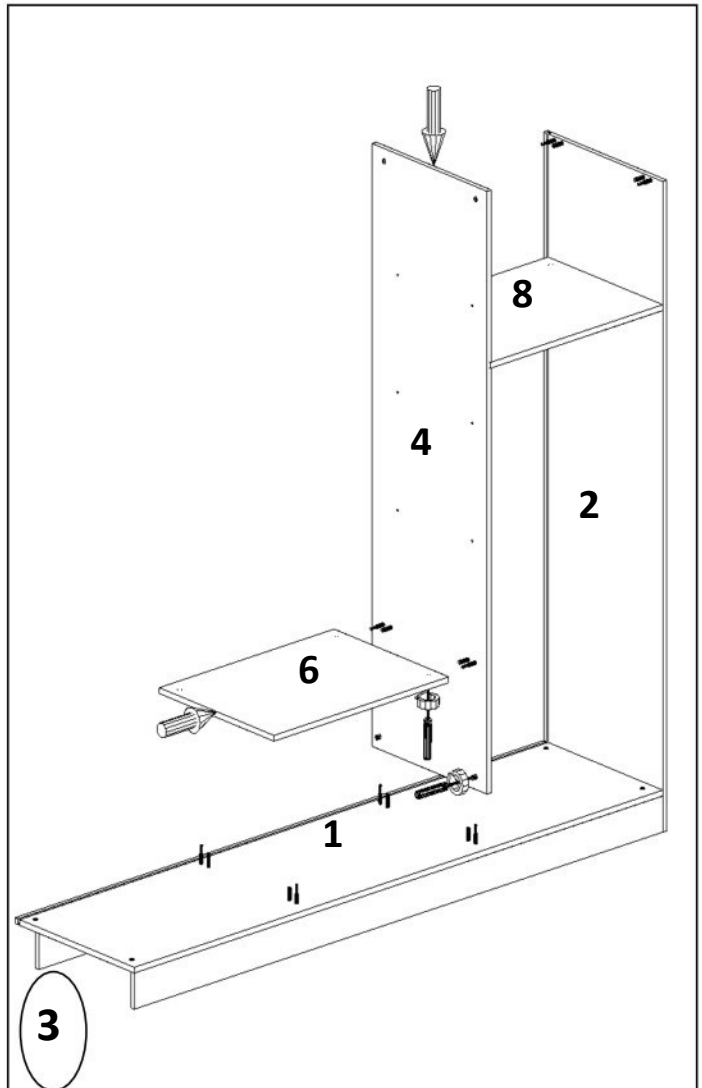
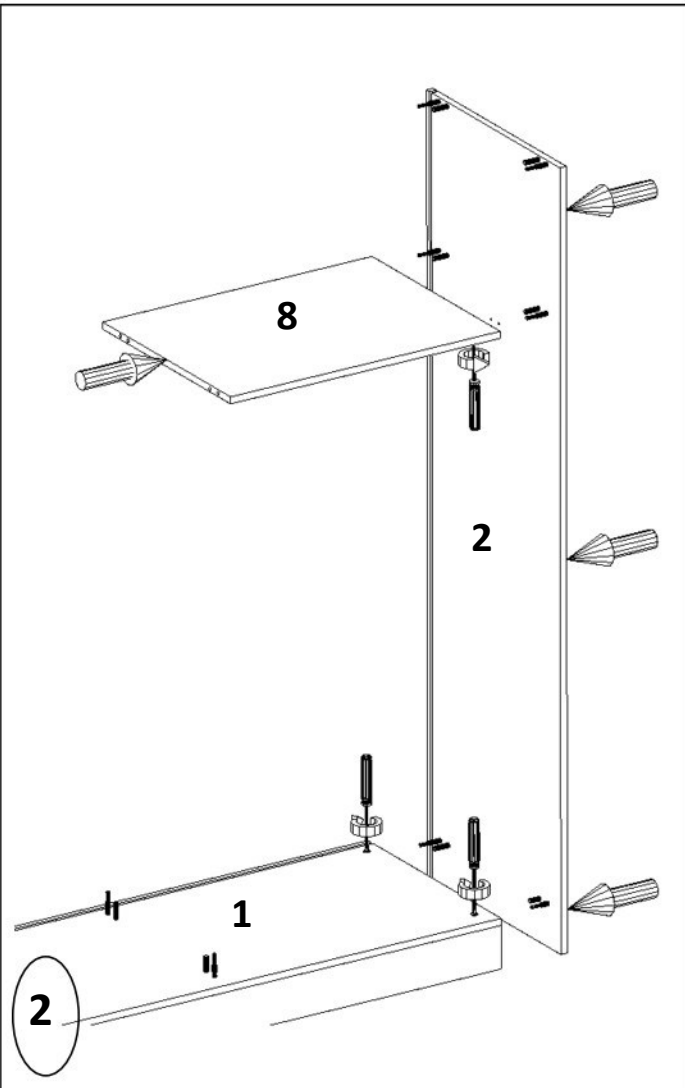

NOTE : PLEASE HAVE AT LEAST ONE PERSON ASSISTING DURING THE ASSEMBLY.

Place the left middle fixing of the wardrobe and fixed shelf on the on the minifix screws and dowels and tighten the minifix screws as shown in figure 4. Then place the left side on the minifix screws and dowels and fix it. Insert the back rests of the gardrobe into the channel as in Figure 5.

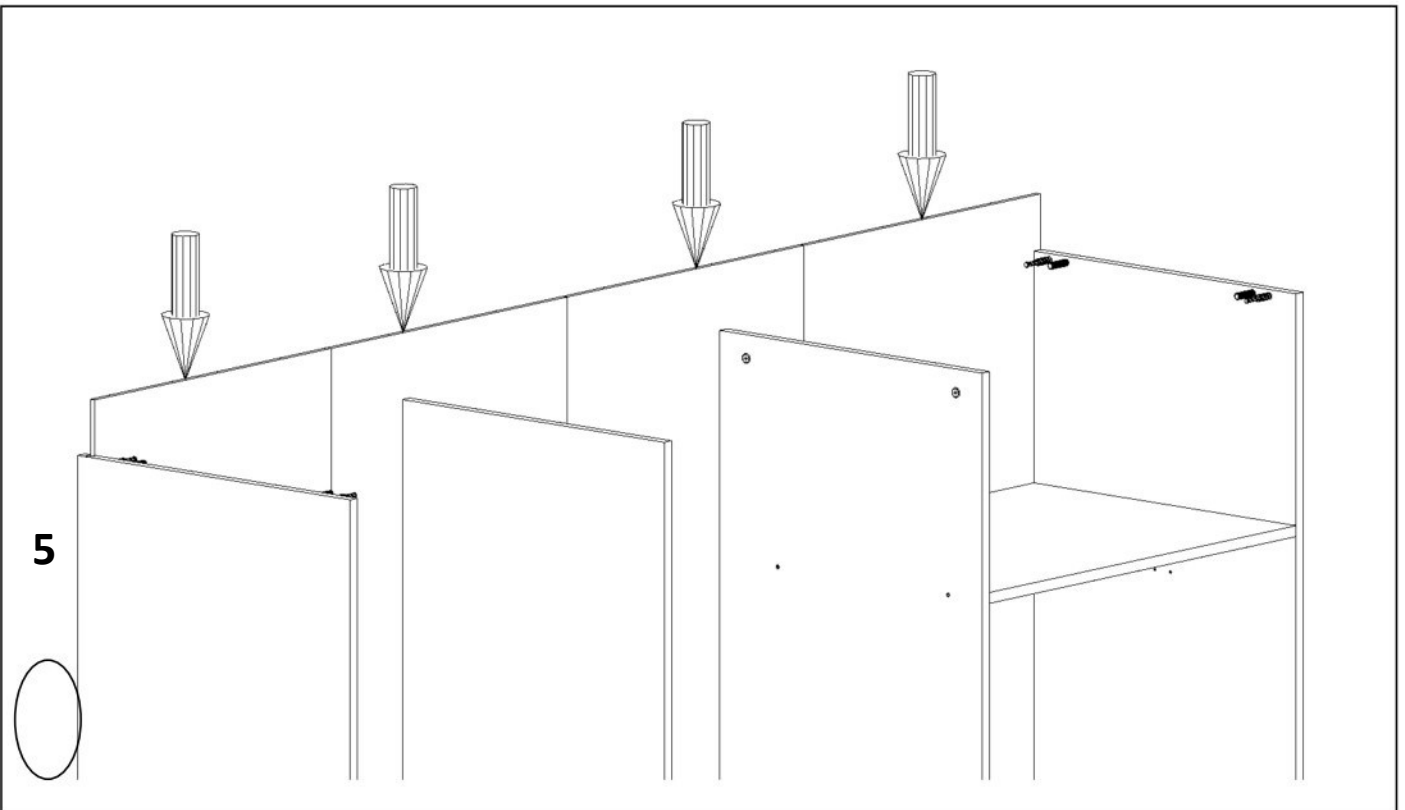
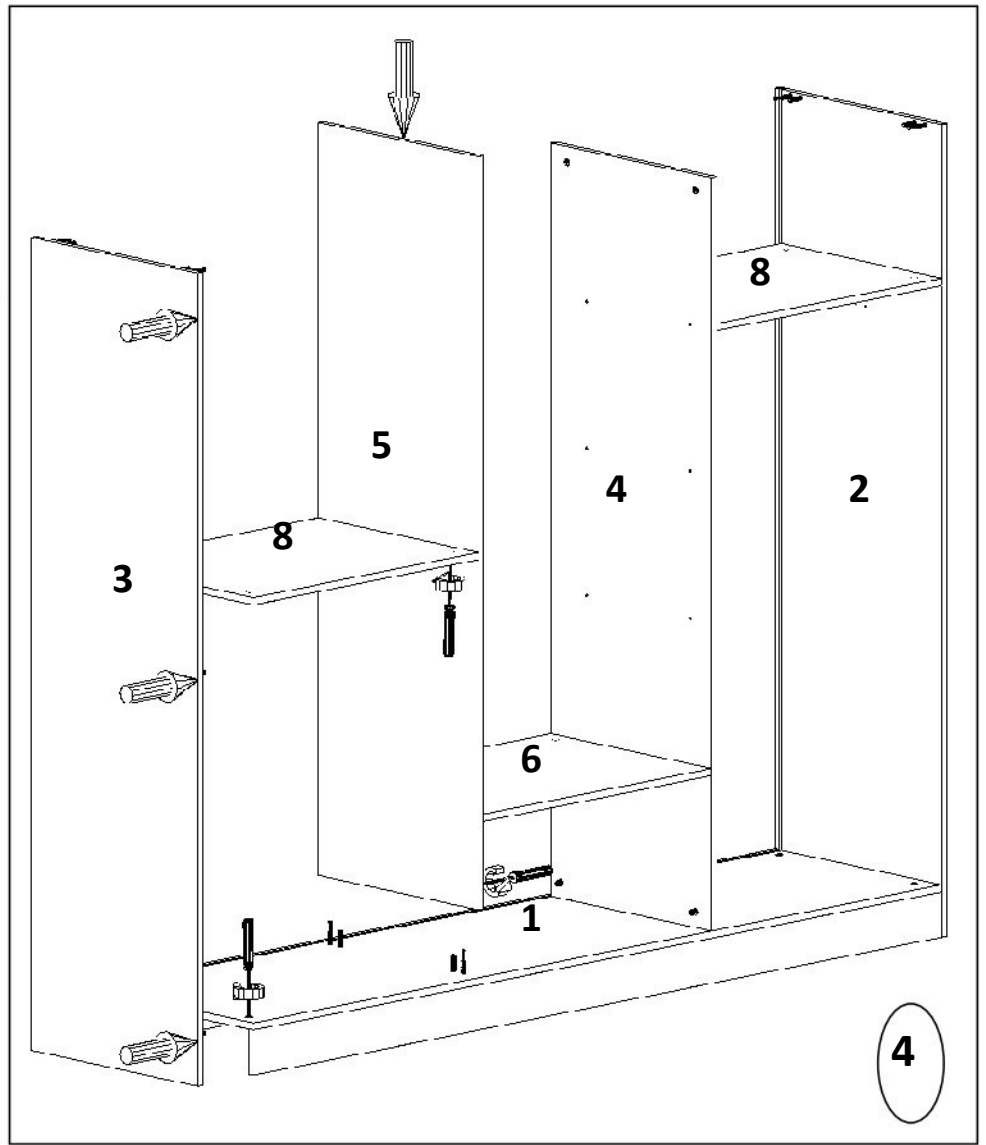

NOTE : PLEASE HAVE AT LEAST ONE PERSON ASSISTING DURING THE ASSEMBLY.

Place and fix the upper table of the wardrobe as in figure 5. Fix the hanger pipe flanges with 3.5x17 screws from the designated holes.

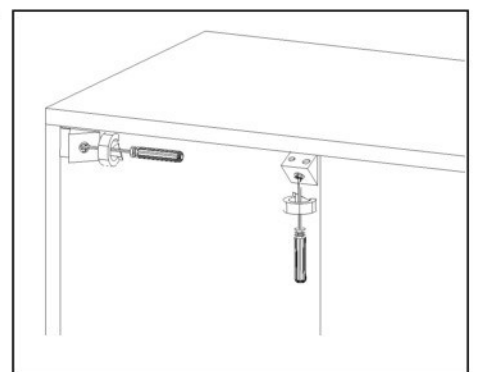
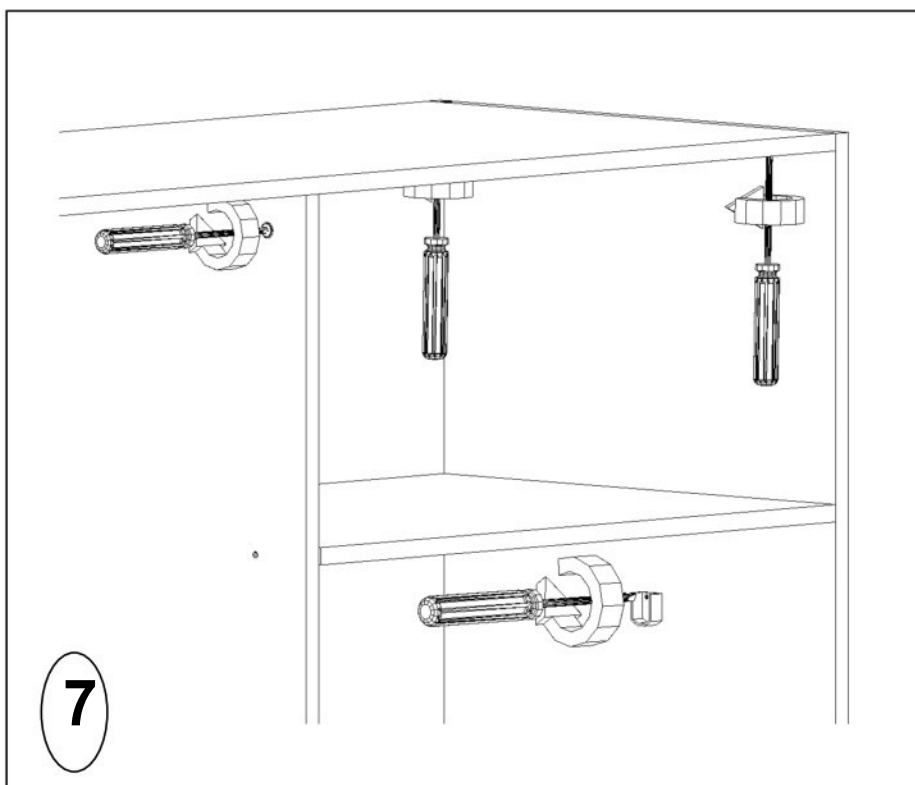
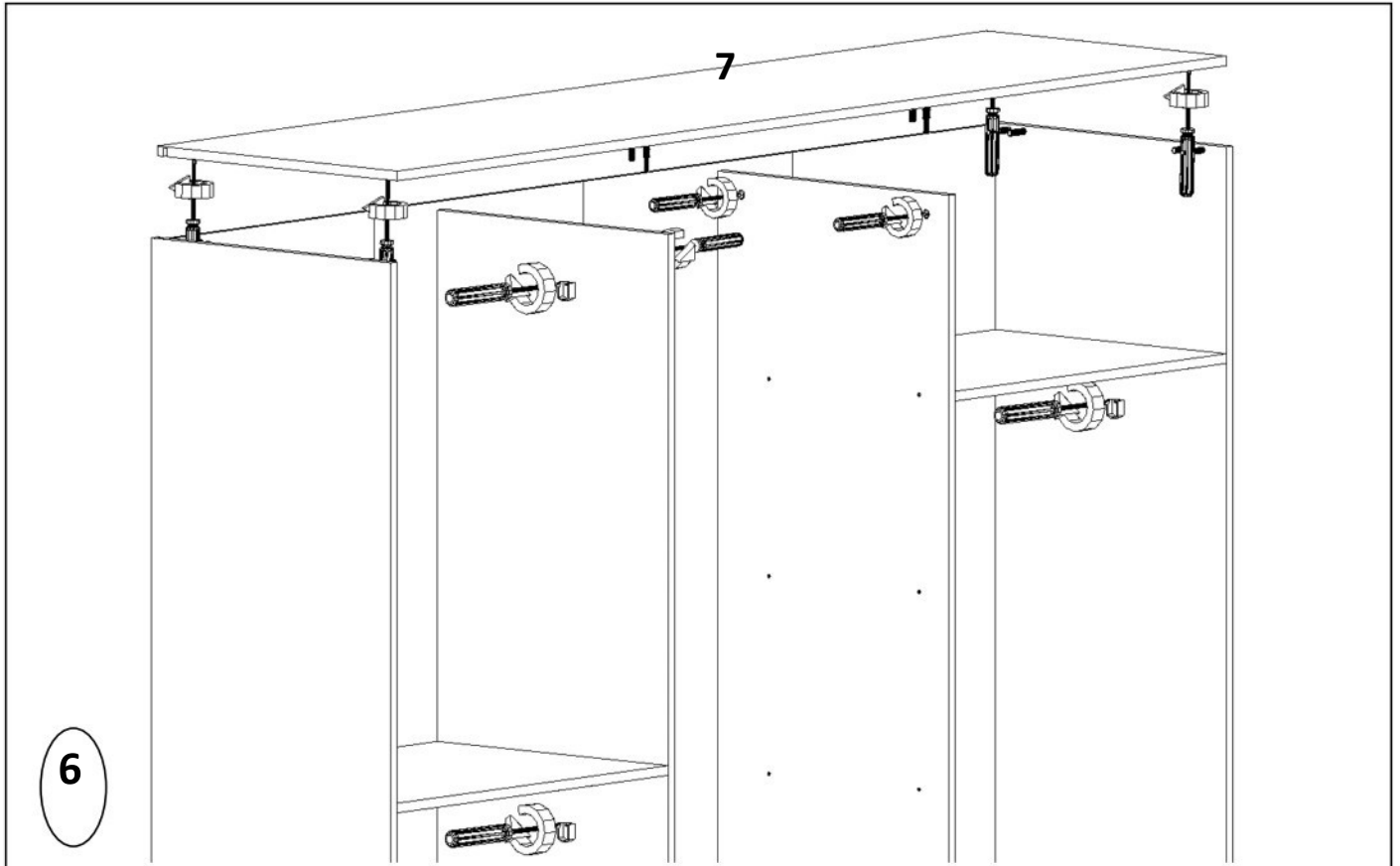

The body of the wardrobe is completed. After this process, fix the backrest fixers with 3.5x17 screws.

NOTE : PLEASE HAVE AT LEAST ONE PERSON ASSISTING DURING THE ASSEMBLY.

Insert the shelf pins of the wardrobe and place the movable shelves.

Attach the wardrobe door as in figure 9. and fix it through the determined screw holes. There are two types of hinge groups. Attach (curved) hump hinges to the middle doors.. After the door process, install the handle screws and fix the handles.

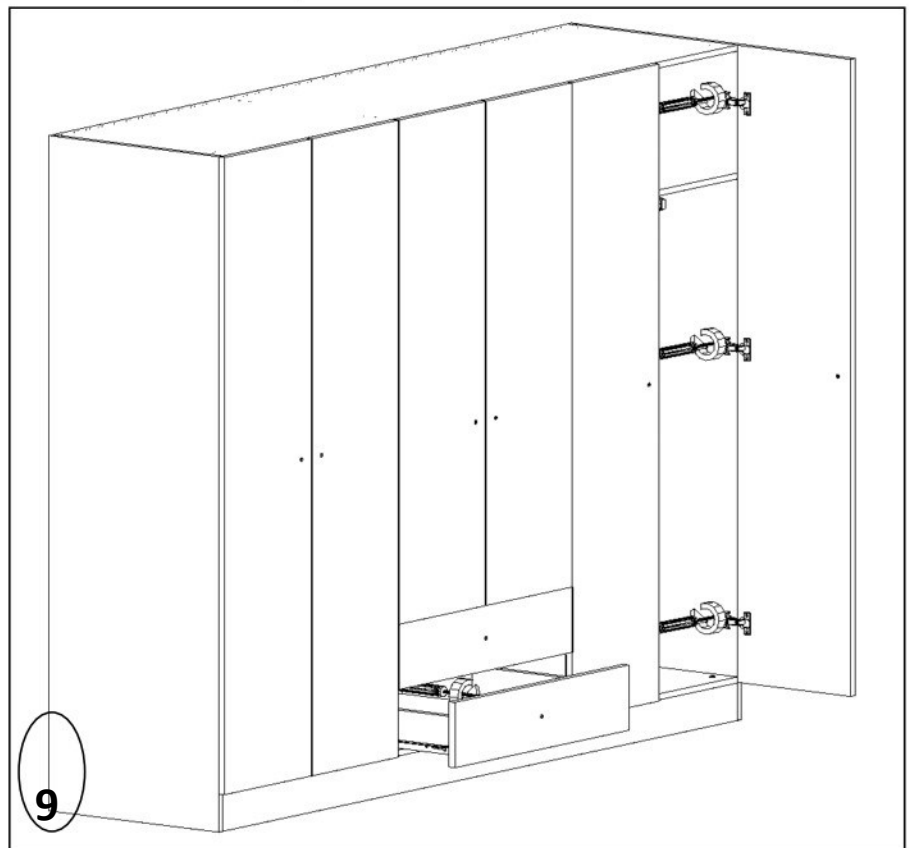
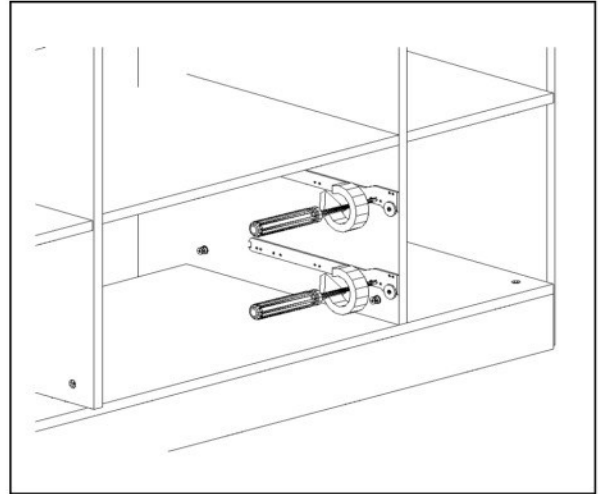
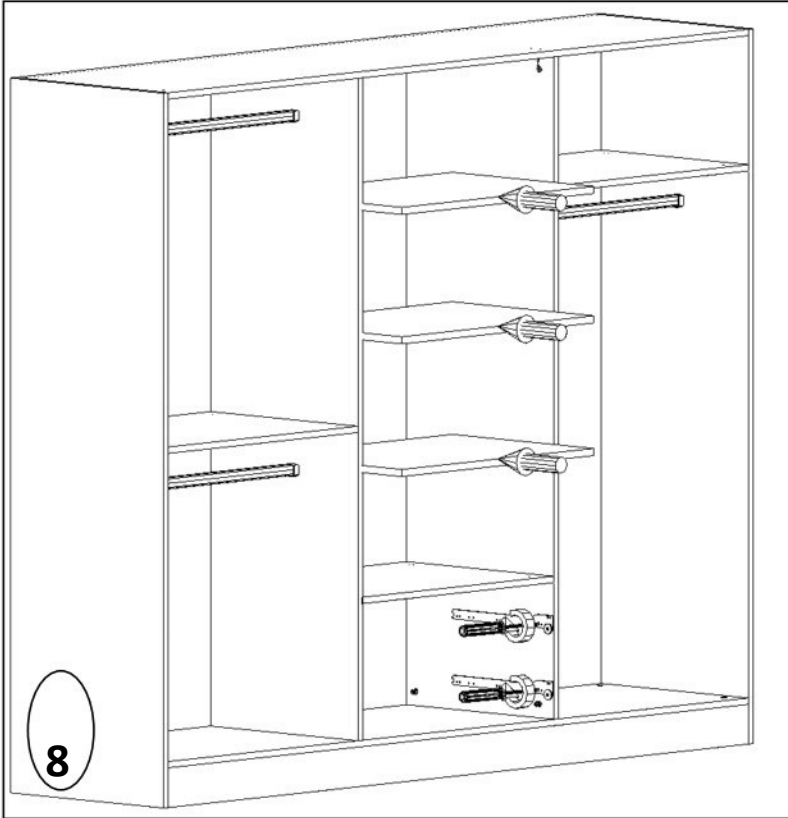

NOTE : PLEASE HAVE AT LEAST ONE PERSON ASSISTING DURING THE ASSEMBLY.

Start the assembly of the crown accessories on the top of the wardrobe from the left crown part first. Place on the same line the crown part back and the back of the wardrobe as shown in Figure 10. and fix the crown part with a 3.5x30 screw with the help of a cordless drill. Then fix the long crown part from the inside of th wardrobe at the corner points. Repeat the same process for the last piece of the crown.

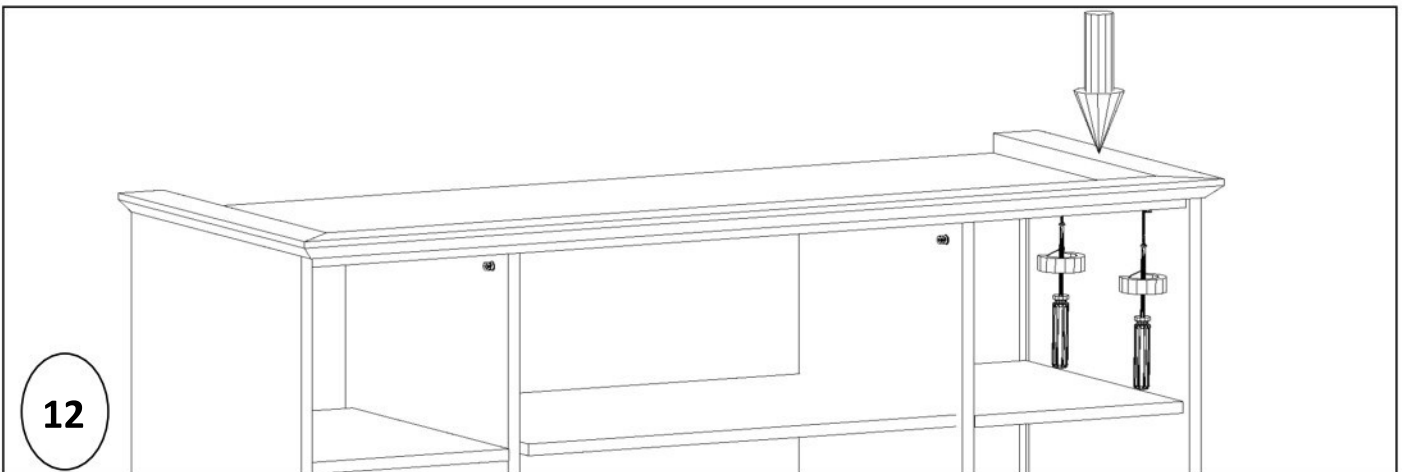
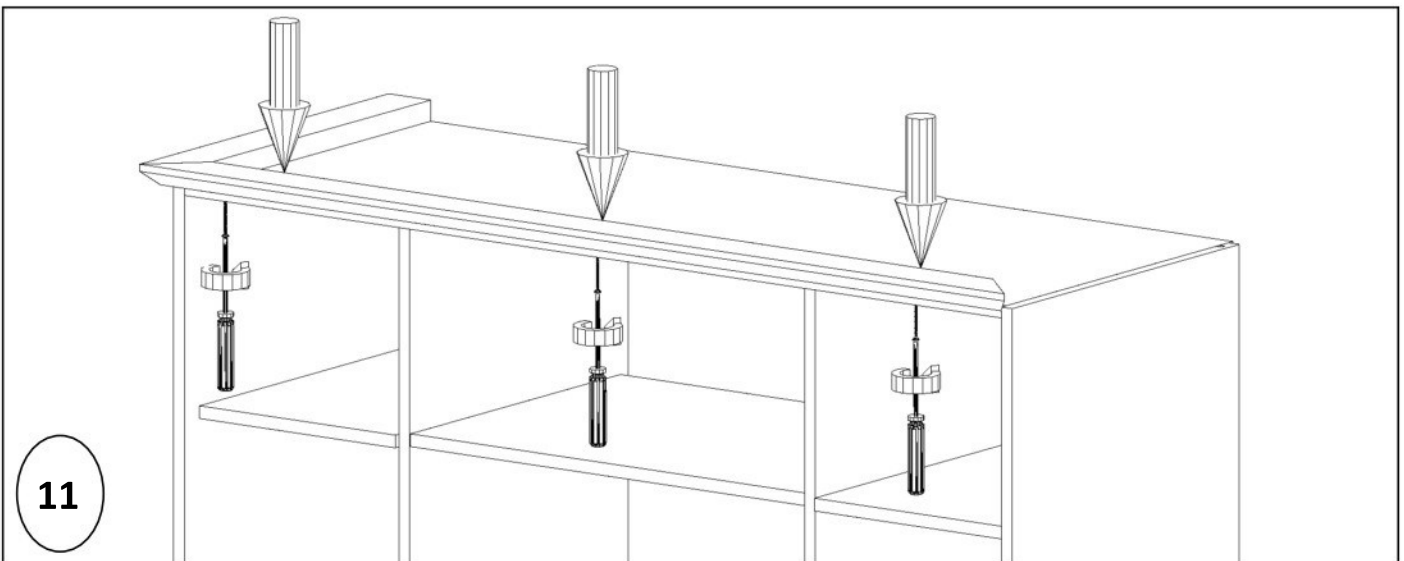
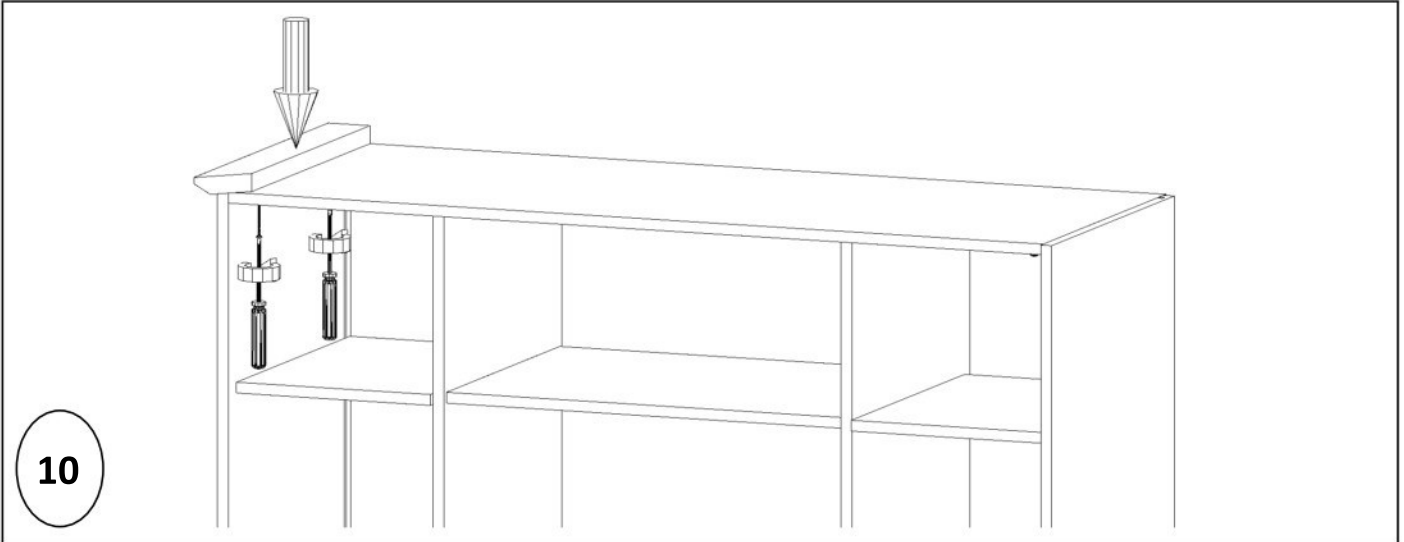

NOTE : PLEASE HAVE AT LEAST ONE PERSON ASSISTING DURING THE ASSEMBLY.

(THE CROWN ACCESSORIES SHOWN FOR INSTALLATION IN THE IMAGES IS NOT INCLUDED IN OUR GOLD GROUP PRODUCTS THAT WE MANUFACTURED .)

DRAWER CASE INSTALLATION

Before starting the drawer case installation , place the furniture materials as in figure 1. Place the chipboard panels on the minifix screws and dowels as in figure 2 and fix the minifix screws.

Insert the backrest into the channel. Then place the cover of the drawer on the minifix shaft and dowels as in figure 4 and fix the minifix screws. And fix the drawer rail with 3.5x17 screw as in the figure 5.

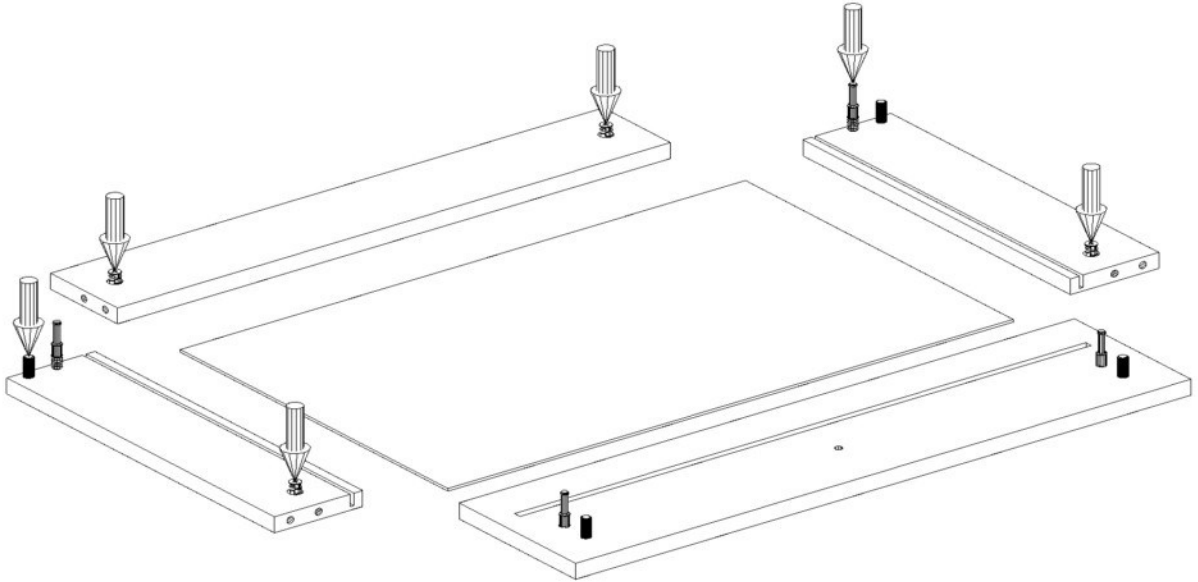
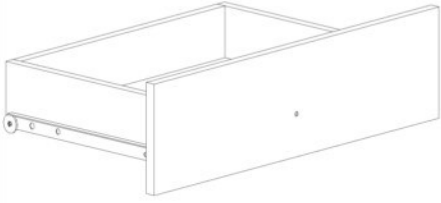

1

2

4

5

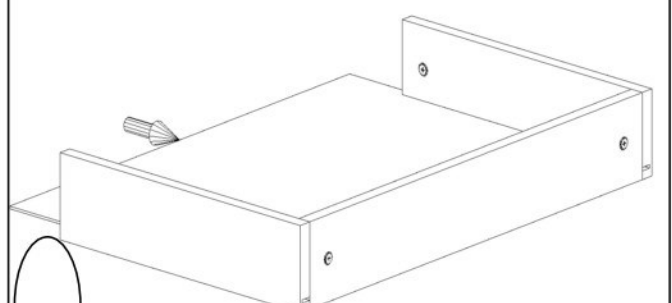
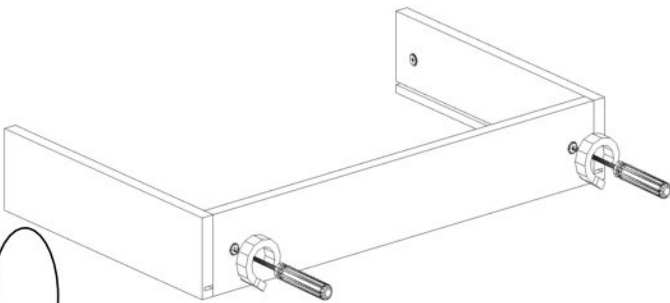

3

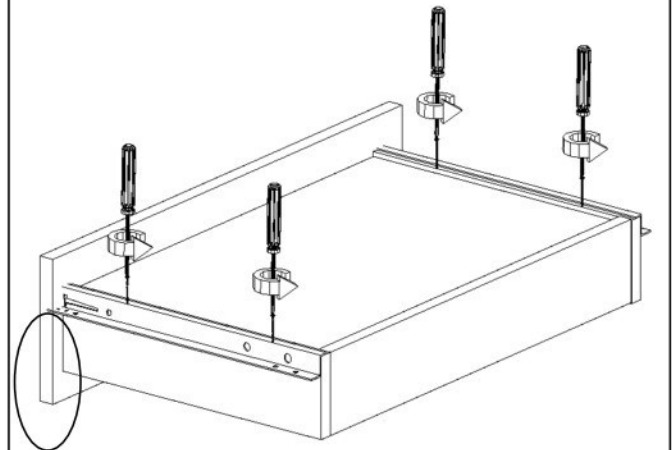

NOTE : PLEASE HAVE AT LEAST ONE PERSON ASSISTING DURING THE ASSEMBLY.