

## NOTICE













- \* Please make sure that you have all parts indicated and they are in good condition before you begin assembly of this item. Refer to part list and hardware list below for guidance.
- \* This item should be assembled on a soft surface to prevent scratching the finish during assembly.
- \* This item may require periodic tightening.
- \* If you are having difficulty, our friendly Customer Care team is always here to help.

## PREPARATION

- \* Before beginning assembly of product, make sure all parts are present. Compare parts with part contents list and hardware contents list.
- \* If any part is missing or damaged, do not attempt to assemble the product.
- \* Estimated Assembly Time: 15 minutes.
- \* Tools Required for Assembly (included): Allen Key & Phillips Screw Driver

## CARE AND MAINTENANCE

- \* Always use felt pads under all articles to prevent discoloration or softening of the lacquer. Plastic and rubber bases on items can discolor wood. Wipe up spills immediately and avoid common hazards such as hot dishes, harsh solvents and abrasives. Cleaning should be done with a soft lint free cotton cloth dampened with water or furniture polish. On highly used surfaces we recommend applying a quality paste wax which should be used on a regular basis to provide additional protection from scratches and spills. How often you apply the wax depends on how much wear the furniture receives.

Part List and Hardware List			
PIECE	DESCRIPTION	PICTURE	QUANTITY
A	Side plate( left)		1X
B	Side plate( right)		1X
C	Front plate		1X
D	Back plate		1X
E	Top plate		1X
F	Bottom plate		1X
HW1	Hex socket screws (M3 x 1 x 25MM)		12X
HW2	Phillips screws (M3 x 1 x 12MM)		6X
HW3	Phillips screws (M3 x 1 x 10MM)		4X
HW4	Support Rod		1X
HW5	Phillips Screw Driver		1X
HW6	Allen key		1X

Product Dimensions: 19.41"W X 12.01"D X 24.10"H

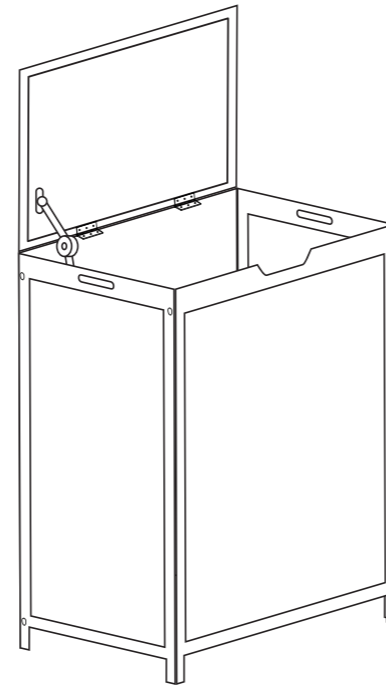

### ⚠ WARNING ⚠

Weight Capacity - 30 LBS

Warning: Do not stand on product

Warning: Do not over torque bolts.

## PREPARATION

- \* Before beginning assembly of product, make sure all parts are present. Compare parts with part contents list and hardware contents list.
- \* If any part is missing or damaged, do not attempt to assemble the product.
- \* Estimated Assembly Time: 15 minutes.
- \* Tools Required for Assembly (included): Allen Key & Phillips Screw Driver
- \* If you are having difficulty, our friendly Customer Care team is always here to help.

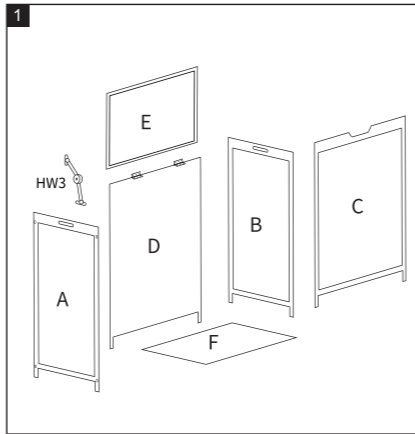
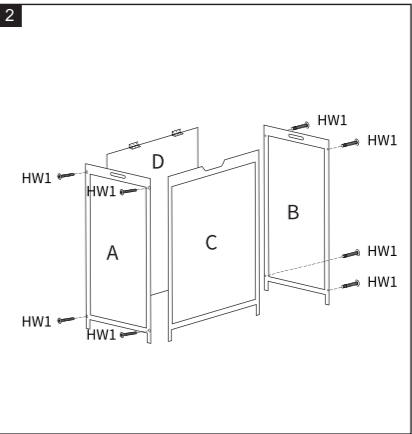
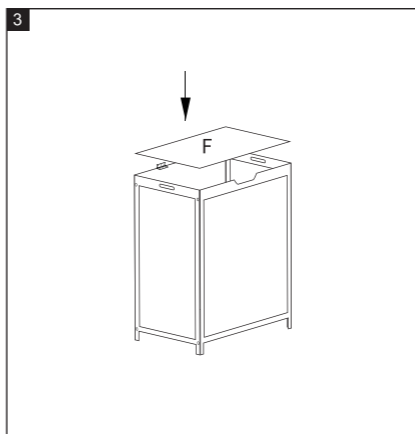
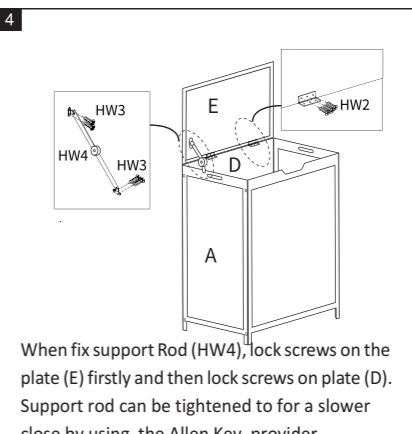
	
<p><b>Step1:</b> Find the corresponding parts as the picture showed</p>	<p><b>Step2:</b> Fix side plate (A) &amp; (B) to the front plate (C) &amp; back plate(D) using (HW1)Hex socket screws</p>
	 <p>When fix support Rod (HW4), lock screws on the plate (E) firstly and then lock screws on plate (D). Support rod can be tightened to for a slower close by using the Allen Key provider.</p>
<p><b>Step3:</b> Put plate (F) to the bottom</p>	<p><b>Step4:</b> Fix plate (E) to plate(D) using (HW2) phillips screws and then add (HW4) Support Rod between plate (A) and plate (E) using (HW3) phillips screws</p>